

12-2013

# Elementary Differential Equations with Boundary Value Problems

William F. Trench

*Trinity University*, wtrench@trinity.edu

Follow this and additional works at: [http://scholarcommons.usf.edu/oa\\_textbooks](http://scholarcommons.usf.edu/oa_textbooks)

 Part of the [Mathematics Commons](#), and the [Ordinary Differential Equations and Applied Dynamics Commons](#)

---

## Recommended Citation

Trench, William F, "Elementary Differential Equations with Boundary Value Problems" (2013). *Textbooks Collection*. Book 8.  
[http://scholarcommons.usf.edu/oa\\_textbooks/8](http://scholarcommons.usf.edu/oa_textbooks/8)

This Book is brought to you for free and open access by the USF Tampa Library Open Access Collections at Scholar Commons. It has been accepted for inclusion in Textbooks Collection by an authorized administrator of Scholar Commons. For more information, please contact [scholarcommons@usf.edu](mailto:scholarcommons@usf.edu).

# ELEMENTARY DIFFERENTIAL EQUATIONS WITH BOUNDARY VALUE PROBLEMS

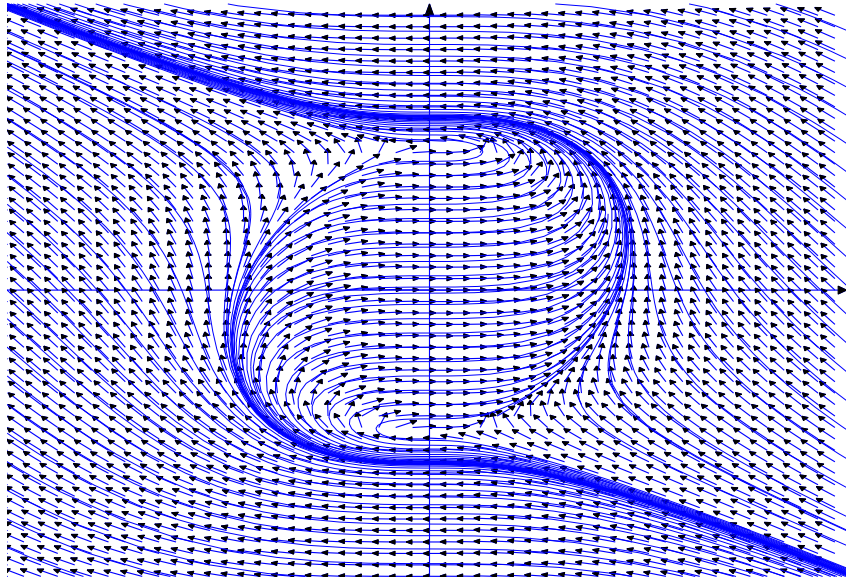

**William F. Trench**

Andrew G. Cowles Distinguished Professor Emeritus  
Department of Mathematics  
Trinity University  
San Antonio, Texas, USA  
[wtrench@trinity.edu](mailto:wtrench@trinity.edu)

This book has been judged to meet the evaluation criteria set by the Editorial Board of the American Institute of Mathematics in connection with the Institute's [Open Textbook Initiative](#). It may be copied, modified, redistributed, translated, and built upon subject to the Creative Commons [Attribution-NonCommercial-ShareAlike 3.0 Unported License](#).

**FREE DOWNLOAD: STUDENT SOLUTIONS MANUAL**

Free Edition 1.01 (December 2013)

This book was published previously by Brooks/Cole Thomson Learning, 2001. This free edition is made available in the hope that it will be useful as a textbook or reference. Reproduction is permitted for any valid noncommercial educational, mathematical, or scientific purpose. However, charges for profit beyond reasonable printing costs are prohibited.

**TO BEVERLY**



# Contents

<b>Chapter 1 Introduction</b>	<b>1</b>
1.1 Applications Leading to Differential Equations	
1.2 First Order Equations	5
1.3 Direction Fields for First Order Equations	16
<b>Chapter 2 First Order Equations</b>	<b>30</b>
2.1 Linear First Order Equations	30
2.2 Separable Equations	45
2.3 Existence and Uniqueness of Solutions of Nonlinear Equations	55
2.4 Transformation of Nonlinear Equations into Separable Equations	62
2.5 Exact Equations	73
2.6 Integrating Factors	82
<b>Chapter 3 Numerical Methods</b>	
3.1 Euler's Method	96
3.2 The Improved Euler Method and Related Methods	109
3.3 The Runge-Kutta Method	119
<b>Chapter 4 Applications of First Order Equations</b>	<b>130</b>
4.1 Growth and Decay	130
4.2 Cooling and Mixing	140
4.3 Elementary Mechanics	151
4.4 Autonomous Second Order Equations	162
4.5 Applications to Curves	179
<b>Chapter 5 Linear Second Order Equations</b>	
5.1 Homogeneous Linear Equations	194
5.2 Constant Coefficient Homogeneous Equations	210
5.3 Nonhomogeneous Linear Equations	221
5.4 The Method of Undetermined Coefficients I	229

5.5 The Method of Undetermined Coefficients II	238
5.6 Reduction of Order	248
5.7 Variation of Parameters	255
 Chapter 6 Applications of Linear Second Order Equations	 268
6.1 Spring Problems I	268
6.2 Spring Problems II	279
6.3 The <i>RLC</i> Circuit	290
6.4 Motion Under a Central Force	296
 Chapter 7 Series Solutions of Linear Second Order Equations	 
7.1 Review of Power Series	306
7.2 Series Solutions Near an Ordinary Point I	319
7.3 Series Solutions Near an Ordinary Point II	334
7.4 Regular Singular Points Euler Equations	342
7.5 The Method of Frobenius I	347
7.6 The Method of Frobenius II	364
7.7 The Method of Frobenius III	378
 Chapter 8 Laplace Transforms	 
8.1 Introduction to the Laplace Transform	393
8.2 The Inverse Laplace Transform	405
8.3 Solution of Initial Value Problems	413
8.4 The Unit Step Function	419
8.5 Constant Coefficient Equations with Piecewise Continuous Forcing Functions	430
8.6 Convolution	440
8.7 Constant Coefficient Equations with Impulses	452
8.8 A Brief Table of Laplace Transforms	
 Chapter 9 Linear Higher Order Equations	 
9.1 Introduction to Linear Higher Order Equations	465
9.2 Higher Order Constant Coefficient Homogeneous Equations	475
9.3 Undetermined Coefficients for Higher Order Equations	487
9.4 Variation of Parameters for Higher Order Equations	497
 Chapter 10 Linear Systems of Differential Equations	 
10.1 Introduction to Systems of Differential Equations	507
10.2 Linear Systems of Differential Equations	515
10.3 Basic Theory of Homogeneous Linear Systems	521
10.4 Constant Coefficient Homogeneous Systems I	529

<b>10.5 Constant Coefficient Homogeneous Systems II</b>	<b>542</b>
<b>10.6 Constant Coefficient Homogeneous Systems II</b>	<b>556</b>
<b>10.7 Variation of Parameters for Nonhomogeneous Linear Systems</b>	<b>568</b>
<b>Chapter 11 Boundary Value Problems and Fourier Expansions</b>	<b>580</b>
<b>11.1 Eigenvalue Problems for <math>y'' + \lambda y = 0</math></b>	<b>580</b>
<b>11.2 Fourier Series I</b>	<b>586</b>
<b>11.3 Fourier Series II</b>	<b>603</b>
<b>Chapter 12 Fourier Solutions of Partial Differential Equations</b>	
<b>12.1 The Heat Equation</b>	<b>618</b>
<b>12.2 The Wave Equation</b>	<b>630</b>
<b>12.3 Laplace's Equation in Rectangular Coordinates</b>	<b>649</b>
<b>12.4 Laplace's Equation in Polar Coordinates</b>	<b>666</b>
<b>Chapter 13 Boundary Value Problems for Second Order Linear Equations</b>	
<b>13.1 Boundary Value Problems</b>	<b>676</b>
<b>13.2 Sturm–Liouville Problems</b>	<b>687</b>

# Preface

*Elementary Differential Equations with Boundary Value Problems* is written for students in science, engineering, and mathematics who have completed calculus through partial differentiation. If your syllabus includes Chapter 10 (Linear Systems of Differential Equations), your students should have some preparation in linear algebra.

In writing this book I have been guided by the these principles:

- An elementary text should be written so the student can read it with comprehension without too much pain. I have tried to put myself in the student's place, and have chosen to err on the side of too much detail rather than not enough.
- An elementary text can't be better than its exercises. This text includes 2041 numbered exercises, many with several parts. They range in difficulty from routine to very challenging.
- An elementary text should be written in an informal but mathematically accurate way, illustrated by appropriate graphics. I have tried to formulate mathematical concepts succinctly in language that students can understand. I have minimized the number of explicitly stated theorems and definitions, preferring to deal with concepts in a more conversational way, copiously illustrated by 299 completely worked out examples. Where appropriate, concepts and results are depicted in 188 figures.

Although I believe that the computer is an immensely valuable tool for learning, doing, and writing mathematics, the selection and treatment of topics in this text reflects my pedagogical orientation along traditional lines. However, I have incorporated what I believe to be the best use of modern technology, so you can select the level of technology that you want to include in your course. The text includes 414 exercises – identified by the symbols **C** and **C/G** – that call for graphics or computation and graphics. There are also 79 laboratory exercises – identified by **L** – that require extensive use of technology. In addition, several sections include informal advice on the use of technology. If you prefer not to emphasize technology, simply ignore these exercises and the advice.

There are two schools of thought on whether techniques and applications should be treated together or separately. I have chosen to separate them; thus, Chapter 2 deals with techniques for solving first order equations, and Chapter 4 deals with applications. Similarly, Chapter 5 deals with techniques for solving second order equations, and Chapter 6 deals with applications. However, the exercise sets of the sections dealing with techniques include some applied problems.

Traditionally oriented elementary differential equations texts are occasionally criticized as being collections of unrelated methods for solving miscellaneous problems. To some extent this is true; after all, no single method applies to all situations. Nevertheless, I believe that one idea can go a long way toward unifying some of the techniques for solving diverse problems: variation of parameters. I use variation of parameters at the earliest opportunity in Section 2.1, to solve the nonhomogeneous linear equation, given a nontrivial solution of the complementary equation. You may find this annoying, since most of us learned that one should use integrating factors for this task, while perhaps mentioning the variation of parameters option in an exercise. However, there's little difference between the two approaches, since an integrating factor is nothing more than the reciprocal of a nontrivial solution of the complementary equation. The advantage of using variation of parameters here is that it introduces the concept in its simplest form and

focuses the student's attention on the idea of seeking a solution  $y$  of a differential equation by writing it as  $y = uy_1$ , where  $y_1$  is a known solution of related equation and  $u$  is a function to be determined. I use this idea in nonstandard ways, as follows:

- In Section 2.4 to solve nonlinear first order equations, such as Bernoulli equations and nonlinear homogeneous equations.
- In Chapter 3 for numerical solution of semilinear first order equations.
- In Section 5.2 to avoid the necessity of introducing complex exponentials in solving a second order constant coefficient homogeneous equation with characteristic polynomials that have complex zeros.
- In Sections 5.4, 5.5, and 9.3 for the method of undetermined coefficients. (If the method of annihilators is your preferred approach to this problem, compare the labor involved in solving, for example,  $y'' + y' + y = x^4e^x$  by the method of annihilators and the method used in Section 5.4.)

Introducing variation of parameters as early as possible (Section 2.1) prepares the student for the concept when it appears again in more complex forms in Section 5.6, where reduction of order is used not merely to find a second solution of the complementary equation, but also to find the general solution of the nonhomogeneous equation, and in Sections 5.7, 9.4, and 10.7, that treat the usual variation of parameters problem for second and higher order linear equations and for linear systems.

Chapter 11 develops the theory of Fourier series. Section 11.1 discusses the five main eigenvalue problems that arise in connection with the method of separation of variables for the heat and wave equations and for Laplace's equation over a rectangular domain:

$$\text{Problem 1:} \quad y'' + \lambda y = 0, \quad y(0) = 0, \quad y(L) = 0$$

$$\text{Problem 2:} \quad y'' + \lambda y = 0, \quad y'(0) = 0, \quad y'(L) = 0$$

$$\text{Problem 3:} \quad y'' + \lambda y = 0, \quad y(0) = 0, \quad y'(L) = 0$$

$$\text{Problem 4:} \quad y'' + \lambda y = 0, \quad y'(0) = 0, \quad y(L) = 0$$

$$\text{Problem 5:} \quad y'' + \lambda y = 0, \quad y(-L) = y(L), \quad y'(-L) = y'(L)$$

These problems are handled in a unified way for example, a single theorem shows that the eigenvalues of all five problems are nonnegative.

Section 11.2 presents the Fourier series expansion of functions defined on  $[-L, L]$ , interpreting it as an expansion in terms of the eigenfunctions of Problem 5.

Section 11.3 presents the Fourier sine and cosine expansions of functions defined on  $[0, L]$ , interpreting them as expansions in terms of the eigenfunctions of Problems 1 and 2, respectively. In addition, Section 11.2 includes what I call the mixed Fourier sine and cosine expansions, in terms of the eigenfunctions of Problems 4 and 5, respectively. In all cases, the convergence properties of these series are deduced from the convergence properties of the Fourier series discussed in Section 11.1.

Chapter 12 consists of four sections devoted to the heat equation, the wave equation, and Laplace's equation in rectangular and polar coordinates. For all three, I consider homogeneous boundary conditions of the four types occurring in Problems 1-4. I present the method of separation of variables as a way of choosing the appropriate form for the series expansion of the solution of the given problem, stating—without belaboring the point—that the expansion may fall short of being an actual solution, and giving an indication of conditions under which the formal solution is an actual solution. In particular, I found it necessary to devote some detail to this question in connection with the wave equation in Section 12.2.

In Sections 12.1 (The Heat Equation) and 12.2 (The Wave Equation) I devote considerable effort to devising examples and numerous exercises where the functions defining the initial conditions satisfy

the homogeneous boundary conditions. Similarly, in most of the examples and exercises Section 12.3 (Laplace's Equation), the functions defining the boundary conditions on a given side of the rectangular domain satisfy homogeneous boundary conditions at the endpoints of the same type (Dirichlet or Neumann) as the boundary conditions imposed on adjacent sides of the region. Therefore the formal solutions obtained in many of the examples and exercises are actual solutions.

Section 13.1 deals with two-point value problems for a second order ordinary differential equation. Conditions for existence and uniqueness of solutions are given, and the construction of Green's functions is included.

Section 13.2 presents the elementary aspects of Sturm-Liouville theory.

You may also find the following to be of interest:

- Section 2.6 deals with integrating factors of the form  $\mu = p(x)q(y)$ , in addition to those of the form  $\mu = p(x)$  and  $\mu = q(y)$  discussed in most texts.
- Section 4.4 makes phase plane analysis of nonlinear second order autonomous equations accessible to students who have not taken linear algebra, since eigenvalues and eigenvectors do not enter into the treatment. Phase plane analysis of constant coefficient linear systems is included in Sections 10.4-6.
- Section 4.5 presents an extensive discussion of applications of differential equations to curves.
- Section 6.4 studies motion under a central force, which may be useful to students interested in the mathematics of satellite orbits.
- Sections 7.5-7 present the method of Frobenius in more detail than in most texts. The approach is to systematize the computations in a way that avoids the necessity of substituting the unknown Frobenius series into each equation. This leads to efficiency in the computation of the coefficients of the Frobenius solution. It also clarifies the case where the roots of the indicial equation differ by an integer (Section 7.7).
- The free Student Solutions Manual contains solutions of most of the even-numbered exercises.
- The free Instructor's Solutions Manual is available by email to [wrench@trinity.edu](mailto:wrench@trinity.edu), subject to verification of the requestor's faculty status.

The following observations may be helpful as you choose your syllabus:

- Section 2.3 is the only specific prerequisite for Chapter 3. To accommodate institutions that offer a separate course in numerical analysis, Chapter 3 is not a prerequisite for any other section in the text.
- The sections in Chapter 4 are independent of each other, and are not prerequisites for any of the later chapters. This is also true of the sections in Chapter 6, except that Section 6.1 is a prerequisite for Section 6.2.
- Chapters 7, 8, and 9 can be covered in any order after the topics selected from Chapter 5. For example, you can proceed directly from Chapter 5 to Chapter 9.
- The second order Euler equation is discussed in Section 7.4, where it sets the stage for the method of Frobenius. As noted at the beginning of Section 7.4, if you want to include Euler equations in your syllabus while omitting the method of Frobenius, you can skip the introductory paragraphs in Section 7.4 and begin with Definition 7.4.2. You can then cover Section 7.4 immediately after Section 5.2.
- Chapters 11, 12, and 13 can be covered at any time after the completion of Chapter 5.

# **CHAPTER 1**

## **Introduction**

IN THIS CHAPTER we begin our study of differential equations.

SECTION 1.1 presents examples of applications that lead to differential equations.

SECTION 1.2 introduces basic concepts and definitions concerning differential equations.

SECTION 1.3 presents a geometric method for dealing with differential equations that has been known for a very long time, but has become particularly useful and important with the proliferation of readily available differential equations software.

## 1.1 APPLICATIONS LEADING TO DIFFERENTIAL EQUATIONS

In order to apply mathematical methods to a physical or “real life” problem, we must formulate the problem in mathematical terms; that is, we must construct a *mathematical model* for the problem. Many physical problems concern relationships between changing quantities. Since rates of change are represented mathematically by derivatives, mathematical models often involve equations relating an unknown function and one or more of its derivatives. Such equations are *differential equations*. They are the subject of this book.

Much of calculus is devoted to learning mathematical techniques that are applied in later courses in mathematics and the sciences; you wouldn’t have time to learn much calculus if you insisted on seeing a specific application of every topic covered in the course. Similarly, much of this book is devoted to methods that can be applied in later courses. Only a relatively small part of the book is devoted to the derivation of specific differential equations from mathematical models, or relating the differential equations that we study to specific applications. In this section we mention a few such applications.

The mathematical model for an applied problem is almost always simpler than the actual situation being studied, since simplifying assumptions are usually required to obtain a mathematical problem that can be solved. For example, in modeling the motion of a falling object, we might neglect air resistance and the gravitational pull of celestial bodies other than Earth, or in modeling population growth we might assume that the population grows continuously rather than in discrete steps.

A good mathematical model has two important properties:

- It’s sufficiently simple so that the mathematical problem can be solved.
- It represents the actual situation sufficiently well so that the solution to the mathematical problem predicts the outcome of the real problem to within a useful degree of accuracy. If results predicted by the model don’t agree with physical observations, the underlying assumptions of the model must be revised until satisfactory agreement is obtained.

We’ll now give examples of mathematical models involving differential equations. We’ll return to these problems at the appropriate times, as we learn how to solve the various types of differential equations that occur in the models.

All the examples in this section deal with functions of time, which we denote by  $t$ . If  $y$  is a function of  $t$ ,  $y'$  denotes the derivative of  $y$  with respect to  $t$ ; thus,

$$y' = \frac{dy}{dt}.$$

### Population Growth and Decay

Although the number of members of a population (people in a given country, bacteria in a laboratory culture, wildflowers in a forest, etc.) at any given time  $t$  is necessarily an integer, models that use differential equations to describe the growth and decay of populations usually rest on the simplifying assumption that the number of members of the population can be regarded as a differentiable function  $P = P(t)$ . In most models it is assumed that the differential equation takes the form

$$P' = a(P)P, \tag{1.1.1}$$

where  $a$  is a continuous function of  $P$  that represents the rate of change of population per unit time per individual. In the *Malthusian model*, it is assumed that  $a(P)$  is a constant, so (1.1.1) becomes

$$P' = aP. \tag{1.1.2}$$



(When you see a name in blue italics, just click on it for information about the person.) This model assumes that the numbers of births and deaths per unit time are both proportional to the population. The constants of proportionality are the *birth rate* (births per unit time per individual) and the *death rate* (deaths per unit time per individual);  $a$  is the birth rate minus the death rate. You learned in calculus that if  $c$  is any constant then

$$P = ce^{at} \quad (1.1.3)$$

satisfies (1.1.2), so (1.1.2) has infinitely many solutions. To select the solution of the specific problem that we're considering, we must know the population  $P_0$  at an initial time, say  $t = 0$ . Setting  $t = 0$  in (1.1.3) yields  $c = P(0) = P_0$ , so the applicable solution is

$$P(t) = P_0e^{at}.$$

This implies that

$$\lim_{t \rightarrow \infty} P(t) = \begin{cases} \infty & \text{if } a > 0, \\ 0 & \text{if } a < 0; \end{cases}$$

that is, the population approaches infinity if the birth rate exceeds the death rate, or zero if the death rate exceeds the birth rate.

To see the limitations of the Malthusian model, suppose we're modeling the population of a country, starting from a time  $t = 0$  when the birth rate exceeds the death rate (so  $a > 0$ ), and the country's resources in terms of space, food supply, and other necessities of life can support the existing population. Then the prediction  $P = P_0e^{at}$  may be reasonably accurate as long as it remains within limits that the country's resources can support. However, the model must inevitably lose validity when the prediction exceeds these limits. (If nothing else, eventually there won't be enough space for the predicted population!)

This flaw in the Malthusian model suggests the need for a model that accounts for limitations of space and resources that tend to oppose the rate of population growth as the population increases. Perhaps the most famous model of this kind is the *Verhulst model*, where (1.1.2) is replaced by

$$P' = aP(1 - \alpha P), \quad (1.1.4)$$

where  $\alpha$  is a positive constant. As long as  $P$  is small compared to  $1/\alpha$ , the ratio  $P'/P$  is approximately equal to  $a$ . Therefore the growth is approximately exponential; however, as  $P$  increases, the ratio  $P'/P$  decreases as opposing factors become significant.

Equation (1.1.4) is the *logistic equation*. You will learn how to solve it in Section 1.2. (See Exercise 2.2.28.) The solution is

$$P = \frac{P_0}{\alpha P_0 + (1 - \alpha P_0)e^{-at}},$$

where  $P_0 = P(0) > 0$ . Therefore  $\lim_{t \rightarrow \infty} P(t) = 1/\alpha$ , independent of  $P_0$ .

Figure 1.1.1 shows typical graphs of  $P$  versus  $t$  for various values of  $P_0$ .

### Newton's Law of Cooling

According to *Newton's law of cooling*, the temperature of a body changes at a rate proportional to the difference between the temperature of the body and the temperature of the surrounding medium. Thus, if  $T_m$  is the temperature of the medium and  $T = T(t)$  is the temperature of the body at time  $t$ , then

$$T' = -k(T - T_m), \quad (1.1.5)$$

where  $k$  is a positive constant and the minus sign indicates; that the temperature of the body increases with time if it's less than the temperature of the medium, or decreases if it's greater. We'll see in Section 4.2 that if  $T_m$  is constant then the solution of (1.1.5) is

$$T = T_m + (T_0 - T_m)e^{-kt}, \quad (1.1.6)$$

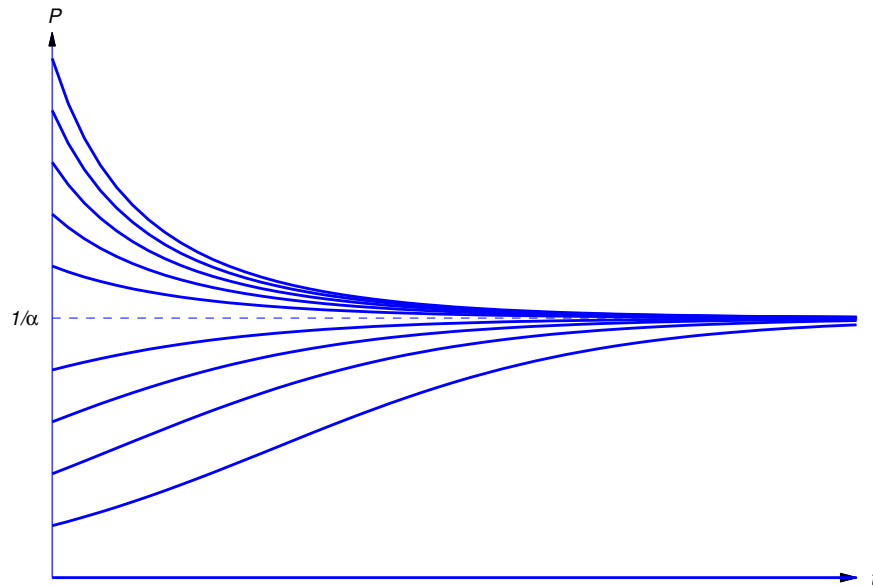

Figure 1.1.1 Solutions of the logistic equation

where  $T_0$  is the temperature of the body when  $t = 0$ . Therefore  $\lim_{t \rightarrow \infty} T(t) = T_m$ , independent of  $T_0$ . (Common sense suggests this. Why?)

Figure 1.1.2 shows typical graphs of  $T$  versus  $t$  for various values of  $T_0$ .

Assuming that the medium remains at constant temperature seems reasonable if we're considering a cup of coffee cooling in a room, but not if we're cooling a huge cauldron of molten metal in the same room. The difference between the two situations is that the heat lost by the coffee isn't likely to raise the temperature of the room appreciably, but the heat lost by the cooling metal is. In this second situation we must use a model that accounts for the heat exchanged between the object and the medium. Let  $T = T(t)$  and  $T_m = T_m(t)$  be the temperatures of the object and the medium respectively, and let  $T_0$  and  $T_{m0}$  be their initial values. Again, we assume that  $T$  and  $T_m$  are related by (1.1.5). We also assume that the change in heat of the object as its temperature changes from  $T_0$  to  $T$  is  $a(T - T_0)$  and the change in heat of the medium as its temperature changes from  $T_{m0}$  to  $T_m$  is  $a_m(T_m - T_{m0})$ , where  $a$  and  $a_m$  are positive constants depending upon the masses and thermal properties of the object and medium respectively. If we assume that the total heat of the in the object and the medium remains constant (that is, energy is conserved), then

$$a(T - T_0) + a_m(T_m - T_{m0}) = 0.$$

Solving this for  $T_m$  and substituting the result into (1.1.6) yields the differential equation

$$T' = -k \left( 1 + \frac{a}{a_m} \right) T + k \left( T_{m0} + \frac{a}{a_m} T_0 \right)$$

for the temperature of the object. After learning to solve linear first order equations, you'll be able to show (Exercise 4.2.17) that

$$T = \frac{aT_0 + a_m T_{m0}}{a + a_m} + \frac{a_m(T_0 - T_{m0})}{a + a_m} e^{-k(1+a/a_m)t}.$$

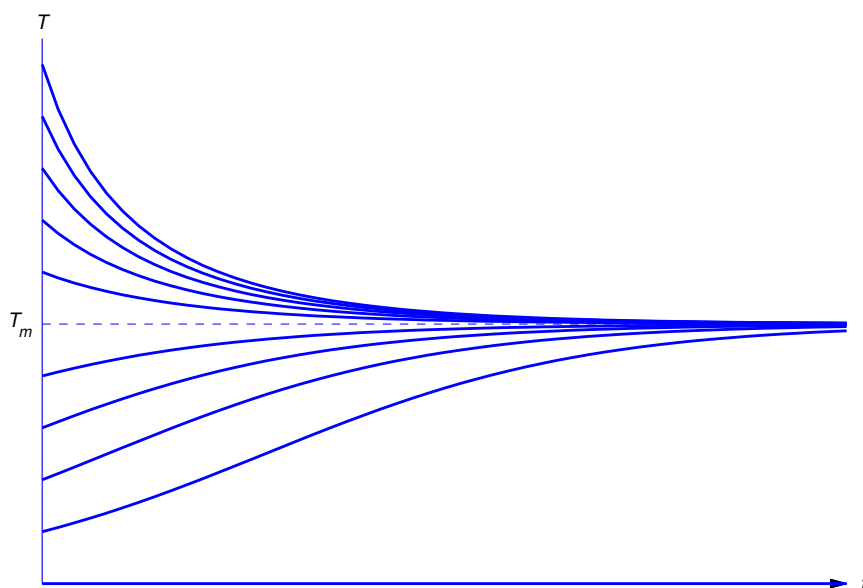

Figure 1.1.2 Temperature according to Newton's Law of Cooling

### Glucose Absorption by the Body

Glucose is absorbed by the body at a rate proportional to the amount of glucose present in the bloodstream. Let  $\lambda$  denote the (positive) constant of proportionality. Suppose there are  $G_0$  units of glucose in the bloodstream when  $t = 0$ , and let  $G = G(t)$  be the number of units in the bloodstream at time  $t > 0$ . Then, since the glucose being absorbed by the body is leaving the bloodstream,  $G$  satisfies the equation

$$G' = -\lambda G. \quad (1.1.7)$$

From calculus you know that if  $c$  is any constant then

$$G = ce^{-\lambda t} \quad (1.1.8)$$

satisfies (1.1.7), so (1.1.7) has infinitely many solutions. Setting  $t = 0$  in (1.1.8) and requiring that  $G(0) = G_0$  yields  $c = G_0$ , so

$$G(t) = G_0 e^{-\lambda t}.$$

Now let's complicate matters by injecting glucose intravenously at a constant rate of  $r$  units of glucose per unit of time. Then the rate of change of the amount of glucose in the bloodstream per unit time is

$$G' = -\lambda G + r, \quad (1.1.9)$$

where the first term on the right is due to the absorption of the glucose by the body and the second term is due to the injection. After you've studied Section 2.1, you'll be able to show (Exercise 2.1.43) that the solution of (1.1.9) that satisfies  $G(0) = G_0$  is

$$G = \frac{r}{\lambda} + \left(G_0 - \frac{r}{\lambda}\right) e^{-\lambda t}.$$

Graphs of this function are similar to those in Figure 1.1.2. (Why?)

### Spread of Epidemics

One model for the spread of epidemics assumes that the number of people infected changes at a rate proportional to the product of the number of people already infected and the number of people who are susceptible, but not yet infected. Therefore, if  $S$  denotes the total population of susceptible people and  $I = I(t)$  denotes the number of infected people at time  $t$ , then  $S - I$  is the number of people who are susceptible, but not yet infected. Thus,

$$I' = rI(S - I),$$

where  $r$  is a positive constant. Assuming that  $I(0) = I_0$ , the solution of this equation is

$$I = \frac{SI_0}{I_0 + (S - I_0)e^{-rSt}}$$

(Exercise 2.2.29). Graphs of this function are similar to those in Figure 1.1.1. (Why?) Since  $\lim_{t \rightarrow \infty} I(t) = S$ , this model predicts that all the susceptible people eventually become infected.

### Newton's Second Law of Motion

According to *Newton's second law of motion*, the instantaneous acceleration  $a$  of an object with constant mass  $m$  is related to the force  $F$  acting on the object by the equation  $F = ma$ . For simplicity, let's assume that  $m = 1$  and the motion of the object is along a vertical line. Let  $y$  be the displacement of the object from some reference point on Earth's surface, measured positive upward. In many applications, there are three kinds of forces that may act on the object:

- (a) A force such as gravity that depends only on the position  $y$ , which we write as  $-p(y)$ , where  $p(y) > 0$  if  $y \geq 0$ .
- (b) A force such as atmospheric resistance that depends on the position and velocity of the object, which we write as  $-q(y, y')y'$ , where  $q$  is a nonnegative function and we've put  $y'$  "outside" to indicate that the resistive force is always in the direction opposite to the velocity.
- (c) A force  $f = f(t)$ , exerted from an external source (such as a towline from a helicopter) that depends only on  $t$ .

In this case, Newton's second law implies that

$$y'' = -q(y, y')y' - p(y) + f(t),$$

which is usually rewritten as

$$y'' + q(y, y')y' + p(y) = f(t).$$

Since the second (and no higher) order derivative of  $y$  occurs in this equation, we say that it is a *second order differential equation*.

### Interacting Species: Competition

Let  $P = P(t)$  and  $Q = Q(t)$  be the populations of two species at time  $t$ , and assume that each population would grow exponentially if the other didn't exist; that is, in the absence of competition we would have

$$P' = aP \quad \text{and} \quad Q' = bQ, \tag{1.1.10}$$

where  $a$  and  $b$  are positive constants. One way to model the effect of competition is to assume that the growth rate per individual of each population is reduced by an amount proportional to the other population, so (1.1.10) is replaced by

$$\begin{aligned} P' &= aP - \alpha Q \\ Q' &= -\beta P + bQ, \end{aligned}$$

where  $\alpha$  and  $\beta$  are positive constants. (Since negative population doesn't make sense, this system works only while  $P$  and  $Q$  are both positive.) Now suppose  $P(0) = P_0 > 0$  and  $Q(0) = Q_0 > 0$ . It can be shown (Exercise 10.4.42) that there's a positive constant  $\rho$  such that if  $(P_0, Q_0)$  is above the line  $L$  through the origin with slope  $\rho$ , then the species with population  $P$  becomes extinct in finite time, but if  $(P_0, Q_0)$  is below  $L$ , the species with population  $Q$  becomes extinct in finite time. Figure 1.1.3 illustrates this. The curves shown there are given parametrically by  $P = P(t), Q = Q(t), t > 0$ . The arrows indicate direction along the curves with increasing  $t$ .

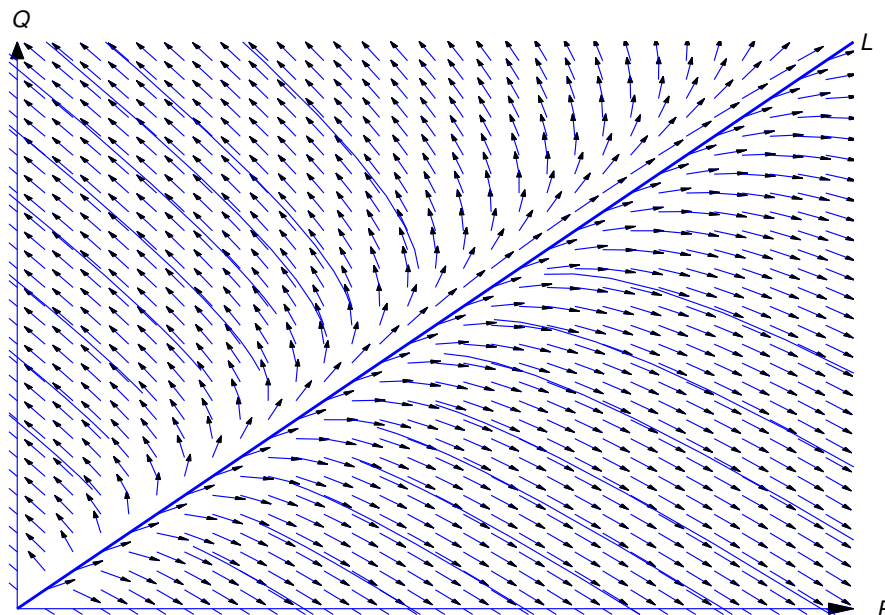

Figure 1.1.3 Populations of competing species

## 1.2 BASIC CONCEPTS

A *differential equation* is an equation that contains one or more derivatives of an unknown function. The *order* of a differential equation is the order of the highest derivative that it contains. A differential equation is an *ordinary differential equation* if it involves an unknown function of only one variable, or a *partial differential equation* if it involves partial derivatives of a function of more than one variable. For now we'll consider only ordinary differential equations, and we'll just call them *differential equations*.

Throughout this text, all variables and constants are real unless it's stated otherwise. We'll usually use  $x$  for the independent variable unless the independent variable is time; then we'll use  $t$ .

The simplest differential equations are first order equations of the form

$$\frac{dy}{dx} = f(x) \quad \text{or, equivalently,} \quad y' = f(x),$$

where  $f$  is a known function of  $x$ . We already know from calculus how to find functions that satisfy this kind of equation. For example, if

$$y' = x^3,$$

then

$$y = \int x^3 dx = \frac{x^4}{4} + c,$$

where  $c$  is an arbitrary constant. If  $n > 1$  we can find functions  $y$  that satisfy equations of the form

$$y^{(n)} = f(x) \tag{1.2.1}$$

by repeated integration. Again, this is a calculus problem.

Except for illustrative purposes in this section, there's no need to consider differential equations like (1.2.1). We'll usually consider differential equations that can be written as

$$y^{(n)} = f(x, y, y', \dots, y^{(n-1)}), \tag{1.2.2}$$

where at least one of the functions  $y, y', \dots, y^{(n-1)}$  actually appears on the right. Here are some examples:

$$\begin{aligned} \frac{dy}{dx} - x^2 &= 0 && \text{(first order),} \\ \frac{dy}{dx} + 2xy^2 &= -2 && \text{(first order),} \\ \frac{d^2y}{dx^2} + 2\frac{dy}{dx} + y &= 2x && \text{(second order),} \\ xy''' + y^2 &= \sin x && \text{(third order),} \\ y^{(n)} + xy' + 3y &= x && \text{(n-th order).} \end{aligned}$$

Although none of these equations is written as in (1.2.2), all of them *can* be written in this form:

$$\begin{aligned} y' &= x^2, \\ y' &= -2 - 2xy^2, \\ y'' &= 2x - 2y' - y, \\ y''' &= \frac{\sin x - y^2}{x}, \\ y^{(n)} &= x - xy' - 3y. \end{aligned}$$

### Solutions of Differential Equations

A *solution* of a differential equation is a function that satisfies the differential equation on some open interval; thus,  $y$  is a solution of (1.2.2) if  $y$  is  $n$  times differentiable and

$$y^{(n)}(x) = f(x, y(x), y'(x), \dots, y^{(n-1)}(x))$$

for all  $x$  in some open interval  $(a, b)$ . In this case, we also say that  $y$  is a *solution of (1.2.2) on  $(a, b)$* . Functions that satisfy a differential equation at isolated points are not interesting. For example,  $y = x^2$  satisfies

$$xy' + x^2 = 3x$$

if and only if  $x = 0$  or  $x = 1$ , but it's not a solution of this differential equation because it does not satisfy the equation on an open interval.

The graph of a solution of a differential equation is a *solution curve*. More generally, a curve  $C$  is said to be an *integral curve* of a differential equation if every function  $y = y(x)$  whose graph is a segment of  $C$  is a solution of the differential equation. Thus, any solution curve of a differential equation is an integral curve, but an integral curve need not be a solution curve.

**Example 1.2.1** If  $a$  is any positive constant, the circle

$$x^2 + y^2 = a^2 \quad (1.2.3)$$

is an integral curve of

$$y' = -\frac{x}{y}. \quad (1.2.4)$$

To see this, note that the only functions whose graphs are segments of (1.2.3) are

$$y_1 = \sqrt{a^2 - x^2} \quad \text{and} \quad y_2 = -\sqrt{a^2 - x^2}.$$

We leave it to you to verify that these functions both satisfy (1.2.4) on the open interval  $(-a, a)$ . However, (1.2.3) is not a solution curve of (1.2.4), since it's not the graph of a function.

**Example 1.2.2** Verify that

$$y = \frac{x^2}{3} + \frac{1}{x} \quad (1.2.5)$$

is a solution of

$$xy' + y = x^2 \quad (1.2.6)$$

on  $(0, \infty)$  and on  $(-\infty, 0)$ .

**Solution** Substituting (1.2.5) and

$$y' = \frac{2x}{3} - \frac{1}{x^2}$$

into (1.2.6) yields

$$xy'(x) + y(x) = x \left( \frac{2x}{3} - \frac{1}{x^2} \right) + \left( \frac{x^2}{3} + \frac{1}{x} \right) = x^2$$

for all  $x \neq 0$ . Therefore  $y$  is a solution of (1.2.6) on  $(-\infty, 0)$  and  $(0, \infty)$ . However,  $y$  isn't a solution of the differential equation on any open interval that contains  $x = 0$ , since  $y$  is not defined at  $x = 0$ .

Figure 1.2.1 shows the graph of (1.2.5). The part of the graph of (1.2.5) on  $(0, \infty)$  is a solution curve of (1.2.6), as is the part of the graph on  $(-\infty, 0)$ .

**Example 1.2.3** Show that if  $c_1$  and  $c_2$  are constants then

$$y = (c_1 + c_2x)e^{-x} + 2x - 4 \quad (1.2.7)$$

is a solution of

$$y'' + 2y' + y = 2x \quad (1.2.8)$$

on  $(-\infty, \infty)$ .

**Solution** Differentiating (1.2.7) twice yields

$$y' = -(c_1 + c_2x)e^{-x} + c_2e^{-x} + 2$$

and

$$y'' = (c_1 + c_2x)e^{-x} - 2c_2e^{-x},$$

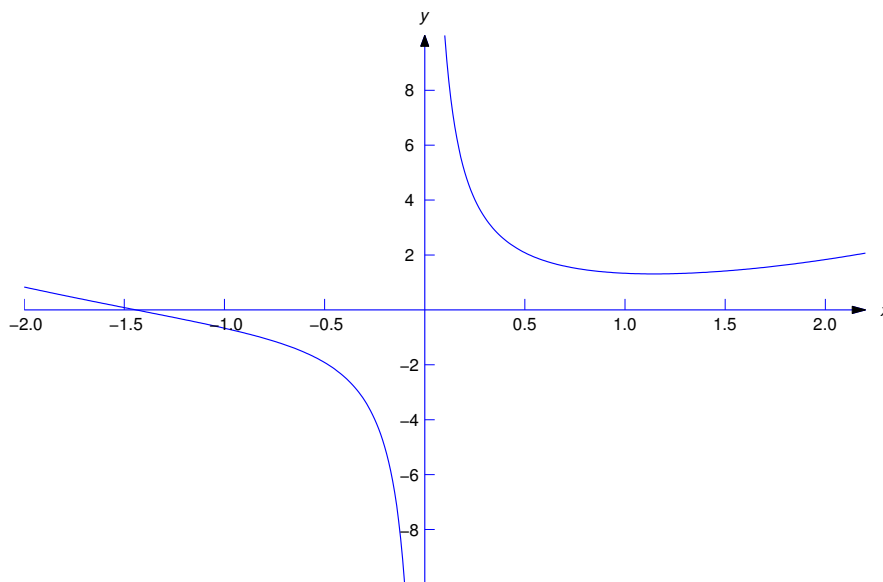

Figure 1.2.1  $y = \frac{x^2}{3} + \frac{1}{x}$

so

$$\begin{aligned}
 y'' + 2y' + y &= (c_1 + c_2x)e^{-x} - 2c_2e^{-x} \\
 &\quad + 2[-(c_1 + c_2x)e^{-x} + c_2e^{-x} + 2] \\
 &\quad + (c_1 + c_2x)e^{-x} + 2x - 4 \\
 &= (1 - 2 + 1)(c_1 + c_2x)e^{-x} + (-2 + 2)c_2e^{-x} \\
 &\quad + 4 + 2x - 4 = 2x
 \end{aligned}$$

for all values of  $x$ . Therefore  $y$  is a solution of (1.2.8) on  $(-\infty, \infty)$ .

**Example 1.2.4** Find all solutions of

$$y^{(n)} = e^{2x}. \quad (1.2.9)$$

**Solution** Integrating (1.2.9) yields

$$y^{(n-1)} = \frac{e^{2x}}{2} + k_1,$$

where  $k_1$  is a constant. If  $n \geq 2$ , integrating again yields

$$y^{(n-2)} = \frac{e^{2x}}{4} + k_1x + k_2.$$

If  $n \geq 3$ , repeatedly integrating yields

$$y = \frac{e^{2x}}{2^n} + k_1 \frac{x^{n-1}}{(n-1)!} + k_2 \frac{x^{n-2}}{(n-2)!} + \cdots + k_n, \quad (1.2.10)$$



where  $k_1, k_2, \dots, k_n$  are constants. This shows that every solution of (1.2.9) has the form (1.2.10) for some choice of the constants  $k_1, k_2, \dots, k_n$ . On the other hand, differentiating (1.2.10)  $n$  times shows that if  $k_1, k_2, \dots, k_n$  are arbitrary constants, then the function  $y$  in (1.2.10) satisfies (1.2.9).

Since the constants  $k_1, k_2, \dots, k_n$  in (1.2.10) are arbitrary, so are the constants

$$\frac{k_1}{(n-1)!}, \frac{k_2}{(n-2)!}, \dots, k_n.$$

Therefore Example 1.2.4 actually shows that all solutions of (1.2.9) can be written as

$$y = \frac{e^{2x}}{2^n} + c_1 + c_2x + \dots + c_nx^{n-1},$$

where we renamed the arbitrary constants in (1.2.10) to obtain a simpler formula. As a general rule, arbitrary constants appearing in solutions of differential equations should be simplified if possible. You'll see examples of this throughout the text.

### Initial Value Problems

In Example 1.2.4 we saw that the differential equation  $y^{(n)} = e^{2x}$  has an infinite family of solutions that depend upon the  $n$  arbitrary constants  $c_1, c_2, \dots, c_n$ . In the absence of additional conditions, there's no reason to prefer one solution of a differential equation over another. However, we'll often be interested in finding a solution of a differential equation that satisfies one or more specific conditions. The next example illustrates this.

**Example 1.2.5** Find a solution of

$$y' = x^3$$

such that  $y(1) = 2$ .

**Solution** At the beginning of this section we saw that the solutions of  $y' = x^3$  are

$$y = \frac{x^4}{4} + c.$$

To determine a value of  $c$  such that  $y(1) = 2$ , we set  $x = 1$  and  $y = 2$  here to obtain

$$2 = y(1) = \frac{1}{4} + c, \quad \text{so} \quad c = \frac{7}{4}.$$

Therefore the required solution is

$$y = \frac{x^4 + 7}{4}.$$

Figure 1.2.2 shows the graph of this solution. Note that imposing the condition  $y(1) = 2$  is equivalent to requiring the graph of  $y$  to pass through the point  $(1, 2)$ .

We can rewrite the problem considered in Example 1.2.5 more briefly as

$$y' = x^3, \quad y(1) = 2.$$

We call this an *initial value problem*. The requirement  $y(1) = 2$  is an *initial condition*. Initial value problems can also be posed for higher order differential equations. For example,

$$y'' - 2y' + 3y = e^x, \quad y(0) = 1, \quad y'(0) = 2 \quad (1.2.11)$$

is an initial value problem for a second order differential equation where  $y$  and  $y'$  are required to have specified values at  $x = 0$ . In general, an initial value problem for an  $n$ -th order differential equation requires  $y$  and its first  $n - 1$  derivatives to have specified values at some point  $x_0$ . These requirements are the *initial conditions*.

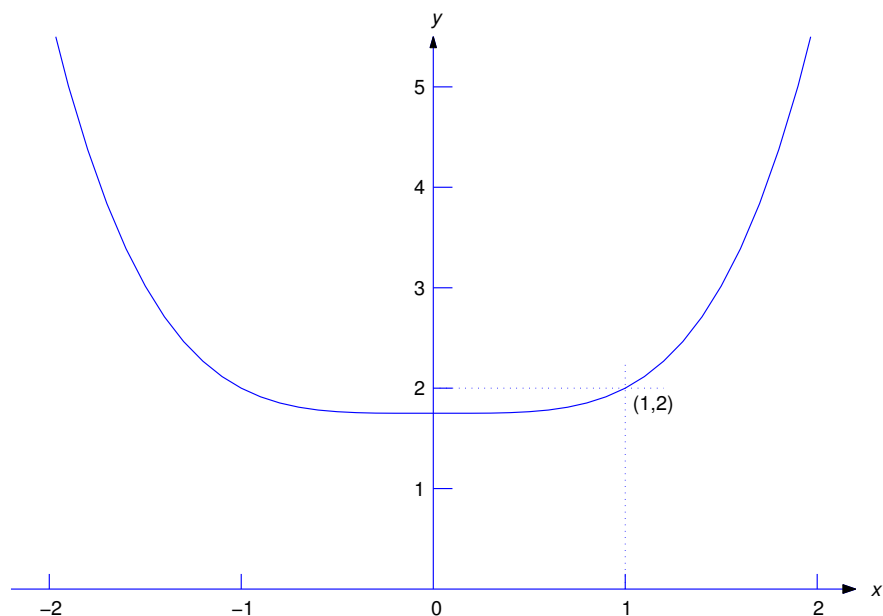

Figure 1.2.2  $y = \frac{x^2 + 7}{4}$

We'll denote an initial value problem for a differential equation by writing the initial conditions after the equation, as in (1.2.11). For example, we would write an initial value problem for (1.2.2) as

$$y^{(n)} = f(x, y, y', \dots, y^{(n-1)}), \quad y(x_0) = k_0, \quad y'(x_0) = k_1, \quad \dots, \quad y^{(n-1)}(x_0) = k_{n-1}. \quad (1.2.12)$$

Consistent with our earlier definition of a solution of the differential equation in (1.2.12), we say that  $y$  is a solution of the initial value problem (1.2.12) if  $y$  is  $n$  times differentiable and

$$y^{(n)}(x) = f(x, y(x), y'(x), \dots, y^{(n-1)}(x))$$

for all  $x$  in some open interval  $(a, b)$  that contains  $x_0$ , and  $y$  satisfies the initial conditions in (1.2.12). The largest open interval that contains  $x_0$  on which  $y$  is defined and satisfies the differential equation is the *interval of validity* of  $y$ .

**Example 1.2.6** In Example 1.2.5 we saw that

$$y = \frac{x^4 + 7}{4} \quad (1.2.13)$$

is a solution of the initial value problem

$$y' = x^3, \quad y(1) = 2.$$

Since the function in (1.2.13) is defined for all  $x$ , the interval of validity of this solution is  $(-\infty, \infty)$ .

**Example 1.2.7** In Example 1.2.2 we verified that

$$y = \frac{x^2}{3} + \frac{1}{x} \quad (1.2.14)$$

is a solution of

$$xy' + y = x^2$$

on  $(0, \infty)$  and on  $(-\infty, 0)$ . By evaluating (1.2.14) at  $x = \pm 1$ , you can see that (1.2.14) is a solution of the initial value problems

$$xy' + y = x^2, \quad y(1) = \frac{4}{3} \quad (1.2.15)$$

and

$$xy' + y = x^2, \quad y(-1) = -\frac{2}{3}. \quad (1.2.16)$$

The interval of validity of (1.2.14) as a solution of (1.2.15) is  $(0, \infty)$ , since this is the largest interval that contains  $x_0 = 1$  on which (1.2.14) is defined. Similarly, the interval of validity of (1.2.14) as a solution of (1.2.16) is  $(-\infty, 0)$ , since this is the largest interval that contains  $x_0 = -1$  on which (1.2.14) is defined.

### Free Fall Under Constant Gravity

The term *initial value problem* originated in problems of motion where the independent variable is  $t$  (representing elapsed time), and the initial conditions are the position and velocity of an object at the initial (starting) time of an experiment.

**Example 1.2.8** An object falls under the influence of gravity near Earth's surface, where it can be assumed that the magnitude of the acceleration due to gravity is a constant  $g$ .

- (a) Construct a mathematical model for the motion of the object in the form of an initial value problem for a second order differential equation, assuming that the altitude and velocity of the object at time  $t = 0$  are known. Assume that gravity is the only force acting on the object.
- (b) Solve the initial value problem derived in (a) to obtain the altitude as a function of time.

**SOLUTION(a)** Let  $y(t)$  be the altitude of the object at time  $t$ . Since the acceleration of the object has constant magnitude  $g$  and is in the downward (negative) direction,  $y$  satisfies the second order equation

$$y'' = -g,$$

where the prime now indicates differentiation with respect to  $t$ . If  $y_0$  and  $v_0$  denote the altitude and velocity when  $t = 0$ , then  $y$  is a solution of the initial value problem

$$y'' = -g, \quad y(0) = y_0, \quad y'(0) = v_0. \quad (1.2.17)$$

**SOLUTION(b)** Integrating (1.2.17) twice yields

$$\begin{aligned} y' &= -gt + c_1, \\ y &= -\frac{gt^2}{2} + c_1t + c_2. \end{aligned}$$

Imposing the initial conditions  $y(0) = y_0$  and  $y'(0) = v_0$  in these two equations shows that  $c_1 = v_0$  and  $c_2 = y_0$ . Therefore the solution of the initial value problem (1.2.17) is

$$y = -\frac{gt^2}{2} + v_0t + y_0.$$

## 1.2 Exercises

1. Find the order of the equation.

(a)  $\frac{d^2y}{dx^2} + 2\frac{dy}{dx} \frac{d^3y}{dx^3} + x = 0$

(b)  $y'' - 3y' + 2y = x^7$

(c)  $y' - y^7 = 0$

(d)  $y''y - (y')^2 = 2$

2. Verify that the function is a solution of the differential equation on some interval, for any choice of the arbitrary constants appearing in the function.

(a)  $y = ce^{2x}; \quad y' = 2y$

(b)  $y = \frac{x^2}{3} + \frac{c}{x}; \quad xy' + y = x^2$

(c)  $y = \frac{1}{2} + ce^{-x^2}; \quad y' + 2xy = x$

(d)  $y = (1 + ce^{-x^2/2}); (1 - ce^{-x^2/2})^{-1} \quad 2y' + x(y^2 - 1) = 0$

(e)  $y = \tan\left(\frac{x^3}{3} + c\right); \quad y' = x^2(1 + y^2)$

(f)  $y = (c_1 + c_2x)e^x + \sin x + x^2; \quad y'' - 2y' + y = -2\cos x + x^2 - 4x + 2$

(g)  $y = c_1e^x + c_2x + \frac{2}{x}; \quad (1 - x)y'' + xy' - y = 4(1 - x - x^2)x^{-3}$

(h)  $y = x^{-1/2}(c_1 \sin x + c_2 \cos x) + 4x + 8;$   
 $x^2y'' + xy' + \left(x^2 - \frac{1}{4}\right)y = 4x^3 + 8x^2 + 3x - 2$

3. Find all solutions of the equation.

(a)  $y' = -x$

(b)  $y' = -x \sin x$

(c)  $y' = x \ln x$

(d)  $y'' = x \cos x$

(e)  $y'' = 2xe^x$

(f)  $y'' = 2x + \sin x + e^x$

(g)  $y''' = -\cos x$

(h)  $y''' = -x^2 + e^x$

(i)  $y''' = 7e^{4x}$

4. Solve the initial value problem.

(a)  $y' = -xe^x, \quad y(0) = 1$

(b)  $y' = x \sin x^2, \quad y\left(\sqrt{\frac{\pi}{2}}\right) = 1$

(c)  $y' = \tan x, \quad y(\pi/4) = 3$

(d)  $y'' = x^4, \quad y(2) = -1, \quad y'(2) = -1$

(e)  $y'' = xe^{2x}, \quad y(0) = 7, \quad y'(0) = 1$

(f)  $y'' = -x \sin x, \quad y(0) = 1, \quad y'(0) = -3$

(g)  $y''' = x^2e^x, \quad y(0) = 1, \quad y'(0) = -2, \quad y''(0) = 3$

(h)  $y''' = 2 + \sin 2x, \quad y(0) = 1, \quad y'(0) = -6, \quad y''(0) = 3$

(i)  $y''' = 2x + 1, \quad y(2) = 1, \quad y'(2) = -4, \quad y''(2) = 7$

5. Verify that the function is a solution of the initial value problem.

(a)  $y = x \cos x; \quad y' = \cos x - y \tan x, \quad y(\pi/4) = \frac{\pi}{4\sqrt{2}}$

(b)  $y = \frac{1 + 2 \ln x}{x^2} + \frac{1}{2}; \quad y' = \frac{x^2 - 2x^2y + 2}{x^3}, \quad y(1) = \frac{3}{2}$

(c)  $y = \tan\left(\frac{x^2}{2}\right); \quad y' = x(1 + y^2), \quad y(0) = 0$

(d)  $y = \frac{2}{x-2}; \quad y' = \frac{-y(y+1)}{x}, \quad y(1) = -2$

6. Verify that the function is a solution of the initial value problem.

(a)  $y = x^2(1 + \ln x); \quad y'' = \frac{3xy' - 4y}{x^2}, \quad y(e) = 2e^2, \quad y'(e) = 5e$

(b)  $y = \frac{x^2}{3} + x - 1; \quad y'' = \frac{x^2 - xy' + y + 1}{x^2}, \quad y(1) = \frac{1}{3}, \quad y'(1) = \frac{5}{3}$

(c)  $y = (1 + x^2)^{-1/2}; \quad y'' = \frac{(x^2 - 1)y - x(x^2 + 1)y'}{(x^2 + 1)^2}, \quad y(0) = 1, \quad y'(0) = 0$

(d)  $y = \frac{x^2}{1-x}; \quad y'' = \frac{2(x+y)(xy' - y)}{x^3}, \quad y(1/2) = 1/2, \quad y'(1/2) = 3$

7. Suppose an object is launched from a point 320 feet above the earth with an initial velocity of 128 ft/sec upward, and the only force acting on it thereafter is gravity. Take  $g = 32$  ft/sec<sup>2</sup>.

(a) Find the highest altitude attained by the object.

(b) Determine how long it takes for the object to fall to the ground.

8. Let  $a$  be a nonzero real number.

(a) Verify that if  $c$  is an arbitrary constant then

$$y = (x - c)^a \tag{A}$$

is a solution of

$$y' = ay^{(a-1)/a} \tag{B}$$

on  $(c, \infty)$ .

(b) Suppose  $a < 0$  or  $a > 1$ . Can you think of a solution of (B) that isn't of the form (A)?

9. Verify that

$$y = \begin{cases} e^x - 1, & x \geq 0, \\ 1 - e^{-x}, & x < 0, \end{cases}$$

is a solution of

$$y' = |y| + 1$$

on  $(-\infty, \infty)$ . HINT: Use the definition of derivative at  $x = 0$ .

10. (a) Verify that if  $c$  is any real number then

$$y = c^2 + cx + 2c + 1 \tag{A}$$

satisfies

$$y' = \frac{-(x+2) + \sqrt{x^2 + 4x + 4y}}{2} \tag{B}$$

on some open interval. Identify the open interval.

(b) Verify that

$$y_1 = \frac{-x(x+4)}{4}$$

also satisfies (B) on some open interval, and identify the open interval. (Note that  $y_1$  can't be obtained by selecting a value of  $c$  in (A).)

### 1.3 DIRECTION FIELDS FOR FIRST ORDER EQUATIONS

It's impossible to find explicit formulas for solutions of some differential equations. Even if there are such formulas, they may be so complicated that they're useless. In this case we may resort to graphical or numerical methods to get some idea of how the solutions of the given equation behave.

In Section 2.3 we'll take up the question of existence of solutions of a first order equation

$$y' = f(x, y). \quad (1.3.1)$$

In this section we'll simply assume that (1.3.1) has solutions and discuss a graphical method for approximating them. In Chapter 3 we discuss numerical methods for obtaining approximate solutions of (1.3.1).

Recall that a solution of (1.3.1) is a function  $y = y(x)$  such that

$$y'(x) = f(x, y(x))$$

for all values of  $x$  in some interval, and an integral curve is either the graph of a solution or is made up of segments that are graphs of solutions. Therefore, not being able to solve (1.3.1) is equivalent to not knowing the equations of integral curves of (1.3.1). However, it's easy to calculate the slopes of these curves. To be specific, the slope of an integral curve of (1.3.1) through a given point  $(x_0, y_0)$  is given by the number  $f(x_0, y_0)$ . This is the basis of *the method of direction fields*.

If  $f$  is defined on a set  $R$ , we can construct a *direction field* for (1.3.1) in  $R$  by drawing a short line segment through each point  $(x, y)$  in  $R$  with slope  $f(x, y)$ . Of course, as a practical matter, we can't actually draw line segments through *every* point in  $R$ ; rather, we must select a finite set of points in  $R$ . For example, suppose  $f$  is defined on the closed rectangular region

$$R : \{a \leq x \leq b, c \leq y \leq d\}.$$

Let

$$a = x_0 < x_1 < \cdots < x_m = b$$

be equally spaced points in  $[a, b]$  and

$$c = y_0 < y_1 < \cdots < y_n = d$$

be equally spaced points in  $[c, d]$ . We say that the points

$$(x_i, y_j), \quad 0 \leq i \leq m, \quad 0 \leq j \leq n,$$

form a *rectangular grid* (Figure 1.3.1). Through each point in the grid we draw a short line segment with slope  $f(x_i, y_j)$ . The result is an approximation to a direction field for (1.3.1) in  $R$ . If the grid points are sufficiently numerous and close together, we can draw approximate integral curves of (1.3.1) by drawing curves through points in the grid tangent to the line segments associated with the points in the grid.

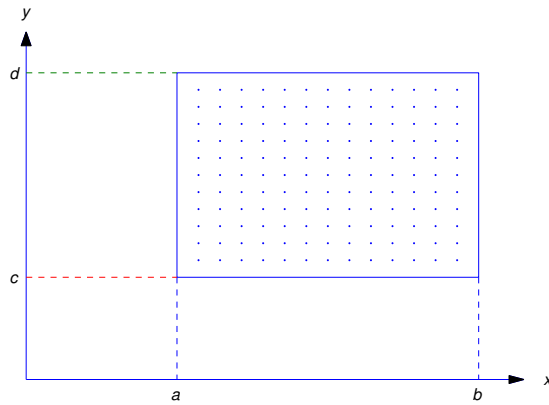

Figure 1.3.1 A rectangular grid

Unfortunately, approximating a direction field and graphing integral curves in this way is too tedious to be done effectively by hand. However, there is software for doing this. As you'll see, the combination of direction fields and integral curves gives useful insights into the behavior of the solutions of the differential equation even if we can't obtain exact solutions.

We'll study numerical methods for solving a single first order equation (1.3.1) in Chapter 3. These methods can be used to plot solution curves of (1.3.1) in a rectangular region  $R$  if  $f$  is continuous on  $R$ . Figures 1.3.2, 1.3.3, and 1.3.4 show direction fields and solution curves for the differential equations

$$y' = \frac{x^2 - y^2}{1 + x^2 + y^2}, \quad y' = 1 + xy^2, \quad \text{and} \quad y' = \frac{x - y}{1 + x^2},$$

which are all of the form (1.3.1) with  $f$  continuous for all  $(x, y)$ .

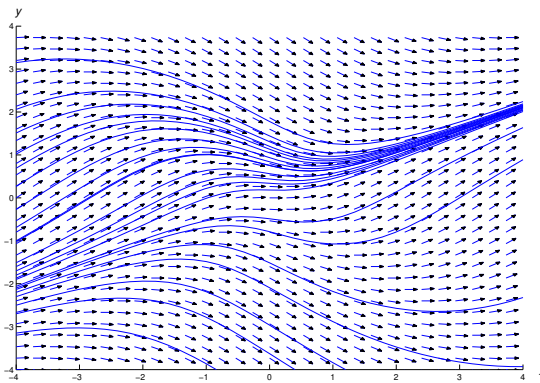

Figure 1.3.2 A direction field and integral curves

$$\text{for } y' = \frac{x^2 - y^2}{1 + x^2 + y^2}$$

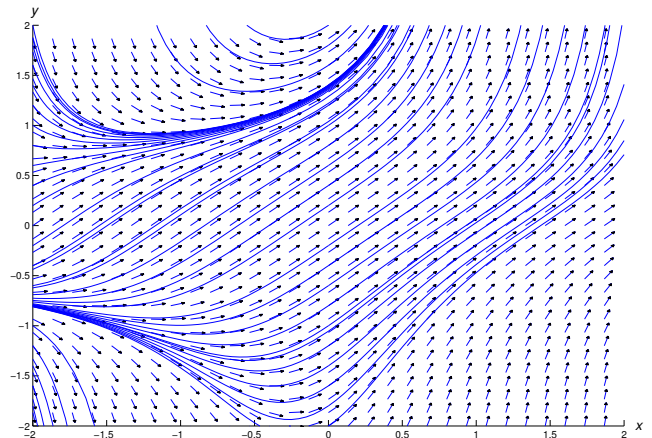

Figure 1.3.3 A direction field and integral curves for

$$y' = 1 + xy^2$$

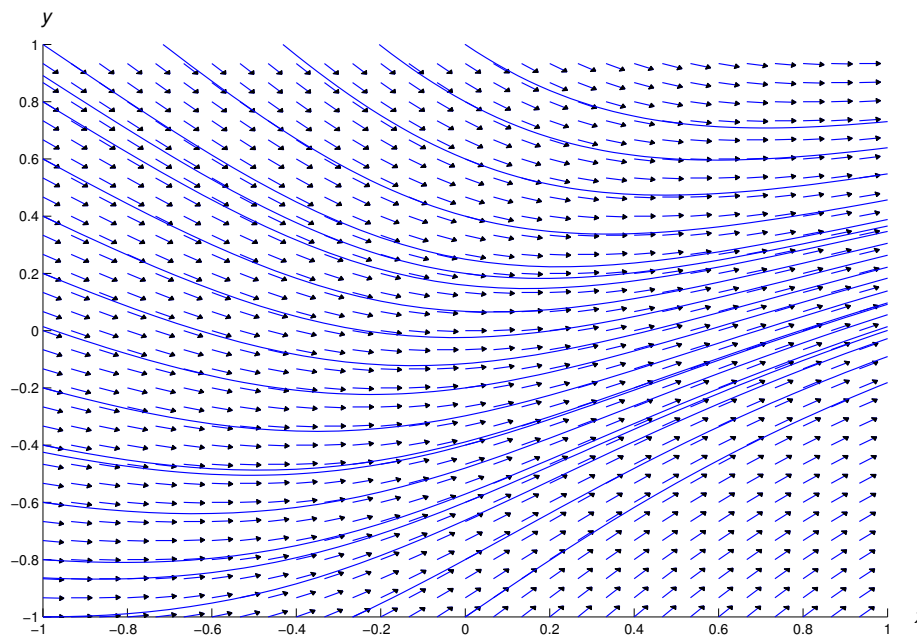

Figure 1.3.4 A direction and integral curves for  $y' = \frac{x - y}{1 + x^2}$

The methods of Chapter 3 won't work for the equation

$$y' = -x/y \quad (1.3.2)$$

if  $R$  contains part of the  $x$ -axis, since  $f(x, y) = -x/y$  is undefined when  $y = 0$ . Similarly, they won't work for the equation

$$y' = \frac{x^2}{1 - x^2 - y^2} \quad (1.3.3)$$

if  $R$  contains any part of the unit circle  $x^2 + y^2 = 1$ , because the right side of (1.3.3) is undefined if  $x^2 + y^2 = 1$ . However, (1.3.2) and (1.3.3) can be written as

$$y' = \frac{A(x, y)}{B(x, y)} \quad (1.3.4)$$

where  $A$  and  $B$  are continuous on any rectangle  $R$ . Because of this, some differential equation software is based on numerically solving pairs of equations of the form

$$\frac{dx}{dt} = B(x, y), \quad \frac{dy}{dt} = A(x, y) \quad (1.3.5)$$

where  $x$  and  $y$  are regarded as functions of a parameter  $t$ . If  $x = x(t)$  and  $y = y(t)$  satisfy these equations, then

$$y' = \frac{dy}{dx} = \frac{dy}{dt} \bigg/ \frac{dx}{dt} = \frac{A(x, y)}{B(x, y)},$$

so  $y = y(x)$  satisfies (1.3.4).



Eqns. (1.3.2) and (1.3.3) can be reformulated as in (1.3.4) with

$$\frac{dx}{dt} = -y, \quad \frac{dy}{dt} = x$$

and

$$\frac{dx}{dt} = 1 - x^2 - y^2, \quad \frac{dy}{dt} = x^2,$$

respectively. Even if  $f$  is continuous and otherwise “nice” throughout  $R$ , your software may require you to reformulate the equation  $y' = f(x, y)$  as

$$\frac{dx}{dt} = 1, \quad \frac{dy}{dt} = f(x, y),$$

which is of the form (1.3.5) with  $A(x, y) = f(x, y)$  and  $B(x, y) = 1$ .

Figure 1.3.5 shows a direction field and some integral curves for (1.3.2). As we saw in Example 1.2.1 and will verify again in Section 2.2, the integral curves of (1.3.2) are circles centered at the origin.

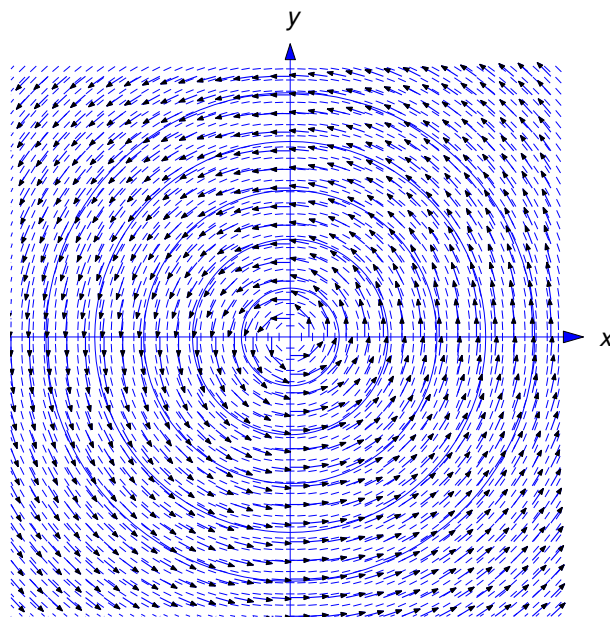

Figure 1.3.5 A direction field and integral curves for  $y' = -\frac{x}{y}$

Figure 1.3.6 shows a direction field and some integral curves for (1.3.3). The integral curves near the top and bottom are solution curves. However, the integral curves near the middle are more complicated. For example, Figure 1.3.7 shows the integral curve through the origin. The vertices of the dashed rectangle are on the circle  $x^2 + y^2 = 1$  ( $a \approx .846$ ,  $b \approx .533$ ), where all integral curves of (1.3.3) have infinite slope. There are three solution curves of (1.3.3) on the integral curve in the figure: the segment above the level  $y = b$  is the graph of a solution on  $(-\infty, a)$ , the segment below the level  $y = -b$  is the graph of a solution on  $(-a, \infty)$ , and the segment between these two levels is the graph of a solution on  $(-a, a)$ .

**USING TECHNOLOGY**

As you study from this book, you'll often be asked to use computer software and graphics. Exercises with this intent are marked as **C** (computer or calculator required), **C/G** (computer and/or graphics required), or **L** (laboratory work requiring software and/or graphics). Often you may not completely understand how the software does what it does. This is similar to the situation most people are in when they drive automobiles or watch television, and it doesn't decrease the value of using modern technology as an aid to learning. Just be careful that you use the technology as a supplement to thought rather than a substitute for it.

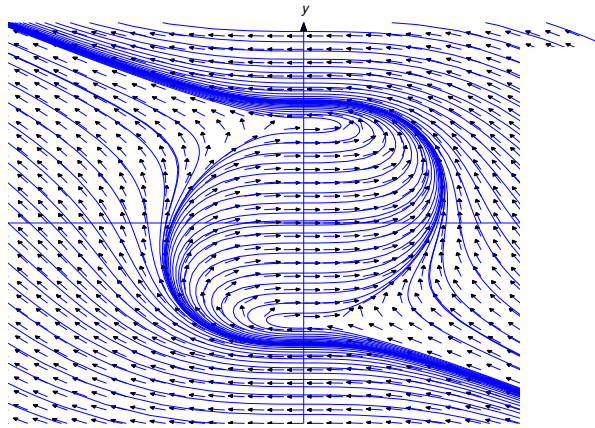

Figure 1.3.6 A direction field and integral curves for

$$y' = \frac{x^2}{1 - x^2 - y^2}$$

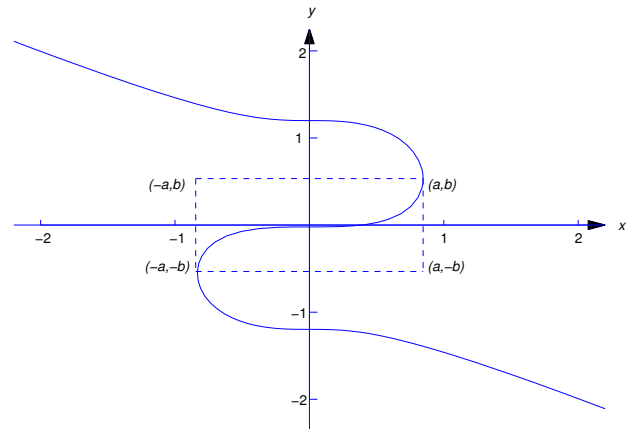
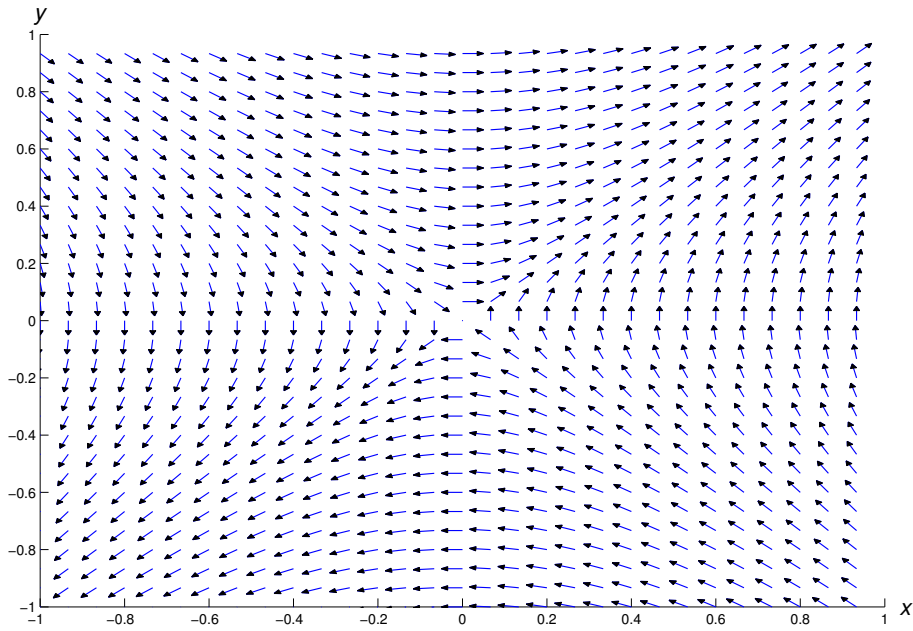

Figure 1.3.7

### 1.3 Exercises

In Exercises 1–11 a direction field is drawn for the given equation. Sketch some integral curves.



1 A direction field for  $y' = \frac{x}{y}$

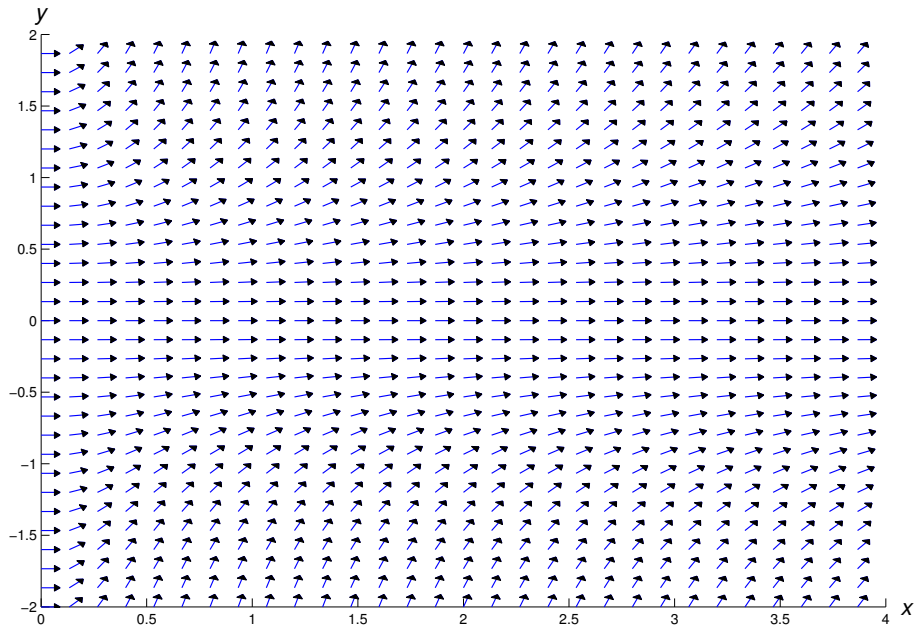

2 A direction field for  $y' = \frac{2xy^2}{1+x^2}$

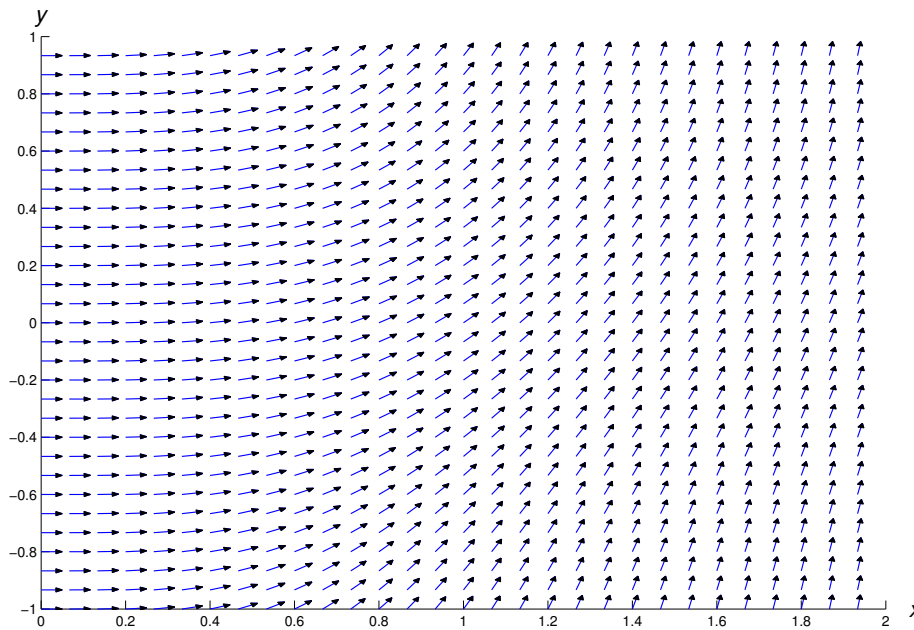

3 A direction field for  $y' = x^2(1+y^2)$

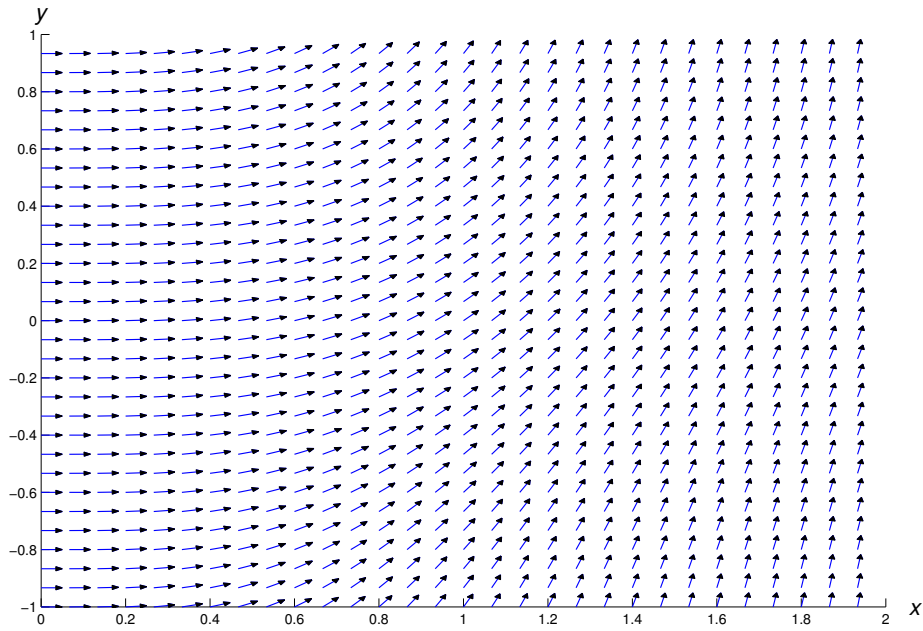

4 A direction field for  $y' = \frac{1}{1+x^2+y^2}$

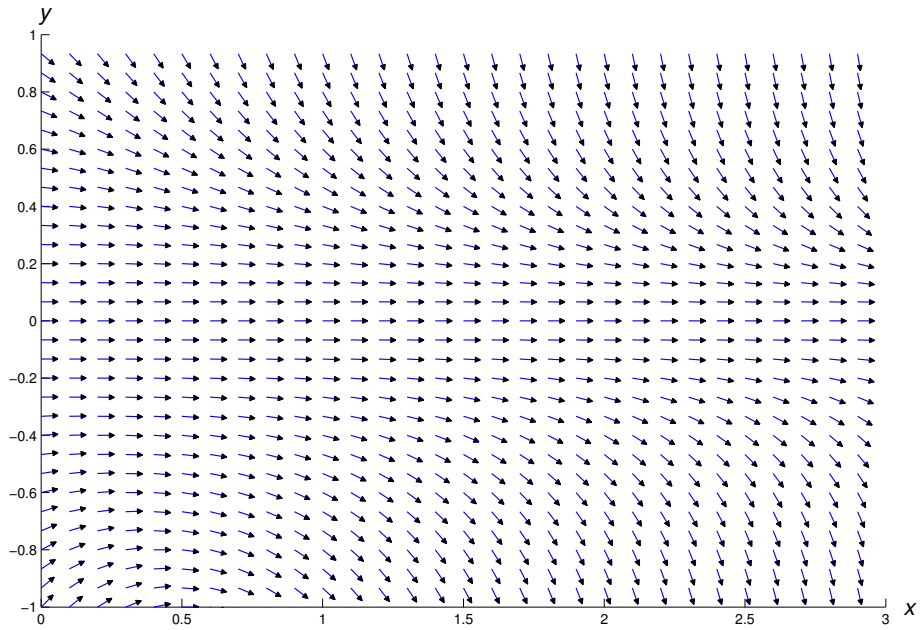

5 A direction field for  $y' = -(2xy^2 + y^3)$

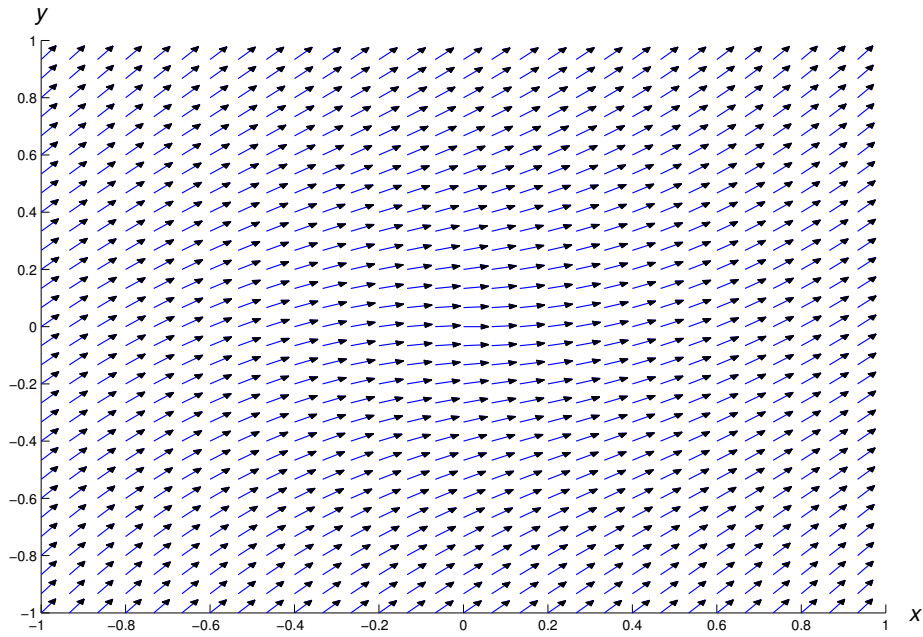

6 A direction field for  $y' = (x^2 + y^2)^{1/2}$

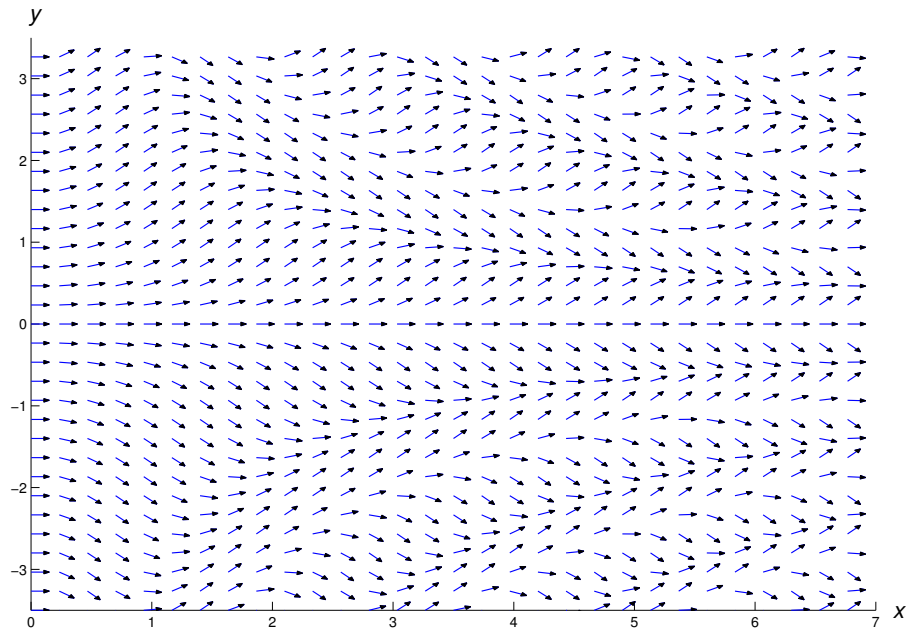

7 A direction field for  $y' = \sin xy$

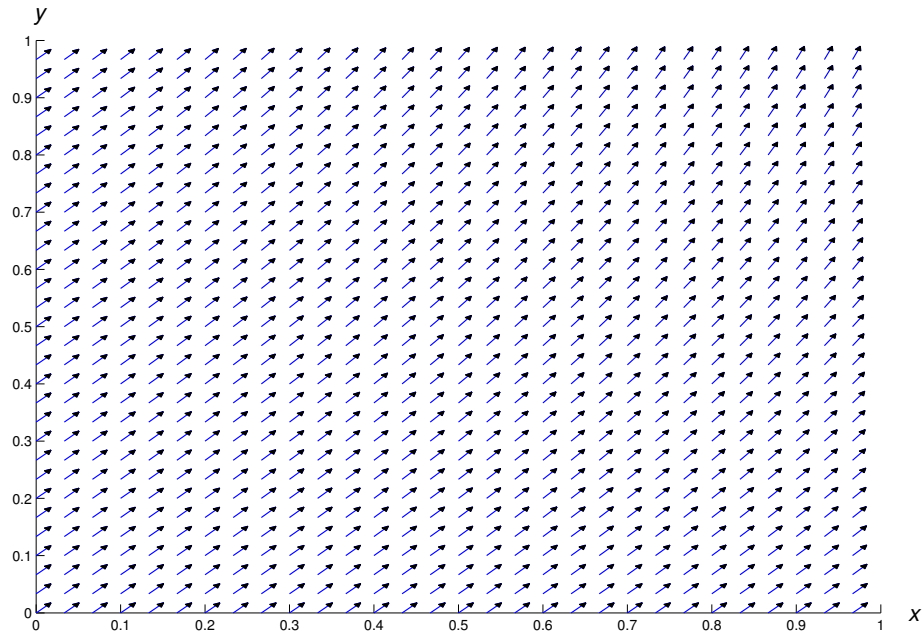

8 A direction field for  $y' = e^{xy}$

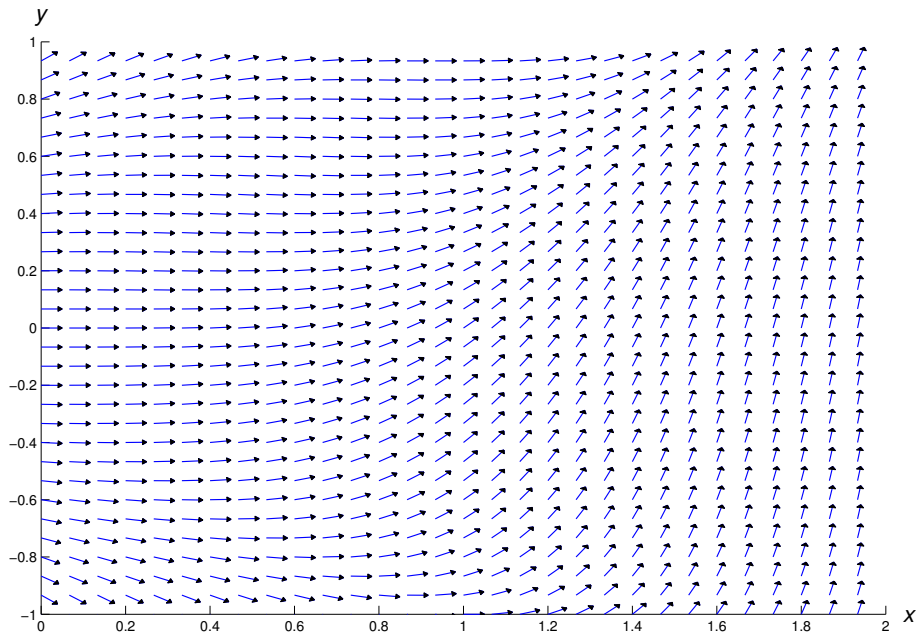

9 A direction field for  $y' = (x - y^2)(x^2 - y)$

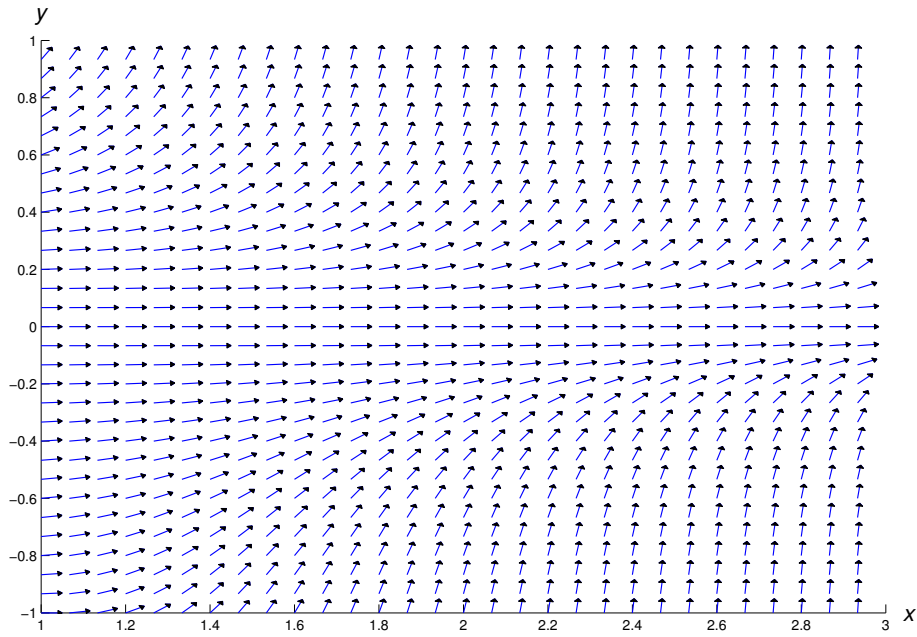

**10** A direction field for  $y' = x^3 y^2 + x y^3$

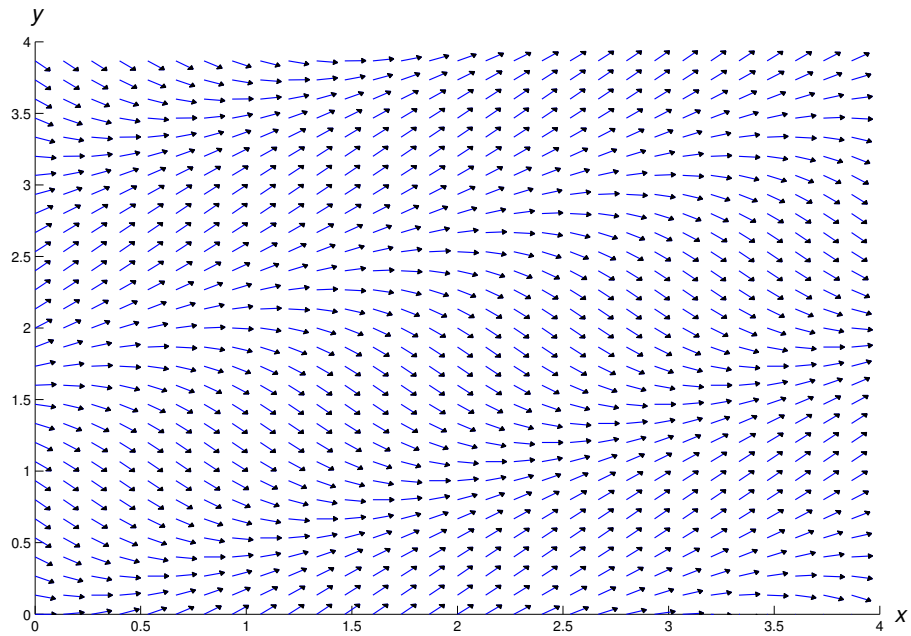

**11** A direction field for  $y' = \sin(x - 2y)$



In Exercises 12-22 construct a direction field and plot some integral curves in the indicated rectangular region.

12. C/G  $y' = y(y - 1); \quad \{-1 \leq x \leq 2, -2 \leq y \leq 2\}$

13. C/G  $y' = 2 - 3xy; \quad \{-1 \leq x \leq 4, -4 \leq y \leq 4\}$

14. C/G  $y' = xy(y - 1); \quad \{-2 \leq x \leq 2, -4 \leq y \leq 4\}$

15. C/G  $y' = 3x + y; \quad \{-2 \leq x \leq 2, 0 \leq y \leq 4\}$

16. C/G  $y' = y - x^3; \quad \{-2 \leq x \leq 2, -2 \leq y \leq 2\}$

17. C/G  $y' = 1 - x^2 - y^2; \quad \{-2 \leq x \leq 2, -2 \leq y \leq 2\}$

18. C/G  $y' = x(y^2 - 1); \quad \{-3 \leq x \leq 3, -3 \leq y \leq 2\}$

19. C/G  $y' = \frac{x}{y(y^2 - 1)}; \quad \{-2 \leq x \leq 2, -2 \leq y \leq 2\}$

20. C/G  $y' = \frac{xy^2}{y - 1}; \quad \{-2 \leq x \leq 2, -1 \leq y \leq 4\}$

21. C/G  $y' = \frac{x(y^2 - 1)}{y}; \quad \{-1 \leq x \leq 1, -2 \leq y \leq 2\}$

22. C/G  $y' = -\frac{x^2 + y^2}{1 - x^2 - y^2}; \quad \{-2 \leq x \leq 2, -2 \leq y \leq 2\}$

23. L By suitably renaming the constants and dependent variables in the equations

$$T' = -k(T - T_m) \quad (\text{A})$$

and

$$G' = -\lambda G + r \quad (\text{B})$$

discussed in Section 1.2 in connection with Newton's law of cooling and absorption of glucose in the body, we can write both as

$$y' = -ay + b, \quad (\text{C})$$

where  $a$  is a positive constant and  $b$  is an arbitrary constant. Thus, (A) is of the form (C) with  $y = T$ ,  $a = k$ , and  $b = kT_m$ , and (B) is of the form (C) with  $y = G$ ,  $a = \lambda$ , and  $b = r$ . We'll encounter equations of the form (C) in many other applications in Chapter 2.

Choose a positive  $a$  and an arbitrary  $b$ . Construct a direction field and plot some integral curves for (C) in a rectangular region of the form

$$\{0 \leq t \leq T, c \leq y \leq d\}$$

of the  $ty$ -plane. Vary  $T$ ,  $c$ , and  $d$  until you discover a common property of all the solutions of (C). Repeat this experiment with various choices of  $a$  and  $b$  until you can state this property precisely in terms of  $a$  and  $b$ .

24. L By suitably renaming the constants and dependent variables in the equations

$$P' = aP(1 - \alpha P) \quad (\text{A})$$

and

$$I' = rI(S - I) \quad (\text{B})$$

discussed in Section 1.1 in connection with Verhulst's population model and the spread of an epidemic, we can write both in the form

$$y' = ay - by^2, \quad (\text{C})$$

where  $a$  and  $b$  are positive constants. Thus, (A) is of the form (C) with  $y = P$ ,  $a = a$ , and  $b = a\alpha$ , and (B) is of the form (C) with  $y = I$ ,  $a = rS$ , and  $b = r$ . In Chapter 2 we'll encounter equations of the form (C) in other applications..

- (a) Choose positive numbers  $a$  and  $b$ . Construct a direction field and plot some integral curves for (C) in a rectangular region of the form

$$\{0 \leq t \leq T, 0 \leq y \leq d\}$$

of the  $ty$ -plane. Vary  $T$  and  $d$  until you discover a common property of all solutions of (C) with  $y(0) > 0$ . Repeat this experiment with various choices of  $a$  and  $b$  until you can state this property precisely in terms of  $a$  and  $b$ .

- (b) Choose positive numbers  $a$  and  $b$ . Construct a direction field and plot some integral curves for (C) in a rectangular region of the form

$$\{0 \leq t \leq T, c \leq y \leq 0\}$$

of the  $ty$ -plane. Vary  $a$ ,  $b$ ,  $T$  and  $c$  until you discover a common property of all solutions of (C) with  $y(0) < 0$ .

You can verify your results later by doing Exercise 2.2.27.

# CHAPTER 2

## First Order Equations

IN THIS CHAPTER we study first order equations for which there are general methods of solution.

SECTION 2.1 deals with linear equations, the simplest kind of first order equations. In this section we introduce the method of variation of parameters. The idea underlying this method will be a unifying theme for our approach to solving many different kinds of differential equations throughout the book.

SECTION 2.2 deals with separable equations, the simplest nonlinear equations. In this section we introduce the idea of implicit and constant solutions of differential equations, and we point out some differences between the properties of linear and nonlinear equations.

SECTION 2.3 discusses existence and uniqueness of solutions of nonlinear equations. Although it may seem logical to place this section before Section 2.2, we presented Section 2.2 first so we could have illustrative examples in Section 2.3.

SECTION 2.4 deals with nonlinear equations that are not separable, but can be transformed into separable equations by a procedure similar to variation of parameters.

SECTION 2.5 covers exact differential equations, which are given this name because the method for solving them uses the idea of an exact differential from calculus.

SECTION 2.6 deals with equations that are not exact, but can be made exact by multiplying them by a function known called *integrating factor*.

**2.1 LINEAR FIRST ORDER EQUATIONS**

A first order differential equation is said to be *linear* if it can be written as

$$y' + p(x)y = f(x). \quad (2.1.1)$$

A first order differential equation that can't be written like this is *nonlinear*. We say that (2.1.1) is *homogeneous* if  $f \equiv 0$ ; otherwise it's *nonhomogeneous*. Since  $y \equiv 0$  is obviously a solution of the homogeneous equation

$$y' + p(x)y = 0,$$

we call it the *trivial solution*. Any other solution is *nontrivial*.

**Example 2.1.1** The first order equations

$$\begin{aligned} x^2y' + 3y &= x^2, \\ xy' - 8x^2y &= \sin x, \\ xy' + (\ln x)y &= 0, \\ y' &= x^2y - 2, \end{aligned}$$

are not in the form (2.1.1), but they are linear, since they can be rewritten as

$$\begin{aligned} y' + \frac{3}{x^2}y &= 1, \\ y' - 8xy &= \frac{\sin x}{x}, \\ y' + \frac{\ln x}{x}y &= 0, \\ y' - x^2y &= -2. \end{aligned}$$

**Example 2.1.2** Here are some nonlinear first order equations:

$$\begin{aligned} xy' + 3y^2 &= 2x && \text{(because } y \text{ is squared),} \\ yy' &= 3 && \text{(because of the product } yy'), \\ y' + xe^y &= 12 && \text{(because of } e^y). \end{aligned}$$

**General Solution of a Linear First Order Equation**

To motivate a definition that we'll need, consider the simple linear first order equation

$$y' = \frac{1}{x^2}. \quad (2.1.2)$$

From calculus we know that  $y$  satisfies this equation if and only if

$$y = -\frac{1}{x} + c, \quad (2.1.3)$$

where  $c$  is an arbitrary constant. We call  $c$  a *parameter* and say that (2.1.3) defines a *one-parameter family* of functions. For each real number  $c$ , the function defined by (2.1.3) is a solution of (2.1.2) on

$(-\infty, 0)$  and  $(0, \infty)$ ; moreover, every solution of (2.1.2) on either of these intervals is of the form (2.1.3) for some choice of  $c$ . We say that (2.1.3) is *the general solution* of (2.1.2).

We'll see that a similar situation occurs in connection with any first order linear equation

$$y' + p(x)y = f(x); \quad (2.1.4)$$

that is, if  $p$  and  $f$  are continuous on some open interval  $(a, b)$  then there's a unique formula  $y = y(x, c)$  analogous to (2.1.3) that involves  $x$  and a parameter  $c$  and has the these properties:

- For each fixed value of  $c$ , the resulting function of  $x$  is a solution of (2.1.4) on  $(a, b)$ .
- If  $y$  is a solution of (2.1.4) on  $(a, b)$ , then  $y$  can be obtained from the formula by choosing  $c$  appropriately.

We'll call  $y = y(x, c)$  the *general solution* of (2.1.4).

When this has been established, it will follow that an equation of the form

$$P_0(x)y' + P_1(x)y = F(x) \quad (2.1.5)$$

has a general solution on any open interval  $(a, b)$  on which  $P_0$ ,  $P_1$ , and  $F$  are all continuous and  $P_0$  has no zeros, since in this case we can rewrite (2.1.5) in the form (2.1.4) with  $p = P_1/P_0$  and  $f = F/P_0$ , which are both continuous on  $(a, b)$ .

To avoid awkward wording in examples and exercises, we won't specify the interval  $(a, b)$  when we ask for the general solution of a specific linear first order equation. Let's agree that this always means that we want the general solution on every open interval on which  $p$  and  $f$  are continuous if the equation is of the form (2.1.4), or on which  $P_0$ ,  $P_1$ , and  $F$  are continuous and  $P_0$  has no zeros, if the equation is of the form (2.1.5). We leave it to you to identify these intervals in specific examples and exercises.

For completeness, we point out that if  $P_0$ ,  $P_1$ , and  $F$  are all continuous on an open interval  $(a, b)$ , but  $P_0$  *does* have a zero in  $(a, b)$ , then (2.1.5) may fail to have a general solution on  $(a, b)$  in the sense just defined. Since this isn't a major point that needs to be developed in depth, we won't discuss it further; however, see Exercise 44 for an example.

### Homogeneous Linear First Order Equations

We begin with the problem of finding the general solution of a homogeneous linear first order equation. The next example recalls a familiar result from calculus.

**Example 2.1.3** Let  $a$  be a constant.

(a) Find the general solution of

$$y' - ay = 0. \quad (2.1.6)$$

(b) Solve the initial value problem

$$y' - ay = 0, \quad y(x_0) = y_0.$$

**SOLUTION(a)** You already know from calculus that if  $c$  is any constant, then  $y = ce^{ax}$  satisfies (2.1.6). However, let's pretend you've forgotten this, and use this problem to illustrate a general method for solving a homogeneous linear first order equation.

We know that (2.1.6) has the trivial solution  $y \equiv 0$ . Now suppose  $y$  is a nontrivial solution of (2.1.6). Then, since a differentiable function must be continuous, there must be some open interval  $I$  on which  $y$  has no zeros. We rewrite (2.1.6) as

$$\frac{y'}{y} = a$$

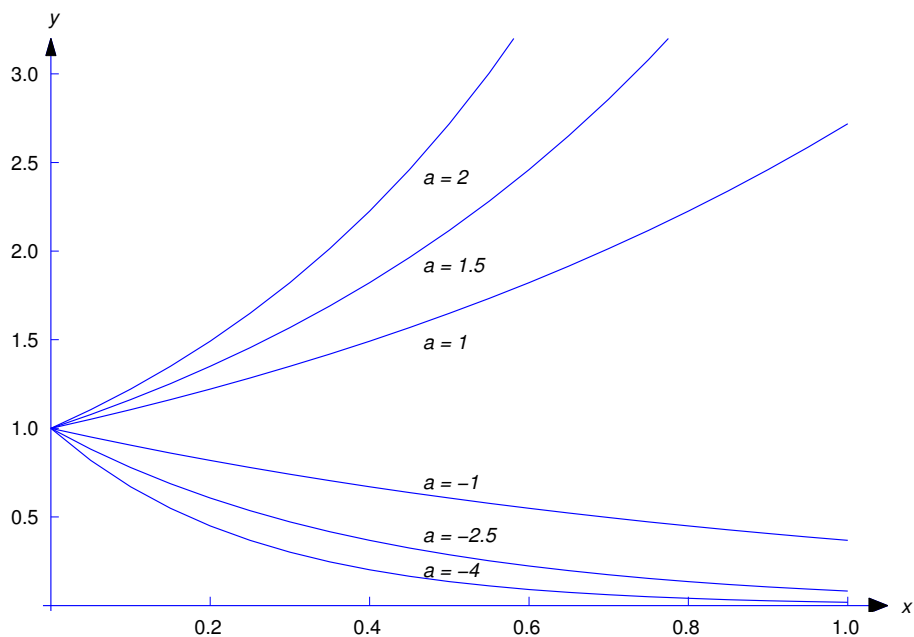
Figure 2.1.1 Solutions of  $y' - ay = 0$ ,  $y(0) = 1$ 

for  $x$  in  $I$ . Integrating this shows that

$$\ln |y| = ax + k, \quad \text{so} \quad |y| = e^k e^{ax},$$

where  $k$  is an arbitrary constant. Since  $e^{ax}$  can never equal zero,  $y$  has no zeros, so  $y$  is either always positive or always negative. Therefore we can rewrite  $y$  as

$$y = ce^{ax} \tag{2.1.7}$$

where

$$c = \begin{cases} e^k & \text{if } y > 0, \\ -e^k & \text{if } y < 0. \end{cases}$$

This shows that every nontrivial solution of (2.1.6) is of the form  $y = ce^{ax}$  for some nonzero constant  $c$ . Since setting  $c = 0$  yields the trivial solution, *all* solutions of (2.1.6) are of the form (2.1.7). Conversely, (2.1.7) is a solution of (2.1.6) for every choice of  $c$ , since differentiating (2.1.7) yields  $y' = ace^{ax} = ay$ .

**SOLUTION(b)** Imposing the initial condition  $y(x_0) = y_0$  yields  $y_0 = ce^{ax_0}$ , so  $c = y_0 e^{-ax_0}$  and

$$y = y_0 e^{-ax_0} e^{ax} = y_0 e^{a(x-x_0)}.$$

Figure 2.1.1 show the graphs of this function with  $x_0 = 0$ ,  $y_0 = 1$ , and various values of  $a$ .

**Example 2.1.4 (a)** Find the general solution of

$$xy' + y = 0. \tag{2.1.8}$$

**(b)** Solve the initial value problem

$$xy' + y = 0, \quad y(1) = 3. \tag{2.1.9}$$

**SOLUTION(a)** We rewrite (2.1.8) as

$$y' + \frac{1}{x}y = 0, \quad (2.1.10)$$

where  $x$  is restricted to either  $(-\infty, 0)$  or  $(0, \infty)$ . If  $y$  is a nontrivial solution of (2.1.10), there must be some open interval  $I$  on which  $y$  has no zeros. We can rewrite (2.1.10) as

$$\frac{y'}{y} = -\frac{1}{x}$$

for  $x$  in  $I$ . Integrating shows that

$$\ln |y| = -\ln |x| + k, \quad \text{so} \quad |y| = \frac{e^k}{|x|}.$$

Since a function that satisfies the last equation can't change sign on either  $(-\infty, 0)$  or  $(0, \infty)$ , we can rewrite this result more simply as

$$y = \frac{c}{x} \quad (2.1.11)$$

where

$$c = \begin{cases} e^k & \text{if } y > 0, \\ -e^k & \text{if } y < 0. \end{cases}$$

We've now shown that every solution of (2.1.10) is given by (2.1.11) for some choice of  $c$ . (Even though we assumed that  $y$  was nontrivial to derive (2.1.11), we can get the trivial solution by setting  $c = 0$  in (2.1.11).) Conversely, any function of the form (2.1.11) is a solution of (2.1.10), since differentiating (2.1.11) yields

$$y' = -\frac{c}{x^2},$$

and substituting this and (2.1.11) into (2.1.10) yields

$$\begin{aligned} y' + \frac{1}{x}y &= -\frac{c}{x^2} + \frac{1}{x} \frac{c}{x} \\ &= -\frac{c}{x^2} + \frac{c}{x^2} = 0. \end{aligned}$$

Figure 2.1.2 shows the graphs of some solutions corresponding to various values of  $c$

**SOLUTION(b)** Imposing the initial condition  $y(1) = 3$  in (2.1.11) yields  $c = 3$ . Therefore the solution of (2.1.9) is

$$y = \frac{3}{x}.$$

The interval of validity of this solution is  $(0, \infty)$ .

The results in Examples 2.1.3(a) and 2.1.4(b) are special cases of the next theorem.

**Theorem 2.1.1** *If  $p$  is continuous on  $(a, b)$ , then the general solution of the homogeneous equation*

$$y' + p(x)y = 0 \quad (2.1.12)$$

*on  $(a, b)$  is*

$$y = ce^{-P(x)},$$

*where*

$$P(x) = \int p(x) dx \quad (2.1.13)$$

*is any antiderivative of  $p$  on  $(a, b)$ ; that is,*

$$P'(x) = p(x), \quad a < x < b. \quad (2.1.14)$$

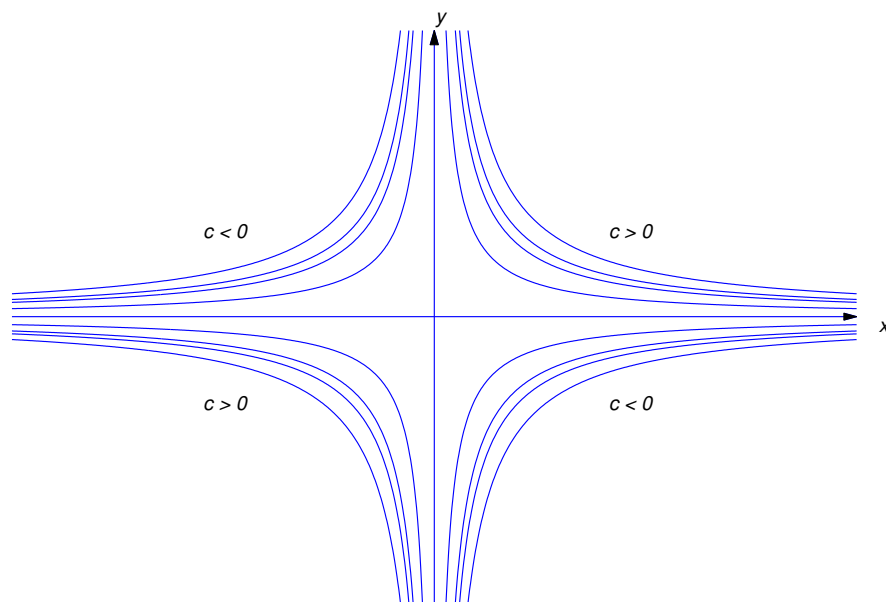
Figure 2.1.2 Solutions of  $xy' + y = 0$  on  $(0, \infty)$  and  $(-\infty, 0)$ 

**Proof** If  $y = ce^{-P(x)}$ , differentiating  $y$  and using (2.1.14) shows that

$$y' = -P'(x)ce^{-P(x)} = -p(x)ce^{-P(x)} = -p(x)y,$$

so  $y' + p(x)y = 0$ ; that is,  $y$  is a solution of (2.1.12), for any choice of  $c$ .

Now we'll show that any solution of (2.1.12) can be written as  $y = ce^{-P(x)}$  for some constant  $c$ . The trivial solution can be written this way, with  $c = 0$ . Now suppose  $y$  is a nontrivial solution. Then there's an open subinterval  $I$  of  $(a, b)$  on which  $y$  has no zeros. We can rewrite (2.1.12) as

$$\frac{y'}{y} = -p(x) \tag{2.1.15}$$

for  $x$  in  $I$ . Integrating (2.1.15) and recalling (2.1.13) yields

$$\ln |y| = -P(x) + k,$$

where  $k$  is a constant. This implies that

$$|y| = e^k e^{-P(x)}.$$

Since  $P$  is defined for all  $x$  in  $(a, b)$  and an exponential can never equal zero, we can take  $I = (a, b)$ , so  $y$  has zeros on  $(a, b)$ , so we can rewrite the last equation as  $y = ce^{-P(x)}$ , where

$$c = \begin{cases} e^k & \text{if } y > 0 \text{ on } (a, b), \\ -e^k & \text{if } y < 0 \text{ on } (a, b). \end{cases}$$

**REMARK:** Rewriting a first order differential equation so that one side depends only on  $y$  and  $y'$  and the other depends only on  $x$  is called *separation of variables*. We did this in Examples 2.1.3 and 2.1.4, and in rewriting (2.1.12) as (2.1.15). We'll apply this method to nonlinear equations in Section 2.2.



**Linear Nonhomogeneous First Order Equations**

We'll now solve the nonhomogeneous equation

$$y' + p(x)y = f(x). \quad (2.1.16)$$

When considering this equation we call

$$y' + p(x)y = 0$$

the *complementary equation*.

We'll find solutions of (2.1.16) in the form  $y = uy_1$ , where  $y_1$  is a nontrivial solution of the complementary equation and  $u$  is to be determined. This method of using a solution of the complementary equation to obtain solutions of a nonhomogeneous equation is a special case of a method called *variation of parameters*, which you'll encounter several times in this book. (Obviously,  $u$  can't be constant, since if it were, the left side of (2.1.16) would be zero. Recognizing this, the early users of this method viewed  $u$  as a "parameter" that varies; hence, the name "variation of parameters.")

If

$$y = uy_1, \quad \text{then} \quad y' = u'y_1 + uy_1'.$$

Substituting these expressions for  $y$  and  $y'$  into (2.1.16) yields

$$u'y_1 + u(y_1' + p(x)y_1) = f(x),$$

which reduces to

$$u'y_1 = f(x), \quad (2.1.17)$$

since  $y_1$  is a solution of the complementary equation; that is,

$$y_1' + p(x)y_1 = 0.$$

In the proof of Theorem 2.2.1 we saw that  $y_1$  has no zeros on an interval where  $p$  is continuous. Therefore we can divide (2.1.17) through by  $y_1$  to obtain

$$u' = f(x)/y_1(x).$$

We can integrate this (introducing a constant of integration), and multiply the result by  $y_1$  to get the general solution of (2.1.16). Before turning to the formal proof of this claim, let's consider some examples.

**Example 2.1.5** Find the general solution of

$$y' + 2y = x^3e^{-2x}. \quad (2.1.18)$$

By applying (a) of Example 2.1.3 with  $a = -2$ , we see that  $y_1 = e^{-2x}$  is a solution of the complementary equation  $y' + 2y = 0$ . Therefore we seek solutions of (2.1.18) in the form  $y = ue^{-2x}$ , so that

$$y' = u'e^{-2x} - 2ue^{-2x} \quad \text{and} \quad y' + 2y = u'e^{-2x} - 2ue^{-2x} + 2ue^{-2x} = u'e^{-2x}. \quad (2.1.19)$$

Therefore  $y$  is a solution of (2.1.18) if and only if

$$u'e^{-2x} = x^3e^{-2x} \quad \text{or, equivalently,} \quad u' = x^3.$$

Therefore

$$u = \frac{x^4}{4} + c,$$

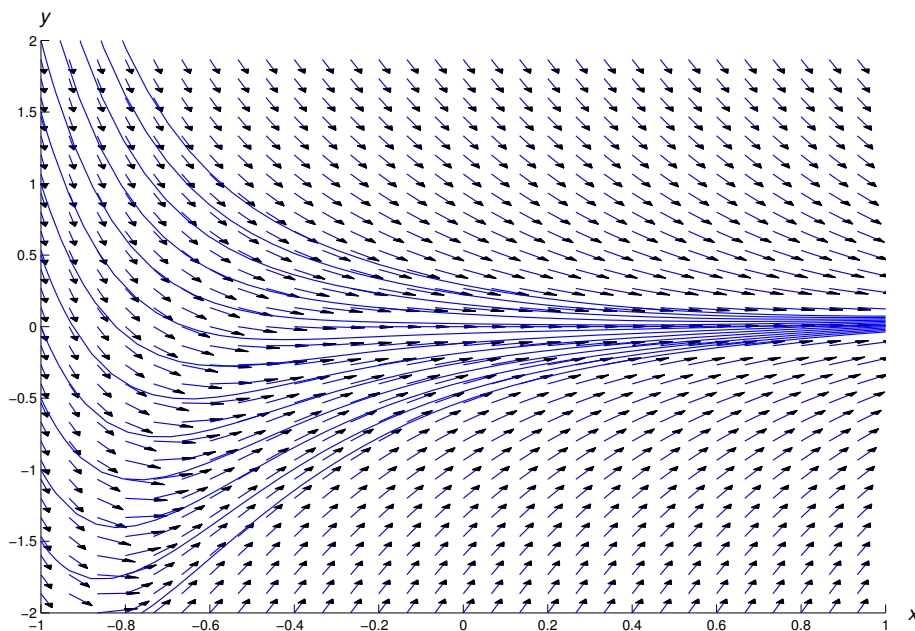

Figure 2.1.3 A direction field and integral curves for  $y' + 2y = x^2 e^{-2x}$

and

$$y = ue^{-2x} = e^{-2x} \left( \frac{x^4}{4} + c \right)$$

is the general solution of (2.1.18).

Figure 2.1.3 shows a direction field and some integral curves for (2.1.18).

### Example 2.1.6

(a) Find the general solution

$$y' + (\cot x)y = x \csc x. \quad (2.1.20)$$

(b) Solve the initial value problem

$$y' + (\cot x)y = x \csc x, \quad y(\pi/2) = 1. \quad (2.1.21)$$

**SOLUTION(a)** Here  $p(x) = \cot x$  and  $f(x) = x \csc x$  are both continuous except at the points  $x = r\pi$ , where  $r$  is an integer. Therefore we seek solutions of (2.1.20) on the intervals  $(r\pi, (r+1)\pi)$ . We need a nontrivial solution  $y_1$  of the complementary equation; thus,  $y_1$  must satisfy  $y_1' + (\cot x)y_1 = 0$ , which we rewrite as

$$\frac{y_1'}{y_1} = -\cot x = -\frac{\cos x}{\sin x}. \quad (2.1.22)$$

Integrating this yields

$$\ln |y_1| = -\ln |\sin x|,$$

where we take the constant of integration to be zero since we need only *one* function that satisfies (2.1.22). Clearly  $y_1 = 1/\sin x$  is a suitable choice. Therefore we seek solutions of (2.1.20) in the form

$$y = \frac{u}{\sin x},$$

so that

$$y' = \frac{u'}{\sin x} - \frac{u \cos x}{\sin^2 x} \quad (2.1.23)$$

and

$$\begin{aligned} y' + (\cot x)y &= \frac{u'}{\sin x} - \frac{u \cos x}{\sin^2 x} + \frac{u \cot x}{\sin x} \\ &= \frac{u'}{\sin x} - \frac{u \cos x}{\sin^2 x} + \frac{u \cos x}{\sin^2 x} \\ &= \frac{u'}{\sin x}. \end{aligned} \quad (2.1.24)$$

Therefore  $y$  is a solution of (2.1.20) if and only if

$$u' / \sin x = x \csc x = x / \sin x \quad \text{or, equivalently,} \quad u' = x.$$

Integrating this yields

$$u = \frac{x^2}{2} + c, \quad \text{and} \quad y = \frac{u}{\sin x} = \frac{x^2}{2 \sin x} + \frac{c}{\sin x}. \quad (2.1.25)$$

is the general solution of (2.1.20) on every interval  $(r\pi, (r+1)\pi)$  ( $r = \text{integer}$ ).

**SOLUTION(b)** Imposing the initial condition  $y(\pi/2) = 1$  in (2.1.25) yields

$$1 = \frac{\pi^2}{8} + c \quad \text{or} \quad c = 1 - \frac{\pi^2}{8}.$$

Thus,

$$y = \frac{x^2}{2 \sin x} + \frac{(1 - \pi^2/8)}{\sin x}$$

is a solution of (2.1.21). The interval of validity of this solution is  $(0, \pi)$ ; Figure 2.1.4 shows its graph.

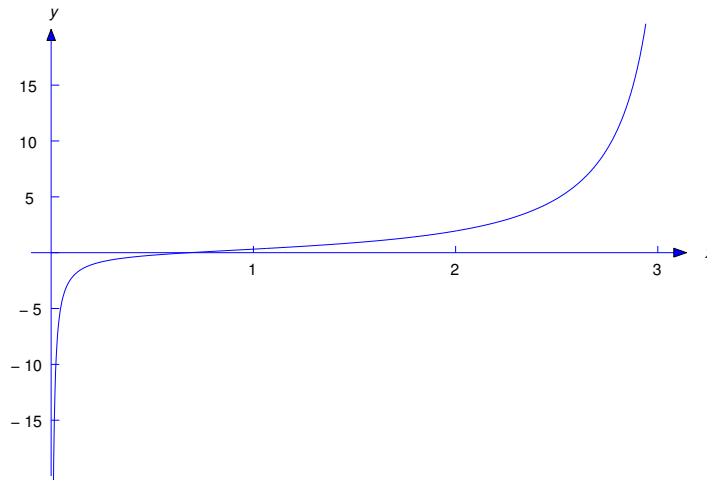

Figure 2.1.4 Solution of  $y' + (\cot x)y = x \csc x$ ,  $y(\pi/2) = 1$

REMARK: It wasn't necessary to do the computations (2.1.23) and (2.1.24) in Example 2.1.6, since we showed in the discussion preceding Example 2.1.5 that if  $y = uy_1$  where  $y_1' + p(x)y_1 = 0$ , then  $y' + p(x)y = u'y_1$ . We did these computations so you would see this happen in this specific example. We recommend that you include these "unnecessary" computations in doing exercises, until you're confident that you really understand the method. After that, omit them.

We summarize the method of variation of parameters for solving

$$y' + p(x)y = f(x) \quad (2.1.26)$$

as follows:

- (a) Find a function  $y_1$  such that

$$\frac{y_1'}{y_1} = -p(x).$$

For convenience, take the constant of integration to be zero.

- (b) Write

$$y = uy_1 \quad (2.1.27)$$

to remind yourself of what you're doing.

- (c) Write  $u'y_1 = f$  and solve for  $u'$ ; thus,  $u' = f/y_1$ .  
 (d) Integrate  $u'$  to obtain  $u$ , with an arbitrary constant of integration.  
 (e) Substitute  $u$  into (2.1.27) to obtain  $y$ .

To solve an equation written as

$$P_0(x)y' + P_1(x)y = F(x),$$

we recommend that you divide through by  $P_0(x)$  to obtain an equation of the form (2.1.26) and then follow this procedure.

### Solutions in Integral Form

Sometimes the integrals that arise in solving a linear first order equation can't be evaluated in terms of elementary functions. In this case the solution must be left in terms of an integral.

#### Example 2.1.7

- (a) Find the general solution of

$$y' - 2xy = 1.$$

- (b) Solve the initial value problem

$$y' - 2xy = 1, \quad y(0) = y_0. \quad (2.1.28)$$

**SOLUTION(a)** To apply variation of parameters, we need a nontrivial solution  $y_1$  of the complementary equation; thus,  $y_1' - 2xy_1 = 0$ , which we rewrite as

$$\frac{y_1'}{y_1} = 2x.$$

Integrating this and taking the constant of integration to be zero yields

$$\ln|y_1| = x^2, \quad \text{so} \quad |y_1| = e^{x^2}.$$

We choose  $y_1 = e^{x^2}$  and seek solutions of (2.1.28) in the form  $y = ue^{x^2}$ , where

$$u'e^{x^2} = 1, \quad \text{so} \quad u' = e^{-x^2}.$$

Therefore

$$u = c + \int e^{-x^2} dx,$$

but we can't simplify the integral on the right because there's no elementary function with derivative equal to  $e^{-x^2}$ . Therefore the best available form for the general solution of (2.1.28) is

$$y = ue^{x^2} = e^{x^2} \left( c + \int e^{-x^2} dx \right). \quad (2.1.29)$$

**SOLUTION(b)** Since the initial condition in (2.1.28) is imposed at  $x_0 = 0$ , it is convenient to rewrite (2.1.29) as

$$y = e^{x^2} \left( c + \int_0^x e^{-t^2} dt \right), \quad \text{since} \quad \int_0^0 e^{-t^2} dt = 0.$$

Setting  $x = 0$  and  $y = y_0$  here shows that  $c = y_0$ . Therefore the solution of the initial value problem is

$$y = e^{x^2} \left( y_0 + \int_0^x e^{-t^2} dt \right). \quad (2.1.30)$$

For a given value of  $y_0$  and each fixed  $x$ , the integral on the right can be evaluated by numerical methods. An alternate procedure is to apply the numerical integration procedures discussed in Chapter 3 directly to the initial value problem (2.1.28). Figure 2.1.5 shows graphs of (2.1.30) for several values of  $y_0$ .

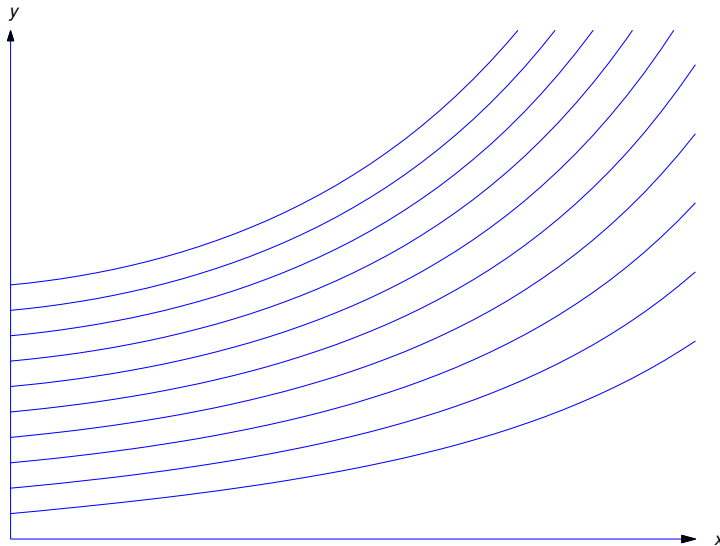

Figure 2.1.5 Solutions of  $y' - 2xy = 1$ ,  $y(0) = y_0$

**An Existence and Uniqueness Theorem**

The method of variation of parameters leads to this theorem.

**Theorem 2.1.2** *Suppose  $p$  and  $f$  are continuous on an open interval  $(a, b)$ , and let  $y_1$  be any nontrivial solution of the complementary equation*

$$y' + p(x)y = 0$$

on  $(a, b)$ . Then:

(a) *The general solution of the nonhomogeneous equation*

$$y' + p(x)y = f(x) \quad (2.1.31)$$

on  $(a, b)$  is

$$y = y_1(x) \left( c + \int f(x)/y_1(x) dx \right). \quad (2.1.32)$$

(b) *If  $x_0$  is an arbitrary point in  $(a, b)$  and  $y_0$  is an arbitrary real number, then the initial value problem*

$$y' + p(x)y = f(x), \quad y(x_0) = y_0$$

*has the unique solution*

$$y = y_1(x) \left( \frac{y_0}{y_1(x_0)} + \int_{x_0}^x \frac{f(t)}{y_1(t)} dt \right)$$

on  $(a, b)$ .

**Proof** (a) To show that (2.1.32) is the general solution of (2.1.31) on  $(a, b)$ , we must prove that:

(i) If  $c$  is any constant, the function  $y$  in (2.1.32) is a solution of (2.1.31) on  $(a, b)$ .

(ii) If  $y$  is a solution of (2.1.31) on  $(a, b)$  then  $y$  is of the form (2.1.32) for some constant  $c$ .

To prove (i), we first observe that any function of the form (2.1.32) is defined on  $(a, b)$ , since  $p$  and  $f$  are continuous on  $(a, b)$ . Differentiating (2.1.32) yields

$$y' = y_1'(x) \left( c + \int f(x)/y_1(x) dx \right) + f(x).$$

Since  $y_1' = -p(x)y_1$ , this and (2.1.32) imply that

$$\begin{aligned} y' &= -p(x)y_1(x) \left( c + \int f(x)/y_1(x) dx \right) + f(x) \\ &= -p(x)y(x) + f(x), \end{aligned}$$

which implies that  $y$  is a solution of (2.1.31).

To prove (ii), suppose  $y$  is a solution of (2.1.31) on  $(a, b)$ . From the proof of Theorem 2.1.1, we know that  $y_1$  has no zeros on  $(a, b)$ , so the function  $u = y/y_1$  is defined on  $(a, b)$ . Moreover, since

$$y' = -py + f \quad \text{and} \quad y_1' = -py_1,$$

$$\begin{aligned} u' &= \frac{y_1 y' - y_1' y}{y_1^2} \\ &= \frac{y_1(-py + f) - (-py_1)y}{y_1^2} = \frac{f}{y_1}. \end{aligned}$$

Integrating  $u' = f/y_1$  yields

$$u = \left( c + \int f(x)/y_1(x) dx \right),$$

which implies (2.1.32), since  $y = uy_1$ .

(b) We've proved (a), where  $\int f(x)/y_1(x) dx$  in (2.1.32) is an arbitrary antiderivative of  $f/y_1$ . Now it's convenient to choose the antiderivative that equals zero when  $x = x_0$ , and write the general solution of (2.1.31) as

$$y = y_1(x) \left( c + \int_{x_0}^x \frac{f(t)}{y_1(t)} dt \right).$$

Since

$$y(x_0) = y_1(x_0) \left( c + \int_{x_0}^{x_0} \frac{f(t)}{y_1(t)} dt \right) = cy_1(x_0),$$

we see that  $y(x_0) = y_0$  if and only if  $c = y_0/y_1(x_0)$ .

## 2.1 Exercises

---

In Exercises 1–5 find the general solution.

- |  |                     |
|--|---------------------|
| 1. $y' + ay = 0$ ( $a = \text{constant}$ ) | 2. $y' + 3x^2y = 0$ |
| 3. $xy' + (\ln x)y = 0$                    | 4. $xy' + 3y = 0$   |
| 5. $x^2y' + y = 0$                         |                     |

In Exercises 6–11 solve the initial value problem.

6.  $y' + \left( \frac{1+x}{x} \right) y = 0, \quad y(1) = 1$
7.  $xy' + \left( 1 + \frac{1}{\ln x} \right) y = 0, \quad y(e) = 1$
8.  $xy' + (1 + x \cot x)y = 0, \quad y\left(\frac{\pi}{2}\right) = 2$
9.  $y' - \left( \frac{2x}{1+x^2} \right) y = 0, \quad y(0) = 2$
10.  $y' + \frac{k}{x}y = 0, \quad y(1) = 3 \quad (k = \text{constant})$
11.  $y' + (\tan kx)y = 0, \quad y(0) = 2 \quad (k = \text{constant})$

In Exercises 12–15 find the general solution. Also, plot a direction field and some integral curves on the rectangular region  $\{-2 \leq x \leq 2, -2 \leq y \leq 2\}$ .

- |  |  |
|--|--|
| 12. <span style="border: 1px solid black; padding: 2px;">C/G</span> $y' + 3y = 1$          | 13. <span style="border: 1px solid black; padding: 2px;">C/G</span> $y' + \left( \frac{1}{x} - 1 \right) y = -\frac{2}{x}$ |
| 14. <span style="border: 1px solid black; padding: 2px;">C/G</span> $y' + 2xy = xe^{-x^2}$ | 15. <span style="border: 1px solid black; padding: 2px;">C/G</span> $y' + \frac{2x}{1+x^2}y = \frac{e^{-x}}{1+x^2}$        |

In Exercises 16–24 find the general solution.

16.  $y' + \frac{1}{x}y = \frac{7}{x^2} + 3$

17.  $y' + \frac{4}{x-1}y = \frac{1}{(x-1)^5} + \frac{\sin x}{(x-1)^4}$

18.  $xy' + (1 + 2x^2)y = x^3e^{-x^2}$

19.  $xy' + 2y = \frac{2}{x^2} + 1$

20.  $y' + (\tan x)y = \cos x$

21.  $(1+x)y' + 2y = \frac{\sin x}{1+x}$

22.  $(x-2)(x-1)y' - (4x-3)y = (x-2)^3$

23.  $y' + (2 \sin x \cos x)y = e^{-\sin^2 x}$

24.  $x^2y' + 3xy = e^x$

In Exercises 25–29 solve the initial value problem and sketch the graph of the solution.

25.  $\boxed{\text{C/G}} \quad y' + 7y = e^{3x}, \quad y(0) = 0$

26.  $\boxed{\text{C/G}} \quad (1+x^2)y' + 4xy = \frac{2}{1+x^2}, \quad y(0) = 1$

27.  $\boxed{\text{C/G}} \quad xy' + 3y = \frac{2}{x(1+x^2)}, \quad y(-1) = 0$

28.  $\boxed{\text{C/G}} \quad y' + (\cot x)y = \cos x, \quad y\left(\frac{\pi}{2}\right) = 1$

29.  $\boxed{\text{C/G}} \quad y' + \frac{1}{x}y = \frac{2}{x^2} + 1, \quad y(-1) = 0$

In Exercises 30–37 solve the initial value problem.

30.  $(x-1)y' + 3y = \frac{1}{(x-1)^3} + \frac{\sin x}{(x-1)^2}, \quad y(0) = 1$

31.  $xy' + 2y = 8x^2, \quad y(1) = 3$

32.  $xy' - 2y = -x^2, \quad y(1) = 1$

33.  $y' + 2xy = x, \quad y(0) = 3$

34.  $(x-1)y' + 3y = \frac{1 + (x-1)\sec^2 x}{(x-1)^3}, \quad y(0) = -1$

35.  $(x+2)y' + 4y = \frac{1+2x^2}{x(x+2)^3}, \quad y(-1) = 2$

36.  $(x^2-1)y' - 2xy = x(x^2-1), \quad y(0) = 4$

37.  $(x^2-5)y' - 2xy = -2x(x^2-5), \quad y(2) = 7$

In Exercises 38–42 solve the initial value problem and leave the answer in a form involving a definite integral. (You can solve these problems numerically by methods discussed in Chapter 3.)

38.  $y' + 2xy = x^2, \quad y(0) = 3$

39.  $y' + \frac{1}{x}y = \frac{\sin x}{x^2}, \quad y(1) = 2$

40.  $y' + y = \frac{e^{-x} \tan x}{x}, \quad y(1) = 0$



41.  $y' + \frac{2x}{1+x^2}y = \frac{e^x}{(1+x^2)^2}, \quad y(0) = 1$
42.  $xy' + (x+1)y = e^{x^2}, \quad y(1) = 2$
43. Experiments indicate that glucose is absorbed by the body at a rate proportional to the amount of glucose present in the bloodstream. Let  $\lambda$  denote the (positive) constant of proportionality. Now suppose glucose is injected into a patient's bloodstream at a constant rate of  $r$  units per unit of time. Let  $G = G(t)$  be the number of units in the patient's bloodstream at time  $t > 0$ . Then

$$G' = -\lambda G + r,$$

where the first term on the right is due to the absorption of the glucose by the patient's body and the second term is due to the injection. Determine  $G$  for  $t > 0$ , given that  $G(0) = G_0$ . Also, find  $\lim_{t \rightarrow \infty} G(t)$ .

44. (a) L Plot a direction field and some integral curves for

$$xy' - 2y = -1 \tag{A}$$

on the rectangular region  $\{-1 \leq x \leq 1, -0.5 \leq y \leq 1.5\}$ . What do all the integral curves have in common?

- (b) Show that the general solution of (A) on  $(-\infty, 0)$  and  $(0, \infty)$  is

$$y = \frac{1}{2} + cx^2.$$

- (c) Show that  $y$  is a solution of (A) on  $(-\infty, \infty)$  if and only if

$$y = \begin{cases} \frac{1}{2} + c_1x^2, & x \geq 0, \\ \frac{1}{2} + c_2x^2, & x < 0, \end{cases}$$

where  $c_1$  and  $c_2$  are arbitrary constants.

- (d) Conclude from (c) that all solutions of (A) on  $(-\infty, \infty)$  are solutions of the initial value problem

$$xy' - 2y = -1, \quad y(0) = \frac{1}{2}.$$

- (e) Use (b) to show that if  $x_0 \neq 0$  and  $y_0$  is arbitrary, then the initial value problem

$$xy' - 2y = -1, \quad y(x_0) = y_0$$

has infinitely many solutions on  $(-\infty, \infty)$ . Explain why this does not contradict Theorem 2.1.1(b).

45. Suppose  $f$  is continuous on an open interval  $(a, b)$  and  $\alpha$  is a constant.

- (a) Derive a formula for the solution of the initial value problem

$$y' + \alpha y = f(x), \quad y(x_0) = y_0, \tag{A}$$

where  $x_0$  is in  $(a, b)$  and  $y_0$  is an arbitrary real number.

- (b) Suppose  $(a, b) = (a, \infty)$ ,  $\alpha > 0$  and  $\lim_{x \rightarrow \infty} f(x) = L$ . Show that if  $y$  is the solution of (A), then  $\lim_{x \rightarrow \infty} y(x) = L/\alpha$ .

**46.** Assume that all functions in this exercise are defined on a common interval  $(a, b)$ .

(a) Prove: If  $y_1$  and  $y_2$  are solutions of

$$y' + p(x)y = f_1(x)$$

and

$$y' + p(x)y = f_2(x)$$

respectively, and  $c_1$  and  $c_2$  are constants, then  $y = c_1y_1 + c_2y_2$  is a solution of

$$y' + p(x)y = c_1f_1(x) + c_2f_2(x).$$

(This is the *principle of superposition*.)

(b) Use (a) to show that if  $y_1$  and  $y_2$  are solutions of the nonhomogeneous equation

$$y' + p(x)y = f(x), \tag{A}$$

then  $y_1 - y_2$  is a solution of the homogeneous equation

$$y' + p(x)y = 0. \tag{B}$$

(c) Use (a) to show that if  $y_1$  is a solution of (A) and  $y_2$  is a solution of (B), then  $y_1 + y_2$  is a solution of (A).

**47.** Some nonlinear equations can be transformed into linear equations by changing the dependent variable. Show that if

$$g'(y)y' + p(x)g(y) = f(x)$$

where  $y$  is a function of  $x$  and  $g$  is a function of  $y$ , then the new dependent variable  $z = g(y)$  satisfies the linear equation

$$z' + p(x)z = f(x).$$

**48.** Solve by the method discussed in Exercise 47.

(a)  $(\sec^2 y)y' - 3 \tan y = -1$

(b)  $e^{y^2} \left( 2yy' + \frac{2}{x} \right) = \frac{1}{x^2}$

(c)  $\frac{xy'}{y} + 2 \ln y = 4x^2$

(d)  $\frac{y'}{(1+y)^2} - \frac{1}{x(1+y)} = -\frac{3}{x^2}$

**49.** We've shown that if  $p$  and  $f$  are continuous on  $(a, b)$  then every solution of

$$y' + p(x)y = f(x) \tag{A}$$

on  $(a, b)$  can be written as  $y = uy_1$ , where  $y_1$  is a nontrivial solution of the complementary equation for (A) and  $u' = f/y_1$ . Now suppose  $f, f', \dots, f^{(m)}$  and  $p, p', \dots, p^{(m-1)}$  are continuous on  $(a, b)$ , where  $m$  is a positive integer, and define

$$\begin{aligned} f_0 &= f, \\ f_j &= f'_{j-1} + pf_{j-1}, \quad 1 \leq j \leq m. \end{aligned}$$

Show that

$$u^{(j+1)} = \frac{f_j}{y_1}, \quad 0 \leq j \leq m.$$

## 2.2 SEPARABLE EQUATIONS

A first order differential equation is *separable* if it can be written as

$$h(y)y' = g(x), \quad (2.2.1)$$

where the left side is a product of  $y'$  and a function of  $y$  and the right side is a function of  $x$ . Rewriting a separable differential equation in this form is called *separation of variables*. In Section 2.1 we used separation of variables to solve homogeneous linear equations. In this section we'll apply this method to nonlinear equations.

To see how to solve (2.2.1), let's first assume that  $y$  is a solution. Let  $G(x)$  and  $H(y)$  be antiderivatives of  $g(x)$  and  $h(y)$ ; that is,

$$H'(y) = h(y) \quad \text{and} \quad G'(x) = g(x). \quad (2.2.2)$$

Then, from the chain rule,

$$\frac{d}{dx}H(y(x)) = H'(y(x))y'(x) = h(y)y'(x).$$

Therefore (2.2.1) is equivalent to

$$\frac{d}{dx}H(y(x)) = \frac{d}{dx}G(x).$$

Integrating both sides of this equation and combining the constants of integration yields

$$H(y(x)) = G(x) + c. \quad (2.2.3)$$

Although we derived this equation on the assumption that  $y$  is a solution of (2.2.1), we can now view it differently: Any differentiable function  $y$  that satisfies (2.2.3) for some constant  $c$  is a solution of (2.2.1). To see this, we differentiate both sides of (2.2.3), using the chain rule on the left, to obtain

$$H'(y(x))y'(x) = G'(x),$$

which is equivalent to

$$h(y(x))y'(x) = g(x)$$

because of (2.2.2).

In conclusion, to solve (2.2.1) it suffices to find functions  $G = G(x)$  and  $H = H(y)$  that satisfy (2.2.2). Then any differentiable function  $y = y(x)$  that satisfies (2.2.3) is a solution of (2.2.1).

**Example 2.2.1** Solve the equation

$$y' = x(1 + y^2).$$

**Solution** Separating variables yields

$$\frac{y'}{1 + y^2} = x.$$

Integrating yields

$$\tan^{-1} y = \frac{x^2}{2} + c$$

Therefore

$$y = \tan\left(\frac{x^2}{2} + c\right).$$

**Example 2.2.2**

(a) Solve the equation

$$y' = -\frac{x}{y}. \quad (2.2.4)$$

(b) Solve the initial value problem

$$y' = -\frac{x}{y}, \quad y(1) = 1. \quad (2.2.5)$$

(c) Solve the initial value problem

$$y' = -\frac{x}{y}, \quad y(1) = -2. \quad (2.2.6)$$

**SOLUTION(a)** Separating variables in (2.2.4) yields

$$yy' = -x.$$

Integrating yields

$$\frac{y^2}{2} = -\frac{x^2}{2} + c, \quad \text{or, equivalently,} \quad x^2 + y^2 = 2c.$$

The last equation shows that  $c$  must be positive if  $y$  is to be a solution of (2.2.4) on an open interval. Therefore we let  $2c = a^2$  (with  $a > 0$ ) and rewrite the last equation as

$$x^2 + y^2 = a^2. \quad (2.2.7)$$

This equation has two differentiable solutions for  $y$  in terms of  $x$ :

$$y = \sqrt{a^2 - x^2}, \quad -a < x < a, \quad (2.2.8)$$

and

$$y = -\sqrt{a^2 - x^2}, \quad -a < x < a. \quad (2.2.9)$$

The solution curves defined by (2.2.8) are semicircles above the  $x$ -axis and those defined by (2.2.9) are semicircles below the  $x$ -axis (Figure 2.2.1).

**SOLUTION(b)** The solution of (2.2.5) is positive when  $x = 1$ ; hence, it is of the form (2.2.8). Substituting  $x = 1$  and  $y = 1$  into (2.2.7) to satisfy the initial condition yields  $a^2 = 2$ ; hence, the solution of (2.2.5) is

$$y = \sqrt{2 - x^2}, \quad -\sqrt{2} < x < \sqrt{2}.$$

**SOLUTION(c)** The solution of (2.2.6) is negative when  $x = 1$  and is therefore of the form (2.2.9). Substituting  $x = 1$  and  $y = -2$  into (2.2.7) to satisfy the initial condition yields  $a^2 = 5$ . Hence, the solution of (2.2.6) is

$$y = -\sqrt{5 - x^2}, \quad -\sqrt{5} < x < \sqrt{5}.$$

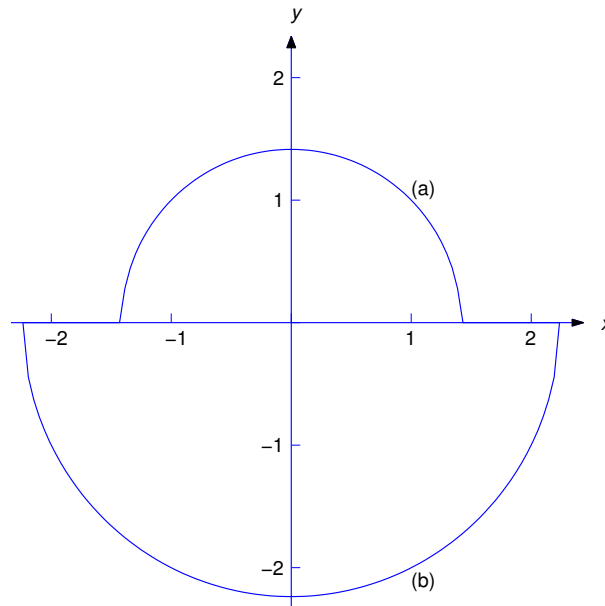

Figure 2.2.1 (a)  $y = \sqrt{2 - x^2}$ ,  $-\sqrt{2} < x < \sqrt{2}$ ; (b)  $y = -\sqrt{5 - x^2}$ ,  $-\sqrt{5} < x < \sqrt{5}$

### Implicit Solutions of Separable Equations

In Examples 2.2.1 and 2.2.2 we were able to solve the equation  $H(y) = G(x) + c$  to obtain explicit formulas for solutions of the given separable differential equations. As we'll see in the next example, this isn't always possible. In this situation we must broaden our definition of a solution of a separable equation. The next theorem provides the basis for this modification. We omit the proof, which requires a result from advanced calculus called as the *implicit function theorem*.

**Theorem 2.2.1** Suppose  $g = g(x)$  is continuous on  $(a, b)$  and  $h = h(y)$  are continuous on  $(c, d)$ . Let  $G$  be an antiderivative of  $g$  on  $(a, b)$  and let  $H$  be an antiderivative of  $h$  on  $(c, d)$ . Let  $x_0$  be an arbitrary point in  $(a, b)$ , let  $y_0$  be a point in  $(c, d)$  such that  $h(y_0) \neq 0$ , and define

$$c = H(y_0) - G(x_0). \quad (2.2.10)$$

Then there's a function  $y = y(x)$  defined on some open interval  $(a_1, b_1)$ , where  $a \leq a_1 < x_0 < b_1 \leq b$ , such that  $y(x_0) = y_0$  and

$$H(y) = G(x) + c \quad (2.2.11)$$

for  $a_1 < x < b_1$ . Therefore  $y$  is a solution of the initial value problem

$$h(y)y' = g(x), \quad y(x_0) = y_0. \quad (2.2.12)$$

It's convenient to say that (2.2.11) with  $c$  arbitrary is an *implicit solution* of  $h(y)y' = g(x)$ . Curves defined by (2.2.11) are integral curves of  $h(y)y' = g(x)$ . If  $c$  satisfies (2.2.10), we'll say that (2.2.11) is an *implicit solution of the initial value problem* (2.2.12). However, keep these points in mind:

- For some choices of  $c$  there may not be any differentiable functions  $y$  that satisfy (2.2.11).

- The function  $y$  in (2.2.11) (not (2.2.11) itself) is a solution of  $h(y)y' = g(x)$ .

**Example 2.2.3**

- (a) Find implicit solutions of

$$y' = \frac{2x + 1}{5y^4 + 1}. \quad (2.2.13)$$

- (b) Find an implicit solution of

$$y' = \frac{2x + 1}{5y^4 + 1}, \quad y(2) = 1. \quad (2.2.14)$$

**SOLUTION(a)** Separating variables yields

$$(5y^4 + 1)y' = 2x + 1.$$

Integrating yields the implicit solution

$$y^5 + y = x^2 + x + c. \quad (2.2.15)$$

of (2.2.13).

**SOLUTION(b)** Imposing the initial condition  $y(2) = 1$  in (2.2.15) yields  $1 + 1 = 4 + 2 + c$ , so  $c = -4$ . Therefore

$$y^5 + y = x^2 + x - 4$$

is an implicit solution of the initial value problem (2.2.14). Although more than one differentiable function  $y = y(x)$  satisfies 2.2.13 near  $x = 1$ , it can be shown that there's only one such function that satisfies the initial condition  $y(1) = 2$ .

Figure 2.2.2 shows a direction field and some integral curves for (2.2.13).

**Constant Solutions of Separable Equations**

An equation of the form

$$y' = g(x)p(y)$$

is separable, since it can be rewritten as

$$\frac{1}{p(y)}y' = g(x).$$

However, the division by  $p(y)$  is not legitimate if  $p(y) = 0$  for some values of  $y$ . The next two examples show how to deal with this problem.**Example 2.2.4** Find all solutions of

$$y' = 2xy^2. \quad (2.2.16)$$

**Solution** Here we must divide by  $p(y) = y^2$  to separate variables. This isn't legitimate if  $y$  is a solution of (2.2.16) that equals zero for some value of  $x$ . One such solution can be found by inspection:  $y \equiv 0$ . Now suppose  $y$  is a solution of (2.2.16) that isn't identically zero. Since  $y$  is continuous there must be an interval on which  $y$  is never zero. Since division by  $y^2$  is legitimate for  $x$  in this interval, we can separate variables in (2.2.16) to obtain

$$\frac{y'}{y^2} = 2x.$$

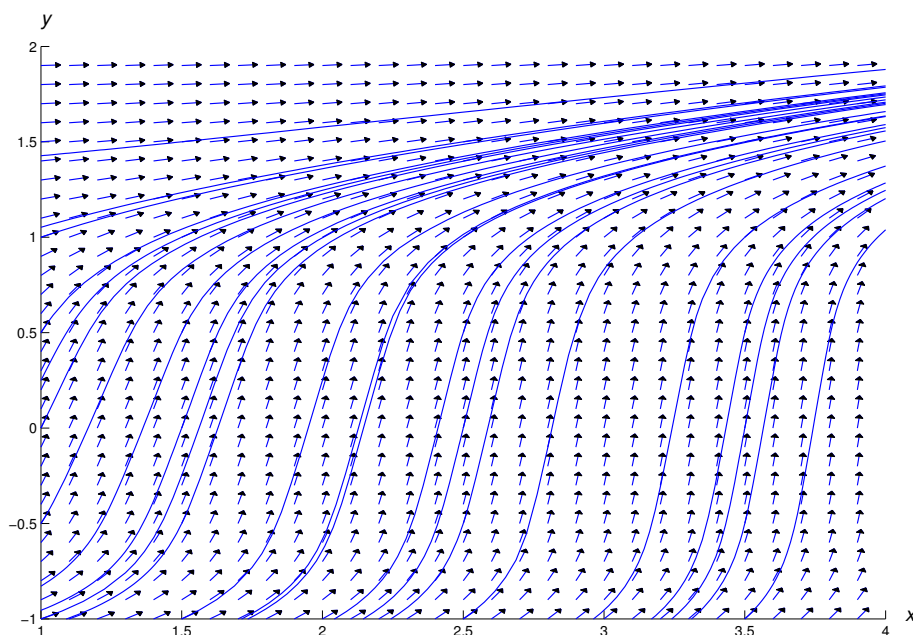

Figure 2.2.2 A direction field and integral curves for  $y' = \frac{2x + 1}{5y^4 + 1}$

Integrating this yields

$$-\frac{1}{y} = x^2 + c,$$

which is equivalent to

$$y = -\frac{1}{x^2 + c}. \quad (2.2.17)$$

We've now shown that if  $y$  is a solution of (2.2.16) that is not identically zero, then  $y$  must be of the form (2.2.17). By substituting (2.2.17) into (2.2.16), you can verify that (2.2.17) is a solution of (2.2.16). Thus, solutions of (2.2.16) are  $y \equiv 0$  and the functions of the form (2.2.17). Note that the solution  $y \equiv 0$  isn't of the form (2.2.17) for any value of  $c$ .

Figure 2.2.3 shows a direction field and some integral curves for (2.2.16)

**Example 2.2.5** Find all solutions of

$$y' = \frac{1}{2}x(1 - y^2). \quad (2.2.18)$$

**Solution** Here we must divide by  $p(y) = 1 - y^2$  to separate variables. This isn't legitimate if  $y$  is a solution of (2.2.18) that equals  $\pm 1$  for some value of  $x$ . Two such solutions can be found by inspection:  $y \equiv 1$  and  $y \equiv -1$ . Now suppose  $y$  is a solution of (2.2.18) such that  $1 - y^2$  isn't identically zero. Since  $1 - y^2$  is continuous there must be an interval on which  $1 - y^2$  is never zero. Since division by  $1 - y^2$  is legitimate for  $x$  in this interval, we can separate variables in (2.2.18) to obtain

$$\frac{2y'}{y^2 - 1} = -x.$$

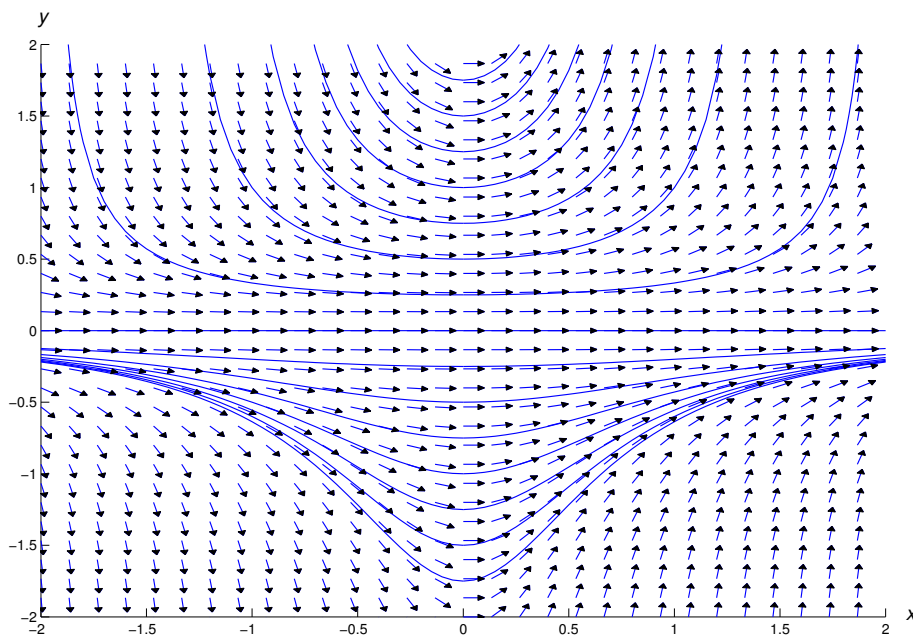
Figure 2.2.3 A direction field and integral curves for  $y' = 2xy^2$ 

A partial fraction expansion on the left yields

$$\left[ \frac{1}{y-1} - \frac{1}{y+1} \right] y' = -x,$$

and integrating yields

$$\ln \left| \frac{y-1}{y+1} \right| = -\frac{x^2}{2} + k;$$

hence,

$$\left| \frac{y-1}{y+1} \right| = e^k e^{-x^2/2}.$$

Since  $y(x) \neq \pm 1$  for  $x$  on the interval under discussion, the quantity  $(y-1)/(y+1)$  can't change sign in this interval. Therefore we can rewrite the last equation as

$$\frac{y-1}{y+1} = ce^{-x^2/2},$$

where  $c = \pm e^k$ , depending upon the sign of  $(y-1)/(y+1)$  on the interval. Solving for  $y$  yields

$$y = \frac{1 + ce^{-x^2/2}}{1 - ce^{-x^2/2}}. \quad (2.2.19)$$

We've now shown that if  $y$  is a solution of (2.2.18) that is not identically equal to  $\pm 1$ , then  $y$  must be as in (2.2.19). By substituting (2.2.19) into (2.2.18) you can verify that (2.2.19) is a solution of (2.2.18). Thus, the solutions of (2.2.18) are  $y \equiv 1$ ,  $y \equiv -1$  and the functions of the form (2.2.19). Note that the



constant solution  $y \equiv 1$  can be obtained from this formula by taking  $c = 0$ ; however, the other constant solution,  $y \equiv -1$ , can't be obtained in this way.

Figure 2.2.4 shows a direction field and some integrals for (2.2.18).

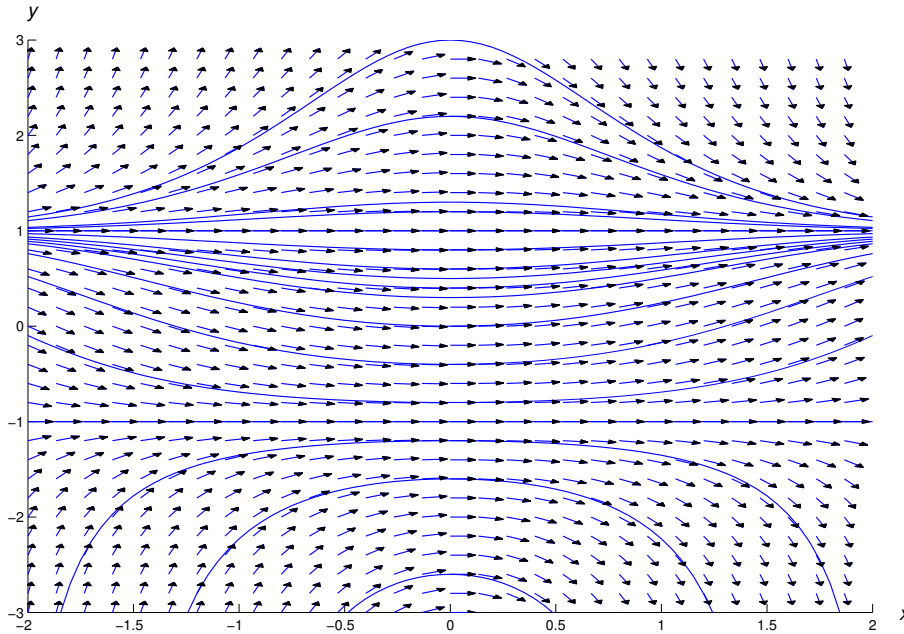

Figure 2.2.4 A direction field and integral curves for  $y' = \frac{x(1-y^2)}{2}$

### Differences Between Linear and Nonlinear Equations

Theorem 2.1.2 states that if  $p$  and  $f$  are continuous on  $(a, b)$  then every solution of

$$y' + p(x)y = f(x)$$

on  $(a, b)$  can be obtained by choosing a value for the constant  $c$  in the general solution, and if  $x_0$  is any point in  $(a, b)$  and  $y_0$  is arbitrary, then the initial value problem

$$y' + p(x)y = f(x), \quad y(x_0) = y_0$$

has a solution on  $(a, b)$ .

This is not true for nonlinear equations. First, we saw in Examples 2.2.4 and 2.2.5 that a nonlinear equation may have solutions that can't be obtained by choosing a specific value of a constant appearing in a one-parameter family of solutions. Second, it is in general impossible to determine the interval of validity of a solution to an initial value problem for a nonlinear equation by simply examining the equation, since the interval of validity may depend on the initial condition. For instance, in Example 2.2.2 we saw that the solution of

$$\frac{dy}{dx} = -\frac{x}{y}, \quad y(x_0) = y_0$$

is valid on  $(-a, a)$ , where  $a = \sqrt{x_0^2 + y_0^2}$ .

**Example 2.2.6** Solve the initial value problem

$$y' = 2xy^2, \quad y(0) = y_0$$

and determine the interval of validity of the solution.

**Solution** First suppose  $y_0 \neq 0$ . From Example 2.2.4, we know that  $y$  must be of the form

$$y = -\frac{1}{x^2 + c}. \quad (2.2.20)$$

Imposing the initial condition shows that  $c = -1/y_0$ . Substituting this into (2.2.20) and rearranging terms yields the solution

$$y = \frac{y_0}{1 - y_0 x^2}.$$

This is also the solution if  $y_0 = 0$ . If  $y_0 < 0$ , the denominator isn't zero for any value of  $x$ , so the solution is valid on  $(-\infty, \infty)$ . If  $y_0 > 0$ , the solution is valid only on  $(-1/\sqrt{y_0}, 1/\sqrt{y_0})$ .

## 2.2 Exercises

---

In Exercises 1–6 find all solutions.

1.  $y' = \frac{3x^2 + 2x + 1}{y - 2}$
2.  $(\sin x)(\sin y) + (\cos y)y' = 0$
3.  $xy' + y^2 + y = 0$
4.  $y' \ln |y| + x^2 y = 0$
5.  $(3y^3 + 3y \cos y + 1)y' + \frac{(2x + 1)y}{1 + x^2} = 0$
6.  $x^2 y y' = (y^2 - 1)^{3/2}$

In Exercises 7–10 find all solutions. Also, plot a direction field and some integral curves on the indicated rectangular region.

7. C/G  $y' = x^2(1 + y^2)$ ;  $\{-1 \leq x \leq 1, -1 \leq y \leq 1\}$
8. C/G  $y'(1 + x^2) + xy = 0$ ;  $\{-2 \leq x \leq 2, -1 \leq y \leq 1\}$
9. C/G  $y' = (x - 1)(y - 1)(y - 2)$ ;  $\{-2 \leq x \leq 2, -3 \leq y \leq 3\}$
10. C/G  $(y - 1)^2 y' = 2x + 3$ ;  $\{-2 \leq x \leq 2, -2 \leq y \leq 5\}$

In Exercises 11 and 12 solve the initial value problem.

11.  $y' = \frac{x^2 + 3x + 2}{y - 2}, \quad y(1) = 4$
12.  $y' + x(y^2 + y) = 0, \quad y(2) = 1$

In Exercises 13–16 solve the initial value problem and graph the solution.

13. C/G  $(3y^2 + 4y)y' + 2x + \cos x = 0, \quad y(0) = 1$

14. C/G  $y' + \frac{(y+1)(y-1)(y-2)}{x+1} = 0, \quad y(1) = 0$

15. C/G  $y' + 2x(y+1) = 0, \quad y(0) = 2$

16. C/G  $y' = 2xy(1+y^2), \quad y(0) = 1$

In Exercises 17–23 solve the initial value problem and find the interval of validity of the solution.

17.  $y'(x^2 + 2) + 4x(y^2 + 2y + 1) = 0, \quad y(1) = -1$

18.  $y' = -2x(y^2 - 3y + 2), \quad y(0) = 3$

19.  $y' = \frac{2x}{1+2y}, \quad y(2) = 0$       20.  $y' = 2y - y^2, \quad y(0) = 1$

21.  $x + yy' = 0, \quad y(3) = -4$

22.  $y' + x^2(y+1)(y-2)^2 = 0, \quad y(4) = 2$

23.  $(x+1)(x-2)y' + y = 0, \quad y(1) = -3$

24. Solve  $y' = \frac{(1+y^2)}{(1+x^2)}$  explicitly. HINT: Use the identity  $\tan(A+B) = \frac{\tan A + \tan B}{1 - \tan A \tan B}$ .

25. Solve  $y' \sqrt{1-x^2} + \sqrt{1-y^2} = 0$  explicitly. HINT: Use the identity  $\sin(A-B) = \sin A \cos B - \cos A \sin B$ .

26. Solve  $y' = \frac{\cos x}{\sin y}, \quad y(\pi) = \frac{\pi}{2}$  explicitly. HINT: Use the identity  $\cos(x + \pi/2) = -\sin x$  and the periodicity of the cosine.

27. Solve the initial value problem

$$y' = ay - by^2, \quad y(0) = y_0.$$

Discuss the behavior of the solution if (a)  $y_0 \geq 0$ ; (b)  $y_0 < 0$ .

28. The population  $P = P(t)$  of a species satisfies the logistic equation

$$P' = aP(1 - \alpha P)$$

and  $P(0) = P_0 > 0$ . Find  $P$  for  $t > 0$ , and find  $\lim_{t \rightarrow \infty} P(t)$ .

29. An epidemic spreads through a population at a rate proportional to the product of the number of people already infected and the number of people susceptible, but not yet infected. Therefore, if  $S$  denotes the total population of susceptible people and  $I = I(t)$  denotes the number of infected people at time  $t$ , then

$$I' = rI(S - I),$$

where  $r$  is a positive constant. Assuming that  $I(0) = I_0$ , find  $I(t)$  for  $t > 0$ , and show that  $\lim_{t \rightarrow \infty} I(t) = S$ .

30. L The result of Exercise 29 is discouraging: if any susceptible member of the group is initially infected, then in the long run all susceptible members are infected! On a more hopeful note, suppose the disease spreads according to the model of Exercise 29, but there's a medication that cures the infected population at a rate proportional to the number of infected individuals. Now the equation for the number of infected individuals becomes

$$I' = rI(S - I) - qI \tag{A}$$

where  $q$  is a positive constant.

- (a) Choose  $r$  and  $S$  positive. By plotting direction fields and solutions of (A) on suitable rectangular grids

$$R = \{0 \leq t \leq T, 0 \leq I \leq d\}$$

in the  $(t, I)$ -plane, verify that if  $I$  is any solution of (A) such that  $I(0) > 0$ , then  $\lim_{t \rightarrow \infty} I(t) = S - q/r$  if  $q < rS$  and  $\lim_{t \rightarrow \infty} I(t) = 0$  if  $q \geq rS$ .

- (b) To verify the experimental results of (a), use separation of variables to solve (A) with initial condition  $I(0) = I_0 > 0$ , and find  $\lim_{t \rightarrow \infty} I(t)$ . HINT: *There are three cases to consider: (i)  $q < rS$ ; (ii)  $q > rS$ ; (iii)  $q = rS$ .*

31. **L** Consider the differential equation

$$y' = ay - by^2 - q, \quad (\text{A})$$

where  $a, b$  are positive constants, and  $q$  is an arbitrary constant. Suppose  $y$  denotes a solution of this equation that satisfies the initial condition  $y(0) = y_0$ .

- (a) Choose  $a$  and  $b$  positive and  $q < a^2/4b$ . By plotting direction fields and solutions of (A) on suitable rectangular grids

$$R = \{0 \leq t \leq T, c \leq y \leq d\} \quad (\text{B})$$

in the  $(t, y)$ -plane, discover that there are numbers  $y_1$  and  $y_2$  with  $y_1 < y_2$  such that if  $y_0 > y_1$  then  $\lim_{t \rightarrow \infty} y(t) = y_2$ , and if  $y_0 < y_1$  then  $y(t) = -\infty$  for some finite value of  $t$ . (What happens if  $y_0 = y_1$ ?)

- (b) Choose  $a$  and  $b$  positive and  $q = a^2/4b$ . By plotting direction fields and solutions of (A) on suitable rectangular grids of the form (B), discover that there's a number  $y_1$  such that if  $y_0 \geq y_1$  then  $\lim_{t \rightarrow \infty} y(t) = y_1$ , while if  $y_0 < y_1$  then  $y(t) = -\infty$  for some finite value of  $t$ .
- (c) Choose positive  $a, b$  and  $q > a^2/4b$ . By plotting direction fields and solutions of (A) on suitable rectangular grids of the form (B), discover that no matter what  $y_0$  is,  $y(t) = -\infty$  for some finite value of  $t$ .
- (d) Verify your results experiments analytically. Start by separating variables in (A) to obtain

$$\frac{y'}{ay - by^2 - q} = 1.$$

To decide what to do next you'll have to use the quadratic formula. This should lead you to see why there are three cases. Take it from there!

Because of its role in the transition between these three cases,  $q_0 = a^2/4b$  is called a *bifurcation value* of  $q$ . In general, if  $q$  is a parameter in any differential equation,  $q_0$  is said to be a bifurcation value of  $q$  if the nature of the solutions of the equation with  $q < q_0$  is qualitatively different from the nature of the solutions with  $q > q_0$ .

32. **L** By plotting direction fields and solutions of

$$y' = qy - y^3,$$

convince yourself that  $q_0 = 0$  is a bifurcation value of  $q$  for this equation. Explain what makes you draw this conclusion.

33. Suppose a disease spreads according to the model of Exercise 29, but there's a medication that cures the infected population at a constant rate of  $q$  individuals per unit time, where  $q > 0$ . Then the equation for the number of infected individuals becomes

$$I' = rI(S - I) - q.$$

Assuming that  $I(0) = I_0 > 0$ , use the results of Exercise 31 to describe what happens as  $t \rightarrow \infty$ .

34. Assuming that  $p \neq 0$ , state conditions under which the linear equation

$$y' + p(x)y = f(x)$$

is separable. If the equation satisfies these conditions, solve it by separation of variables and by the method developed in Section 2.1.

Solve the equations in Exercises 35–38 using variation of parameters followed by separation of variables.

35.  $y' + y = \frac{2xe^{-x}}{1 + ye^x}$

36.  $xy' - 2y = \frac{x^6}{y + x^2}$

37.  $y' - y = \frac{(x + 1)e^{4x}}{(y + e^x)^2}$

38.  $y' - 2y = \frac{xe^{2x}}{1 - ye^{-2x}}$

39. Use variation of parameters to show that the solutions of the following equations are of the form  $y = uy_1$ , where  $u$  satisfies a separable equation  $u' = g(x)p(u)$ . Find  $y_1$  and  $g$  for each equation.

(a)  $xy' + y = h(x)p(xy)$

(b)  $xy' - y = h(x)p\left(\frac{y}{x}\right)$

(c)  $y' + y = h(x)p(e^x y)$

(d)  $xy' + ry = h(x)p(x^r y)$

(e)  $y' + \frac{v'(x)}{v(x)}y = h(x)p(v(x)y)$

### 2.3 EXISTENCE AND UNIQUENESS OF SOLUTIONS OF NONLINEAR EQUATIONS

Although there are methods for solving some nonlinear equations, it's impossible to find useful formulas for the solutions of most. Whether we're looking for exact solutions or numerical approximations, it's useful to know conditions that imply the existence and uniqueness of solutions of initial value problems for nonlinear equations. In this section we state such a condition and illustrate it with examples.

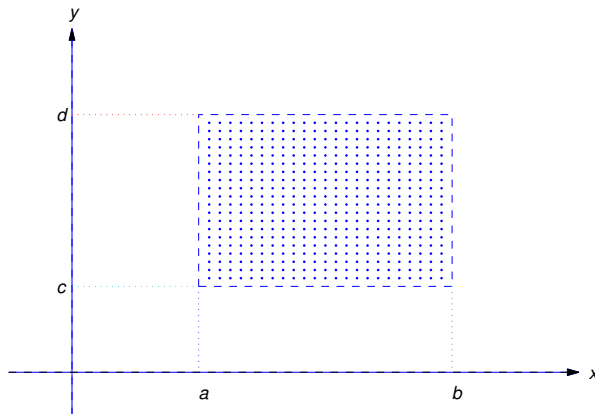

Figure 2.3.1 An open rectangle

Some terminology: an *open rectangle*  $R$  is a set of points  $(x, y)$  such that

$$a < x < b \quad \text{and} \quad c < y < d$$

(Figure 2.3.1). We'll denote this set by  $R : \{a < x < b, c < y < d\}$ . "Open" means that the boundary rectangle (indicated by the dashed lines in Figure 2.3.1) isn't included in  $R$ .

The next theorem gives sufficient conditions for existence and uniqueness of solutions of initial value problems for first order nonlinear differential equations. We omit the proof, which is beyond the scope of this book.

**Theorem 2.3.1**

(a) *If  $f$  is continuous on an open rectangle*

$$R : \{a < x < b, c < y < d\}$$

*that contains  $(x_0, y_0)$  then the initial value problem*

$$y' = f(x, y), \quad y(x_0) = y_0 \tag{2.3.1}$$

*has at least one solution on some open subinterval of  $(a, b)$  that contains  $x_0$ .*

(b) *If both  $f$  and  $f_y$  are continuous on  $R$  then (2.3.1) has a unique solution on some open subinterval of  $(a, b)$  that contains  $x_0$ .*

It's important to understand exactly what Theorem 2.3.1 says.

- (a) is an *existence theorem*. It guarantees that a solution exists on some open interval that contains  $x_0$ , but provides no information on how to find the solution, or to determine the open interval on which it exists. Moreover, (a) provides no information on the number of solutions that (2.3.1) may have. It leaves open the possibility that (2.3.1) may have two or more solutions that differ for values of  $x$  arbitrarily close to  $x_0$ . We will see in Example 2.3.6 that this can happen.
- (b) is a *uniqueness theorem*. It guarantees that (2.3.1) has a unique solution on some open interval  $(a, b)$  that contains  $x_0$ . However, if  $(a, b) \neq (-\infty, \infty)$ , (2.3.1) may have more than one solution on a larger interval that contains  $(a, b)$ . For example, it may happen that  $b < \infty$  and all solutions have the same values on  $(a, b)$ , but two solutions  $y_1$  and  $y_2$  are defined on some interval  $(a, b_1)$  with  $b_1 > b$ , and have different values for  $b < x < b_1$ ; thus, the graphs of the  $y_1$  and  $y_2$  "branch off" in different directions at  $x = b$ . (See Example 2.3.7 and Figure 2.3.3). In this case, continuity implies that  $y_1(b) = y_2(b)$  (call their common value  $\bar{y}$ ), and  $y_1$  and  $y_2$  are both solutions of the initial value problem

$$y' = f(x, y), \quad y(b) = \bar{y} \tag{2.3.2}$$

that differ on every open interval that contains  $b$ . Therefore  $f$  or  $f_y$  must have a discontinuity at some point in each open rectangle that contains  $(b, \bar{y})$ , since if this were not so, (2.3.2) would have a unique solution on some open interval that contains  $b$ . We leave it to you to give a similar analysis of the case where  $a > -\infty$ .

**Example 2.3.1** Consider the initial value problem

$$y' = \frac{x^2 - y^2}{1 + x^2 + y^2}, \quad y(x_0) = y_0. \tag{2.3.3}$$

Since

$$f(x, y) = \frac{x^2 - y^2}{1 + x^2 + y^2} \quad \text{and} \quad f_y(x, y) = -\frac{2y(1 + 2x^2)}{(1 + x^2 + y^2)^2}$$

are continuous for all  $(x, y)$ , Theorem 2.3.1 implies that if  $(x_0, y_0)$  is arbitrary, then (2.3.3) has a unique solution on some open interval that contains  $x_0$ .

**Example 2.3.2** Consider the initial value problem

$$y' = \frac{x^2 - y^2}{x^2 + y^2}, \quad y(x_0) = y_0. \quad (2.3.4)$$

Here

$$f(x, y) = \frac{x^2 - y^2}{x^2 + y^2} \quad \text{and} \quad f_y(x, y) = -\frac{4x^2y}{(x^2 + y^2)^2}$$

are continuous everywhere except at  $(0, 0)$ . If  $(x_0, y_0) \neq (0, 0)$ , there's an open rectangle  $R$  that contains  $(x_0, y_0)$  that does not contain  $(0, 0)$ . Since  $f$  and  $f_y$  are continuous on  $R$ , Theorem 2.3.1 implies that if  $(x_0, y_0) \neq (0, 0)$  then (2.3.4) has a unique solution on some open interval that contains  $x_0$ .

**Example 2.3.3** Consider the initial value problem

$$y' = \frac{x + y}{x - y}, \quad y(x_0) = y_0. \quad (2.3.5)$$

Here

$$f(x, y) = \frac{x + y}{x - y} \quad \text{and} \quad f_y(x, y) = \frac{2x}{(x - y)^2}$$

are continuous everywhere except on the line  $y = x$ . If  $y_0 \neq x_0$ , there's an open rectangle  $R$  that contains  $(x_0, y_0)$  that does not intersect the line  $y = x$ . Since  $f$  and  $f_y$  are continuous on  $R$ , Theorem 2.3.1 implies that if  $y_0 \neq x_0$ , (2.3.5) has a unique solution on some open interval that contains  $x_0$ .

**Example 2.3.4** In Example 2.2.4 we saw that the solutions of

$$y' = 2xy^2 \quad (2.3.6)$$

are

$$y \equiv 0 \quad \text{and} \quad y = -\frac{1}{x^2 + c},$$

where  $c$  is an arbitrary constant. In particular, this implies that no solution of (2.3.6) other than  $y \equiv 0$  can equal zero for any value of  $x$ . Show that Theorem 2.3.1(b) implies this.

**Solution** We'll obtain a contradiction by assuming that (2.3.6) has a solution  $y_1$  that equals zero for some value of  $x$ , but isn't identically zero. If  $y_1$  has this property, there's a point  $x_0$  such that  $y_1(x_0) = 0$ , but  $y_1(x) \neq 0$  for some value of  $x$  in every open interval that contains  $x_0$ . This means that the initial value problem

$$y' = 2xy^2, \quad y(x_0) = 0 \quad (2.3.7)$$

has two solutions  $y \equiv 0$  and  $y = y_1$  that differ for some value of  $x$  on every open interval that contains  $x_0$ . This contradicts Theorem 2.3.1(b), since in (2.3.6) the functions

$$f(x, y) = 2xy^2 \quad \text{and} \quad f_y(x, y) = 4xy.$$

are both continuous for all  $(x, y)$ , which implies that (2.3.7) has a unique solution on some open interval that contains  $x_0$ .

**Example 2.3.5** Consider the initial value problem

$$y' = \frac{10}{3}xy^{2/5}, \quad y(x_0) = y_0. \quad (2.3.8)$$

- (a) For what points  $(x_0, y_0)$  does Theorem 2.3.1(a) imply that (2.3.8) has a solution?  
 (b) For what points  $(x_0, y_0)$  does Theorem 2.3.1(b) imply that (2.3.8) has a unique solution on some open interval that contains  $x_0$ ?

**SOLUTION(a)** Since

$$f(x, y) = \frac{10}{3}xy^{2/5}$$

is continuous for all  $(x, y)$ , Theorem 2.3.1 implies that (2.3.8) has a solution for every  $(x_0, y_0)$ .

**SOLUTION(b)** Here

$$f_y(x, y) = \frac{4}{3}xy^{-3/5}$$

is continuous for all  $(x, y)$  with  $y \neq 0$ . Therefore, if  $y_0 \neq 0$  there's an open rectangle on which both  $f$  and  $f_y$  are continuous, and Theorem 2.3.1 implies that (2.3.8) has a unique solution on some open interval that contains  $x_0$ .

If  $y = 0$  then  $f_y(x, y)$  is undefined, and therefore discontinuous; hence, Theorem 2.3.1 does not apply to (2.3.8) if  $y_0 = 0$ .

**Example 2.3.6** Example 2.3.5 leaves open the possibility that the initial value problem

$$y' = \frac{10}{3}xy^{2/5}, \quad y(0) = 0 \quad (2.3.9)$$

has more than one solution on every open interval that contains  $x_0 = 0$ . Show that this is true.

**Solution** By inspection,  $y \equiv 0$  is a solution of the differential equation

$$y' = \frac{10}{3}xy^{2/5}. \quad (2.3.10)$$

Since  $y \equiv 0$  satisfies the initial condition  $y(0) = 0$ , it's a solution of (2.3.9).

Now suppose  $y$  is a solution of (2.3.10) that isn't identically zero. Separating variables in (2.3.10) yields

$$y^{-2/5}y' = \frac{10}{3}x$$

on any open interval where  $y$  has no zeros. Integrating this and rewriting the arbitrary constant as  $5c/3$  yields

$$\frac{5}{3}y^{3/5} = \frac{5}{3}(x^2 + c).$$

Therefore

$$y = (x^2 + c)^{5/3}. \quad (2.3.11)$$

Since we divided by  $y$  to separate variables in (2.3.10), our derivation of (2.3.11) is legitimate only on open intervals where  $y$  has no zeros. However, (2.3.11) actually defines  $y$  for all  $x$ , and differentiating (2.3.11) shows that

$$y' = \frac{10}{3}x(x^2 + c)^{2/3} = \frac{10}{3}xy^{2/5}, \quad -\infty < x < \infty.$$



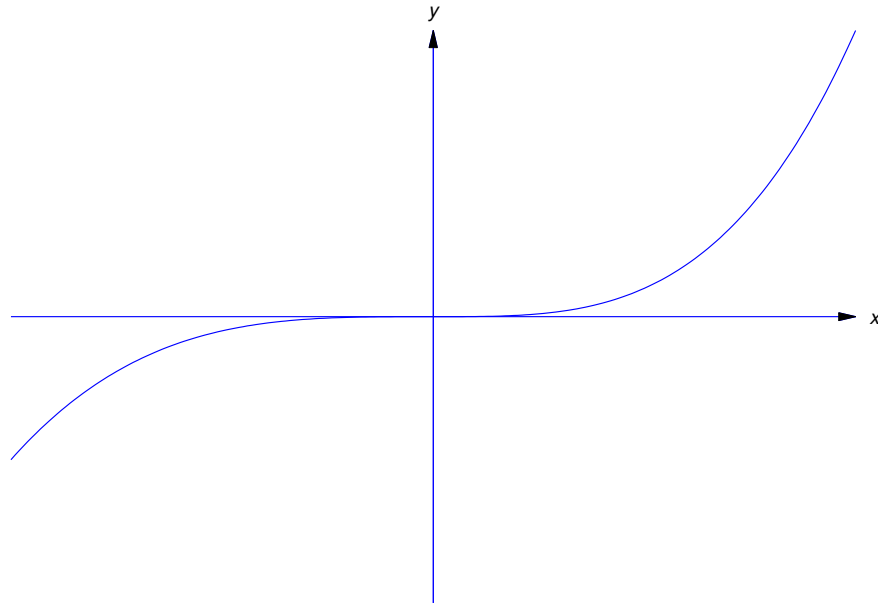

Figure 2.3.2 Two solutions ( $y = 0$  and  $y = x^{1/2}$ ) of (2.3.9) that differ on every interval containing  $x_0 = 0$

Therefore (2.3.11) satisfies (2.3.10) on  $(-\infty, \infty)$  even if  $c \leq 0$ , so that  $y(\sqrt{|c|}) = y(-\sqrt{|c|}) = 0$ . In particular, taking  $c = 0$  in (2.3.11) yields

$$y = x^{10/3}$$

as a second solution of (2.3.9). Both solutions are defined on  $(-\infty, \infty)$ , and they differ on every open interval that contains  $x_0 = 0$  (see Figure 2.3.2.) In fact, there are *four* distinct solutions of (2.3.9) defined on  $(-\infty, \infty)$  that differ from each other on every open interval that contains  $x_0 = 0$ . Can you identify the other two?

**Example 2.3.7** From Example 2.3.5, the initial value problem

$$y' = \frac{10}{3}xy^{2/5}, \quad y(0) = -1 \tag{2.3.12}$$

has a unique solution on some open interval that contains  $x_0 = 0$ . Find a solution and determine the largest open interval  $(a, b)$  on which it's unique.

**Solution** Let  $y$  be any solution of (2.3.12). Because of the initial condition  $y(0) = -1$  and the continuity of  $y$ , there's an open interval  $I$  that contains  $x_0 = 0$  on which  $y$  has no zeros, and is consequently of the form (2.3.11). Setting  $x = 0$  and  $y = -1$  in (2.3.11) yields  $c = -1$ , so

$$y = (x^2 - 1)^{5/3} \tag{2.3.13}$$

for  $x$  in  $I$ . Therefore every solution of (2.3.12) differs from zero and is given by (2.3.13) on  $(-1, 1)$ ; that is, (2.3.13) is the unique solution of (2.3.12) on  $(-1, 1)$ . This is the largest open interval on which (2.3.12) has a unique solution. To see this, note that (2.3.13) is a solution of (2.3.12) on  $(-\infty, \infty)$ . From

Exercise 2.2.15, there are infinitely many other solutions of (2.3.12) that differ from (2.3.13) on every open interval larger than  $(-1, 1)$ . One such solution is

$$y = \begin{cases} (x^2 - 1)^{5/3}, & -1 \leq x \leq 1, \\ 0, & |x| > 1. \end{cases}$$

(Figure 2.3.3).

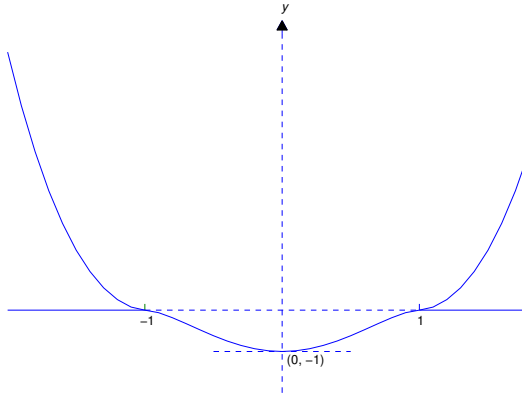

Figure 2.3.3 Two solutions of (2.3.12) on  $(-\infty, \infty)$  that coincide on  $(-1, 1)$ , but on no larger open interval

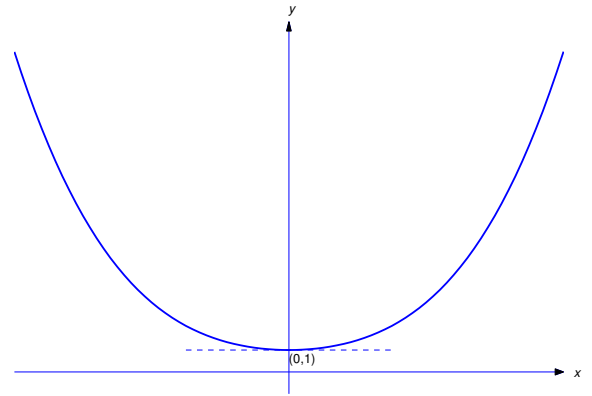

Figure 2.3.4 The unique solution of (2.3.14)

**Example 2.3.8** From Example 2.3.5, the initial value problem

$$y' = \frac{10}{3}xy^{2/5}, \quad y(0) = 1 \quad (2.3.14)$$

has a unique solution on some open interval that contains  $x_0 = 0$ . Find the solution and determine the largest open interval on which it's unique.

**Solution** Let  $y$  be any solution of (2.3.14). Because of the initial condition  $y(0) = 1$  and the continuity of  $y$ , there's an open interval  $I$  that contains  $x_0 = 0$  on which  $y$  has no zeros, and is consequently of the form (2.3.11). Setting  $x = 0$  and  $y = 1$  in (2.3.11) yields  $c = 1$ , so

$$y = (x^2 + 1)^{5/3} \quad (2.3.15)$$

for  $x$  in  $I$ . Therefore every solution of (2.3.14) differs from zero and is given by (2.3.15) on  $(-\infty, \infty)$ ; that is, (2.3.15) is the unique solution of (2.3.14) on  $(-\infty, \infty)$ . Figure 2.3.4 shows the graph of this solution.

## 2.3 Exercises

In Exercises 1-13 find all  $(x_0, y_0)$  for which Theorem 2.3.1 implies that the initial value problem  $y' = f(x, y)$ ,  $y(x_0) = y_0$  has (a) a solution (b) a unique solution on some open interval that contains  $x_0$ .

1.  $y' = \frac{x^2 + y^2}{\sin x}$
2.  $y' = \frac{e^x + y}{x^2 + y^2}$
3.  $y' = \tan xy$
4.  $y' = \frac{x^2 + y^2}{\ln xy}$
5.  $y' = (x^2 + y^2)y^{1/3}$
6.  $y' = 2xy$
7.  $y' = \ln(1 + x^2 + y^2)$
8.  $y' = \frac{2x + 3y}{x - 4y}$
9.  $y' = (x^2 + y^2)^{1/2}$
10.  $y' = x(y^2 - 1)^{2/3}$
11.  $y' = (x^2 + y^2)^2$
12.  $y' = (x + y)^{1/2}$
13.  $y' = \frac{\tan y}{x - 1}$
14. Apply Theorem 2.3.1 to the initial value problem

$$y' + p(x)y = q(x), \quad y(x_0) = y_0$$

for a linear equation, and compare the conclusions that can be drawn from it to those that follow from Theorem 2.1.2.

15. (a) Verify that the function

$$y = \begin{cases} (x^2 - 1)^{5/3}, & -1 < x < 1, \\ 0, & |x| \geq 1, \end{cases}$$

is a solution of the initial value problem

$$y' = \frac{10}{3}xy^{2/5}, \quad y(0) = -1$$

on  $(-\infty, \infty)$ . HINT: You'll need the definition

$$y'(\bar{x}) = \lim_{x \rightarrow \bar{x}} \frac{y(x) - y(\bar{x})}{x - \bar{x}}$$

to verify that  $y$  satisfies the differential equation at  $\bar{x} = \pm 1$ .

- (b) Verify that if  $\epsilon_i = 0$  or 1 for  $i = 1, 2$  and  $a, b > 1$ , then the function

$$y = \begin{cases} \epsilon_1(x^2 - a^2)^{5/3}, & -\infty < x < -a, \\ 0, & -a \leq x \leq -1, \\ (x^2 - 1)^{5/3}, & -1 < x < 1, \\ 0, & 1 \leq x \leq b, \\ \epsilon_2(x^2 - b^2)^{5/3}, & b < x < \infty, \end{cases}$$

is a solution of the initial value problem of (a) on  $(-\infty, \infty)$ .

16. Use the ideas developed in Exercise 15 to find infinitely many solutions of the initial value problem

$$y' = y^{2/5}, \quad y(0) = 1$$

on  $(-\infty, \infty)$ .

17. Consider the initial value problem

$$y' = 3x(y - 1)^{1/3}, \quad y(x_0) = y_0. \quad (\text{A})$$

- (a) For what points  $(x_0, y_0)$  does Theorem 2.3.1 imply that (A) has a solution?  
 (b) For what points  $(x_0, y_0)$  does Theorem 2.3.1 imply that (A) has a unique solution on some open interval that contains  $x_0$ ?

18. Find nine solutions of the initial value problem

$$y' = 3x(y - 1)^{1/3}, \quad y(0) = 1$$

that are all defined on  $(-\infty, \infty)$  and differ from each other for values of  $x$  in every open interval that contains  $x_0 = 0$ .

19. From Theorem 2.3.1, the initial value problem

$$y' = 3x(y - 1)^{1/3}, \quad y(0) = 9$$

has a unique solution on an open interval that contains  $x_0 = 0$ . Find the solution and determine the largest open interval on which it's unique.

20. (a) From Theorem 2.3.1, the initial value problem

$$y' = 3x(y - 1)^{1/3}, \quad y(3) = -7 \quad (\text{A})$$

has a unique solution on some open interval that contains  $x_0 = 3$ . Determine the largest such open interval, and find the solution on this interval.

- (b) Find infinitely many solutions of (A), all defined on  $(-\infty, \infty)$ .

21. Prove:

- (a) If

$$f(x, y_0) = 0, \quad a < x < b, \quad (\text{A})$$

and  $x_0$  is in  $(a, b)$ , then  $y \equiv y_0$  is a solution of

$$y' = f(x, y), \quad y(x_0) = y_0$$

on  $(a, b)$ .

- (b) If  $f$  and  $f_y$  are continuous on an open rectangle that contains  $(x_0, y_0)$  and (A) holds, no solution of  $y' = f(x, y)$  other than  $y \equiv y_0$  can equal  $y_0$  at any point in  $(a, b)$ .

## 2.4 TRANSFORMATION OF NONLINEAR EQUATIONS INTO SEPARABLE EQUATIONS

In Section 2.1 we found that the solutions of a linear nonhomogeneous equation

$$y' + p(x)y = f(x)$$

are of the form  $y = uy_1$ , where  $y_1$  is a nontrivial solution of the complementary equation

$$y' + p(x)y = 0 \quad (2.4.1)$$

and  $u$  is a solution of

$$u'y_1(x) = f(x).$$

Note that this last equation is separable, since it can be rewritten as

$$u' = \frac{f(x)}{y_1(x)}.$$

In this section we'll consider nonlinear differential equations that are not separable to begin with, but can be solved in a similar fashion by writing their solutions in the form  $y = uy_1$ , where  $y_1$  is a suitably chosen known function and  $u$  satisfies a separable equation. We'll say in this case that we *transformed* the given equation into a separable equation.

### Bernoulli Equations

A *Bernoulli equation* is an equation of the form

$$y' + p(x)y = f(x)y^r, \quad (2.4.2)$$

where  $r$  can be any real number other than 0 or 1. (Note that (2.4.2) is linear if and only if  $r = 0$  or  $r = 1$ .) We can transform (2.4.2) into a separable equation by variation of parameters: if  $y_1$  is a nontrivial solution of (2.4.1), substituting  $y = uy_1$  into (2.4.2) yields

$$u'y_1 + u(y_1' + p(x)y_1) = f(x)(uy_1)^r,$$

which is equivalent to the separable equation

$$u'y_1(x) = f(x)(y_1(x))^r u^r \quad \text{or} \quad \frac{u'}{u^r} = f(x)(y_1(x))^{r-1},$$

since  $y_1' + p(x)y_1 = 0$ .

**Example 2.4.1** Solve the Bernoulli equation

$$y' - y = xy^2. \quad (2.4.3)$$

**Solution** Since  $y_1 = e^x$  is a solution of  $y' - y = 0$ , we look for solutions of (2.4.3) in the form  $y = ue^x$ , where

$$u'e^x = xu^2e^{2x} \quad \text{or, equivalently,} \quad u' = xu^2e^x.$$

Separating variables yields

$$\frac{u'}{u^2} = xe^x,$$

and integrating yields

$$-\frac{1}{u} = (x-1)e^x + c.$$

Hence,

$$u = -\frac{1}{(x-1)e^x + c}$$

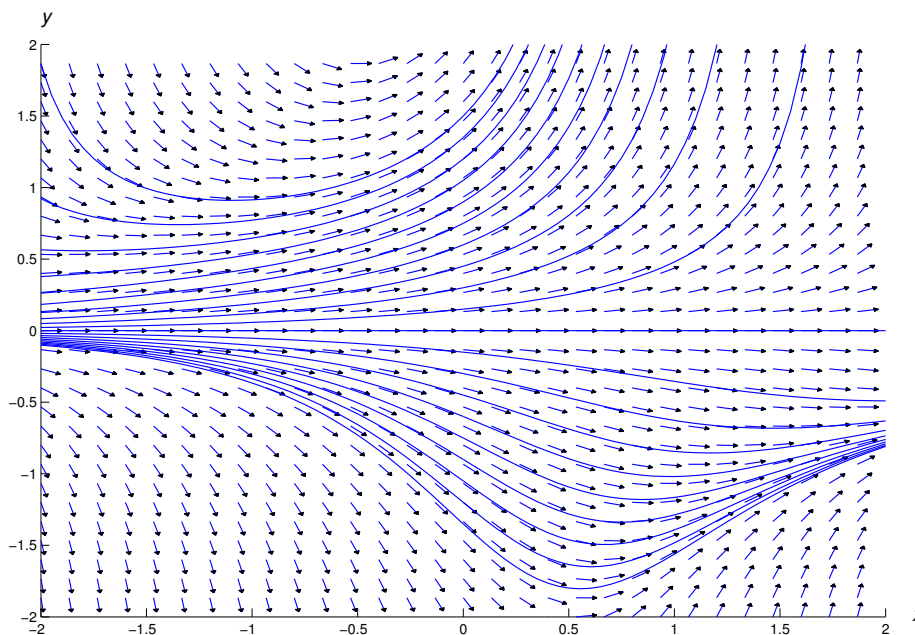

Figure 2.4.1 A direction field and integral curves for  $y' - y = xy^2$

and

$$y = -\frac{1}{x - 1 + ce^{-x}}.$$

Figure 2.4.1 shows direction field and some integral curves of (2.4.3).

### Other Nonlinear Equations That Can be Transformed Into Separable Equations

We've seen that the nonlinear Bernoulli equation can be transformed into a separable equation by the substitution  $y = uy_1$  if  $y_1$  is suitably chosen. Now let's discover a sufficient condition for a nonlinear first order differential equation

$$y' = f(x, y) \tag{2.4.4}$$

to be transformable into a separable equation in the same way. Substituting  $y = uy_1$  into (2.4.4) yields

$$u'y_1(x) + uy_1'(x) = f(x, uy_1(x)),$$

which is equivalent to

$$u'y_1(x) = f(x, uy_1(x)) - uy_1'(x). \tag{2.4.5}$$

If

$$f(x, uy_1(x)) = q(u)y_1'(x)$$

for some function  $q$ , then (2.4.5) becomes

$$u'y_1(x) = (q(u) - u)y_1'(x), \tag{2.4.6}$$

which is separable. After checking for constant solutions  $u \equiv u_0$  such that  $q(u_0) = u_0$ , we can separate variables to obtain

$$\frac{u'}{q(u) - u} = \frac{y_1'(x)}{y_1(x)}.$$

### Homogeneous Nonlinear Equations

In the text we'll consider only the most widely studied class of equations for which the method of the preceding paragraph works. Other types of equations appear in Exercises 44–51.

The differential equation (2.4.4) is said to be *homogeneous* if  $x$  and  $y$  occur in  $f$  in such a way that  $f(x, y)$  depends only on the ratio  $y/x$ ; that is, (2.4.4) can be written as

$$y' = q(y/x), \quad (2.4.7)$$

where  $q = q(u)$  is a function of a single variable. For example,

$$y' = \frac{y + xe^{-y/x}}{x} = \frac{y}{x} + e^{-y/x}$$

and

$$y' = \frac{y^2 + xy - x^2}{x^2} = \left(\frac{y}{x}\right)^2 + \frac{y}{x} - 1$$

are of the form (2.4.7), with

$$q(u) = u + e^{-u} \quad \text{and} \quad q(u) = u^2 + u - 1,$$

respectively. The general method discussed above can be applied to (2.4.7) with  $y_1 = x$  (and therefore  $y'_1 = 1$ ). Thus, substituting  $y = ux$  in (2.4.7) yields

$$u'x + u = q(u),$$

and separation of variables (after checking for constant solutions  $u \equiv u_0$  such that  $q(u_0) = u_0$ ) yields

$$\frac{u'}{q(u) - u} = \frac{1}{x}.$$

Before turning to examples, we point out something that you may've have already noticed: the definition of *homogeneous equation* given here isn't the same as the definition given in Section 2.1, where we said that a linear equation of the form

$$y' + p(x)y = 0$$

is homogeneous. We make no apology for this inconsistency, since we didn't create it historically, *homogeneous* has been used in these two inconsistent ways. The one having to do with linear equations is the most important. This is the only section of the book where the meaning defined here will apply.

Since  $y/x$  is in general undefined if  $x = 0$ , we'll consider solutions of nonhomogeneous equations only on open intervals that do not contain the point  $x = 0$ .

**Example 2.4.2** Solve

$$y' = \frac{y + xe^{-y/x}}{x}. \quad (2.4.8)$$

**Solution** Substituting  $y = ux$  into (2.4.8) yields

$$u'x + u = \frac{ux + xe^{-ux/x}}{x} = u + e^{-u}.$$

Simplifying and separating variables yields

$$e^u u' = \frac{1}{x}.$$

Integrating yields  $e^u = \ln|x| + c$ . Therefore  $u = \ln(\ln|x| + c)$  and  $y = ux = x \ln(\ln|x| + c)$ .

Figure 2.4.2 shows a direction field and integral curves for (2.4.8).

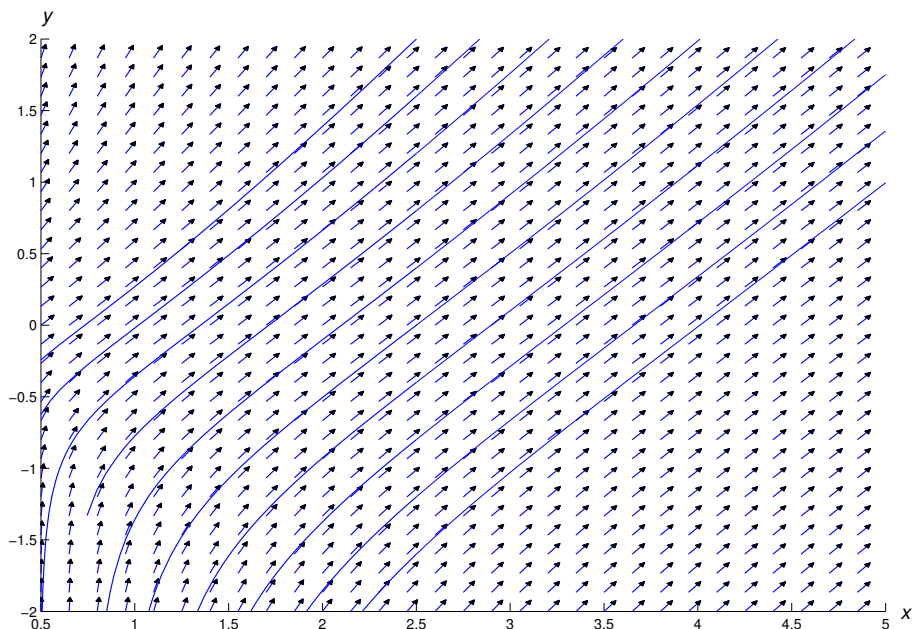

Figure 2.4.2 A direction field and some integral curves for  $y' = \frac{y + xe^{-y/x}}{x}$

### Example 2.4.3

(a) Solve

$$x^2 y' = y^2 + xy - x^2. \quad (2.4.9)$$

(b) Solve the initial value problem

$$x^2 y' = y^2 + xy - x^2, \quad y(1) = 2. \quad (2.4.10)$$

**SOLUTION(a)** We first find solutions of (2.4.9) on open intervals that don't contain  $x = 0$ . We can rewrite (2.4.9) as

$$y' = \frac{y^2 + xy - x^2}{x^2}$$

for  $x$  in any such interval. Substituting  $y = ux$  yields

$$u'x + u = \frac{(ux)^2 + x(ux) - x^2}{x^2} = u^2 + u - 1,$$

so

$$u'x = u^2 - 1. \quad (2.4.11)$$



By inspection this equation has the constant solutions  $u \equiv 1$  and  $u \equiv -1$ . Therefore  $y = x$  and  $y = -x$  are solutions of (2.4.9). If  $u$  is a solution of (2.4.11) that doesn't assume the values  $\pm 1$  on some interval, separating variables yields

$$\frac{u'}{u^2 - 1} = \frac{1}{x},$$

or, after a partial fraction expansion,

$$\frac{1}{2} \left[ \frac{1}{u-1} - \frac{1}{u+1} \right] u' = \frac{1}{x}.$$

Multiplying by 2 and integrating yields

$$\ln \left| \frac{u-1}{u+1} \right| = 2 \ln |x| + k,$$

or

$$\left| \frac{u-1}{u+1} \right| = e^k x^2,$$

which holds if

$$\frac{u-1}{u+1} = cx^2 \tag{2.4.12}$$

where  $c$  is an arbitrary constant. Solving for  $u$  yields

$$u = \frac{1 + cx^2}{1 - cx^2}.$$

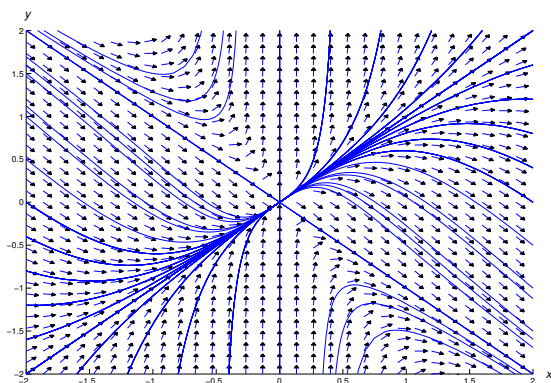

Figure 2.4.3 A direction field and integral curves for  $x^2 y' = y^2 + xy - x^2$

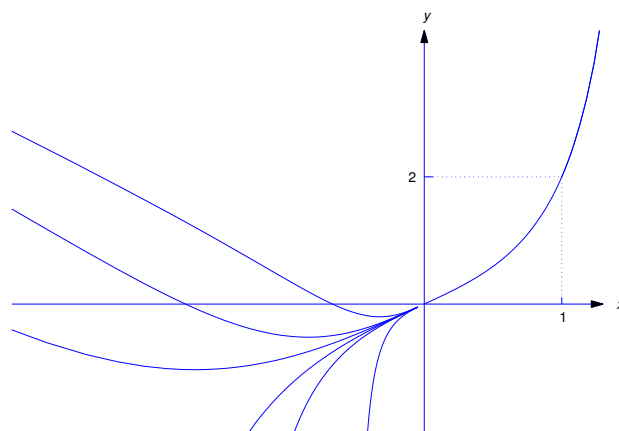

Figure 2.4.4 Solutions of  $x^2 y' = y^2 + xy - x^2$ ,  $y(1) = 2$

Therefore

$$y = ux = \frac{x(1 + cx^2)}{1 - cx^2} \tag{2.4.13}$$

is a solution of (2.4.10) for any choice of the constant  $c$ . Setting  $c = 0$  in (2.4.13) yields the solution  $y = x$ . However, the solution  $y = -x$  can't be obtained from (2.4.13). Thus, the solutions of (2.4.9) on intervals that don't contain  $x = 0$  are  $y = -x$  and functions of the form (2.4.13).

The situation is more complicated if  $x = 0$  is the open interval. First, note that  $y = -x$  satisfies (2.4.9) on  $(-\infty, \infty)$ . If  $c_1$  and  $c_2$  are arbitrary constants, the function

$$y = \begin{cases} \frac{x(1 + c_1 x^2)}{1 - c_1 x^2}, & a < x < 0, \\ \frac{x(1 + c_2 x^2)}{1 - c_2 x^2}, & 0 \leq x < b, \end{cases} \quad (2.4.14)$$

is a solution of (2.4.9) on  $(a, b)$ , where

$$a = \begin{cases} -\frac{1}{\sqrt{c_1}} & \text{if } c_1 > 0, \\ -\infty & \text{if } c_1 \leq 0, \end{cases} \quad \text{and} \quad b = \begin{cases} \frac{1}{\sqrt{c_2}} & \text{if } c_2 > 0, \\ \infty & \text{if } c_2 \leq 0. \end{cases}$$

We leave it to you to verify this. To do so, note that if  $y$  is any function of the form (2.4.13) then  $y(0) = 0$  and  $y'(0) = 1$ .

Figure 2.4.3 shows a direction field and some integral curves for (2.4.9).

**SOLUTION(b)** We could obtain  $c$  by imposing the initial condition  $y(1) = 2$  in (2.4.13), and then solving for  $c$ . However, it's easier to use (2.4.12). Since  $u = y/x$ , the initial condition  $y(1) = 2$  implies that  $u(1) = 2$ . Substituting this into (2.4.12) yields  $c = 1/3$ . Hence, the solution of (2.4.10) is

$$y = \frac{x(1 + x^2/3)}{1 - x^2/3}.$$

The interval of validity of this solution is  $(-\sqrt{3}, \sqrt{3})$ . However, the largest interval on which (2.4.10) has a unique solution is  $(0, \sqrt{3})$ . To see this, note from (2.4.14) that any function of the form

$$y = \begin{cases} \frac{x(1 + cx^2)}{1 - cx^2}, & a < x \leq 0, \\ \frac{x(1 + x^2/3)}{1 - x^2/3}, & 0 \leq x < \sqrt{3}, \end{cases} \quad (2.4.15)$$

is a solution of (2.4.10) on  $(a, \sqrt{3})$ , where  $a = -1/\sqrt{c}$  if  $c > 0$  or  $a = -\infty$  if  $c \leq 0$ . (Why doesn't this contradict Theorem 2.3.1?)

Figure 2.4.4 shows several solutions of the initial value problem (2.4.10). Note that these solutions coincide on  $(0, \sqrt{3})$ .

In the last two examples we were able to solve the given equations explicitly. However, this isn't always possible, as you'll see in the exercises.

## 2.4 Exercises

In Exercises 1–4 solve the given Bernoulli equation.

- |                                   |   |
|-----------------------------------|---|
| 1. $y' + y = y^2$                 | 2. $7xy' - 2y = -\frac{x^2}{y^6}$             |
| 3. $x^2y' + 2y = 2e^{1/x}y^{1/2}$ | 4. $(1 + x^2)y' + 2xy = \frac{1}{(1 + x^2)y}$ |

In Exercises 5 and 6 find all solutions. Also, plot a direction field and some integral curves on the indicated rectangular region.

5. C/G  $y' - xy = x^3y^3; \quad \{-3 \leq x \leq 3, 2 \leq y \leq 2\}$   
 6. C/G  $y' - \frac{1+x}{3x}y = y^4; \quad \{-2 \leq x \leq 2, -2 \leq y \leq 2\}$

In Exercises 7–11 solve the initial value problem.

7.  $y' - 2y = xy^3, \quad y(0) = 2\sqrt{2}$   
 8.  $y' - xy = xy^{3/2}, \quad y(1) = 4$   
 9.  $xy' + y = x^4y^4, \quad y(1) = 1/2$   
 10.  $y' - 2y = 2y^{1/2}, \quad y(0) = 1$   
 11.  $y' - 4y = \frac{48x}{y^2}, \quad y(0) = 1$

In Exercises 12 and 13 solve the initial value problem and graph the solution.

12. C/G  $x^2y' + 2xy = y^3, \quad y(1) = 1/\sqrt{2}$   
 13. C/G  $y' - y = xy^{1/2}, \quad y(0) = 4$   
 14. You may have noticed that the logistic equation

$$P' = aP(1 - \alpha P)$$

from Verhulst's model for population growth can be written in Bernoulli form as

$$P' - aP = -a\alpha P^2.$$

This isn't particularly interesting, since the logistic equation is separable, and therefore solvable by the method studied in Section 2.2. So let's consider a more complicated model, where  $a$  is a positive constant and  $\alpha$  is a positive continuous function of  $t$  on  $[0, \infty)$ . The equation for this model is

$$P' - aP = -a\alpha(t)P^2,$$

a non-separable Bernoulli equation.

- (a) Assuming that  $P(0) = P_0 > 0$ , find  $P$  for  $t > 0$ . HINT: Express your result in terms of the integral  $\int_0^t \alpha(\tau)e^{a\tau} d\tau$ .  
 (b) Verify that your result reduces to the known results for the Malthusian model where  $\alpha = 0$ , and the Verhulst model where  $\alpha$  is a nonzero constant.  
 (c) Assuming that

$$\lim_{t \rightarrow \infty} e^{-at} \int_0^t \alpha(\tau)e^{a\tau} d\tau = L$$

exists (finite or infinite), find  $\lim_{t \rightarrow \infty} P(t)$ .

In Exercises 15–18 solve the equation explicitly.

15.  $y' = \frac{y+x}{x}$

16.  $y' = \frac{y^2 + 2xy}{x^2}$

17.  $xy^3y' = y^4 + x^4$

18.  $y' = \frac{y}{x} + \sec \frac{y}{x}$

In Exercises 19–21 solve the equation explicitly. Also, plot a direction field and some integral curves on the indicated rectangular region.

19. C/G  $x^2y' = xy + x^2 + y^2; \quad \{-8 \leq x \leq 8, -8 \leq y \leq 8\}$

20. C/G  $xyy' = x^2 + 2y^2; \quad \{-4 \leq x \leq 4, -4 \leq y \leq 4\}$

21. C/G  $y' = \frac{2y^2 + x^2e^{-(y/x)^2}}{2xy}; \quad \{-8 \leq x \leq 8, -8 \leq y \leq 8\}$

In Exercises 22–27 solve the initial value problem.

22.  $y' = \frac{xy + y^2}{x^2}, \quad y(-1) = 2$

23.  $y' = \frac{x^3 + y^3}{xy^2}, \quad y(1) = 3$

24.  $xyy' + x^2 + y^2 = 0, \quad y(1) = 2$

25.  $y' = \frac{y^2 - 3xy - 5x^2}{x^2}, \quad y(1) = -1$

26.  $x^2y' = 2x^2 + y^2 + 4xy, \quad y(1) = 1$

27.  $xyy' = 3x^2 + 4y^2, \quad y(1) = \sqrt{3}$

In Exercises 28–34 solve the given homogeneous equation implicitly.

28.  $y' = \frac{x + y}{x - y}$

29.  $(y'x - y)(\ln |y| - \ln |x|) = x$

30.  $y' = \frac{y^3 + 2xy^2 + x^2y + x^3}{x(y + x)^2}$

31.  $y' = \frac{x + 2y}{2x + y}$

32.  $y' = \frac{y}{y - 2x}$

33.  $y' = \frac{xy^2 + 2y^3}{x^3 + x^2y + xy^2}$

34.  $y' = \frac{x^3 + x^2y + 3y^3}{x^3 + 3xy^2}$

35. L

(a) Find a solution of the initial value problem

$$x^2y' = y^2 + xy - 4x^2, \quad y(-1) = 0 \quad (\text{A})$$

on the interval  $(-\infty, 0)$ . Verify that this solution is actually valid on  $(-\infty, \infty)$ .

(b) Use Theorem 2.3.1 to show that (A) has a unique solution on  $(-\infty, 0)$ .

(c) Plot a direction field for the differential equation in (A) on a square

$$\{-r \leq x \leq r, -r \leq y \leq r\},$$

where  $r$  is any positive number. Graph the solution you obtained in (a) on this field.

(d) Graph other solutions of (A) that are defined on  $(-\infty, \infty)$ .

- (e) Graph other solutions of (A) that are defined only on intervals of the form  $(-\infty, a)$ , where  $a$  is a finite positive number.

36. L

- (a) Solve the equation

$$xyy' = x^2 - xy + y^2 \quad (\text{A})$$

implicitly.

- (b) Plot a direction field for (A) on a square

$$\{0 \leq x \leq r, 0 \leq y \leq r\}$$

where  $r$  is any positive number.

- (c) Let  $K$  be a positive integer. (You may have to try several choices for  $K$ .) Graph solutions of the initial value problems

$$xyy' = x^2 - xy + y^2, \quad y(r/2) = \frac{kr}{K},$$

for  $k = 1, 2, \dots, K$ . Based on your observations, find conditions on the positive numbers  $x_0$  and  $y_0$  such that the initial value problem

$$xyy' = x^2 - xy + y^2, \quad y(x_0) = y_0, \quad (\text{B})$$

has a unique solution (i) on  $(0, \infty)$  or (ii) only on an interval  $(a, \infty)$ , where  $a > 0$ ?

- (d) What can you say about the graph of the solution of (B) as  $x \rightarrow \infty$ ? (Again, assume that  $x_0 > 0$  and  $y_0 > 0$ .)

37. L

- (a) Solve the equation

$$y' = \frac{2y^2 - xy + 2x^2}{xy + 2x^2} \quad (\text{A})$$

implicitly.

- (b) Plot a direction field for (A) on a square

$$\{-r \leq x \leq r, -r \leq y \leq r\}$$

where  $r$  is any positive number. By graphing solutions of (A), determine necessary and sufficient conditions on  $(x_0, y_0)$  such that (A) has a solution on (i)  $(-\infty, 0)$  or (ii)  $(0, \infty)$  such that  $y(x_0) = y_0$ .

38. L Follow the instructions of Exercise 37 for the equation

$$y' = \frac{xy + x^2 + y^2}{xy}.$$

39. L Pick any nonlinear homogeneous equation  $y' = q(y/x)$  you like, and plot direction fields on the square  $\{-r \leq x \leq r, -r \leq y \leq r\}$ , where  $r > 0$ . What happens to the direction field as you vary  $r$ ? Why?

40. Prove: If  $ad - bc \neq 0$ , the equation

$$y' = \frac{ax + by + \alpha}{cx + dy + \beta}$$

can be transformed into the homogeneous nonlinear equation

$$\frac{dY}{dX} = \frac{aX + bY}{cX + dY}$$

by the substitution  $x = X - X_0$ ,  $y = Y - Y_0$ , where  $X_0$  and  $Y_0$  are suitably chosen constants.

In Exercises 41–43 use a method suggested by Exercise 40 to solve the given equation implicitly.

41.  $y' = \frac{-6x + y - 3}{2x - y - 1}$

42.  $y' = \frac{2x + y + 1}{x + 2y - 4}$

43.  $y' = \frac{-x + 3y - 14}{x + y - 2}$

In Exercises 44–51 find a function  $y_1$  such that the substitution  $y = uy_1$  transforms the given equation into a separable equation of the form (2.4.6). Then solve the given equation explicitly.

44.  $3xy^2y' = y^3 + x$

45.  $xyy' = 3x^6 + 6y^2$

46.  $x^3y' = 2(y^2 + x^2y - x^4)$

47.  $y' = y^2e^{-x} + 4y + 2e^x$

48.  $y' = \frac{y^2 + y \tan x + \tan^2 x}{\sin^2 x}$

49.  $x(\ln x)^2y' = -4(\ln x)^2 + y \ln x + y^2$

50.  $2x(y + 2\sqrt{x})y' = (y + \sqrt{x})^2$

51.  $(y + e^{x^2})y' = 2x(y^2 + ye^{x^2} + e^{2x^2})$

52. Solve the initial value problem

$$y' + \frac{2}{x}y = \frac{3x^2y^2 + 6xy + 2}{x^2(2xy + 3)}, \quad y(2) = 2.$$

53. Solve the initial value problem

$$y' + \frac{3}{x}y = \frac{3x^4y^2 + 10x^2y + 6}{x^3(2x^2y + 5)}, \quad y(1) = 1.$$

54. Prove: If  $y$  is a solution of a homogeneous nonlinear equation  $y' = q(y/x)$ , so is  $y_1 = y(ax)/a$ , where  $a$  is any nonzero constant.

55. A *generalized Riccati equation* is of the form

$$y' = P(x) + Q(x)y + R(x)y^2. \quad (\text{A})$$

(If  $R \equiv -1$ , (A) is a *Riccati equation*.) Let  $y_1$  be a known solution and  $y$  an arbitrary solution of (A). Let  $z = y - y_1$ . Show that  $z$  is a solution of a Bernoulli equation with  $n = 2$ .

In Exercises 56–59, given that  $y_1$  is a solution of the given equation, use the method suggested by Exercise 55 to find other solutions.

56.  $y' = 1 + x - (1 + 2x)y + xy^2; \quad y_1 = 1$

57.  $y' = e^{2x} + (1 - 2e^x)y + y^2; \quad y_1 = e^x$

58.  $xy' = 2 - x + (2x - 2)y - xy^2; \quad y_1 = 1$

59.  $xy' = x^3 + (1 - 2x^2)y + xy^2; \quad y_1 = x$

## 2.5 EXACT EQUATIONS

In this section it's convenient to write first order differential equations in the form

$$M(x, y) dx + N(x, y) dy = 0. \quad (2.5.1)$$

This equation can be interpreted as

$$M(x, y) + N(x, y) \frac{dy}{dx} = 0, \quad (2.5.2)$$

where  $x$  is the independent variable and  $y$  is the dependent variable, or as

$$M(x, y) \frac{dx}{dy} + N(x, y) = 0, \quad (2.5.3)$$

where  $y$  is the independent variable and  $x$  is the dependent variable. Since the solutions of (2.5.2) and (2.5.3) will often have to be left in implicit form we'll say that  $F(x, y) = c$  is an implicit solution of (2.5.1) if every differentiable function  $y = y(x)$  that satisfies  $F(x, y) = c$  is a solution of (2.5.2) and every differentiable function  $x = x(y)$  that satisfies  $F(x, y) = c$  is a solution of (2.5.3).

Here are some examples:

Equation (2.5.1)	Equation (2.5.2)	Equation (2.5.3)
$3x^2y^2 dx + 2x^3y dy = 0$	$3x^2y^2 + 2x^3y \frac{dy}{dx} = 0$	$3x^2y^2 \frac{dx}{dy} + 2x^3y = 0$
$(x^2 + y^2) dx + 2xy dy = 0$	$(x^2 + y^2) + 2xy \frac{dy}{dx} = 0$	$(x^2 + y^2) \frac{dx}{dy} + 2xy = 0$
$3y \sin x dx - 2xy \cos x dy = 0$	$3y \sin x - 2xy \cos x \frac{dy}{dx} = 0$	$3y \sin x \frac{dx}{dy} - 2xy \cos x = 0$

Note that a separable equation can be written as (2.5.1) as

$$M(x) dx + N(y) dy = 0.$$

We'll develop a method for solving (2.5.1) under appropriate assumptions on  $M$  and  $N$ . This method is an extension of the method of separation of variables (Exercise 41). Before stating it we consider an example.

**Example 2.5.1** Show that

$$x^4y^3 + x^2y^5 + 2xy = c \quad (2.5.4)$$

is an implicit solution of

$$(4x^3y^3 + 2xy^5 + 2y) dx + (3x^4y^2 + 5x^2y^4 + 2x) dy = 0. \quad (2.5.5)$$

**Solution** Regarding  $y$  as a function of  $x$  and differentiating (2.5.4) implicitly with respect to  $x$  yields

$$(4x^3y^3 + 2xy^5 + 2y) + (3x^4y^2 + 5x^2y^4 + 2x) \frac{dy}{dx} = 0.$$

Similarly, regarding  $x$  as a function of  $y$  and differentiating (2.5.4) implicitly with respect to  $y$  yields

$$(4x^3y^3 + 2xy^5 + 2y) \frac{dx}{dy} + (3x^4y^2 + 5x^2y^4 + 2x) = 0.$$

Therefore (2.5.4) is an implicit solution of (2.5.5) in either of its two possible interpretations. ■

You may think this example is pointless, since concocting a differential equation that has a given implicit solution isn't particularly interesting. However, it illustrates the next important theorem, which we'll prove by using implicit differentiation, as in Example 2.5.1.

**Theorem 2.5.1** *If  $F = F(x, y)$  has continuous partial derivatives  $F_x$  and  $F_y$ , then*

$$F(x, y) = c \quad (c=\text{constant}), \quad (2.5.6)$$

*is an implicit solution of the differential equation*

$$F_x(x, y) dx + F_y(x, y) dy = 0. \quad (2.5.7)$$

**Proof** Regarding  $y$  as a function of  $x$  and differentiating (2.5.6) implicitly with respect to  $x$  yields

$$F_x(x, y) + F_y(x, y) \frac{dy}{dx} = 0.$$

On the other hand, regarding  $x$  as a function of  $y$  and differentiating (2.5.6) implicitly with respect to  $y$  yields

$$F_x(x, y) \frac{dx}{dy} + F_y(x, y) = 0.$$

Thus, (2.5.6) is an implicit solution of (2.5.7) in either of its two possible interpretations. ■

We'll say that the equation

$$M(x, y) dx + N(x, y) dy = 0 \quad (2.5.8)$$

is *exact* on an open rectangle  $R$  if there's a function  $F = F(x, y)$  such  $F_x$  and  $F_y$  are continuous, and

$$F_x(x, y) = M(x, y) \quad \text{and} \quad F_y(x, y) = N(x, y) \quad (2.5.9)$$

for all  $(x, y)$  in  $R$ . This usage of "exact" is related to its usage in calculus, where the expression

$$F_x(x, y) dx + F_y(x, y) dy$$

(obtained by substituting (2.5.9) into the left side of (2.5.8)) is the *exact differential of  $F$* .

Example 2.5.1 shows that it's easy to solve (2.5.8) if it's exact *and* we know a function  $F$  that satisfies (2.5.9). The important questions are:



QUESTION 1. Given an equation (2.5.8), how can we determine whether it's exact?

QUESTION 2. If (2.5.8) is exact, how do we find a function  $F$  satisfying (2.5.9)?

To discover the answer to Question 1, assume that there's a function  $F$  that satisfies (2.5.9) on some open rectangle  $R$ , and in addition that  $F$  has continuous mixed partial derivatives  $F_{xy}$  and  $F_{yx}$ . Then a theorem from calculus implies that

$$F_{xy} = F_{yx}. \quad (2.5.10)$$

If  $F_x = M$  and  $F_y = N$ , differentiating the first of these equations with respect to  $y$  and the second with respect to  $x$  yields

$$F_{xy} = M_y \quad \text{and} \quad F_{yx} = N_x. \quad (2.5.11)$$

From (2.5.10) and (2.5.11), we conclude that a necessary condition for exactness is that  $M_y = N_x$ . This motivates the next theorem, which we state without proof.

**Theorem 2.5.2** [The Exactness Condition] *Suppose  $M$  and  $N$  are continuous and have continuous partial derivatives  $M_y$  and  $N_x$  on an open rectangle  $R$ . Then*

$$M(x, y) dx + N(x, y) dy = 0$$

*is exact on  $R$  if and only if*

$$M_y(x, y) = N_x(x, y) \quad (2.5.12)$$

*for all  $(x, y)$  in  $R$ .*

To help you remember the exactness condition, observe that the coefficients of  $dx$  and  $dy$  are differentiated in (2.5.12) with respect to the “opposite” variables; that is, the coefficient of  $dx$  is differentiated with respect to  $y$ , while the coefficient of  $dy$  is differentiated with respect to  $x$ .

**Example 2.5.2** Show that the equation

$$3x^2y dx + 4x^3 dy = 0$$

is not exact on any open rectangle.

**Solution** Here

$$M(x, y) = 3x^2y \quad \text{and} \quad N(x, y) = 4x^3$$

so

$$M_y(x, y) = 3x^2 \quad \text{and} \quad N_x(x, y) = 12x^2.$$

Therefore  $M_y = N_x$  on the line  $x = 0$ , but not on any open rectangle, so there's no function  $F$  such that  $F_x(x, y) = M(x, y)$  and  $F_y(x, y) = N(x, y)$  for all  $(x, y)$  on any open rectangle. ■

The next example illustrates two possible methods for finding a function  $F$  that satisfies the condition  $F_x = M$  and  $F_y = N$  if  $M dx + N dy = 0$  is exact.

**Example 2.5.3** Solve

$$(4x^3y^3 + 3x^2) dx + (3x^4y^2 + 6y^2) dy = 0. \quad (2.5.13)$$

**Solution** (Method 1) Here

$$M(x, y) = 4x^3y^3 + 3x^2, \quad N(x, y) = 3x^4y^2 + 6y^2,$$

and

$$M_y(x, y) = N_x(x, y) = 12x^3y^2$$

for all  $(x, y)$ . Therefore Theorem 2.5.2 implies that there's a function  $F$  such that

$$F_x(x, y) = M(x, y) = 4x^3y^3 + 3x^2 \quad (2.5.14)$$

and

$$F_y(x, y) = N(x, y) = 3x^4y^2 + 6y^2 \quad (2.5.15)$$

for all  $(x, y)$ . To find  $F$ , we integrate (2.5.14) with respect to  $x$  to obtain

$$F(x, y) = x^4y^3 + x^3 + \phi(y), \quad (2.5.16)$$

where  $\phi(y)$  is the “constant” of integration. (Here  $\phi$  is “constant” in that it's independent of  $x$ , the variable of integration.) If  $\phi$  is any differentiable function of  $y$  then  $F$  satisfies (2.5.14). To determine  $\phi$  so that  $F$  also satisfies (2.5.15), assume that  $\phi$  is differentiable and differentiate  $F$  with respect to  $y$ . This yields

$$F_y(x, y) = 3x^4y^2 + \phi'(y).$$

Comparing this with (2.5.15) shows that

$$\phi'(y) = 6y^2.$$

We integrate this with respect to  $y$  and take the constant of integration to be zero because we're interested only in finding *some*  $F$  that satisfies (2.5.14) and (2.5.15). This yields

$$\phi(y) = 2y^3.$$

Substituting this into (2.5.16) yields

$$F(x, y) = x^4y^3 + x^3 + 2y^3. \quad (2.5.17)$$

Now Theorem 2.5.1 implies that

$$x^4y^3 + x^3 + 2y^3 = c$$

is an implicit solution of (2.5.13). Solving this for  $y$  yields the explicit solution

$$y = \left( \frac{c - x^3}{2 + x^4} \right)^{1/3}.$$

**Solution** (Method 2) Instead of first integrating (2.5.14) with respect to  $x$ , we could begin by integrating (2.5.15) with respect to  $y$  to obtain

$$F(x, y) = x^4y^3 + 2y^3 + \psi(x), \quad (2.5.18)$$

where  $\psi$  is an arbitrary function of  $x$ . To determine  $\psi$ , we assume that  $\psi$  is differentiable and differentiate  $F$  with respect to  $x$ , which yields

$$F_x(x, y) = 4x^3y^3 + \psi'(x).$$

Comparing this with (2.5.14) shows that

$$\psi'(x) = 3x^2.$$

Integrating this and again taking the constant of integration to be zero yields

$$\psi(x) = x^3.$$

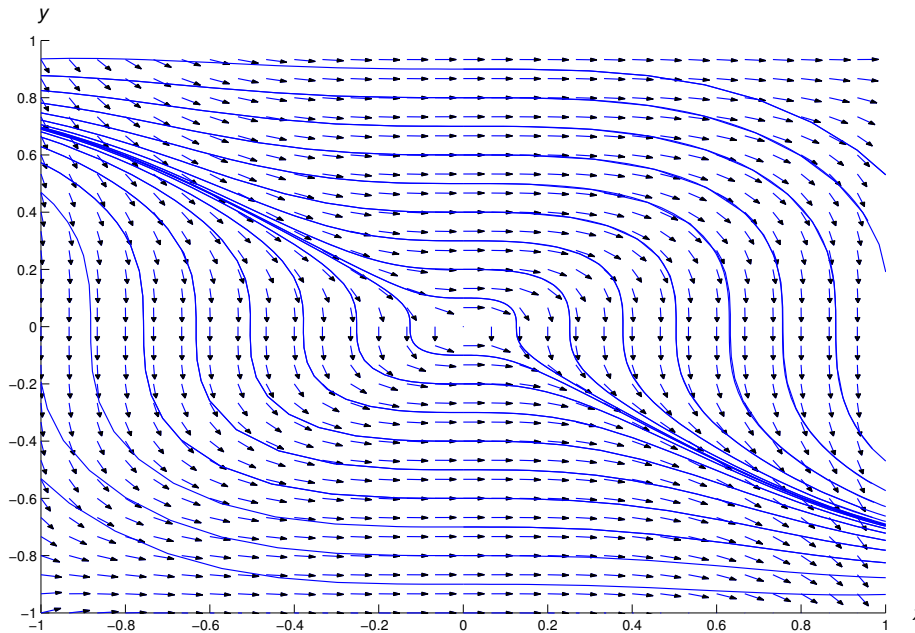

Figure 2.5.1 A direction field and integral curves for  $(4x^3y^3 + 3x^2) dx + (3x^4y^2 + 6y^2) dy = 0$

Substituting this into (2.5.18) yields (2.5.17).

Figure 2.5.1 shows a direction field and some integral curves of (2.5.13),

Here's a summary of the procedure used in Method 1 of this example. You should summarize procedure used in Method 2.

### Procedure For Solving An Exact Equation

**Step 1.** Check that the equation

$$M(x, y) dx + N(x, y) dy = 0 \quad (2.5.19)$$

satisfies the exactness condition  $M_y = N_x$ . If not, don't go further with this procedure.

**Step 2.** Integrate

$$\frac{\partial F(x, y)}{\partial x} = M(x, y)$$

with respect to  $x$  to obtain

$$F(x, y) = G(x, y) + \phi(y), \quad (2.5.20)$$

where  $G$  is an antiderivative of  $M$  with respect to  $x$ , and  $\phi$  is an unknown function of  $y$ .

**Step 3.** Differentiate (2.5.20) with respect to  $y$  to obtain

$$\frac{\partial F(x, y)}{\partial y} = \frac{\partial G(x, y)}{\partial y} + \phi'(y).$$

**Step 4.** Equate the right side of this equation to  $N$  and solve for  $\phi'$ ; thus,

$$\frac{\partial G(x, y)}{\partial y} + \phi'(y) = N(x, y), \quad \text{so} \quad \phi'(y) = N(x, y) - \frac{\partial G(x, y)}{\partial y}.$$

**Step 5.** Integrate  $\phi'$  with respect to  $y$ , taking the constant of integration to be zero, and substitute the result in (2.5.20) to obtain  $F(x, y)$ .

**Step 6.** Set  $F(x, y) = c$  to obtain an implicit solution of (2.5.19). If possible, solve for  $y$  explicitly as a function of  $x$ .

It's a common mistake to omit Step 6. However, it's important to include this step, since  $F$  isn't itself a solution of (2.5.19).

Many equations can be conveniently solved by either of the two methods used in Example 2.5.3. However, sometimes the integration required in one approach is more difficult than in the other. In such cases we choose the approach that requires the easier integration.

**Example 2.5.4** Solve the equation

$$(ye^{xy} \tan x + e^{xy} \sec^2 x) dx + xe^{xy} \tan x dy = 0. \quad (2.5.21)$$

**Solution** We leave it to you to check that  $M_y = N_x$  on any open rectangle where  $\tan x$  and  $\sec x$  are defined. Here we must find a function  $F$  such that

$$F_x(x, y) = ye^{xy} \tan x + e^{xy} \sec^2 x \quad (2.5.22)$$

and

$$F_y(x, y) = xe^{xy} \tan x. \quad (2.5.23)$$

It's difficult to integrate (2.5.22) with respect to  $x$ , but easy to integrate (2.5.23) with respect to  $y$ . This yields

$$F(x, y) = e^{xy} \tan x + \psi(x). \quad (2.5.24)$$

Differentiating this with respect to  $x$  yields

$$F_x(x, y) = ye^{xy} \tan x + e^{xy} \sec^2 x + \psi'(x).$$

Comparing this with (2.5.22) shows that  $\psi'(x) = 0$ . Hence,  $\psi$  is a constant, which we can take to be zero in (2.5.24), and

$$e^{xy} \tan x = c$$

is an implicit solution of (2.5.21). ■

Attempting to apply our procedure to an equation that isn't exact will lead to failure in Step 4, since the function

$$N - \frac{\partial G}{\partial y}$$

won't be independent of  $x$  if  $M_y \neq N_x$  (Exercise 31), and therefore can't be the derivative of a function of  $y$  alone. Here's an example that illustrates this.

**Example 2.5.5** Verify that the equation

$$3x^2y^2 dx + 6x^3y dy = 0 \quad (2.5.25)$$

is not exact, and show that the procedure for solving exact equations fails when applied to (2.5.25).

**Solution** Here

$$M_y(x, y) = 6x^2y \quad \text{and} \quad N_x(x, y) = 18x^2y,$$

so (2.5.25) isn't exact. Nevertheless, let's try to find a function  $F$  such that

$$F_x(x, y) = 3x^2y^2 \tag{2.5.26}$$

and

$$F_y(x, y) = 6x^3y. \tag{2.5.27}$$

Integrating (2.5.26) with respect to  $x$  yields

$$F(x, y) = x^3y^2 + \phi(y),$$

and differentiating this with respect to  $y$  yields

$$F_y(x, y) = 2x^3y + \phi'(y).$$

For this equation to be consistent with (2.5.27),

$$6x^3y = 2x^3y + \phi'(y),$$

or

$$\phi'(y) = 4x^3y.$$

This is a contradiction, since  $\phi'$  must be independent of  $x$ . Therefore the procedure fails.

## 2.5 Exercises

---

In Exercises 1–17 determine which equations are exact and solve them.

1.  $6x^2y^2 dx + 4x^3y dy = 0$
2.  $(3y \cos x + 4xe^x + 2x^2e^x) dx + (3 \sin x + 3) dy = 0$
3.  $14x^2y^3 dx + 21x^2y^2 dy = 0$
4.  $(2x - 2y^2) dx + (12y^2 - 4xy) dy = 0$
5.  $(x + y)^2 dx + (x + y)^2 dy = 0$
6.  $(4x + 7y) dx + (3x + 4y) dy = 0$
7.  $(-2y^2 \sin x + 3y^3 - 2x) dx + (4y \cos x + 9xy^2) dy = 0$
8.  $(2x + y) dx + (2y + 2x) dy = 0$
9.  $(3x^2 + 2xy + 4y^2) dx + (x^2 + 8xy + 18y) dy = 0$
10.  $(2x^2 + 8xy + y^2) dx + (2x^2 + xy^3/3) dy = 0$
11.  $\left(\frac{1}{x} + 2x\right) dx + \left(\frac{1}{y} + 2y\right) dy = 0$
12.  $(y \sin xy + xy^2 \cos xy) dx + (x \sin xy + xy^2 \cos xy) dy = 0$
13.  $\frac{x dx}{(x^2 + y^2)^{3/2}} + \frac{y dy}{(x^2 + y^2)^{3/2}} = 0$
14.  $(e^x(x^2y^2 + 2xy^2) + 6x) dx + (2x^2ye^x + 2) dy = 0$
15.  $(x^2e^{x^2+y}(2x^2 + 3) + 4x) dx + (x^3e^{x^2+y} - 12y^2) dy = 0$

16.  $(e^{xy}(x^4y + 4x^3) + 3y) dx + (x^5e^{xy} + 3x) dy = 0$   
 17.  $(3x^2 \cos xy - x^3y \sin xy + 4x) dx + (8y - x^4 \sin xy) dy = 0$

In Exercises 18–22 solve the initial value problem.

18.  $(4x^3y^2 - 6x^2y - 2x - 3) dx + (2x^4y - 2x^3) dy = 0, \quad y(1) = 3$   
 19.  $(-4y \cos x + 4 \sin x \cos x + \sec^2 x) dx + (4y - 4 \sin x) dy = 0, \quad y(\pi/4) = 0$   
 20.  $(y^3 - 1)e^x dx + 3y^2(e^x + 1) dy = 0, \quad y(0) = 0$   
 21.  $(\sin x - y \sin x - 2 \cos x) dx + \cos x dy = 0, \quad y(0) = 1$   
 22.  $(2x - 1)(y - 1) dx + (x + 2)(x - 3) dy = 0, \quad y(1) = -1$   
 23. **C/G** Solve the exact equation

$$(7x + 4y) dx + (4x + 3y) dy = 0.$$

Plot a direction field and some integral curves for this equation on the rectangle

$$\{-1 \leq x \leq 1, -1 \leq y \leq 1\}.$$

24. **C/G** Solve the exact equation

$$e^x(x^4y^2 + 4x^3y^2 + 1) dx + (2x^4ye^x + 2y) dy = 0.$$

Plot a direction field and some integral curves for this equation on the rectangle

$$\{-2 \leq x \leq 2, -1 \leq y \leq 1\}.$$

25. **C/G** Plot a direction field and some integral curves for the exact equation

$$(x^3y^4 + x) dx + (x^4y^3 + y) dy = 0$$

on the rectangle  $\{-1 \leq x \leq 1, -1 \leq y \leq 1\}$ . (See Exercise 37(a)).

26. **C/G** Plot a direction field and some integral curves for the exact equation

$$(3x^2 + 2y) dx + (2y + 2x) dy = 0$$

on the rectangle  $\{-2 \leq x \leq 2, -2 \leq y \leq 2\}$ . (See Exercise 37(b)).

27. **L**

(a) Solve the exact equation

$$(x^3y^4 + 2x) dx + (x^4y^3 + 3y) dy = 0 \tag{A}$$

implicitly.

(b) For what choices of  $(x_0, y_0)$  does Theorem 2.3.1 imply that the initial value problem

$$(x^3y^4 + 2x) dx + (x^4y^3 + 3y) dy = 0, \quad y(x_0) = y_0, \tag{B}$$

has a unique solution on an open interval  $(a, b)$  that contains  $x_0$ ?

- (c) Plot a direction field and some integral curves for (A) on a rectangular region centered at the origin. What is the interval of validity of the solution of (B)?

28. L

- (a) Solve the exact equation

$$(x^2 + y^2) dx + 2xy dy = 0 \quad (\text{A})$$

implicitly.

- (b) For what choices of  $(x_0, y_0)$  does Theorem 2.3.1 imply that the initial value problem

$$(x^2 + y^2) dx + 2xy dy = 0, \quad y(x_0) = y_0, \quad (\text{B})$$

has a unique solution  $y = y(x)$  on some open interval  $(a, b)$  that contains  $x_0$ ?

- (c) Plot a direction field and some integral curves for (A). From the plot determine, the interval  $(a, b)$  of (b), the monotonicity properties (if any) of the solution of (B), and  $\lim_{x \rightarrow a^+} y(x)$  and  $\lim_{x \rightarrow b^-} y(x)$ . HINT: *Your answers will depend upon which quadrant contains  $(x_0, y_0)$ .*

29. Find all functions  $M$  such that the equation is exact.

- (a)  $M(x, y) dx + (x^2 - y^2) dy = 0$   
 (b)  $M(x, y) dx + 2xy \sin x \cos y dy = 0$   
 (c)  $M(x, y) dx + (e^x - e^y \sin x) dy = 0$

30. Find all functions  $N$  such that the equation is exact.

- (a)  $(x^3 y^2 + 2xy + 3y^2) dx + N(x, y) dy = 0$   
 (b)  $(\ln xy + 2y \sin x) dx + N(x, y) dy = 0$   
 (c)  $(x \sin x + y \sin y) dx + N(x, y) dy = 0$

31. Suppose  $M, N$ , and their partial derivatives are continuous on an open rectangle  $R$ , and  $G$  is an antiderivative of  $M$  with respect to  $x$ ; that is,

$$\frac{\partial G}{\partial x} = M.$$

Show that if  $M_y \neq N_x$  in  $R$  then the function

$$N - \frac{\partial G}{\partial y}$$

is not independent of  $x$ .

32. Prove: If the equations  $M_1 dx + N_1 dy = 0$  and  $M_2 dx + N_2 dy = 0$  are exact on an open rectangle  $R$ , so is the equation

$$(M_1 + M_2) dx + (N_1 + N_2) dy = 0.$$

33. Find conditions on the constants  $A, B, C$ , and  $D$  such that the equation

$$(Ax + By) dx + (Cx + Dy) dy = 0$$

is exact.

34. Find conditions on the constants  $A, B, C, D, E$ , and  $F$  such that the equation

$$(Ax^2 + Bxy + Cy^2) dx + (Dx^2 + Exy + Fy^2) dy = 0$$

is exact.

35. Suppose  $M$  and  $N$  are continuous and have continuous partial derivatives  $M_y$  and  $N_x$  that satisfy the exactness condition  $M_y = N_x$  on an open rectangle  $R$ . Show that if  $(x, y)$  is in  $R$  and

$$F(x, y) = \int_{x_0}^x M(s, y_0) ds + \int_{y_0}^y N(x, t) dt,$$

then  $F_x = M$  and  $F_y = N$ .

36. Under the assumptions of Exercise 35, show that

$$F(x, y) = \int_{y_0}^y N(x_0, s) ds + \int_{x_0}^x M(t, y) dt.$$

37. Use the method suggested by Exercise 35, with  $(x_0, y_0) = (0, 0)$ , to solve these exact equations:

(a)  $(x^3y^4 + x) dx + (x^4y^3 + y) dy = 0$

(b)  $(x^2 + y^2) dx + 2xy dy = 0$

(c)  $(3x^2 + 2y) dx + (2y + 2x) dy = 0$

38. Solve the initial value problem

$$y' + \frac{2}{x}y = -\frac{2xy}{x^2 + 2x^2y + 1}, \quad y(1) = -2.$$

39. Solve the initial value problem

$$y' - \frac{3}{x}y = \frac{2x^4(4x^3 - 3y)}{3x^5 + 3x^3 + 2y}, \quad y(1) = 1.$$

40. Solve the initial value problem

$$y' + 2xy = -e^{-x^2} \left( \frac{3x + 2ye^{x^2}}{2x + 3ye^{x^2}} \right), \quad y(0) = -1.$$

41. Rewrite the separable equation

$$h(y)y' = g(x) \tag{A}$$

as an exact equation

$$M(x, y) dx + N(x, y) dy = 0. \tag{B}$$

Show that applying the method of this section to (B) yields the same solutions that would be obtained by applying the method of separation of variables to (A)

42. Suppose all second partial derivatives of  $M = M(x, y)$  and  $N = N(x, y)$  are continuous and  $M dx + N dy = 0$  and  $-N dx + M dy = 0$  are exact on an open rectangle  $R$ . Show that  $M_{xx} + M_{yy} = N_{xx} + N_{yy} = 0$  on  $R$ .
43. Suppose all second partial derivatives of  $F = F(x, y)$  are continuous and  $F_{xx} + F_{yy} = 0$  on an open rectangle  $R$ . (A function with these properties is said to be *harmonic*; see also Exercise 42.) Show that  $-F_y dx + F_x dy = 0$  is exact on  $R$ , and therefore there's a function  $G$  such that  $G_x = -F_y$  and  $G_y = F_x$  in  $R$ . (A function  $G$  with this property is said to be a *harmonic conjugate* of  $F$ .)



44. Verify that the following functions are harmonic, and find all their harmonic conjugates. (See Exercise 43.)

(a)  $x^2 - y^2$

(b)  $e^x \cos y$

(c)  $x^3 - 3xy^2$

(d)  $\cos x \cosh y$

(e)  $\sin x \cosh y$

## 2.6 INTEGRATING FACTORS

In Section 2.5 we saw that if  $M$ ,  $N$ ,  $M_y$  and  $N_x$  are continuous and  $M_y = N_x$  on an open rectangle  $R$  then

$$M(x, y) dx + N(x, y) dy = 0 \quad (2.6.1)$$

is exact on  $R$ . Sometimes an equation that isn't exact can be made exact by multiplying it by an appropriate function. For example,

$$(3x + 2y^2) dx + 2xy dy = 0 \quad (2.6.2)$$

is not exact, since  $M_y(x, y) = 4y \neq N_x(x, y) = 2y$  in (2.6.2). However, multiplying (2.6.2) by  $x$  yields

$$(3x^2 + 2xy^2) dx + 2x^2y dy = 0, \quad (2.6.3)$$

which is exact, since  $M_y(x, y) = N_x(x, y) = 4xy$  in (2.6.3). Solving (2.6.3) by the procedure given in Section 2.5 yields the implicit solution

$$x^3 + x^2y^2 = c.$$

A function  $\mu = \mu(x, y)$  is an *integrating factor* for (2.6.1) if

$$\mu(x, y)M(x, y) dx + \mu(x, y)N(x, y) dy = 0 \quad (2.6.4)$$

is exact. If we know an integrating factor  $\mu$  for (2.6.1), we can solve the exact equation (2.6.4) by the method of Section 2.5. It would be nice if we could say that (2.6.1) and (2.6.4) always have the same solutions, but this isn't so. For example, a solution  $y = y(x)$  of (2.6.4) such that  $\mu(x, y(x)) = 0$  on some interval  $a < x < b$  could fail to be a solution of (2.6.1) (Exercise 1), while (2.6.1) may have a solution  $y = y(x)$  such that  $\mu(x, y(x))$  isn't even defined (Exercise 2). Similar comments apply if  $y$  is the independent variable and  $x$  is the dependent variable in (2.6.1) and (2.6.4). However, if  $\mu(x, y)$  is defined and nonzero for all  $(x, y)$ , (2.6.1) and (2.6.4) are equivalent; that is, they have the same solutions.

### Finding Integrating Factors

By applying Theorem 2.5.2 (with  $M$  and  $N$  replaced by  $\mu M$  and  $\mu N$ ), we see that (2.6.4) is exact on an open rectangle  $R$  if  $\mu M$ ,  $\mu N$ ,  $(\mu M)_y$ , and  $(\mu N)_x$  are continuous and

$$\frac{\partial}{\partial y}(\mu M) = \frac{\partial}{\partial x}(\mu N) \quad \text{or, equivalently,} \quad \mu_y M + \mu M_y = \mu_x N + \mu N_x$$

on  $R$ . It's better to rewrite the last equation as

$$\mu(M_y - N_x) = \mu_x N - \mu_y M, \quad (2.6.5)$$

which reduces to the known result for exact equations; that is, if  $M_y = N_x$  then (2.6.5) holds with  $\mu = 1$ , so (2.6.1) is exact.

You may think (2.6.5) is of little value, since it involves *partial* derivatives of the unknown integrating factor  $\mu$ , and we haven't studied methods for solving such equations. However, we'll now show that (2.6.5) is useful if we restrict our search to integrating factors that are products of a function of  $x$  and a

function of  $y$ ; that is,  $\mu(x, y) = P(x)Q(y)$ . We're not saying that *every* equation  $M dx + N dy = 0$  has an integrating factor of this form; rather, we're saying that *some* equations have such integrating factors. We'll now develop a way to determine whether a given equation has such an integrating factor, and a method for finding the integrating factor in this case.

If  $\mu(x, y) = P(x)Q(y)$ , then  $\mu_x(x, y) = P'(x)Q(y)$  and  $\mu_y(x, y) = P(x)Q'(y)$ , so (2.6.5) becomes

$$P(x)Q(y)(M_y - N_x) = P'(x)Q(y)N - P(x)Q'(y)M, \quad (2.6.6)$$

or, after dividing through by  $P(x)Q(y)$ ,

$$M_y - N_x = \frac{P'(x)}{P(x)}N - \frac{Q'(y)}{Q(y)}M. \quad (2.6.7)$$

Now let

$$p(x) = \frac{P'(x)}{P(x)} \quad \text{and} \quad q(y) = \frac{Q'(y)}{Q(y)},$$

so (2.6.7) becomes

$$M_y - N_x = p(x)N - q(y)M. \quad (2.6.8)$$

We obtained (2.6.8) by *assuming* that  $M dx + N dy = 0$  has an integrating factor  $\mu(x, y) = P(x)Q(y)$ . However, we can now view (2.6.7) differently: If there are functions  $p = p(x)$  and  $q = q(y)$  that satisfy (2.6.8) and we define

$$P(x) = \pm e^{\int p(x) dx} \quad \text{and} \quad Q(y) = \pm e^{\int q(y) dy}, \quad (2.6.9)$$

then reversing the steps that led from (2.6.6) to (2.6.8) shows that  $\mu(x, y) = P(x)Q(y)$  is an integrating factor for  $M dx + N dy = 0$ . In using this result, we take the constants of integration in (2.6.9) to be zero and choose the signs conveniently so the integrating factor has the simplest form.

There's no simple general method for ascertaining whether functions  $p = p(x)$  and  $q = q(y)$  satisfying (2.6.8) exist. However, the next theorem gives simple sufficient conditions for the given equation to have an integrating factor that depends on only one of the independent variables  $x$  and  $y$ , and for finding an integrating factor in this case.

**Theorem 2.6.1** *Let  $M$ ,  $N$ ,  $M_y$ , and  $N_x$  be continuous on an open rectangle  $R$ . Then:*

(a) *If  $(M_y - N_x)/N$  is independent of  $y$  on  $R$  and we define*

$$p(x) = \frac{M_y - N_x}{N}$$

*then*

$$\mu(x) = \pm e^{\int p(x) dx} \quad (2.6.10)$$

*is an integrating factor for*

$$M(x, y) dx + N(x, y) dy = 0 \quad (2.6.11)$$

*on  $R$ .*

(b) *If  $(N_x - M_y)/M$  is independent of  $x$  on  $R$  and we define*

$$q(y) = \frac{N_x - M_y}{M},$$

*then*

$$\mu(y) = \pm e^{\int q(y) dy} \quad (2.6.12)$$

*is an integrating factor for (2.6.11) on  $R$ .*

**Proof** (a) If  $(M_y - N_x)/N$  is independent of  $y$ , then (2.6.8) holds with  $p = (M_y - N_x)/N$  and  $q \equiv 0$ . Therefore

$$P(x) = \pm e^{\int p(x) dx} \quad \text{and} \quad Q(y) = \pm e^{\int q(y) dy} = \pm e^0 = \pm 1,$$

so (2.6.10) is an integrating factor for (2.6.11) on  $R$ .

(b) If  $(N_x - M_y)/M$  is independent of  $x$  then eqrefeq:2.6.8 holds with  $p \equiv 0$  and  $q = (N_x - M_y)/M$ , and a similar argument shows that (2.6.12) is an integrating factor for (2.6.11) on  $R$ . ■

The next two examples show how to apply Theorem 2.6.1.

**Example 2.6.1** Find an integrating factor for the equation

$$(2xy^3 - 2x^3y^3 - 4xy^2 + 2x) dx + (3x^2y^2 + 4y) dy = 0 \quad (2.6.13)$$

and solve the equation.

**Solution** In (2.6.13)

$$M = 2xy^3 - 2x^3y^3 - 4xy^2 + 2x, \quad N = 3x^2y^2 + 4y,$$

and

$$M_y - N_x = (6xy^2 - 6x^3y^2 - 8xy) - 6xy^2 = -6x^3y^2 - 8xy,$$

so (2.6.13) isn't exact. However,

$$\frac{M_y - N_x}{N} = -\frac{6x^3y^2 + 8xy}{3x^2y^2 + 4y} = -2x$$

is independent of  $y$ , so Theorem 2.6.1(a) applies with  $p(x) = -2x$ . Since

$$\int p(x) dx = -\int 2x dx = -x^2,$$

$\mu(x) = e^{-x^2}$  is an integrating factor. Multiplying (2.6.13) by  $\mu$  yields the exact equation

$$e^{-x^2}(2xy^3 - 2x^3y^3 - 4xy^2 + 2x) dx + e^{-x^2}(3x^2y^2 + 4y) dy = 0. \quad (2.6.14)$$

To solve this equation, we must find a function  $F$  such that

$$F_x(x, y) = e^{-x^2}(2xy^3 - 2x^3y^3 - 4xy^2 + 2x) \quad (2.6.15)$$

and

$$F_y(x, y) = e^{-x^2}(3x^2y^2 + 4y). \quad (2.6.16)$$

Integrating (2.6.16) with respect to  $y$  yields

$$F(x, y) = e^{-x^2}(x^2y^3 + 2y^2) + \psi(x). \quad (2.6.17)$$

Differentiating this with respect to  $x$  yields

$$F_x(x, y) = e^{-x^2}(2xy^3 - 2x^3y^3 - 4xy^2) + \psi'(x).$$

Comparing this with (2.6.15) shows that  $\psi'(x) = 2xe^{-x^2}$ ; therefore, we can let  $\psi(x) = -e^{-x^2}$  in (2.6.17) and conclude that

$$e^{-x^2}(y^2(x^2y + 2) - 1) = c$$

is an implicit solution of (2.6.14). It is also an implicit solution of (2.6.13).

Figure 2.6.1 shows a direction field and some integral curves for (2.6.13)

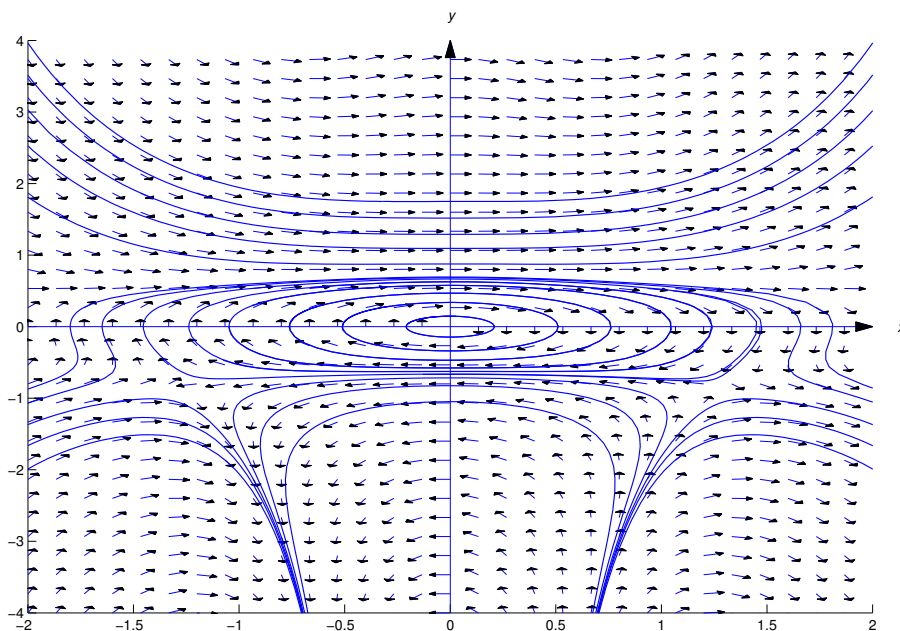

Figure 2.6.1 A direction field and integral curves for  $(2xy^3 - 2x^3y^3 - 4xy^2 + 2x) dx + (3x^2y^2 + 4y) dy = 0$

**Example 2.6.2** Find an integrating factor for

$$2xy^3 dx + (3x^2y^2 + x^2y^3 + 1) dy = 0 \quad (2.6.18)$$

and solve the equation.

**Solution** In (2.6.18),

$$M = 2xy^3, \quad N = 3x^2y^2 + x^2y^3 + 1,$$

and

$$M_y - N_x = 6xy^2 - (6xy^2 + 2xy^3) = -2xy^3,$$

so (2.6.18) isn't exact. Moreover,

$$\frac{M_y - N_x}{N} = -\frac{2xy^3}{3x^2y^2 + x^2y^3 + 1}$$

is not independent of  $y$ , so Theorem 2.6.1(a) does not apply. However, Theorem 2.6.1(b) does apply, since

$$\frac{N_x - M_y}{M} = \frac{2xy^3}{2xy^3} = 1$$

is independent of  $x$ , so we can take  $q(y) = 1$ . Since

$$\int q(y) dy = \int dy = y,$$

$\mu(y) = e^y$  is an integrating factor. Multiplying (2.6.18) by  $\mu$  yields the exact equation

$$2xy^3 e^y dx + (3x^2 y^2 + x^2 y^3 + 1)e^y dy = 0. \quad (2.6.19)$$

To solve this equation, we must find a function  $F$  such that

$$F_x(x, y) = 2xy^3 e^y \quad (2.6.20)$$

and

$$F_y(x, y) = (3x^2 y^2 + x^2 y^3 + 1)e^y. \quad (2.6.21)$$

Integrating (2.6.20) with respect to  $x$  yields

$$F(x, y) = x^2 y^3 e^y + \phi(y). \quad (2.6.22)$$

Differentiating this with respect to  $y$  yields

$$F_y = (3x^2 y^2 + x^2 y^3)e^y + \phi'(y),$$

and comparing this with (2.6.21) shows that  $\phi'(y) = e^y$ . Therefore we set  $\phi(y) = e^y$  in (2.6.22) and conclude that

$$(x^2 y^3 + 1)e^y = c$$

is an implicit solution of (2.6.19). It is also an implicit solution of (2.6.18). Figure 2.6.2 shows a direction field and some integral curves for (2.6.18). ■

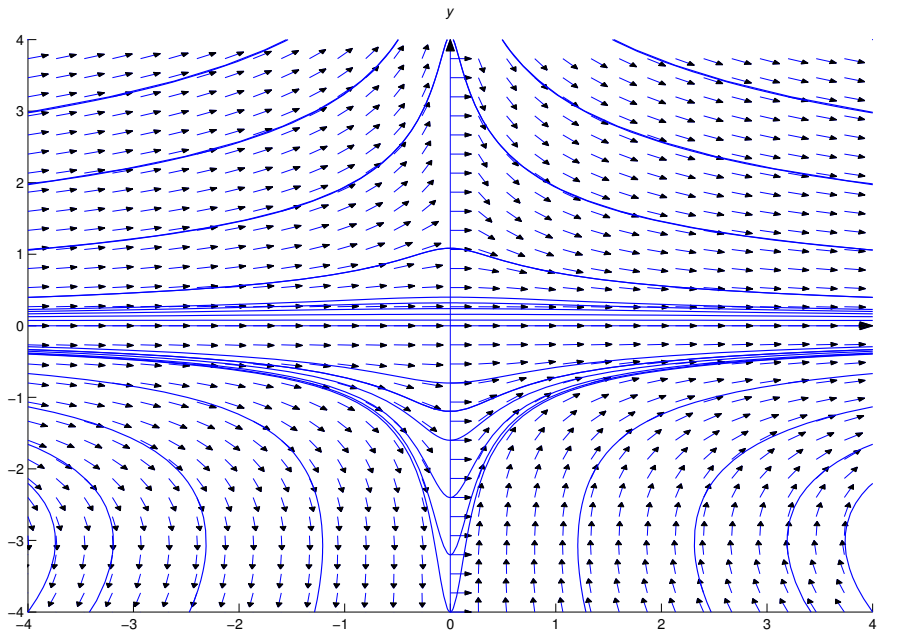

Figure 2.6.2 A direction field and integral curves for  $2xy^3 e^y dx + (3x^2 y^2 + x^2 y^3 + 1)e^y dy = 0$

Theorem 2.6.1 does not apply in the next example, but the more general argument that led to Theorem 2.6.1 provides an integrating factor.

**Example 2.6.3** Find an integrating factor for

$$(3xy + 6y^2) dx + (2x^2 + 9xy) dy = 0 \quad (2.6.23)$$

and solve the equation.

**Solution** In (2.6.23)

$$M = 3xy + 6y^2, \quad N = 2x^2 + 9xy,$$

and

$$M_y - N_x = (3x + 12y) - (4x + 9y) = -x + 3y.$$

Therefore

$$\frac{M_y - N_x}{M} = \frac{-x + 3y}{3xy + 6y^2} \quad \text{and} \quad \frac{N_x - M_y}{N} = \frac{x - 3y}{2x^2 + 9xy},$$

so Theorem 2.6.1 does not apply. Following the more general argument that led to Theorem 2.6.1, we look for functions  $p = p(x)$  and  $q = q(y)$  such that

$$M_y - N_x = p(x)N - q(y)M;$$

that is,

$$-x + 3y = p(x)(2x^2 + 9xy) - q(y)(3xy + 6y^2).$$

Since the left side contains only first degree terms in  $x$  and  $y$ , we rewrite this equation as

$$xp(x)(2x + 9y) - yq(y)(3x + 6y) = -x + 3y.$$

This will be an identity if

$$xp(x) = A \quad \text{and} \quad yq(y) = B, \quad (2.6.24)$$

where  $A$  and  $B$  are constants such that

$$-x + 3y = A(2x + 9y) - B(3x + 6y),$$

or, equivalently,

$$-x + 3y = (2A - 3B)x + (9A - 6B)y.$$

Equating the coefficients of  $x$  and  $y$  on both sides shows that the last equation holds for all  $(x, y)$  if

$$\begin{aligned} 2A - 3B &= -1 \\ 9A - 6B &= 3, \end{aligned}$$

which has the solution  $A = 1, B = 1$ . Therefore (2.6.24) implies that

$$p(x) = \frac{1}{x} \quad \text{and} \quad q(y) = \frac{1}{y}.$$

Since

$$\int p(x) dx = \ln|x| \quad \text{and} \quad \int q(y) dy = \ln|y|,$$

we can let  $P(x) = x$  and  $Q(y) = y$ ; hence,  $\mu(x, y) = xy$  is an integrating factor. Multiplying (2.6.23) by  $\mu$  yields the exact equation

$$(3x^2y^2 + 6xy^3) dx + (2x^3y + 9x^2y^2) dy = 0.$$

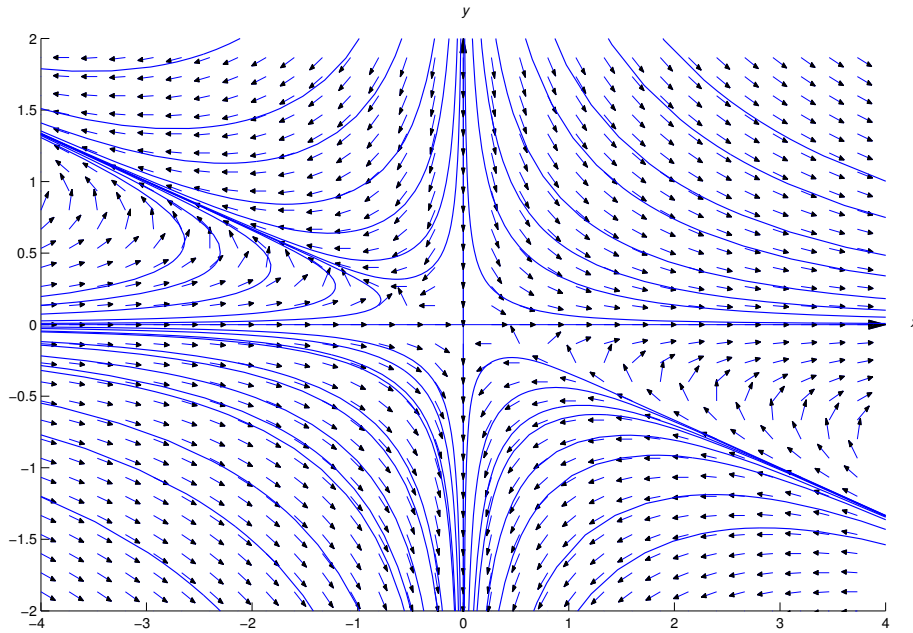

Figure 2.6.3 A direction field and integral curves for  $(3xy + 6y^2) dx + (2x^2 + 9xy) dy = 0$

We leave it to you to use the method of Section 2.5 to show that this equation has the implicit solution

$$x^3y^2 + 3x^2y^3 = c. \quad (2.6.25)$$

This is also an implicit solution of (2.6.23). Since  $x \equiv 0$  and  $y \equiv 0$  satisfy (2.6.25), you should check to see that  $x \equiv 0$  and  $y \equiv 0$  are also solutions of (2.6.23). (Why is it necessary to check this?)

Figure 2.6.3 shows a direction field and integral curves for (2.6.23).

See Exercise 28 for a general discussion of equations like (2.6.23).

**Example 2.6.4** The separable equation

$$-y dx + (x + x^6) dy = 0 \quad (2.6.26)$$

can be converted to the exact equation

$$-\frac{dx}{x + x^6} + \frac{dy}{y} = 0 \quad (2.6.27)$$

by multiplying through by the integrating factor

$$\mu(x, y) = \frac{1}{y(x + x^6)}.$$

However, to solve (2.6.27) by the method of Section 2.5 we would have to evaluate the nasty integral

$$\int \frac{dx}{x + x^6}.$$

Instead, we solve (2.6.26) explicitly for  $y$  by finding an integrating factor of the form  $\mu(x, y) = x^a y^b$ .

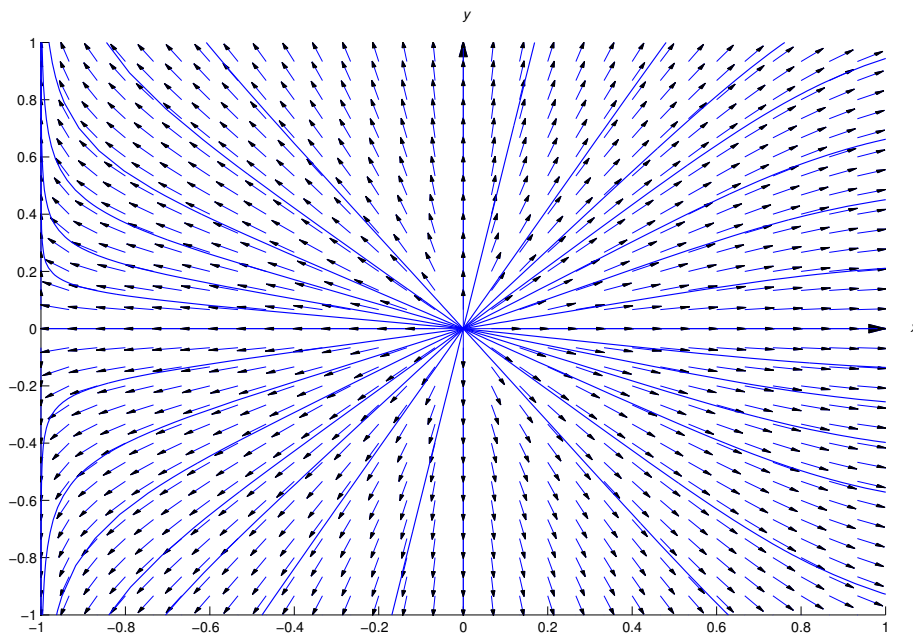

Figure 2.6.4 A direction field and integral curves for  $-y dx + (x + x^6) dy = 0$

**Solution** In (2.6.26)

$$M = -y, \quad N = x + x^6,$$

and

$$M_y - N_x = -1 - (1 + 6x^5) = -2 - 6x^5.$$

We look for functions  $p = p(x)$  and  $q = q(y)$  such that

$$M_y - N_x = p(x)N - q(y)M;$$

that is,

$$-2 - 6x^5 = p(x)(x + x^6) + q(y)y. \quad (2.6.28)$$

The right side will contain the term  $-6x^5$  if  $p(x) = -6/x$ . Then (2.6.28) becomes

$$-2 - 6x^5 = -6 - 6x^5 + q(y)y,$$

so  $q(y) = 4/y$ . Since

$$\int p(x) dx = - \int \frac{6}{x} dx = -6 \ln |x| = \ln \frac{1}{x^6},$$

and

$$\int q(y) dy = \int \frac{4}{y} dy = 4 \ln |y| = \ln y^4,$$

we can take  $P(x) = x^{-6}$  and  $Q(y) = y^4$ , which yields the integrating factor  $\mu(x, y) = x^{-6}y^4$ . Multiplying (2.6.26) by  $\mu$  yields the exact equation

$$-\frac{y^5}{x^6} dx + \left( \frac{y^4}{x^5} + y^4 \right) dy = 0.$$



We leave it to you to use the method of the Section 2.5 to show that this equation has the implicit solution

$$\left(\frac{y}{x}\right)^5 + y^5 = k.$$

Solving for  $y$  yields

$$y = k^{1/5}x(1 + x^5)^{-1/5},$$

which we rewrite as

$$y = cx(1 + x^5)^{-1/5}$$

by renaming the arbitrary constant. This is also a solution of (2.6.26).

Figure 2.6.4 shows a direction field and some integral curves for (2.6.26).

## 2.6 Exercises

---

1. (a) Verify that  $\mu(x, y) = y$  is an integrating factor for

$$y \, dx + \left(2x + \frac{1}{y}\right) \, dy = 0 \tag{A}$$

on any open rectangle that does not intersect the  $x$  axis or, equivalently, that

$$y^2 \, dx + (2xy + 1) \, dy = 0 \tag{B}$$

is exact on any such rectangle.

- (b) Verify that  $y \equiv 0$  is a solution of (B), but not of (A).

- (c) Show that

$$y(xy + 1) = c \tag{C}$$

is an implicit solution of (B), and explain why every differentiable function  $y = y(x)$  other than  $y \equiv 0$  that satisfies (C) is also a solution of (A).

2. (a) Verify that  $\mu(x, y) = 1/(x - y)^2$  is an integrating factor for

$$-y^2 \, dx + x^2 \, dy = 0 \tag{A}$$

on any open rectangle that does not intersect the line  $y = x$  or, equivalently, that

$$-\frac{y^2}{(x - y)^2} \, dx + \frac{x^2}{(x - y)^2} \, dy = 0 \tag{B}$$

is exact on any such rectangle.

- (b) Use Theorem 2.2.1 to show that

$$\frac{xy}{(x - y)} = c \tag{C}$$

is an implicit solution of (B), and explain why it's also an implicit solution of (A)

- (c) Verify that  $y = x$  is a solution of (A), even though it can't be obtained from (C).

*In Exercises 3–16 find an integrating factor; that is a function of only one variable, and solve the given equation.*

3.  $y \, dx - x \, dy = 0$

4.  $3x^2y \, dx + 2x^3 \, dy = 0$

5.  $2y^3 \, dx + 3y^2 \, dy = 0$

6.  $(5xy + 2y + 5) \, dx + 2x \, dy = 0$

7.  $(xy + x + 2y + 1) dx + (x + 1) dy = 0$
8.  $(27xy^2 + 8y^3) dx + (18x^2y + 12xy^2) dy = 0$
9.  $(6xy^2 + 2y) dx + (12x^2y + 6x + 3) dy = 0$
10.  $y^2 dx + \left(xy^2 + 3xy + \frac{1}{y}\right) dy = 0$
11.  $(12x^3y + 24x^2y^2) dx + (9x^4 + 32x^3y + 4y) dy = 0$
12.  $(x^2y + 4xy + 2y) dx + (x^2 + x) dy = 0$
13.  $-y dx + (x^4 - x) dy = 0$
14.  $\cos x \cos y dx + (\sin x \cos y - \sin x \sin y + y) dy = 0$
15.  $(2xy + y^2) dx + (2xy + x^2 - 2x^2y^2 - 2xy^3) dy = 0$
16.  $y \sin y dx + x(\sin y - y \cos y) dy = 0$

In Exercises 17–23 find an integrating factor of the form  $\mu(x, y) = P(x)Q(y)$  and solve the given equation.

17.  $y(1 + 5 \ln |x|) dx + 4x \ln |x| dy = 0$
18.  $(\alpha y + \gamma xy) dx + (\beta x + \delta xy) dy = 0$
19.  $(3x^2y^3 - y^2 + y) dx + (-xy + 2x) dy = 0$
20.  $2y dx + 3(x^2 + x^2y^3) dy = 0$
21.  $(a \cos xy - y \sin xy) dx + (b \cos xy - x \sin xy) dy = 0$
22.  $x^4y^4 dx + x^5y^3 dy = 0$
23.  $y(x \cos x + 2 \sin x) dx + x(y + 1) \sin x dy = 0$

In Exercises 24–27 find an integrating factor and solve the equation. Plot a direction field and some integral curves for the equation in the indicated rectangular region.

24. C/G  $(x^4y^3 + y) dx + (x^5y^2 - x) dy = 0; \quad \{-1 \leq x \leq 1, -1 \leq y \leq 1\}$
25. C/G  $(3xy + 2y^2 + y) dx + (x^2 + 2xy + x + 2y) dy = 0; \quad \{-2 \leq x \leq 2, -2 \leq y \leq 2\}$
26. C/G  $(12xy + 6y^3) dx + (9x^2 + 10xy^2) dy = 0; \quad \{-2 \leq x \leq 2, -2 \leq y \leq 2\}$
27. C/G  $(3x^2y^2 + 2y) dx + 2x dy = 0; \quad \{-4 \leq x \leq 4, -4 \leq y \leq 4\}$
28. Suppose  $a, b, c,$  and  $d$  are constants such that  $ad - bc \neq 0$ , and let  $m$  and  $n$  be arbitrary real numbers. Show that

$$(ax^m y + by^{n+1}) dx + (cx^{m+1} + dxy^n) dy = 0$$

has an integrating factor  $\mu(x, y) = x^\alpha y^\beta$ .

29. Suppose  $M, N, M_x,$  and  $N_y$  are continuous for all  $(x, y)$ , and  $\mu = \mu(x, y)$  is an integrating factor for

$$M(x, y) dx + N(x, y) dy = 0. \quad (\text{A})$$

Assume that  $\mu_x$  and  $\mu_y$  are continuous for all  $(x, y)$ , and suppose  $y = y(x)$  is a differentiable function such that  $\mu(x, y(x)) = 0$  and  $\mu_x(x, y(x)) \neq 0$  for all  $x$  in some interval  $I$ . Show that  $y$  is a solution of (A) on  $I$ .

30. According to Theorem 2.1.2, the general solution of the linear nonhomogeneous equation

$$y' + p(x)y = f(x) \quad (\text{A})$$

is

$$y = y_1(x) \left( c + \int f(x)/y_1(x) dx \right), \quad (\text{B})$$

where  $y_1$  is any nontrivial solution of the complementary equation  $y' + p(x)y = 0$ . In this exercise we obtain this conclusion in a different way. You may find it instructive to apply the method suggested here to solve some of the exercises in Section 2.1.

(a) Rewrite (A) as

$$[p(x)y - f(x)] dx + dy = 0, \quad (\text{C})$$

and show that  $\mu = \pm e^{\int p(x) dx}$  is an integrating factor for (C).

(b) Multiply (A) through by  $\mu = \pm e^{\int p(x) dx}$  and verify that the resulting equation can be rewritten as

$$(\mu(x)y)' = \mu(x)f(x).$$

Then integrate both sides of this equation and solve for  $y$  to show that the general solution of (A) is

$$y = \frac{1}{\mu(x)} \left( c + \int f(x)\mu(x) dx \right).$$

Why is this form of the general solution equivalent to (B)?



# CHAPTER 3

## Numerical Methods

In this chapter we study numerical methods for solving a first order differential equation

$$y' = f(x, y).$$

SECTION 3.1 deals with *Euler's method*, which is really too crude to be of much use in practical applications. However, its simplicity allows for an introduction to the ideas required to understand the better methods discussed in the other two sections.

SECTION 3.2 discusses improvements on Euler's method.

SECTION 3.3 deals with the *Runge-Kutta* method, perhaps the most widely used method for numerical solution of differential equations.

### 3.1 EULER'S METHOD

If an initial value problem

$$y' = f(x, y), \quad y(x_0) = y_0 \quad (3.1.1)$$

can't be solved analytically, it's necessary to resort to numerical methods to obtain useful approximations to a solution of (3.1.1). We'll consider such methods in this chapter.

We're interested in computing approximate values of the solution of (3.1.1) at equally spaced points  $x_0, x_1, \dots, x_n = b$  in an interval  $[x_0, b]$ . Thus,

$$x_i = x_0 + ih, \quad i = 0, 1, \dots, n,$$

where

$$h = \frac{b - x_0}{n}.$$

We'll denote the approximate values of the solution at these points by  $y_0, y_1, \dots, y_n$ ; thus,  $y_i$  is an approximation to  $y(x_i)$ . We'll call

$$e_i = y(x_i) - y_i$$

the *error at the  $i$ th step*. Because of the initial condition  $y(x_0) = y_0$ , we'll always have  $e_0 = 0$ . However, in general  $e_i \neq 0$  if  $i > 0$ .

We encounter two sources of error in applying a numerical method to solve an initial value problem:

- The formulas defining the method are based on some sort of approximation. Errors due to the inaccuracy of the approximation are called *truncation errors*.
- Computers do arithmetic with a fixed number of digits, and therefore make errors in evaluating the formulas defining the numerical methods. Errors due to the computer's inability to do exact arithmetic are called *roundoff errors*.

Since a careful analysis of roundoff error is beyond the scope of this book, we'll consider only truncation errors.

#### Euler's Method

The simplest numerical method for solving (3.1.1) is *Euler's method*. This method is so crude that it is seldom used in practice; however, its simplicity makes it useful for illustrative purposes.

Euler's method is based on the assumption that the tangent line to the integral curve of (3.1.1) at  $(x_i, y(x_i))$  approximates the integral curve over the interval  $[x_i, x_{i+1}]$ . Since the slope of the integral curve of (3.1.1) at  $(x_i, y(x_i))$  is  $y'(x_i) = f(x_i, y(x_i))$ , the equation of the tangent line to the integral curve at  $(x_i, y(x_i))$  is

$$y = y(x_i) + f(x_i, y(x_i))(x - x_i). \quad (3.1.2)$$

Setting  $x = x_{i+1} = x_i + h$  in (3.1.2) yields

$$y_{i+1} = y(x_i) + hf(x_i, y(x_i)) \quad (3.1.3)$$

as an approximation to  $y(x_{i+1})$ . Since  $y(x_0) = y_0$  is known, we can use (3.1.3) with  $i = 0$  to compute

$$y_1 = y_0 + hf(x_0, y_0).$$

However, setting  $i = 1$  in (3.1.3) yields

$$y_2 = y(x_1) + hf(x_1, y(x_1)),$$

which isn't useful, since we *don't know*  $y(x_1)$ . Therefore we replace  $y(x_1)$  by its approximate value  $y_1$  and redefine

$$y_2 = y_1 + hf(x_1, y_1).$$

Having computed  $y_2$ , we can compute

$$y_3 = y_2 + hf(x_2, y_2).$$

In general, Euler's method starts with the known value  $y(x_0) = y_0$  and computes  $y_1, y_2, \dots, y_n$  successively by with the formula

$$y_{i+1} = y_i + hf(x_i, y_i), \quad 0 \leq i \leq n-1. \quad (3.1.4)$$

The next example illustrates the computational procedure indicated in Euler's method.

**Example 3.1.1** Use Euler's method with  $h = 0.1$  to find approximate values for the solution of the initial value problem

$$y' + 2y = x^3 e^{-2x}, \quad y(0) = 1 \quad (3.1.5)$$

at  $x = 0.1, 0.2, 0.3$ .

**Solution** We rewrite (3.1.5) as

$$y' = -2y + x^3 e^{-2x}, \quad y(0) = 1,$$

which is of the form (3.1.1), with

$$f(x, y) = -2y + x^3 e^{-2x}, \quad x_0 = 0, \text{ and } y_0 = 1.$$

Euler's method yields

$$\begin{aligned} y_1 &= y_0 + hf(x_0, y_0) \\ &= 1 + (.1)f(0, 1) = 1 + (.1)(-2) = .8, \\ y_2 &= y_1 + hf(x_1, y_1) \\ &= .8 + (.1)f(.1, .8) = .8 + (.1)(-2(.8) + (.1)^3 e^{-.2}) = .640081873, \\ y_3 &= y_2 + hf(x_2, y_2) \\ &= .640081873 + (.1)(-2(.640081873) + (.2)^3 e^{-.4}) = .512601754. \blacksquare \end{aligned}$$

We've written the details of these computations to ensure that you understand the procedure. However, in the rest of the examples as well as the exercises in this chapter, we'll assume that you can use a programmable calculator or a computer to carry out the necessary computations.

### Examples Illustrating The Error in Euler's Method

**Example 3.1.2** Use Euler's method with step sizes  $h = 0.1$ ,  $h = 0.05$ , and  $h = 0.025$  to find approximate values of the solution of the initial value problem

$$y' + 2y = x^3 e^{-2x}, \quad y(0) = 1$$

at  $x = 0, 0.1, 0.2, 0.3, \dots, 1.0$ . Compare these approximate values with the values of the exact solution

$$y = \frac{e^{-2x}}{4}(x^4 + 4), \quad (3.1.6)$$

which can be obtained by the method of Section 2.1. (Verify.)

**Solution** Table 3.1.1 shows the values of the exact solution (3.1.6) at the specified points, and the approximate values of the solution at these points obtained by Euler's method with step sizes  $h = 0.1$ ,  $h = 0.05$ , and  $h = 0.025$ . In examining this table, keep in mind that the approximate values in the column corresponding to  $h = .05$  are actually the results of 20 steps with Euler's method. We haven't listed the estimates of the solution obtained for  $x = 0.05, 0.15, \dots$ , since there's nothing to compare them with in the column corresponding to  $h = 0.1$ . Similarly, the approximate values in the column corresponding to  $h = 0.025$  are actually the results of 40 steps with Euler's method.

Table 3.1.1. Numerical solution of  $y' + 2y = x^3e^{-2x}$ ,  $y(0) = 1$ , by Euler's method.

$x$	$h = 0.1$	$h = 0.05$	$h = 0.025$	Exact
0.0	1.000000000	1.000000000	1.000000000	1.000000000
0.1	0.800000000	0.810005655	0.814518349	0.818751221
0.2	0.640081873	0.656266437	0.663635953	0.670588174
0.3	0.512601754	0.532290981	0.541339495	0.549922980
0.4	0.411563195	0.432887056	0.442774766	0.452204669
0.5	0.332126261	0.353785015	0.363915597	0.373627557
0.6	0.270299502	0.291404256	0.301359885	0.310952904
0.7	0.222745397	0.242707257	0.252202935	0.261398947
0.8	0.186654593	0.205105754	0.213956311	0.222570721
0.9	0.159660776	0.176396883	0.184492463	0.192412038
1.0	0.139778910	0.154715925	0.162003293	0.169169104

You can see from Table 3.1.1 that decreasing the step size improves the accuracy of Euler's method. For example,

$$y_{\text{exact}}(1) - y_{\text{approx}}(1) \approx \begin{cases} .0293 & \text{with } h = 0.1, \\ .0144 & \text{with } h = 0.05, \\ .0071 & \text{with } h = 0.025. \end{cases}$$

Based on this scanty evidence, you might guess that the error in approximating the exact solution at a *fixed value of  $x$*  by Euler's method is roughly halved when the step size is halved. You can find more evidence to support this conjecture by examining Table 3.1.2, which lists the approximate values of  $y_{\text{exact}} - y_{\text{approx}}$  at  $x = 0.1, 0.2, \dots, 1.0$ .

Table 3.1.2. Errors in approximate solutions of  $y' + 2y = x^3e^{-2x}$ ,  $y(0) = 1$ , obtained by Euler's method.

$x$	$h = 0.1$	$h = 0.05$	$h = 0.025$
0.1	0.0187	0.0087	0.0042
0.2	0.0305	0.0143	0.0069
0.3	0.0373	0.0176	0.0085
0.4	0.0406	0.0193	0.0094
0.5	0.0415	0.0198	0.0097
0.6	0.0406	0.0195	0.0095
0.7	0.0386	0.0186	0.0091
0.8	0.0359	0.0174	0.0086
0.9	0.0327	0.0160	0.0079
1.0	0.0293	0.0144	0.0071

**Example 3.1.3** Tables 3.1.3 and 3.1.4 show analogous results for the nonlinear initial value problem

$$y' = -2y^2 + xy + x^2, \quad y(0) = 1, \quad (3.1.7)$$



except in this case we can't solve (3.1.7) exactly. The results in the "Exact" column were obtained by using a more accurate numerical method known as the *Runge-Kutta* method with a small step size. They are exact to eight decimal places. ■

Since we think it's important in evaluating the accuracy of the numerical methods that we'll be studying in this chapter, we often include a column listing values of the exact solution of the initial value problem, even if the directions in the example or exercise don't specifically call for it. If quotation marks are included in the heading, the values were obtained by applying the Runge-Kutta method in a way that's explained in Section 3.3. If quotation marks are not included, the values were obtained from a known formula for the solution. In either case, the values are exact to eight places to the right of the decimal point.

Table 3.1.3. Numerical solution of  $y' = -2y^2 + xy + x^2$ ,  $y(0) = 1$ , by Euler's method.

$x$	$h = 0.1$	$h = 0.05$	$h = 0.025$	"Exact"
0.0	1.000000000	1.000000000	1.000000000	1.000000000
0.1	0.800000000	0.821375000	0.829977007	0.837584494
0.2	0.681000000	0.707795377	0.719226253	0.729641890
0.3	0.605867800	0.633776590	0.646115227	0.657580377
0.4	0.559628676	0.587454526	0.600045701	0.611901791
0.5	0.535376972	0.562906169	0.575556391	0.587575491
0.6	0.529820120	0.557143535	0.569824171	0.581942225
0.7	0.541467455	0.568716935	0.581435423	0.593629526
0.8	0.569732776	0.596951988	0.609684903	0.621907458
0.9	0.614392311	0.641457729	0.654110862	0.666250842
1.0	0.675192037	0.701764495	0.714151626	0.726015790

Table 3.1.4. Errors in approximate solutions of  $y' = -2y^2 + xy + x^2$ ,  $y(0) = 1$ , obtained by Euler's method.

$x$	$h = 0.1$	$h = 0.05$	$h = 0.025$
0.1	0.0376	0.0162	0.0076
0.2	0.0486	0.0218	0.0104
0.3	0.0517	0.0238	0.0115
0.4	0.0523	0.0244	0.0119
0.5	0.0522	0.0247	0.0121
0.6	0.0521	0.0248	0.0121
0.7	0.0522	0.0249	0.0122
0.8	0.0522	0.0250	0.0122
0.9	0.0519	0.0248	0.0121
1.0	0.0508	0.0243	0.0119

**Truncation Error in Euler's Method**

Consistent with the results indicated in Tables 3.1.1–3.1.4, we'll now show that under reasonable assumptions on  $f$  there's a constant  $K$  such that the error in approximating the solution of the initial value problem

$$y' = f(x, y), \quad y(x_0) = y_0,$$

at a given point  $b > x_0$  by Euler's method with step size  $h = (b - x_0)/n$  satisfies the inequality

$$|y(b) - y_n| \leq Kh,$$

where  $K$  is a constant independent of  $n$ .

There are two sources of error (not counting roundoff) in Euler's method:

1. The error committed in approximating the integral curve by the tangent line (3.1.2) over the interval  $[x_i, x_{i+1}]$ .
2. The error committed in replacing  $y(x_i)$  by  $y_i$  in (3.1.2) and using (3.1.4) rather than (3.1.2) to compute  $y_{i+1}$ .

Euler's method assumes that  $y_{i+1}$  defined in (3.1.2) is an approximation to  $y(x_{i+1})$ . We call the error in this approximation the *local truncation error at the  $i$ th step*, and denote it by  $T_i$ ; thus,

$$T_i = y(x_{i+1}) - y(x_i) - hf(x_i, y(x_i)). \quad (3.1.8)$$

We'll now use *Taylor's theorem* to estimate  $T_i$ , assuming for simplicity that  $f$ ,  $f_x$ , and  $f_y$  are continuous and bounded for all  $(x, y)$ . Then  $y''$  exists and is bounded on  $[x_0, b]$ . To see this, we differentiate

$$y'(x) = f(x, y(x))$$

to obtain

$$\begin{aligned} y''(x) &= f_x(x, y(x)) + f_y(x, y(x))y'(x) \\ &= f_x(x, y(x)) + f_y(x, y(x))f(x, y(x)). \end{aligned}$$

Since we assumed that  $f$ ,  $f_x$  and  $f_y$  are bounded, there's a constant  $M$  such that

$$|f_x(x, y(x)) + f_y(x, y(x))f(x, y(x))| \leq M, \quad x_0 < x < b,$$

which implies that

$$|y''(x)| \leq M, \quad x_0 < x < b. \quad (3.1.9)$$

Since  $x_{i+1} = x_i + h$ , Taylor's theorem implies that

$$y(x_{i+1}) = y(x_i) + hy'(x_i) + \frac{h^2}{2}y''(\tilde{x}_i),$$

where  $\tilde{x}_i$  is some number between  $x_i$  and  $x_{i+1}$ . Since  $y'(x_i) = f(x_i, y(x_i))$  this can be written as

$$y(x_{i+1}) = y(x_i) + hf(x_i, y(x_i)) + \frac{h^2}{2}y''(\tilde{x}_i),$$

or, equivalently,

$$y(x_{i+1}) - y(x_i) - hf(x_i, y(x_i)) = \frac{h^2}{2}y''(\tilde{x}_i).$$

Comparing this with (3.1.8) shows that

$$T_i = \frac{h^2}{2}y''(\tilde{x}_i).$$

Recalling (3.1.9), we can establish the bound

$$|T_i| \leq \frac{Mh^2}{2}, \quad 1 \leq i \leq n. \quad (3.1.10)$$

Although it may be difficult to determine the constant  $M$ , what is important is that there's an  $M$  such that (3.1.10) holds. We say that the local truncation error of Euler's method is *of order*  $h^2$ , which we write as  $O(h^2)$ .

Note that the magnitude of the local truncation error in Euler's method is determined by the second derivative  $y''$  of the solution of the initial value problem. Therefore the local truncation error will be larger where  $|y''|$  is large, or smaller where  $|y''|$  is small.

Since the local truncation error for Euler's method is  $O(h^2)$ , it's reasonable to expect that halving  $h$  reduces the local truncation error by a factor of 4. This is true, but halving the step size also requires twice as many steps to approximate the solution at a given point. To analyze the overall effect of truncation error in Euler's method, it's useful to derive an equation relating the errors

$$e_{i+1} = y(x_{i+1}) - y_{i+1} \quad \text{and} \quad e_i = y(x_i) - y_i.$$

To this end, recall that

$$y(x_{i+1}) = y(x_i) + hf(x_i, y(x_i)) + T_i \quad (3.1.11)$$

and

$$y_{i+1} = y_i + hf(x_i, y_i). \quad (3.1.12)$$

Subtracting (3.1.12) from (3.1.11) yields

$$e_{i+1} = e_i + h[f(x_i, y(x_i)) - f(x_i, y_i)] + T_i. \quad (3.1.13)$$

The last term on the right is the local truncation error at the  $i$ th step. The other terms reflect the way errors made at *previous steps* affect  $e_{i+1}$ . Since  $|T_i| \leq Mh^2/2$ , we see from (3.1.13) that

$$|e_{i+1}| \leq |e_i| + h|f(x_i, y(x_i)) - f(x_i, y_i)| + \frac{Mh^2}{2}. \quad (3.1.14)$$

Since we assumed that  $f_y$  is continuous and bounded, the mean value theorem implies that

$$f(x_i, y(x_i)) - f(x_i, y_i) = f_y(x_i, y_i^*)(y(x_i) - y_i) = f_y(x_i, y_i^*)e_i,$$

where  $y_i^*$  is between  $y_i$  and  $y(x_i)$ . Therefore

$$|f(x_i, y(x_i)) - f(x_i, y_i)| \leq R|e_i|$$

for some constant  $R$ . From this and (3.1.14),

$$|e_{i+1}| \leq (1 + Rh)|e_i| + \frac{Mh^2}{2}, \quad 0 \leq i \leq n-1. \quad (3.1.15)$$

For convenience, let  $C = 1 + Rh$ . Since  $e_0 = y(x_0) - y_0 = 0$ , applying (3.1.15) repeatedly yields

$$\begin{aligned} |e_1| &\leq \frac{Mh^2}{2} \\ |e_2| &\leq C|e_1| + \frac{Mh^2}{2} \leq (1 + C)\frac{Mh^2}{2} \\ |e_3| &\leq C|e_2| + \frac{Mh^2}{2} \leq (1 + C + C^2)\frac{Mh^2}{2} \\ &\vdots \\ |e_n| &\leq C|e_{n-1}| + \frac{Mh^2}{2} \leq (1 + C + \cdots + C^{n-1})\frac{Mh^2}{2}. \end{aligned} \quad (3.1.16)$$

Recalling the formula for the sum of a geometric series, we see that

$$1 + C + \cdots + C^{n-1} = \frac{1 - C^n}{1 - C} = \frac{(1 + Rh)^n - 1}{Rh}$$

(since  $C = 1 + Rh$ ). From this and (3.1.16),

$$|y(b) - y_n| = |e_n| \leq \frac{(1 + Rh)^n - 1}{R} \frac{Mh}{2}. \quad (3.1.17)$$

Since Taylor's theorem implies that

$$1 + Rh < e^{Rh}$$

(verify),

$$(1 + Rh)^n < e^{nRh} = e^{R(b-x_0)} \quad (\text{since } nh = b - x_0).$$

This and (3.1.17) imply that

$$|y(b) - y_n| \leq Kh, \quad (3.1.18)$$

with

$$K = M \frac{e^{R(b-x_0)} - 1}{2R}.$$

Because of (3.1.18) we say that the *global truncation error of Euler's method is of order  $h$* , which we write as  $O(h)$ .

### Semilinear Equations and Variation of Parameters

An equation that can be written in the form

$$y' + p(x)y = h(x, y) \quad (3.1.19)$$

with  $p \neq 0$  is said to be *semilinear*. (Of course, (3.1.19) is linear if  $h$  is independent of  $y$ .) One way to apply Euler's method to an initial value problem

$$y' + p(x)y = h(x, y), \quad y(x_0) = y_0 \quad (3.1.20)$$

for (3.1.19) is to think of it as

$$y' = f(x, y), \quad y(x_0) = y_0,$$

where

$$f(x, y) = -p(x)y + h(x, y).$$

However, we can also start by applying variation of parameters to (3.1.20), as in Sections 2.1 and 2.4; thus, we write the solution of (3.1.20) as  $y = uy_1$ , where  $y_1$  is a nontrivial solution of the complementary equation  $y' + p(x)y = 0$ . Then  $y = uy_1$  is a solution of (3.1.20) if and only if  $u$  is a solution of the initial value problem

$$u' = h(x, uy_1(x))/y_1(x), \quad u(x_0) = y(x_0)/y_1(x_0). \quad (3.1.21)$$

We can apply Euler's method to obtain approximate values  $u_0, u_1, \dots, u_n$  of this initial value problem, and then take

$$y_i = u_i y_1(x_i)$$

as approximate values of the solution of (3.1.20). We'll call this procedure the *Euler semilinear method*.

The next two examples show that the Euler and Euler semilinear methods may yield drastically different results.

**Example 3.1.4** In Example 2.1.7 we had to leave the solution of the initial value problem

$$y' - 2xy = 1, \quad y(0) = 3 \quad (3.1.22)$$

in the form

$$y = e^{x^2} \left( 3 + \int_0^x e^{-t^2} dt \right) \quad (3.1.23)$$

because it was impossible to evaluate this integral exactly in terms of elementary functions. Use step sizes  $h = 0.2$ ,  $h = 0.1$ , and  $h = 0.05$  to find approximate values of the solution of (3.1.22) at  $x = 0, 0.2, 0.4, 0.6, \dots, 2.0$  by (a) Euler's method; (b) the Euler semilinear method.

**SOLUTION(a)** Rewriting (3.1.22) as

$$y' = 1 + 2xy, \quad y(0) = 3 \quad (3.1.24)$$

and applying Euler's method with  $f(x, y) = 1 + 2xy$  yields the results shown in Table 3.1.5. Because of the large differences between the estimates obtained for the three values of  $h$ , it would be clear that these results are useless even if the "exact" values were not included in the table.

Table 3.1.5. Numerical solution of  $y' - 2xy = 1$ ,  $y(0) = 3$ , with Euler's method.

$x$	$h = 0.2$	$h = 0.1$	$h = 0.05$	"Exact"
0.0	3.000000000	3.000000000	3.000000000	3.000000000
0.2	3.200000000	3.262000000	3.294348537	3.327851973
0.4	3.656000000	3.802028800	3.881421103	3.966059348
0.6	4.440960000	4.726810214	4.888870783	5.067039535
0.8	5.706790400	6.249191282	6.570796235	6.936700945
1.0	7.732963328	8.771893026	9.419105620	10.184923955
1.2	11.026148659	13.064051391	14.405772067	16.067111677
1.4	16.518700016	20.637273893	23.522935872	27.289392347
1.6	25.969172024	34.570423758	41.033441257	50.000377775
1.8	42.789442120	61.382165543	76.491018246	98.982969504
2.0	73.797840446	115.440048291	152.363866569	211.954462214

It's easy to see why Euler's method yields such poor results. Recall that the constant  $M$  in (3.1.10) – which plays an important role in determining the local truncation error in Euler's method – must be an upper bound for the values of the second derivative  $y''$  of the solution of the initial value problem (3.1.22) on  $(0, 2)$ . The problem is that  $y''$  assumes very large values on this interval. To see this, we differentiate (3.1.24) to obtain

$$y''(x) = 2y(x) + 2xy'(x) = 2y(x) + 2x(1 + 2xy(x)) = 2(1 + 2x^2)y(x) + 2x,$$

where the second equality follows again from (3.1.24). Since (3.1.23) implies that  $y(x) > 3e^{x^2}$  if  $x > 0$ ,

$$y''(x) > 6(1 + 2x^2)e^{x^2} + 2x, \quad x > 0.$$

For example, letting  $x = 2$  shows that  $y''(2) > 2952$ .

**SOLUTION(b)** Since  $y_1 = e^{x^2}$  is a solution of the complementary equation  $y' - 2xy = 0$ , we can apply the Euler semilinear method to (3.1.22), with

$$y = ue^{x^2} \quad \text{and} \quad u' = e^{-x^2}, \quad u(0) = 3.$$

The results listed in Table 3.1.6 are clearly better than those obtained by Euler's method.

Table 3.1.6. Numerical solution of  $y' - 2xy = 1$ ,  $y(0) = 3$ , by the Euler semilinear method.

$x$	$h = 0.2$	$h = 0.1$	$h = 0.05$	“Exact”
0.0	3.000000000	3.000000000	3.000000000	3.000000000
0.2	3.330594477	3.329558853	3.328788889	3.327851973
0.4	3.980734157	3.974067628	3.970230415	3.966059348
0.6	5.106360231	5.087705244	5.077622723	5.067039535
0.8	7.021003417	6.980190891	6.958779586	6.936700945
1.0	10.350076600	10.269170824	10.227464299	10.184923955
1.2	16.381180092	16.226146390	16.147129067	16.067111677
1.4	27.890003380	27.592026085	27.441292235	27.289392347
1.6	51.183323262	50.594503863	50.298106659	50.000377775
1.8	101.424397595	100.206659076	99.595562766	98.982969504
2.0	217.301032800	214.631041938	213.293582978	211.954462214

We can't give a general procedure for determining in advance whether Euler's method or the semilinear Euler method will produce better results for a given semilinear initial value problem (3.1.19). As a rule of thumb, the Euler semilinear method will yield better results than Euler's method if  $|u''|$  is small on  $[x_0, b]$ , while Euler's method yields better results if  $|u'|$  is large on  $[x_0, b]$ . In many cases the results obtained by the two methods don't differ appreciably. However, we propose the an intuitive way to decide which is the better method: Try both methods with multiple step sizes, as we did in Example 3.1.4, and accept the results obtained by the method for which the approximations change less as the step size decreases.

**Example 3.1.5** Applying Euler's method with step sizes  $h = 0.1$ ,  $h = 0.05$ , and  $h = 0.025$  to the initial value problem

$$y' - 2y = \frac{x}{1+y^2}, \quad y(1) = 7 \quad (3.1.25)$$

on  $[1, 2]$  yields the results in Table 3.1.7. Applying the Euler semilinear method with

$$y = ue^{2x} \quad \text{and} \quad u' = \frac{xe^{-2x}}{1+u^2e^{4x}}, \quad u(1) = 7e^{-2}$$

yields the results in Table 3.1.8. Since the latter are clearly less dependent on step size than the former, we conclude that the Euler semilinear method is better than Euler's method for (3.1.25). This conclusion is supported by comparing the approximate results obtained by the two methods with the “exact” values of the solution.

Table 3.1.7. Numerical solution of  $y' - 2y = x/(1+y^2)$ ,  $y(1) = 7$ , by Euler's method.

$x$	$h = 0.1$	$h = 0.05$	$h = 0.025$	“Exact”
1.0	7.000000000	7.000000000	7.000000000	7.000000000
1.1	8.402000000	8.471970569	8.510493955	8.551744786
1.2	10.083936450	10.252570169	10.346014101	10.446546230
1.3	12.101892354	12.406719381	12.576720827	12.760480158
1.4	14.523152445	15.012952416	15.287872104	15.586440425
1.5	17.428443554	18.166277405	18.583079406	19.037865752
1.6	20.914624471	21.981638487	22.588266217	23.253292359
1.7	25.097914310	26.598105180	27.456479695	28.401914416
1.8	30.117766627	32.183941340	33.373738944	34.690375086
1.9	36.141518172	38.942738252	40.566143158	42.371060528
2.0	43.369967155	47.120835251	49.308511126	51.752229656

Table 3.1.8. Numerical solution of  $y' - 2y = x/(1 + y^2)$ ,  $y(1) = 7$ , by the Euler semilinear method.

$x$	$h = 0.1$	$h = 0.05$	$h = 0.025$	"Exact"
1.0	7.000000000	7.000000000	7.000000000	7.000000000
1.1	8.552262113	8.551993978	8.551867007	8.551744786
1.2	10.447568674	10.447038547	10.446787646	10.446546230
1.3	12.762019799	12.761221313	12.760843543	12.760480158
1.4	15.588535141	15.587448600	15.586934680	15.586440425
1.5	19.040580614	19.039172241	19.038506211	19.037865752
1.6	23.256721636	23.254942517	23.254101253	23.253292359
1.7	28.406184597	28.403969107	28.402921581	28.401914416
1.8	34.695649222	34.692912768	34.691618979	34.690375086
1.9	42.377544138	42.374180090	42.372589624	42.371060528
2.0	51.760178446	51.756054133	51.754104262	51.752229656

**Example 3.1.6** Applying Euler's method with step sizes  $h = 0.1$ ,  $h = 0.05$ , and  $h = 0.025$  to the initial value problem

$$y' + 3x^2y = 1 + y^2, \quad y(2) = 2 \tag{3.1.26}$$

on  $[2, 3]$  yields the results in Table 3.1.9. Applying the Euler semilinear method with

$$y = ue^{-x^3} \quad \text{and} \quad u' = e^{x^3}(1 + u^2e^{-2x^3}), \quad u(2) = 2e^8$$

yields the results in Table 3.1.10. Noting the close agreement among the three columns of Table 3.1.9 (at least for larger values of  $x$ ) and the lack of any such agreement among the columns of Table 3.1.10, we conclude that Euler's method is better than the Euler semilinear method for (3.1.26). Comparing the results with the exact values supports this conclusion.

Table 3.1.9. Numerical solution of  $y' + 3x^2y = 1 + y^2$ ,  $y(2) = 2$ , by Euler's method.

$x$	$h = 0.1$	$h = 0.05$	$h = 0.025$	"Exact"
2.0	2.000000000	2.000000000	2.000000000	2.000000000
2.1	0.100000000	0.493231250	0.609611171	0.701162906
2.2	0.068700000	0.122879586	0.180113445	0.236986800
2.3	0.069419569	0.070670890	0.083934459	0.103815729
2.4	0.059732621	0.061338956	0.063337561	0.068390786
2.5	0.056871451	0.056002363	0.056249670	0.057281091
2.6	0.050560917	0.051465256	0.051517501	0.051711676
2.7	0.048279018	0.047484716	0.047514202	0.047564141
2.8	0.042925892	0.043967002	0.043989239	0.044014438
2.9	0.042148458	0.040839683	0.040857109	0.040875333
3.0	0.035985548	0.038044692	0.038058536	0.038072838

Table 3.1.10. Numerical solution of  $y' + 3x^2y = 1 + y^2$ ,  $y(2) = 2$ , by the Euler semilinear method.

$x$	$h = 0.1$	$h = 0.05$	$h = 0.025$	"Exact"
$x$	$h = 0.1$	$h = 0.05$	$h = 0.025$	$h = .0125$
2.0	2.000000000	2.000000000	2.000000000	2.000000000
2.1	0.708426286	0.702568171	0.701214274	0.701162906
2.2	0.214501852	0.222599468	0.228942240	0.236986800
2.3	0.069861436	0.083620494	0.092852806	0.103815729
2.4	0.032487396	0.047079261	0.056825805	0.068390786
2.5	0.021895559	0.036030018	0.045683801	0.057281091
2.6	0.017332058	0.030750181	0.040189920	0.051711676
2.7	0.014271492	0.026931911	0.036134674	0.047564141
2.8	0.011819555	0.023720670	0.032679767	0.044014438
2.9	0.009776792	0.020925522	0.029636506	0.040875333
3.0	0.008065020	0.018472302	0.026931099	0.038072838

In the next two sections we'll study other numerical methods for solving initial value problems, called the *improved Euler method*, the *midpoint method*, *Heun's method* and the *Runge-Kutta method*. If the initial value problem is semilinear as in (3.1.19), we also have the option of using variation of parameters and then applying the given numerical method to the initial value problem (3.1.21) for  $u$ . By analogy with the terminology used here, we'll call the resulting procedure *the improved Euler semilinear method*, the *midpoint semilinear method*, *Heun's semilinear method* or *the Runge-Kutta semilinear method*, as the case may be.

### 3.1 Exercises

You may want to save the results of these exercises, since we'll revisit in the next two sections. In Exercises 1–5 use Euler's method to find approximate values of the solution of the given initial value problem at the points  $x_i = x_0 + ih$ , where  $x_0$  is the point where the initial condition is imposed and  $i = 1, 2, 3$ . The purpose of these exercises is to familiarize you with the computational procedure of Euler's method.

- $y' = 2x^2 + 3y^2 - 2$ ,  $y(2) = 1$ ;  $h = 0.05$
- $y' = y + \sqrt{x^2 + y^2}$ ,  $y(0) = 1$ ;  $h = 0.1$
- $y' + 3y = x^2 - 3xy + y^2$ ,  $y(0) = 2$ ;  $h = 0.05$
- $y' = \frac{1+x}{1-y^2}$ ,  $y(2) = 3$ ;  $h = 0.1$
- $y' + x^2y = \sin xy$ ,  $y(1) = \pi$ ;  $h = 0.2$
- Use Euler's method with step sizes  $h = 0.1$ ,  $h = 0.05$ , and  $h = 0.025$  to find approximate values of the solution of the initial value problem

$$y' + 3y = 7e^{4x}, \quad y(0) = 2$$

at  $x = 0, 0.1, 0.2, 0.3, \dots, 1.0$ . Compare these approximate values with the values of the exact solution  $y = e^{4x} + e^{-3x}$ , which can be obtained by the method of Section 2.1. Present your results in a table like Table 3.1.1.

- Use Euler's method with step sizes  $h = 0.1$ ,  $h = 0.05$ , and  $h = 0.025$  to find approximate values of the solution of the initial value problem

$$y' + \frac{2}{x}y = \frac{3}{x^3} + 1, \quad y(1) = 1$$



at  $x = 1.0, 1.1, 1.2, 1.3, \dots, 2.0$ . Compare these approximate values with the values of the exact solution

$$y = \frac{1}{3x^2}(9 \ln x + x^3 + 2),$$

which can be obtained by the method of Section 2.1. Present your results in a table like Table 3.1.1.

8. C Use Euler's method with step sizes  $h = 0.05$ ,  $h = 0.025$ , and  $h = 0.0125$  to find approximate values of the solution of the initial value problem

$$y' = \frac{y^2 + xy - x^2}{x^2}, \quad y(1) = 2$$

at  $x = 1.0, 1.05, 1.10, 1.15, \dots, 1.5$ . Compare these approximate values with the values of the exact solution

$$y = \frac{x(1 + x^2/3)}{1 - x^2/3}$$

obtained in Example 2.4.3. Present your results in a table like Table 3.1.1.

9. C In Example 2.2.3 it was shown that

$$y^5 + y = x^2 + x - 4$$

is an implicit solution of the initial value problem

$$y' = \frac{2x + 1}{5y^4 + 1}, \quad y(2) = 1. \quad (\text{A})$$

Use Euler's method with step sizes  $h = 0.1$ ,  $h = 0.05$ , and  $h = 0.025$  to find approximate values of the solution of (A) at  $x = 2.0, 2.1, 2.2, 2.3, \dots, 3.0$ . Present your results in tabular form. To check the error in these approximate values, construct another table of values of the residual

$$R(x, y) = y^5 + y - x^2 - x + 4$$

for each value of  $(x, y)$  appearing in the first table.

10. C You can see from Example 2.5.1 that

$$x^4y^3 + x^2y^5 + 2xy = 4$$

is an implicit solution of the initial value problem

$$y' = -\frac{4x^3y^3 + 2xy^5 + 2y}{3x^4y^2 + 5x^2y^4 + 2x}, \quad y(1) = 1. \quad (\text{A})$$

Use Euler's method with step sizes  $h = 0.1$ ,  $h = 0.05$ , and  $h = 0.025$  to find approximate values of the solution of (A) at  $x = 1.0, 1.1, 1.2, 1.3, \dots, 2.0$ . Present your results in tabular form. To check the error in these approximate values, construct another table of values of the residual

$$R(x, y) = x^4y^3 + x^2y^5 + 2xy - 4$$

for each value of  $(x, y)$  appearing in the first table.

11. C Use Euler's method with step sizes  $h = 0.1$ ,  $h = 0.05$ , and  $h = 0.025$  to find approximate values of the solution of the initial value problem

$$(3y^2 + 4y)y' + 2x + \cos x = 0, \quad y(0) = 1; \quad (\text{Exercise 2.2.13})$$

at  $x = 0, 0.1, 0.2, 0.3, \dots, 1.0$ .

12.  Use Euler's method with step sizes  $h = 0.1$ ,  $h = 0.05$ , and  $h = 0.025$  to find approximate values of the solution of the initial value problem

$$y' + \frac{(y+1)(y-1)(y-2)}{x+1} = 0, \quad y(1) = 0 \quad (\text{Exercise 2.2.14})$$

at  $x = 1.0, 1.1, 1.2, 1.3, \dots, 2.0$ .

13.  Use Euler's method and the Euler semilinear method with step sizes  $h = 0.1$ ,  $h = 0.05$ , and  $h = 0.025$  to find approximate values of the solution of the initial value problem

$$y' + 3y = 7e^{-3x}, \quad y(0) = 6$$

at  $x = 0, 0.1, 0.2, 0.3, \dots, 1.0$ . Compare these approximate values with the values of the exact solution  $y = e^{-3x}(7x + 6)$ , which can be obtained by the method of Section 2.1. Do you notice anything special about the results? Explain.

*The linear initial value problems in Exercises 14–19 can't be solved exactly in terms of known elementary functions. In each exercise, use Euler's method and the Euler semilinear methods with the indicated step sizes to find approximate values of the solution of the given initial value problem at 11 equally spaced points (including the endpoints) in the interval.*

14.   $y' - 2y = \frac{1}{1+x^2}$ ,  $y(2) = 2$ ;  $h = 0.1, 0.05, 0.025$  on  $[2, 3]$
15.   $y' + 2xy = x^2$ ,  $y(0) = 3$  (Exercise 2.1.38);  $h = 0.2, 0.1, 0.05$  on  $[0, 2]$
16.   $y' + \frac{1}{x}y = \frac{\sin x}{x^2}$ ,  $y(1) = 2$ ; (Exercise 2.1.39);  $h = 0.2, 0.1, 0.05$  on  $[1, 3]$
17.   $y' + y = \frac{e^{-x} \tan x}{x}$ ,  $y(1) = 0$ ; (Exercise 2.1.40);  $h = 0.05, 0.025, 0.0125$  on  $[1, 1.5]$
18.   $y' + \frac{2x}{1+x^2}y = \frac{e^x}{(1+x^2)^2}$ ,  $y(0) = 1$ ; (Exercise 2.1.41);  $h = 0.2, 0.1, 0.05$  on  $[0, 2]$
19.   $xy' + (x+1)y = e^{x^2}$ ,  $y(1) = 2$ ; (Exercise 2.1.42);  $h = 0.05, 0.025, 0.0125$  on  $[1, 1.5]$

*In Exercises 20–22, use Euler's method and the Euler semilinear method with the indicated step sizes to find approximate values of the solution of the given initial value problem at 11 equally spaced points (including the endpoints) in the interval.*

20.   $y' + 3y = xy^2(y+1)$ ,  $y(0) = 1$ ;  $h = 0.1, 0.05, 0.025$  on  $[0, 1]$
21.   $y' - 4y = \frac{x}{y^2(y+1)}$ ,  $y(0) = 1$ ;  $h = 0.1, 0.05, 0.025$  on  $[0, 1]$
22.   $y' + 2y = \frac{x^2}{1+y^2}$ ,  $y(2) = 1$ ;  $h = 0.1, 0.05, 0.025$  on  $[2, 3]$
23. NUMERICAL QUADRATURE. The fundamental theorem of calculus says that if  $f$  is continuous on a closed interval  $[a, b]$  then it has an antiderivative  $F$  such that  $F'(x) = f(x)$  on  $[a, b]$  and

$$\int_a^b f(x) dx = F(b) - F(a). \quad (\text{A})$$

This solves the problem of evaluating a definite integral if the integrand  $f$  has an antiderivative that can be found and evaluated easily. However, if  $f$  doesn't have this property, (A) doesn't provide

a useful way to evaluate the definite integral. In this case we must resort to approximate methods. There's a class of such methods called *numerical quadrature*, where the approximation takes the form

$$\int_a^b f(x) dx \approx \sum_{i=0}^n c_i f(x_i), \quad (\text{B})$$

where  $a = x_0 < x_1 < \dots < x_n = b$  are suitably chosen points and  $c_0, c_1, \dots, c_n$  are suitably chosen constants. We call (B) a *quadrature formula*.

(a) Derive the quadrature formula

$$\int_a^b f(x) dx \approx h \sum_{i=0}^{n-1} f(a + ih) \quad (\text{where } h = (b - a)/n) \quad (\text{C})$$

by applying Euler's method to the initial value problem

$$y' = f(x), \quad y(a) = 0.$$

- (b) The quadrature formula (C) is sometimes called *the left rectangle rule*. Draw a figure that justifies this terminology.
- (c) **L** For several choices of  $a, b$ , and  $A$ , apply (C) to  $f(x) = A$  with  $n = 10, 20, 40, 80, 160, 320$ . Compare your results with the exact answers and explain what you find.
- (d) **L** For several choices of  $a, b, A$ , and  $B$ , apply (C) to  $f(x) = A + Bx$  with  $n = 10, 20, 40, 80, 160, 320$ . Compare your results with the exact answers and explain what you find.

### 3.2 THE IMPROVED EULER METHOD AND RELATED METHODS

In Section 3.1 we saw that the global truncation error of Euler's method is  $O(h)$ , which would seem to imply that we can achieve arbitrarily accurate results with Euler's method by simply choosing the step size sufficiently small. However, this isn't a good idea, for two reasons. First, after a certain point decreasing the step size will increase roundoff errors to the point where the accuracy will deteriorate rather than improve. The second and more important reason is that in most applications of numerical methods to an initial value problem

$$y' = f(x, y), \quad y(x_0) = y_0, \quad (3.2.1)$$

the expensive part of the computation is the evaluation of  $f$ . Therefore we want methods that give good results for a given number of such evaluations. This is what motivates us to look for numerical methods better than Euler's.

To clarify this point, suppose we want to approximate the value of  $e$  by applying Euler's method to the initial value problem

$$y' = y, \quad y(0) = 1, \quad (\text{with solution } y = e^x)$$

on  $[0, 1]$ , with  $h = 1/12, 1/24$ , and  $1/48$ , respectively. Since each step in Euler's method requires one evaluation of  $f$ , the number of evaluations of  $f$  in each of these attempts is  $n = 12, 24$ , and  $48$ , respectively. In each case we accept  $y_n$  as an approximation to  $e$ . The second column of Table 3.2.1 shows the results. The first column of the table indicates the number of evaluations of  $f$  required to obtain the approximation, and the last column contains the value of  $e$  rounded to ten significant figures.

In this section we'll study the *improved Euler method*, which requires two evaluations of  $f$  at each step. We've used this method with  $h = 1/6, 1/12$ , and  $1/24$ . The required number of evaluations of  $f$

were 12, 24, and 48, as in the three applications of Euler's method; however, you can see from the third column of Table 3.2.1 that the approximation to  $e$  obtained by the improved Euler method with only 12 evaluations of  $f$  is better than the approximation obtained by Euler's method with 48 evaluations.

In Section 3.1 we'll study the *Runge-Kutta method*, which requires four evaluations of  $f$  at each step. We've used this method with  $h = 1/3, 1/6,$  and  $1/12$ . The required number of evaluations of  $f$  were again 12, 24, and 48, as in the three applications of Euler's method and the improved Euler method; however, you can see from the fourth column of Table 3.2.1 that the approximation to  $e$  obtained by the Runge-Kutta method with only 12 evaluations of  $f$  is better than the approximation obtained by the improved Euler method with 48 evaluations.

Table 3.2.1. Approximations to  $e$  obtained by three numerical methods.

$n$	Euler	Improved Euler	Runge-Kutta	Exact
12	2.613035290	2.707188994	2.718069764	2.718281828
24	2.663731258	2.715327371	2.718266612	2.718281828
48	2.690496599	2.717519565	2.718280809	2.718281828

### The Improved Euler Method

The *improved Euler method* for solving the initial value problem (3.2.1) is based on approximating the integral curve of (3.2.1) at  $(x_i, y(x_i))$  by the line through  $(x_i, y(x_i))$  with slope

$$m_i = \frac{f(x_i, y(x_i)) + f(x_{i+1}, y(x_{i+1}))}{2};$$

that is,  $m_i$  is the average of the slopes of the tangents to the integral curve at the endpoints of  $[x_i, x_{i+1}]$ . The equation of the approximating line is therefore

$$y = y(x_i) + \frac{f(x_i, y(x_i)) + f(x_{i+1}, y(x_{i+1}))}{2}(x - x_i). \quad (3.2.2)$$

Setting  $x = x_{i+1} = x_i + h$  in (3.2.2) yields

$$y_{i+1} = y(x_i) + \frac{h}{2}(f(x_i, y(x_i)) + f(x_{i+1}, y(x_{i+1}))) \quad (3.2.3)$$

as an approximation to  $y(x_{i+1})$ . As in our derivation of Euler's method, we replace  $y(x_i)$  (unknown if  $i > 0$ ) by its approximate value  $y_i$ ; then (3.2.3) becomes

$$y_{i+1} = y_i + \frac{h}{2}(f(x_i, y_i) + f(x_{i+1}, y(x_{i+1}))).$$

However, this still won't work, because we don't know  $y(x_{i+1})$ , which appears on the right. We overcome this by replacing  $y(x_{i+1})$  by  $y_i + hf(x_i, y_i)$ , the value that the Euler method would assign to  $y_{i+1}$ . Thus, the improved Euler method starts with the known value  $y(x_0) = y_0$  and computes  $y_1, y_2, \dots, y_n$  successively with the formula

$$y_{i+1} = y_i + \frac{h}{2}(f(x_i, y_i) + f(x_{i+1}, y_i + hf(x_i, y_i))). \quad (3.2.4)$$

The computation indicated here can be conveniently organized as follows: given  $y_i$ , compute

$$\begin{aligned} k_{1i} &= f(x_i, y_i), \\ k_{2i} &= f(x_i + h, y_i + hk_{1i}), \\ y_{i+1} &= y_i + \frac{h}{2}(k_{1i} + k_{2i}). \end{aligned}$$

The improved Euler method requires two evaluations of  $f(x, y)$  per step, while Euler's method requires only one. However, we'll see at the end of this section that if  $f$  satisfies appropriate assumptions, the local truncation error with the improved Euler method is  $O(h^3)$ , rather than  $O(h^2)$  as with Euler's method. Therefore the global truncation error with the improved Euler method is  $O(h^2)$ ; however, we won't prove this.

We note that the magnitude of the local truncation error in the improved Euler method and other methods discussed in this section is determined by the third derivative  $y'''$  of the solution of the initial value problem. Therefore the local truncation error will be larger where  $|y'''|$  is large, or smaller where  $|y'''|$  is small.

The next example, which deals with the initial value problem considered in Example 3.1.1, illustrates the computational procedure indicated in the improved Euler method.

**Example 3.2.1** Use the improved Euler method with  $h = 0.1$  to find approximate values of the solution of the initial value problem

$$y' + 2y = x^3 e^{-2x}, \quad y(0) = 1 \quad (3.2.5)$$

at  $x = 0.1, 0.2, 0.3$ .

**Solution** As in Example 3.1.1, we rewrite (3.2.5) as

$$y' = -2y + x^3 e^{-2x}, \quad y(0) = 1,$$

which is of the form (3.2.1), with

$$f(x, y) = -2y + x^3 e^{-2x}, \quad x_0 = 0, \quad \text{and } y_0 = 1.$$

The improved Euler method yields

$$\begin{aligned} k_{10} &= f(x_0, y_0) = f(0, 1) = -2, \\ k_{20} &= f(x_1, y_0 + hk_{10}) = f(.1, 1 + (.1)(-2)) \\ &= f(.1, .8) = -2(.8) + (.1)^3 e^{-.2} = -1.599181269, \\ y_1 &= y_0 + \frac{h}{2}(k_{10} + k_{20}), \\ &= 1 + (.05)(-2 - 1.599181269) = .820040937, \\ k_{11} &= f(x_1, y_1) = f(.1, .820040937) = -2(.820040937) + (.1)^3 e^{-.2} = -1.639263142, \\ k_{21} &= f(x_2, y_1 + hk_{11}) = f(.2, .820040937 + .1(-1.639263142)), \\ &= f(.2, .656114622) = -2(.656114622) + (.2)^3 e^{-.4} = -1.306866684, \\ y_2 &= y_1 + \frac{h}{2}(k_{11} + k_{21}), \\ &= .820040937 + (.05)(-1.639263142 - 1.306866684) = .672734445, \\ k_{12} &= f(x_2, y_2) = f(.2, .672734445) = -2(.672734445) + (.2)^3 e^{-.4} = -1.340106330, \\ k_{22} &= f(x_3, y_2 + hk_{12}) = f(.3, .672734445 + .1(-1.340106330)), \\ &= f(.3, .538723812) = -2(.538723812) + (.3)^3 e^{-.6} = -1.062629710, \\ y_3 &= y_2 + \frac{h}{2}(k_{12} + k_{22}) \\ &= .672734445 + (.05)(-1.340106330 - 1.062629710) = .552597643. \end{aligned}$$

**Example 3.2.2** Table 3.2.2 shows results of using the improved Euler method with step sizes  $h = 0.1$  and  $h = 0.05$  to find approximate values of the solution of the initial value problem

$$y' + 2y = x^3 e^{-2x}, \quad y(0) = 1$$

at  $x = 0, 0.1, 0.2, 0.3, \dots, 1.0$ . For comparison, it also shows the corresponding approximate values obtained with Euler's method in 3.1.2, and the values of the exact solution

$$y = \frac{e^{-2x}}{4}(x^4 + 4).$$

The results obtained by the improved Euler method with  $h = 0.1$  are better than those obtained by Euler's method with  $h = 0.05$ .

Table 3.2.2. Numerical solution of  $y' + 2y = x^3e^{-2x}$ ,  $y(0) = 1$ , by Euler's method and the improved Euler method.

$x$	$h = 0.1$	$h = 0.05$	$h = 0.1$	$h = 0.05$	Exact
0.0	1.000000000	1.000000000	1.000000000	1.000000000	1.000000000
0.1	0.800000000	0.810005655	0.820040937	0.819050572	0.818751221
0.2	0.640081873	0.656266437	0.672734445	0.671086455	0.670588174
0.3	0.512601754	0.532290981	0.552597643	0.550543878	0.549922980
0.4	0.411563195	0.432887056	0.455160637	0.452890616	0.452204669
0.5	0.332126261	0.353785015	0.376681251	0.374335747	0.373627557
0.6	0.270299502	0.291404256	0.313970920	0.311652239	0.310952904
0.7	0.222745397	0.242707257	0.264287611	0.262067624	0.261398947
0.8	0.186654593	0.205105754	0.225267702	0.223194281	0.222570721
0.9	0.159660776	0.176396883	0.194879501	0.192981757	0.192412038
1.0	0.139778910	0.154715925	0.171388070	0.169680673	0.169169104
	Euler		Improved Euler		Exact

**Example 3.2.3** Table 3.2.3 shows analogous results for the nonlinear initial value problem

$$y' = -2y^2 + xy + x^2, y(0) = 1.$$

We applied Euler's method to this problem in Example 3.1.3.

Table 3.2.3. Numerical solution of  $y' = -2y^2 + xy + x^2$ ,  $y(0) = 1$ , by Euler's method and the improved Euler method.

$x$	$h = 0.1$	$h = 0.05$	$h = 0.1$	$h = 0.05$	"Exact"
0.0	1.000000000	1.000000000	1.000000000	1.000000000	1.000000000
0.1	0.800000000	0.821375000	0.840500000	0.838288371	0.837584494
0.2	0.681000000	0.707795377	0.733430846	0.730556677	0.729641890
0.3	0.605867800	0.633776590	0.661600806	0.658552190	0.657580377
0.4	0.559628676	0.587454526	0.615961841	0.612884493	0.611901791
0.5	0.535376972	0.562906169	0.591634742	0.588558952	0.587575491
0.6	0.529820120	0.557143535	0.586006935	0.582927224	0.581942225
0.7	0.541467455	0.568716935	0.597712120	0.594618012	0.593629526
0.8	0.569732776	0.596951988	0.626008824	0.622898279	0.621907458
0.9	0.614392311	0.641457729	0.670351225	0.667237617	0.666250842
1.0	0.675192037	0.701764495	0.730069610	0.726985837	0.726015790
	Euler		Improved Euler		"Exact"

**Example 3.2.4** Use step sizes  $h = 0.2$ ,  $h = 0.1$ , and  $h = 0.05$  to find approximate values of the solution of

$$y' - 2xy = 1, \quad y(0) = 3 \tag{3.2.6}$$

at  $x = 0, 0.2, 0.4, 0.6, \dots, 2.0$  by **(a)** the improved Euler method; **(b)** the improved Euler semilinear method. (We used Euler's method and the Euler semilinear method on this problem in 3.1.4.)

**SOLUTION(a)** Rewriting (3.2.6) as

$$y' = 1 + 2xy, \quad y(0) = 3$$

and applying the improved Euler method with  $f(x, y) = 1 + 2xy$  yields the results shown in Table 3.2.4.

**SOLUTION(b)** Since  $y_1 = e^{x^2}$  is a solution of the complementary equation  $y' - 2xy = 0$ , we can apply the improved Euler semilinear method to (3.2.6), with

$$y = ue^{x^2} \quad \text{and} \quad u' = e^{-x^2}, \quad u(0) = 3.$$

The results listed in Table 3.2.5 are clearly better than those obtained by the improved Euler method.

Table 3.2.4. Numerical solution of  $y' - 2xy = 1$ ,  $y(0) = 3$ , by the improved Euler method.

$x$	$h = 0.2$	$h = 0.1$	$h = 0.05$	"Exact"
0.0	3.000000000	3.000000000	3.000000000	3.000000000
0.2	3.328000000	3.328182400	3.327973600	3.327851973
0.4	3.964659200	3.966340117	3.966216690	3.966059348
0.6	5.057712497	5.065700515	5.066848381	5.067039535
0.8	6.900088156	6.928648973	6.934862367	6.936700945
1.0	10.065725534	10.154872547	10.177430736	10.184923955
1.2	15.708954420	15.970033261	16.041904862	16.067111677
1.4	26.244894192	26.991620960	27.210001715	27.289392347
1.6	46.958915746	49.096125524	49.754131060	50.000377775
1.8	89.982312641	96.200506218	98.210577385	98.982969504
2.0	184.563776288	203.151922739	209.464744495	211.954462214

Table 3.2.5. Numerical solution of  $y' - 2xy = 1$ ,  $y(0) = 3$ , by the improved Euler semilinear method.

$x$	$h = 0.2$	$h = 0.1$	$h = 0.05$	"Exact"
0.0	3.000000000	3.000000000	3.000000000	3.000000000
0.2	3.326513400	3.327518315	3.327768620	3.327851973
0.4	3.963383070	3.965392084	3.965892644	3.966059348
0.6	5.063027290	5.066038774	5.066789487	5.067039535
0.8	6.931355329	6.935366847	6.936367564	6.936700945
1.0	10.178248417	10.183256733	10.184507253	10.184923955
1.2	16.059110511	16.065111599	16.066611672	16.067111677
1.4	27.280070674	27.287059732	27.288809058	27.289392347
1.6	49.989741531	49.997712997	49.999711226	50.000377775
1.8	98.971025420	98.979972988	98.982219722	98.982969504
2.0	211.941217796	211.951134436	211.953629228	211.954462214

### A Family of Methods with $O(h^3)$ Local Truncation Error

We'll now derive a class of methods with  $O(h^3)$  local truncation error for solving (3.2.1). For simplicity, we assume that  $f$ ,  $f_x$ ,  $f_y$ ,  $f_{xx}$ ,  $f_{yy}$ , and  $f_{xy}$  are continuous and bounded for all  $(x, y)$ . This implies that if  $y$  is the solution of (3.2.1) then  $y''$  and  $y'''$  are bounded (Exercise 31).

We begin by approximating the integral curve of (3.2.1) at  $(x_i, y(x_i))$  by the line through  $(x_i, y(x_i))$  with slope

$$m_i = \sigma y'(x_i) + \rho y'(x_i + \theta h),$$

where  $\sigma$ ,  $\rho$ , and  $\theta$  are constants that we'll soon specify; however, we insist at the outset that  $0 < \theta \leq 1$ , so that

$$x_i < x_i + \theta h \leq x_{i+1}.$$

The equation of the approximating line is

$$\begin{aligned} y &= y(x_i) + m_i(x - x_i) \\ &= y(x_i) + [\sigma y'(x_i) + \rho y'(x_i + \theta h)](x - x_i). \end{aligned} \quad (3.2.7)$$

Setting  $x = x_{i+1} = x_i + h$  in (3.2.7) yields

$$\hat{y}_{i+1} = y(x_i) + h[\sigma y'(x_i) + \rho y'(x_i + \theta h)]$$

as an approximation to  $y(x_{i+1})$ .

To determine  $\sigma$ ,  $\rho$ , and  $\theta$  so that the error

$$\begin{aligned} E_i &= y(x_{i+1}) - \hat{y}_{i+1} \\ &= y(x_{i+1}) - y(x_i) - h[\sigma y'(x_i) + \rho y'(x_i + \theta h)] \end{aligned} \quad (3.2.8)$$

in this approximation is  $O(h^3)$ , we begin by recalling from Taylor's theorem that

$$y(x_{i+1}) = y(x_i) + hy'(x_i) + \frac{h^2}{2}y''(x_i) + \frac{h^3}{6}y'''(\hat{x}_i),$$

where  $\hat{x}_i$  is in  $(x_i, x_{i+1})$ . Since  $y'''$  is bounded this implies that

$$y(x_{i+1}) - y(x_i) - hy'(x_i) - \frac{h^2}{2}y''(x_i) = O(h^3).$$

Comparing this with (3.2.8) shows that  $E_i = O(h^3)$  if

$$\sigma y'(x_i) + \rho y'(x_i + \theta h) = y'(x_i) + \frac{h}{2}y''(x_i) + O(h^2). \quad (3.2.9)$$

However, applying Taylor's theorem to  $y'$  shows that

$$y'(x_i + \theta h) = y'(x_i) + \theta h y''(x_i) + \frac{(\theta h)^2}{2} y'''(\bar{x}_i),$$

where  $\bar{x}_i$  is in  $(x_i, x_i + \theta h)$ . Since  $y'''$  is bounded, this implies that

$$y'(x_i + \theta h) = y'(x_i) + \theta h y''(x_i) + O(h^2).$$

Substituting this into (3.2.9) and noting that the sum of two  $O(h^2)$  terms is again  $O(h^2)$  shows that  $E_i = O(h^3)$  if

$$(\sigma + \rho)y'(x_i) + \rho\theta h y''(x_i) = y'(x_i) + \frac{h}{2}y''(x_i),$$



which is true if

$$\sigma + \rho = 1 \quad \text{and} \quad \rho\theta = \frac{1}{2}. \quad (3.2.10)$$

Since  $y' = f(x, y)$ , we can now conclude from (3.2.8) that

$$y(x_{i+1}) = y(x_i) + h[\sigma f(x_i, y_i) + \rho f(x_i + \theta h, y(x_i + \theta h))] + O(h^3) \quad (3.2.11)$$

if  $\sigma$ ,  $\rho$ , and  $\theta$  satisfy (3.2.10). However, this formula would not be useful even if we knew  $y(x_i)$  exactly (as we would for  $i = 0$ ), since we still wouldn't know  $y(x_i + \theta h)$  exactly. To overcome this difficulty, we again use Taylor's theorem to write

$$y(x_i + \theta h) = y(x_i) + \theta h y'(x_i) + \frac{h^2}{2} y''(\tilde{x}_i),$$

where  $\tilde{x}_i$  is in  $(x_i, x_i + \theta h)$ . Since  $y'(x_i) = f(x_i, y(x_i))$  and  $y''$  is bounded, this implies that

$$|y(x_i + \theta h) - y(x_i) - \theta h f(x_i, y(x_i))| \leq Kh^2 \quad (3.2.12)$$

for some constant  $K$ . Since  $f_y$  is bounded, the mean value theorem implies that

$$|f(x_i + \theta h, u) - f(x_i + \theta h, v)| \leq M|u - v|$$

for some constant  $M$ . Letting

$$u = y(x_i + \theta h) \quad \text{and} \quad v = y(x_i) + \theta h f(x_i, y(x_i))$$

and recalling (3.2.12) shows that

$$f(x_i + \theta h, y(x_i + \theta h)) = f(x_i + \theta h, y(x_i) + \theta h f(x_i, y(x_i))) + O(h^2).$$

Substituting this into (3.2.11) yields

$$\begin{aligned} y(x_{i+1}) &= y(x_i) + h[\sigma f(x_i, y(x_i)) + \\ &\quad \rho f(x_i + \theta h, y(x_i) + \theta h f(x_i, y(x_i)))] + O(h^3). \end{aligned}$$

This implies that the formula

$$y_{i+1} = y_i + h[\sigma f(x_i, y_i) + \rho f(x_i + \theta h, y_i + \theta h f(x_i, y_i))]$$

has  $O(h^3)$  local truncation error if  $\sigma$ ,  $\rho$ , and  $\theta$  satisfy (3.2.10). Substituting  $\sigma = 1 - \rho$  and  $\theta = 1/2\rho$  here yields

$$y_{i+1} = y_i + h \left[ (1 - \rho) f(x_i, y_i) + \rho f \left( x_i + \frac{h}{2\rho}, y_i + \frac{h}{2\rho} f(x_i, y_i) \right) \right]. \quad (3.2.13)$$

The computation indicated here can be conveniently organized as follows: given  $y_i$ , compute

$$\begin{aligned} k_{1i} &= f(x_i, y_i), \\ k_{2i} &= f \left( x_i + \frac{h}{2\rho}, y_i + \frac{h}{2\rho} k_{1i} \right), \\ y_{i+1} &= y_i + h[(1 - \rho)k_{1i} + \rho k_{2i}]. \end{aligned}$$

Consistent with our requirement that  $0 < \theta < 1$ , we require that  $\rho \geq 1/2$ . Letting  $\rho = 1/2$  in (3.2.13) yields the improved Euler method (3.2.4). Letting  $\rho = 3/4$  yields *Heun's method*,

$$y_{i+1} = y_i + h \left[ \frac{1}{4} f(x_i, y_i) + \frac{3}{4} f \left( x_i + \frac{2}{3} h, y_i + \frac{2}{3} h f(x_i, y_i) \right) \right],$$

which can be organized as

$$\begin{aligned}k_{1i} &= f(x_i, y_i), \\k_{2i} &= f\left(x_i + \frac{2h}{3}, y_i + \frac{2h}{3}k_{1i}\right), \\y_{i+1} &= y_i + \frac{h}{4}(k_{1i} + 3k_{2i}).\end{aligned}$$

Letting  $\rho = 1$  yields the *midpoint method*,

$$y_{i+1} = y_i + hf\left(x_i + \frac{h}{2}, y_i + \frac{h}{2}f(x_i, y_i)\right),$$

which can be organized as

$$\begin{aligned}k_{1i} &= f(x_i, y_i), \\k_{2i} &= f\left(x_i + \frac{h}{2}, y_i + \frac{h}{2}k_{1i}\right), \\y_{i+1} &= y_i + hk_{2i}.\end{aligned}$$

Examples involving the midpoint method and Heun's method are given in Exercises 23-30.

### 3.2 Exercises

Most of the following numerical exercises involve initial value problems considered in the exercises in Section 3.1. You'll find it instructive to compare the results that you obtain here with the corresponding results that you obtained in Section 3.1.

In Exercises 1-5 use the improved Euler method to find approximate values of the solution of the given initial value problem at the points  $x_i = x_0 + ih$ , where  $x_0$  is the point where the initial condition is imposed and  $i = 1, 2, 3$ .

- $y' = 2x^2 + 3y^2 - 2$ ,  $y(2) = 1$ ;  $h = 0.05$
- $y' = y + \sqrt{x^2 + y^2}$ ,  $y(0) = 1$ ;  $h = 0.1$
- $y' + 3y = x^2 - 3xy + y^2$ ,  $y(0) = 2$ ;  $h = 0.05$
- $y' = \frac{1+x}{1-y^2}$ ,  $y(2) = 3$ ;  $h = 0.1$
- $y' + x^2y = \sin xy$ ,  $y(1) = \pi$ ;  $h = 0.2$
- Use the improved Euler method with step sizes  $h = 0.1$ ,  $h = 0.05$ , and  $h = 0.025$  to find approximate values of the solution of the initial value problem

$$y' + 3y = 7e^{4x}, \quad y(0) = 2$$

at  $x = 0, 0.1, 0.2, 0.3, \dots, 1.0$ . Compare these approximate values with the values of the exact solution  $y = e^{4x} + e^{-3x}$ , which can be obtained by the method of Section 2.1. Present your results in a table like Table 3.2.2.

- Use the improved Euler method with step sizes  $h = 0.1$ ,  $h = 0.05$ , and  $h = 0.025$  to find approximate values of the solution of the initial value problem

$$y' + \frac{2}{x}y = \frac{3}{x^3} + 1, \quad y(1) = 1$$

at  $x = 1.0, 1.1, 1.2, 1.3, \dots, 2.0$ . Compare these approximate values with the values of the exact solution

$$y = \frac{1}{3x^2}(9 \ln x + x^3 + 2)$$

which can be obtained by the method of Section 2.1. Present your results in a table like Table 3.2.2.

8. **C** Use the improved Euler method with step sizes  $h = 0.05$ ,  $h = 0.025$ , and  $h = 0.0125$  to find approximate values of the solution of the initial value problem

$$y' = \frac{y^2 + xy - x^2}{x^2}, \quad y(1) = 2,$$

at  $x = 1.0, 1.05, 1.10, 1.15, \dots, 1.5$ . Compare these approximate values with the values of the exact solution

$$y = \frac{x(1 + x^2/3)}{1 - x^2/3}$$

obtained in Example 2.4.3. Present your results in a table like Table 3.2.2.

9. **C** In Example 3.2.2 it was shown that

$$y^5 + y = x^2 + x - 4$$

is an implicit solution of the initial value problem

$$y' = \frac{2x + 1}{5y^4 + 1}, \quad y(2) = 1. \quad (\text{A})$$

Use the improved Euler method with step sizes  $h = 0.1$ ,  $h = 0.05$ , and  $h = 0.025$  to find approximate values of the solution of (A) at  $x = 2.0, 2.1, 2.2, 2.3, \dots, 3.0$ . Present your results in tabular form. To check the error in these approximate values, construct another table of values of the residual

$$R(x, y) = y^5 + y - x^2 - x + 4$$

for each value of  $(x, y)$  appearing in the first table.

10. **C** You can see from Example 2.5.1 that

$$x^4 y^3 + x^2 y^5 + 2xy = 4$$

is an implicit solution of the initial value problem

$$y' = -\frac{4x^3 y^3 + 2x y^5 + 2y}{3x^4 y^2 + 5x^2 y^4 + 2x}, \quad y(1) = 1. \quad (\text{A})$$

Use the improved Euler method with step sizes  $h = 0.1$ ,  $h = 0.05$ , and  $h = 0.025$  to find approximate values of the solution of (A) at  $x = 1.0, 1.14, 1.2, 1.3, \dots, 2.0$ . Present your results in tabular form. To check the error in these approximate values, construct another table of values of the residual

$$R(x, y) = x^4 y^3 + x^2 y^5 + 2xy - 4$$

for each value of  $(x, y)$  appearing in the first table.

11. **C** Use the improved Euler method with step sizes  $h = 0.1$ ,  $h = 0.05$ , and  $h = 0.025$  to find approximate values of the solution of the initial value problem

$$(3y^2 + 4y)y' + 2x + \cos x = 0, \quad y(0) = 1 \quad (\text{Exercise 2.2.13})$$

at  $x = 0, 0.1, 0.2, 0.3, \dots, 1.0$ .

12.  Use the improved Euler method with step sizes  $h = 0.1$ ,  $h = 0.05$ , and  $h = 0.025$  to find approximate values of the solution of the initial value problem

$$y' + \frac{(y+1)(y-1)(y-2)}{x+1} = 0, \quad y(1) = 0 \text{ (Exercise 2.2.14)}$$

at  $x = 1.0, 1.1, 1.2, 1.3, \dots, 2.0$ .

13.  Use the improved Euler method and the improved Euler semilinear method with step sizes  $h = 0.1$ ,  $h = 0.05$ , and  $h = 0.025$  to find approximate values of the solution of the initial value problem

$$y' + 3y = e^{-3x}(1 - 2x), \quad y(0) = 2,$$

at  $x = 0, 0.1, 0.2, 0.3, \dots, 1.0$ . Compare these approximate values with the values of the exact solution  $y = e^{-3x}(2 + x - x^2)$ , which can be obtained by the method of Section 2.1. Do you notice anything special about the results? Explain.

*The linear initial value problems in Exercises 14–19 can't be solved exactly in terms of known elementary functions. In each exercise use the improved Euler and improved Euler semilinear methods with the indicated step sizes to find approximate values of the solution of the given initial value problem at 11 equally spaced points (including the endpoints) in the interval.*

14.   $y' - 2y = \frac{1}{1+x^2}$ ,  $y(2) = 2$ ;  $h = 0.1, 0.05, 0.025$  on  $[2, 3]$
15.   $y' + 2xy = x^2$ ,  $y(0) = 3$ ;  $h = 0.2, 0.1, 0.05$  on  $[0, 2]$  (Exercise 2.1.38)
16.   $y' + \frac{1}{x}y = \frac{\sin x}{x^2}$ ,  $y(1) = 2$ ,  $h = 0.2, 0.1, 0.05$  on  $[1, 3]$  (Exercise 2.1.39)
17.   $y' + y = \frac{e^{-x} \tan x}{x}$ ,  $y(1) = 0$ ;  $h = 0.05, 0.025, 0.0125$  on  $[1, 1.5]$  (Exercise 2.1.40),
18.   $y' + \frac{2x}{1+x^2}y = \frac{e^x}{(1+x^2)^2}$ ,  $y(0) = 1$ ;  $h = 0.2, 0.1, 0.05$  on  $[0, 2]$  (Exercise 2.1.41)
19.   $xy' + (x+1)y = e^{x^2}$ ,  $y(1) = 2$ ;  $h = 0.05, 0.025, 0.0125$  on  $[1, 1.5]$  (Exercise 2.1.42)

*In Exercises 20–22 use the improved Euler method and the improved Euler semilinear method with the indicated step sizes to find approximate values of the solution of the given initial value problem at 11 equally spaced points (including the endpoints) in the interval.*

20.   $y' + 3y = xy^2(y+1)$ ,  $y(0) = 1$ ;  $h = 0.1, 0.05, 0.025$  on  $[0, 1]$
21.   $y' - 4y = \frac{x}{y^2(y+1)}$ ,  $y(0) = 1$ ;  $h = 0.1, 0.05, 0.025$  on  $[0, 1]$
22.   $y' + 2y = \frac{x^2}{1+y^2}$ ,  $y(2) = 1$ ;  $h = 0.1, 0.05, 0.025$  on  $[2, 3]$
23.  Do Exercise 7 with “improved Euler method” replaced by “midpoint method.”
24.  Do Exercise 7 with “improved Euler method” replaced by “Heun’s method.”
25.  Do Exercise 8 with “improved Euler method” replaced by “midpoint method.”
26.  Do Exercise 8 with “improved Euler method” replaced by “Heun’s method.”
27.  Do Exercise 11 with “improved Euler method” replaced by “midpoint method.”

28. **C** Do Exercise 11 with “improved Euler method” replaced by “Heun’s method.”
29. **C** Do Exercise 12 with “improved Euler method” replaced by “midpoint method.”
30. **C** Do Exercise 12 with “improved Euler method” replaced by “Heun’s method.”
31. Show that if  $f$ ,  $f_x$ ,  $f_y$ ,  $f_{xx}$ ,  $f_{yy}$ , and  $f_{xy}$  are continuous and bounded for all  $(x, y)$  and  $y$  is the solution of the initial value problem

$$y' = f(x, y), \quad y(x_0) = y_0,$$

then  $y''$  and  $y'''$  are bounded.

32. NUMERICAL QUADRATURE (see Exercise 3.1.23).

(a) Derive the quadrature formula

$$\int_a^b f(x) dx \approx .5h(f(a) + f(b)) + h \sum_{i=1}^{n-1} f(a + ih) \quad (\text{where } h = (b - a)/n) \quad (\text{A})$$

by applying the improved Euler method to the initial value problem

$$y' = f(x), \quad y(a) = 0.$$

- (b) The quadrature formula (A) is called *the trapezoid rule*. Draw a figure that justifies this terminology.
- (c) **L** For several choices of  $a$ ,  $b$ ,  $A$ , and  $B$ , apply (A) to  $f(x) = A + Bx$ , with  $n = 10, 20, 40, 80, 160, 320$ . Compare your results with the exact answers and explain what you find.
- (d) **L** For several choices of  $a$ ,  $b$ ,  $A$ ,  $B$ , and  $C$ , apply (A) to  $f(x) = A + Bx + Cx^2$ , with  $n = 10, 20, 40, 80, 160, 320$ . Compare your results with the exact answers and explain what you find.

### 3.3 THE RUNGE-KUTTA METHOD

In general, if  $k$  is any positive integer and  $f$  satisfies appropriate assumptions, there are numerical methods with local truncation error  $O(h^{k+1})$  for solving an initial value problem

$$y' = f(x, y), \quad y(x_0) = y_0. \quad (3.3.1)$$

Moreover, it can be shown that a method with local truncation error  $O(h^{k+1})$  has global truncation error  $O(h^k)$ . In Sections 3.1 and 3.2 we studied numerical methods where  $k = 1$  and  $k = 2$ . We’ll skip methods for which  $k = 3$  and proceed to the *Runge-Kutta* method, the most widely used method, for which  $k = 4$ . The magnitude of the local truncation error is determined by the fifth derivative  $y^{(5)}$  of the solution of the initial value problem. Therefore the local truncation error will be larger where  $|y^{(5)}|$  is large, or smaller where  $|y^{(5)}|$  is small. The Runge-Kutta method computes approximate values  $y_1, y_2, \dots, y_n$  of the solution of (3.3.1) at  $x_0, x_0 + h, \dots, x_0 + nh$  as follows: Given  $y_i$ , compute

$$\begin{aligned} k_{1i} &= f(x_i, y_i), \\ k_{2i} &= f\left(x_i + \frac{h}{2}, y_i + \frac{h}{2}k_{1i}\right), \\ k_{3i} &= f\left(x_i + \frac{h}{2}, y_i + \frac{h}{2}k_{2i}\right), \\ k_{4i} &= f(x_i + h, y_i + hk_{3i}), \end{aligned}$$

and

$$y_{i+1} = y_i + \frac{h}{6}(k_{1i} + 2k_{2i} + 2k_{3i} + k_{4i}).$$

The next example, which deals with the initial value problem considered in Examples 3.1.1 and 3.2.1, illustrates the computational procedure indicated in the Runge-Kutta method.

**Example 3.3.1** Use the Runge-Kutta method with  $h = 0.1$  to find approximate values for the solution of the initial value problem

$$y' + 2y = x^3 e^{-2x}, \quad y(0) = 1, \quad (3.3.2)$$

at  $x = 0.1, 0.2$ .

**Solution** Again we rewrite (3.3.2) as

$$y' = -2y + x^3 e^{-2x}, \quad y(0) = 1,$$

which is of the form (3.3.1), with

$$f(x, y) = -2y + x^3 e^{-2x}, \quad x_0 = 0, \text{ and } y_0 = 1.$$

The Runge-Kutta method yields

$$\begin{aligned} k_{10} &= f(x_0, y_0) = f(0, 1) = -2, \\ k_{20} &= f(x_0 + h/2, y_0 + hk_{10}/2) = f(.05, 1 + (.05)(-2)) \\ &= f(.05, .9) = -2(.9) + (.05)^3 e^{-.1} = -1.799886895, \\ k_{30} &= f(x_0 + h/2, y_0 + hk_{20}/2) = f(.05, 1 + (.05)(-1.799886895)) \\ &= f(.05, .910005655) = -2(.910005655) + (.05)^3 e^{-.1} = -1.819898206, \\ k_{40} &= f(x_0 + h, y_0 + hk_{30}) = f(.1, 1 + (.1)(-1.819898206)) \\ &= f(.1, .818010179) = -2(.818010179) + (.1)^3 e^{-.2} = -1.635201628, \\ y_1 &= y_0 + \frac{h}{6}(k_{10} + 2k_{20} + 2k_{30} + k_{40}), \\ &= 1 + \frac{.1}{6}(-2 + 2(-1.799886895) + 2(-1.819898206) - 1.635201628) = .818753803, \\ k_{11} &= f(x_1, y_1) = f(.1, .818753803) = -2(.818753803) + (.1)^3 e^{-.2} = -1.636688875, \\ k_{21} &= f(x_1 + h/2, y_1 + hk_{11}/2) = f(.15, .818753803 + (.05)(-1.636688875)) \\ &= f(.15, .736919359) = -2(.736919359) + (.15)^3 e^{-.3} = -1.471338457, \\ k_{31} &= f(x_1 + h/2, y_1 + hk_{21}/2) = f(.15, .818753803 + (.05)(-1.471338457)) \\ &= f(.15, .745186880) = -2(.745186880) + (.15)^3 e^{-.3} = -1.487873498, \\ k_{41} &= f(x_1 + h, y_1 + hk_{31}) = f(.2, .818753803 + (.1)(-1.487873498)) \\ &= f(.2, .669966453) = -2(.669966453) + (.2)^3 e^{-.4} = -1.334570346, \\ y_2 &= y_1 + \frac{h}{6}(k_{11} + 2k_{21} + 2k_{31} + k_{41}), \\ &= .818753803 + \frac{.1}{6}(-1.636688875 + 2(-1.471338457) + 2(-1.487873498) - 1.334570346) \\ &= .670592417. \end{aligned}$$

The Runge-Kutta method is sufficiently accurate for most applications.

**Example 3.3.2** Table 3.3.1 shows results of using the Runge-Kutta method with step sizes  $h = 0.1$  and  $h = 0.05$  to find approximate values of the solution of the initial value problem

$$y' + 2y = x^3 e^{-2x}, \quad y(0) = 1$$

at  $x = 0, 0.1, 0.2, 0.3, \dots, 1.0$ . For comparison, it also shows the corresponding approximate values obtained with the improved Euler method in Example 3.2.2, and the values of the exact solution

$$y = \frac{e^{-2x}}{4}(x^4 + 4).$$

The results obtained by the Runge-Kutta method are clearly better than those obtained by the improved Euler method in fact; the results obtained by the Runge-Kutta method with  $h = 0.1$  are better than those obtained by the improved Euler method with  $h = 0.05$ .

Table 3.3.1. Numerical solution of  $y' + 2y = x^3 e^{-2x}$ ,  $y(0) = 1$ , by the Runge-Kutta method and the improved Euler method.

$x$	$h = 0.1$	$h = 0.05$	$h = 0.1$	$h = 0.05$	Exact
0.0	1.000000000	1.000000000	1.000000000	1.000000000	1.000000000
0.1	0.820040937	0.819050572	0.818753803	0.818751370	0.818751221
0.2	0.672734445	0.671086455	0.670592417	0.670588418	0.670588174
0.3	0.552597643	0.550543878	0.549928221	0.549923281	0.549922980
0.4	0.455160637	0.452890616	0.452210430	0.452205001	0.452204669
0.5	0.376681251	0.374335747	0.373633492	0.373627899	0.373627557
0.6	0.313970920	0.311652239	0.310958768	0.310953242	0.310952904
0.7	0.264287611	0.262067624	0.261404568	0.261399270	0.261398947
0.8	0.225267702	0.223194281	0.222575989	0.222571024	0.222570721
0.9	0.194879501	0.192981757	0.192416882	0.192412317	0.192412038
1.0	0.171388070	0.169680673	0.169173489	0.169169356	0.169169104
	Improved Euler		Runge-Kutta		Exact

**Example 3.3.3** Table 3.3.2 shows analogous results for the nonlinear initial value problem

$$y' = -2y^2 + xy + x^2, \quad y(0) = 1.$$

We applied the improved Euler method to this problem in Example 3.

Table 3.3.2. Numerical solution of  $y' = -2y^2 + xy + x^2$ ,  $y(0) = 1$ , by the Runge-Kutta method and the improved Euler method.

$x$	$h = 0.1$	$h = 0.05$	$h = 0.1$	$h = 0.05$	“Exact”
0.0	1.000000000	1.000000000	1.000000000	1.000000000	1.000000000
0.1	0.840500000	0.838288371	0.837587192	0.837584759	0.837584494
0.2	0.733430846	0.730556677	0.729644487	0.729642155	0.729641890
0.3	0.661600806	0.658552190	0.657582449	0.657580598	0.657580377
0.4	0.615961841	0.612884493	0.611903380	0.611901969	0.611901791
0.5	0.591634742	0.588558952	0.587576716	0.587575635	0.587575491
0.6	0.586006935	0.582927224	0.581943210	0.581942342	0.581942225
0.7	0.597712120	0.594618012	0.593630403	0.593629627	0.593629526
0.8	0.626008824	0.622898279	0.621908378	0.621907553	0.621907458
0.9	0.670351225	0.667237617	0.666251988	0.666250942	0.666250842
1.0	0.730069610	0.726985837	0.726017378	0.726015908	0.726015790
	Improved Euler		Runge-Kutta		“Exact”

**Example 3.3.4** Tables 3.3.3 and 3.3.4 show results obtained by applying the Runge-Kutta and Runge-Kutta semilinear methods to the initial value problem

$$y' - 2xy = 1, \quad y(0) = 3,$$

which we considered in Examples 3.1.4 and 3.2.4.

Table 3.3.3. Numerical solution of  $y' - 2xy = 1$ ,  $y(0) = 3$ , by the Runge-Kutta method.

$x$	$h = 0.2$	$h = 0.1$	$h = 0.05$	“Exact”
0.0	3.000000000	3.000000000	3.000000000	3.000000000
0.2	3.327846400	3.327851633	3.327851952	3.327851973
0.4	3.966044973	3.966058535	3.966059300	3.966059348
0.6	5.066996754	5.067037123	5.067039396	5.067039535
0.8	6.936534178	6.936690679	6.936700320	6.936700945
1.0	10.184232252	10.184877733	10.184920997	10.184923955
1.2	16.064344805	16.066915583	16.067098699	16.067111677
1.4	27.278771833	27.288605217	27.289338955	27.289392347
1.6	49.960553660	49.997313966	50.000165744	50.000377775
1.8	98.834337815	98.971146146	98.982136702	98.982969504
2.0	211.393800152	211.908445283	211.951167637	211.954462214

Table 3.3.4. Numerical solution of  $y' - 2xy = 1$ ,  $y(0) = 3$ , by the Runge-Kutta semilinear method.

$x$	$h = 0.2$	$h = 0.1$	$h = 0.05$	“Exact”
0.0	3.000000000	3.000000000	3.000000000	3.000000000
0.2	3.327853286	3.327852055	3.327851978	3.327851973
0.4	3.966061755	3.966059497	3.966059357	3.966059348
0.6	5.067042602	5.067039725	5.067039547	5.067039535
0.8	6.936704019	6.936701137	6.936700957	6.936700945
1.0	10.184926171	10.184924093	10.184923963	10.184923955
1.2	16.067111961	16.067111696	16.067111678	16.067111677
1.4	27.289389418	27.289392167	27.289392335	27.289392347
1.6	50.000370152	50.000377302	50.000377745	50.000377775
1.8	98.982955511	98.982968633	98.982969450	98.982969504
2.0	211.954439983	211.954460825	211.954462127	211.954462214

### The Case Where $x_0$ Isn't The Left Endpoint

So far in this chapter we've considered numerical methods for solving an initial value problem

$$y' = f(x, y), \quad y(x_0) = y_0 \tag{3.3.3}$$

on an interval  $[x_0, b]$ , for which  $x_0$  is the left endpoint. We haven't discussed numerical methods for solving (3.3.3) on an interval  $[a, x_0]$ , for which  $x_0$  is the right endpoint. To be specific, how can we obtain approximate values  $y_{-1}, y_{-2}, \dots, y_{-n}$  of the solution of (3.3.3) at  $x_0 - h, \dots, x_0 - nh$ , where  $h = (x_0 - a)/n$ ? Here's the answer to this question:

Consider the initial value problem

$$z' = -f(-x, z), \quad z(-x_0) = y_0, \tag{3.3.4}$$

on the interval  $[-x_0, -a]$ , for which  $-x_0$  is the left endpoint. Use a numerical method to obtain approximate values  $z_1, z_2, \dots, z_n$  of the solution of (3.3.4) at  $-x_0 + h, -x_0 + 2h, \dots, -x_0 + nh = -a$ . Then



$y_{-1} = z_1, y_{-2} = z_2, \dots, y_{-n} = z_n$  are approximate values of the solution of (3.3.3) at  $x_0 - h, x_0 - 2h, \dots, x_0 - nh = a$ .

The justification for this answer is sketched in Exercise 23. Note how easy it is to make the change the given problem (3.3.3) to the modified problem (3.3.4): first replace  $f$  by  $-f$  and then replace  $x, x_0$ , and  $y$  by  $-x, -x_0$ , and  $z$ , respectively.

**Example 3.3.5** Use the Runge-Kutta method with step size  $h = 0.1$  to find approximate values of the solution of

$$(y - 1)^2 y' = 2x + 3, \quad y(1) = 4 \quad (3.3.5)$$

at  $x = 0, 0.1, 0.2, \dots, 1$ .

**Solution** We first rewrite (3.3.5) in the form (3.3.3) as

$$y' = \frac{2x + 3}{(y - 1)^2}, \quad y(1) = 4. \quad (3.3.6)$$

Since the initial condition  $y(1) = 4$  is imposed at the right endpoint of the interval  $[0, 1]$ , we apply the Runge-Kutta method to the initial value problem

$$z' = \frac{2x - 3}{(z - 1)^2}, \quad z(-1) = 4 \quad (3.3.7)$$

on the interval  $[-1, 0]$ . (You should verify that (3.3.7) is related to (3.3.6) as (3.3.4) is related to (3.3.3).) Table 3.3.5 shows the results. Reversing the order of the rows in Table 3.3.5 and changing the signs of the values of  $x$  yields the first two columns of Table 3.3.6. The last column of Table 3.3.6 shows the exact values of  $y$ , which are given by

$$y = 1 + (3x^2 + 9x + 15)^{1/3}.$$

(Since the differential equation in (3.3.6) is separable, this formula can be obtained by the method of Section 2.2.)

Table 3.3.5. Numerical solution of  $z' = \frac{2x - 3}{(z - 1)^2}, z(-1) = 4$ , on  $[-1, 0]$ .

$x$	$z$
-1.0	4.000000000
-0.9	3.944536474
-0.8	3.889298649
-0.7	3.834355648
-0.6	3.779786399
-0.5	3.725680888
-0.4	3.672141529
-0.3	3.619284615
-0.2	3.567241862
-0.1	3.516161955
0.0	3.466212070

Table 3.3.6. Numerical solution of  $(y - 1)^2 y' = 2x + 3, y(1) = 4$ , on  $[0, 1]$ .

$x$	$y$	Exact
0.00	3.466212070	3.466212074
0.10	3.516161955	3.516161958
0.20	3.567241862	3.567241864
0.30	3.619284615	3.619284617
0.40	3.672141529	3.672141530
0.50	3.725680888	3.725680889
0.60	3.779786399	3.779786399
0.70	3.834355648	3.834355648
0.80	3.889298649	3.889298649
0.90	3.944536474	3.944536474
1.00	4.000000000	4.000000000

We leave it to you to develop a procedure for handling the numerical solution of (3.3.3) on an interval  $[a, b]$  such that  $a < x_0 < b$  (Exercises 26 and 27).

### 3.3 Exercises

Most of the following numerical exercises involve initial value problems considered in the exercises in Sections 3.2. You'll find it instructive to compare the results that you obtain here with the corresponding results that you obtained in those sections.

In Exercises 1–5 use the Runge-Kutta method to find approximate values of the solution of the given initial value problem at the points  $x_i = x_0 + ih$ , where  $x_0$  is the point where the initial condition is imposed and  $i = 1, 2$ .

- $y' = 2x^2 + 3y^2 - 2$ ,  $y(2) = 1$ ;  $h = 0.05$
- $y' = y + \sqrt{x^2 + y^2}$ ,  $y(0) = 1$ ;  $h = 0.1$
- $y' + 3y = x^2 - 3xy + y^2$ ,  $y(0) = 2$ ;  $h = 0.05$
- $y' = \frac{1+x}{1-y^2}$ ,  $y(2) = 3$ ;  $h = 0.1$
- $y' + x^2y = \sin xy$ ,  $y(1) = \pi$ ;  $h = 0.2$
- Use the Runge-Kutta method with step sizes  $h = 0.1$ ,  $h = 0.05$ , and  $h = 0.025$  to find approximate values of the solution of the initial value problem

$$y' + 3y = 7e^{4x}, \quad y(0) = 2,$$

at  $x = 0, 0.1, 0.2, 0.3, \dots, 1.0$ . Compare these approximate values with the values of the exact solution  $y = e^{4x} + e^{-3x}$ , which can be obtained by the method of Section 2.1. Present your results in a table like Table 3.3.1.

- Use the Runge-Kutta method with step sizes  $h = 0.1$ ,  $h = 0.05$ , and  $h = 0.025$  to find approximate values of the solution of the initial value problem

$$y' + \frac{2}{x}y = \frac{3}{x^3} + 1, \quad y(1) = 1$$

at  $x = 1.0, 1.1, 1.2, 1.3, \dots, 2.0$ . Compare these approximate values with the values of the exact solution

$$y = \frac{1}{3x^2}(9 \ln x + x^3 + 2),$$

which can be obtained by the method of Section 2.1. Present your results in a table like Table 3.3.1.

8. C Use the Runge-Kutta method with step sizes  $h = 0.05$ ,  $h = 0.025$ , and  $h = 0.0125$  to find approximate values of the solution of the initial value problem

$$y' = \frac{y^2 + xy - x^2}{x^2}, \quad y(1) = 2$$

at  $x = 1.0, 1.05, 1.10, 1.15, \dots, 1.5$ . Compare these approximate values with the values of the exact solution

$$y = \frac{x(1 + x^2/3)}{1 - x^2/3},$$

which was obtained in Example 2.2.3. Present your results in a table like Table 3.3.1.

9. C In Example 2.2.3 it was shown that

$$y^5 + y = x^2 + x - 4$$

is an implicit solution of the initial value problem

$$y' = \frac{2x + 1}{5y^4 + 1}, \quad y(2) = 1. \quad (\text{A})$$

Use the Runge-Kutta method with step sizes  $h = 0.1$ ,  $h = 0.05$ , and  $h = 0.025$  to find approximate values of the solution of (A) at  $x = 2.0, 2.1, 2.2, 2.3, \dots, 3.0$ . Present your results in tabular form. To check the error in these approximate values, construct another table of values of the residual

$$R(x, y) = y^5 + y - x^2 - x + 4$$

for each value of  $(x, y)$  appearing in the first table.

10. C You can see from Example 2.5.1 that

$$x^4y^3 + x^2y^5 + 2xy = 4$$

is an implicit solution of the initial value problem

$$y' = -\frac{4x^3y^3 + 2xy^5 + 2y}{3x^4y^2 + 5x^2y^4 + 2x}, \quad y(1) = 1. \quad (\text{A})$$

Use the Runge-Kutta method with step sizes  $h = 0.1$ ,  $h = 0.05$ , and  $h = 0.025$  to find approximate values of the solution of (A) at  $x = 1.0, 1.1, 1.2, 1.3, \dots, 2.0$ . Present your results in tabular form. To check the error in these approximate values, construct another table of values of the residual

$$R(x, y) = x^4y^3 + x^2y^5 + 2xy - 4$$

for each value of  $(x, y)$  appearing in the first table.

11. C Use the Runge-Kutta method with step sizes  $h = 0.1$ ,  $h = 0.05$ , and  $h = 0.025$  to find approximate values of the solution of the initial value problem

$$(3y^2 + 4y)y' + 2x + \cos x = 0, \quad y(0) = 1 \text{ (Exercise 2.2.13),}$$

at  $x = 0, 0.1, 0.2, 0.3, \dots, 1.0$ .

12. **C** Use the Runge-Kutta method with step sizes  $h = 0.1$ ,  $h = 0.05$ , and  $h = 0.025$  to find approximate values of the solution of the initial value problem

$$y' + \frac{(y+1)(y-1)(y-2)}{x+1} = 0, \quad y(1) = 0 \text{ (Exercise 2.2.14),}$$

at  $x = 1.0, 1.1, 1.2, 1.3, \dots, 2.0$ .

13. **C** Use the Runge-Kutta method and the Runge-Kutta semilinear method with step sizes  $h = 0.1$ ,  $h = 0.05$ , and  $h = 0.025$  to find approximate values of the solution of the initial value problem

$$y' + 3y = e^{-3x}(1 - 4x + 3x^2 - 4x^3), \quad y(0) = -3$$

at  $x = 0, 0.1, 0.2, 0.3, \dots, 1.0$ . Compare these approximate values with the values of the exact solution  $y = -e^{-3x}(3 - x + 2x^2 - x^3 + x^4)$ , which can be obtained by the method of Section 2.1. Do you notice anything special about the results? Explain.

The linear initial value problems in Exercises 14–19 can't be solved exactly in terms of known elementary functions. In each exercise use the Runge-Kutta and the Runge-Kutta semilinear methods with the indicated step sizes to find approximate values of the solution of the given initial value problem at 11 equally spaced points (including the endpoints) in the interval.

14. **C**  $y' - 2y = \frac{1}{1+x^2}$ ,  $y(2) = 2$ ;  $h = 0.1, 0.05, 0.025$  on  $[2, 3]$
15. **C**  $y' + 2xy = x^2$ ,  $y(0) = 3$ ;  $h = 0.2, 0.1, 0.05$  on  $[0, 2]$  (Exercise 2.1.38)
16. **C**  $y' + \frac{1}{x}y = \frac{\sin x}{x^2}$ ,  $y(1) = 2$ ;  $h = 0.2, 0.1, 0.05$  on  $[1, 3]$  (Exercise 2.1.39)
17. **C**  $y' + y = \frac{e^{-x} \tan x}{x}$ ,  $y(1) = 0$ ;  $h = 0.05, 0.025, 0.0125$  on  $[1, 1.5]$  (Exercise 2.1.40)
18. **C**  $y' + \frac{2x}{1+x^2}y = \frac{e^x}{(1+x^2)^2}$ ,  $y(0) = 1$ ;  $h = 0.2, 0.1, 0.05$  on  $[0, 2]$  (Exercise 2.1.41)
19. **C**  $xy' + (x+1)y = e^{x^2}$ ,  $y(1) = 2$ ;  $h = 0.05, 0.025, 0.0125$  on  $[1, 1.5]$  (Exercise 2.1.42)

In Exercises 20–22 use the Runge-Kutta method and the Runge-Kutta semilinear method with the indicated step sizes to find approximate values of the solution of the given initial value problem at 11 equally spaced points (including the endpoints) in the interval.

20. **C**  $y' + 3y = xy^2(y+1)$ ,  $y(0) = 1$ ;  $h = 0.1, 0.05, 0.025$  on  $[0, 1]$
21. **C**  $y' - 4y = \frac{x}{y^2(y+1)}$ ,  $y(0) = 1$ ;  $h = 0.1, 0.05, 0.025$  on  $[0, 1]$
22. **C**  $y' + 2y = \frac{x^2}{1+y^2}$ ,  $y(2) = 1$ ;  $h = 0.1, 0.05, 0.025$  on  $[2, 3]$

23. **C** Suppose  $a < x_0$ , so that  $-x_0 < -a$ . Use the chain rule to show that if  $z$  is a solution of

$$z' = -f(-x, z), \quad z(-x_0) = y_0,$$

on  $[-x_0, -a]$ , then  $y = z(-x)$  is a solution of

$$y' = f(x, y), \quad y(x_0) = y_0,$$

on  $[a, x_0]$ .

24. **C** Use the Runge-Kutta method with step sizes  $h = 0.1$ ,  $h = 0.05$ , and  $h = 0.025$  to find approximate values of the solution of

$$y' = \frac{y^2 + xy - x^2}{x^2}, \quad y(2) = -1$$

at  $x = 1.1, 1.2, 1.3, \dots, 2.0$ . Compare these approximate values with the values of the exact solution

$$y = \frac{x(4 - 3x^2)}{4 + 3x^2},$$

which can be obtained by referring to Example 2.4.3.

25. **C** Use the Runge-Kutta method with step sizes  $h = 0.1$ ,  $h = 0.05$ , and  $h = 0.025$  to find approximate values of the solution of

$$y' = -x^2y - xy^2, \quad y(1) = 1$$

at  $x = 0, 0.1, 0.2, \dots, 1$ .

26. **C** Use the Runge-Kutta method with step sizes  $h = 0.1$ ,  $h = 0.05$ , and  $h = 0.025$  to find approximate values of the solution of

$$y' + \frac{1}{x}y = \frac{7}{x^2} + 3, \quad y(1) = \frac{3}{2}$$

at  $x = 0.5, 0.6, \dots, 1.5$ . Compare these approximate values with the values of the exact solution

$$y = \frac{7 \ln x}{x} + \frac{3x}{2},$$

which can be obtained by the method discussed in Section 2.1.

27. **C** Use the Runge-Kutta method with step sizes  $h = 0.1$ ,  $h = 0.05$ , and  $h = 0.025$  to find approximate values of the solution of

$$xy' + 2y = 8x^2, \quad y(2) = 5$$

at  $x = 1.0, 1.1, 1.2, \dots, 3.0$ . Compare these approximate values with the values of the exact solution

$$y = 2x^2 - \frac{12}{x^2},$$

which can be obtained by the method discussed in Section 2.1.

28. NUMERICAL QUADRATURE (see Exercise 3.1.23).

(a) Derive the quadrature formula

$$\int_a^b f(x) dx \approx \frac{h}{6}(f(a) + f(b)) + \frac{h}{3} \sum_{i=1}^{n-1} f(a + ih) + \frac{2h}{3} \sum_{i=1}^n f(a + (2i - 1)h/2) \quad (\text{A})$$

(where  $h = (b - a)/n$ ) by applying the Runge-Kutta method to the initial value problem

$$y' = f(x), \quad y(a) = 0.$$

This quadrature formula is called *Simpson's Rule*.

- (b) **L** For several choices of  $a, b, A, B, C,$  and  $D$  apply (A) to  $f(x) = A + Bx + Cx + Dx^3$ , with  $n = 10, 20, 40, 80, 160, 320$ . Compare your results with the exact answers and explain what you find.
- (c) **L** For several choices of  $a, b, A, B, C, D,$  and  $E$  apply (A) to  $f(x) = A + Bx + Cx^2 + Dx^3 + Ex^4$ , with  $n = 10, 20, 40, 80, 160, 320$ . Compare your results with the exact answers and explain what you find.

# CHAPTER 4

## Applications of First Order Equations

IN THIS CHAPTER we consider applications of first order differential equations.

SECTION 4.1 begins with a discussion of exponential growth and decay, which you have probably already seen in calculus. We consider applications to radioactive decay, carbon dating, and compound interest. We also consider more complicated problems where the rate of change of a quantity is in part proportional to the magnitude of the quantity, but is also influenced by other other factors for example, a radioactive substance is manufactured at a certain rate, but decays at a rate proportional to its mass, or a saver makes regular deposits in a savings account that draws compound interest.

SECTION 4.2 deals with applications of Newton's law of cooling and with mixing problems.

SECTION 4.3 discusses applications to elementary mechanics involving Newton's second law of motion. The problems considered include motion under the influence of gravity in a resistive medium, and determining the initial velocity required to launch a satellite.

SECTION 4.4 deals with methods for dealing with a type of second order equation that often arises in applications of Newton's second law of motion, by reformulating it as first order equation with a different independent variable. Although the method doesn't usually lead to an explicit solution of the given equation, it does provide valuable insights into the behavior of the solutions.

SECTION 4.5 deals with applications of differential equations to curves.

### 4.1 GROWTH AND DECAY

Since the applications in this section deal with functions of time, we'll denote the independent variable by  $t$ . If  $Q$  is a function of  $t$ ,  $Q'$  will denote the derivative of  $Q$  with respect to  $t$ ; thus,

$$Q' = \frac{dQ}{dt}.$$

#### Exponential Growth and Decay

One of the most common mathematical models for a physical process is the *exponential model*, where it's assumed that the rate of change of a quantity  $Q$  is proportional to  $Q$ ; thus

$$Q' = aQ, \quad (4.1.1)$$

where  $a$  is the constant of proportionality.

From Example 3, the general solution of (4.1.1) is

$$Q = ce^{at}$$

and the solution of the initial value problem

$$Q' = aQ, \quad Q(t_0) = Q_0$$

is

$$Q = Q_0 e^{a(t-t_0)}. \quad (4.1.2)$$

Since the solutions of  $Q' = aQ$  are exponential functions, we say that a quantity  $Q$  that satisfies this equation *grows exponentially* if  $a > 0$ , or *decays exponentially* if  $a < 0$  (Figure 4.1.1).

#### Radioactive Decay

Experimental evidence shows that radioactive material decays at a rate proportional to the mass of the material present. According to this model the mass  $Q(t)$  of a radioactive material present at time  $t$  satisfies (4.1.1), where  $a$  is a negative constant whose value for any given material must be determined by experimental observation. For simplicity, we'll replace the negative constant  $a$  by  $-k$ , where  $k$  is a positive number that we'll call the *decay constant* of the material. Thus, (4.1.1) becomes

$$Q' = -kQ.$$

If the mass of the material present at  $t = t_0$  is  $Q_0$ , the mass present at time  $t$  is the solution of

$$Q' = -kQ, \quad Q(t_0) = Q_0.$$

From (4.1.2) with  $a = -k$ , the solution of this initial value problem is

$$Q = Q_0 e^{-k(t-t_0)}. \quad (4.1.3)$$

The *half-life*  $\tau$  of a radioactive material is defined to be the time required for half of its mass to decay; that is, if  $Q(t_0) = Q_0$ , then

$$Q(\tau + t_0) = \frac{Q_0}{2}. \quad (4.1.4)$$

From (4.1.3) with  $t = \tau + t_0$ , (4.1.4) is equivalent to

$$Q_0 e^{-k\tau} = \frac{Q_0}{2},$$



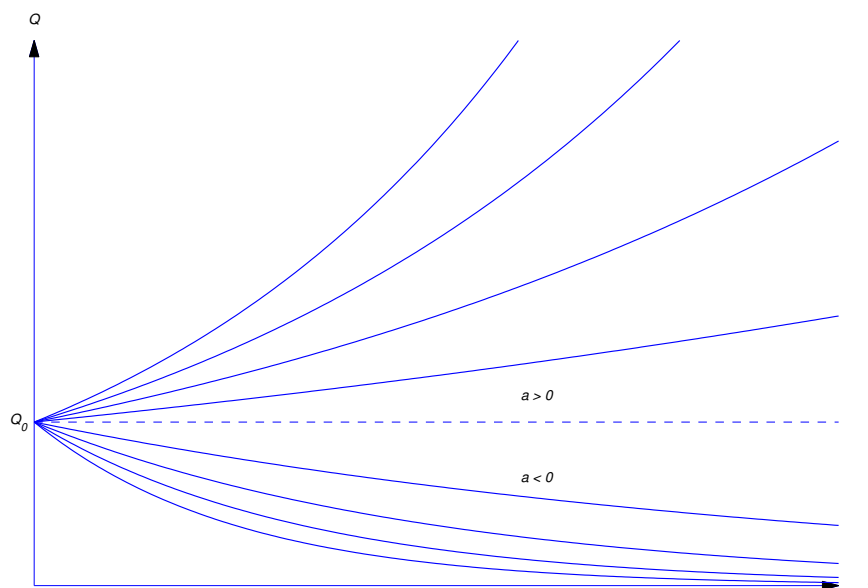

Figure 4.1.1 Exponential growth and decay

so

$$e^{-k\tau} = \frac{1}{2}.$$

Taking logarithms yields

$$-k\tau = \ln \frac{1}{2} = -\ln 2,$$

so the half-life is

$$\tau = \frac{1}{k} \ln 2. \quad (4.1.5)$$

(Figure 4.1.2). The half-life is independent of  $t_0$  and  $Q_0$ , since it's determined by the properties of material, not by the amount of the material present at any particular time.

**Example 4.1.1** A radioactive substance has a half-life of 1620 years.

- (a) If its mass is now 4 g (grams), how much will be left 810 years from now?  
 (b) Find the time  $t_1$  when 1.5 g of the substance remain.

**SOLUTION(a)** From (4.1.3) with  $t_0 = 0$  and  $Q_0 = 4$ ,

$$Q = 4e^{-kt}, \quad (4.1.6)$$

where we determine  $k$  from (4.1.5), with  $\tau = 1620$  years:

$$k = \frac{\ln 2}{\tau} = \frac{\ln 2}{1620}.$$

Substituting this in (4.1.6) yields

$$Q = 4e^{-(t \ln 2)/1620}. \quad (4.1.7)$$

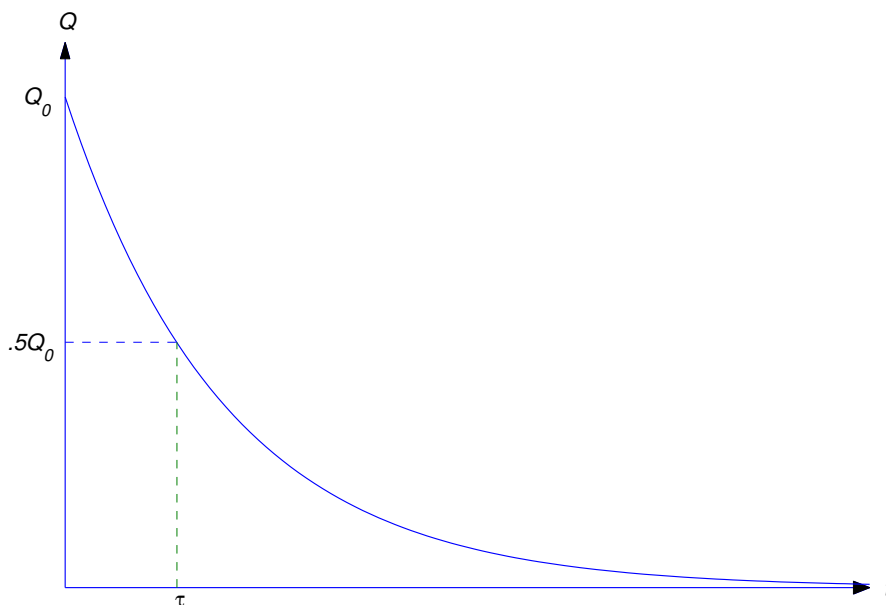

Figure 4.1.2 Half-life of a radioactive substance

Therefore the mass left after 810 years will be

$$\begin{aligned} Q(810) &= 4e^{-(810 \ln 2)/1620} = 4e^{-(\ln 2)/2} \\ &= 2\sqrt{2} \text{ g.} \end{aligned}$$

**SOLUTION(b)** Setting  $t = t_1$  in (4.1.7) and requiring that  $Q(t_1) = 1.5$  yields

$$\frac{3}{2} = 4e^{(-t_1 \ln 2)/1620}.$$

Dividing by 4 and taking logarithms yields

$$\ln \frac{3}{8} = -\frac{t_1 \ln 2}{1620}.$$

Since  $\ln 3/8 = -\ln 8/3$ ,

$$t_1 = 1620 \frac{\ln 8/3}{\ln 2} \approx 2292.4 \text{ years.}$$

### Interest Compounded Continuously

Suppose we deposit an amount of money  $Q_0$  in an interest-bearing account and make no further deposits or withdrawals for  $t$  years, during which the account bears interest at a constant annual rate  $r$ . To calculate the value of the account at the end of  $t$  years, we need one more piece of information: how the interest is added to the account, or—as the bankers say—how it is *compounded*. If the interest is compounded annually, the value of the account is multiplied by  $1 + r$  at the end of each year. This means that after  $t$  years the value of the account is

$$Q(t) = Q_0(1 + r)^t.$$

If interest is compounded semiannually, the value of the account is multiplied by  $(1 + r/2)$  every 6 months. Since this occurs twice annually, the value of the account after  $t$  years is

$$Q(t) = Q_0 \left(1 + \frac{r}{2}\right)^{2t}.$$

In general, if interest is compounded  $n$  times per year, the value of the account is multiplied  $n$  times per year by  $(1 + r/n)$ ; therefore, the value of the account after  $t$  years is

$$Q(t) = Q_0 \left(1 + \frac{r}{n}\right)^{nt}. \quad (4.1.8)$$

Thus, increasing the frequency of compounding increases the value of the account after a fixed period of time. Table 4.1.7 shows the effect of increasing the number of compoundings over  $t = 5$  years on an initial deposit of  $Q_0 = 100$  (dollars), at an annual interest rate of 6%.

Table 4.1.7. Table The effect of compound interest

$n$ (number of compoundings per year)	$\$100 \left(1 + \frac{.06}{n}\right)^{5n}$ (value in dollars after 5 years)
1	\$133.82
2	\$134.39
4	\$134.68
8	\$134.83
364	\$134.98

You can see from Table 4.1.7 that the value of the account after 5 years is an increasing function of  $n$ . Now suppose the maximum allowable rate of interest on savings accounts is restricted by law, but the time intervals between successive compoundings isn't; then competing banks can attract savers by compounding often. The ultimate step in this direction is to *compound continuously*, by which we mean that  $n \rightarrow \infty$  in (4.1.8). Since we know from calculus that

$$\lim_{n \rightarrow \infty} \left(1 + \frac{r}{n}\right)^n = e^r,$$

this yields

$$\begin{aligned} Q(t) &= \lim_{n \rightarrow \infty} Q_0 \left(1 + \frac{r}{n}\right)^{nt} = Q_0 \left[ \lim_{n \rightarrow \infty} \left(1 + \frac{r}{n}\right)^n \right]^t \\ &= Q_0 e^{rt}. \end{aligned}$$

Observe that  $Q = Q_0 e^{rt}$  is the solution of the initial value problem

$$Q' = rQ, \quad Q(0) = Q_0;$$

that is, with continuous compounding the value of the account grows exponentially.

**Example 4.1.2** If \$150 is deposited in a bank that pays  $5\frac{1}{2}\%$  annual interest compounded continuously, the value of the account after  $t$  years is

$$Q(t) = 150e^{.055t}$$

dollars. (Note that it's necessary to write the interest rate as a decimal; thus,  $r = .055$ .) Therefore, after  $t = 10$  years the value of the account is

$$Q(10) = 150e^{.55} \approx \$259.99.$$

**Example 4.1.3** We wish to accumulate \$10,000 in 10 years by making a single deposit in a savings account bearing  $5\frac{1}{2}\%$  annual interest compounded continuously. How much must we deposit in the account?

**Solution** The value of the account at time  $t$  is

$$Q(t) = Q_0e^{.055t}. \quad (4.1.9)$$

Since we want  $Q(10)$  to be \$10,000, the initial deposit  $Q_0$  must satisfy the equation

$$10000 = Q_0e^{.55}, \quad (4.1.10)$$

obtained by setting  $t = 10$  and  $Q(10) = 10000$  in (4.1.9). Solving (4.1.10) for  $Q_0$  yields

$$Q_0 = 10000e^{-.55} \approx \$5769.50.$$

### Mixed Growth and Decay

**Example 4.1.4** A radioactive substance with decay constant  $k$  is produced at a constant rate of  $a$  units of mass per unit time.

- (a) Assuming that  $Q(0) = Q_0$ , find the mass  $Q(t)$  of the substance present at time  $t$ .  
 (b) Find  $\lim_{t \rightarrow \infty} Q(t)$ .

**SOLUTION(a)** Here

$$Q' = \text{rate of increase of } Q - \text{rate of decrease of } Q.$$

The rate of increase is the constant  $a$ . Since  $Q$  is radioactive with decay constant  $k$ , the rate of decrease is  $kQ$ . Therefore

$$Q' = a - kQ.$$

This is a linear first order differential equation. Rewriting it and imposing the initial condition shows that  $Q$  is the solution of the initial value problem

$$Q' + kQ = a, \quad Q(0) = Q_0. \quad (4.1.11)$$

Since  $e^{-kt}$  is a solution of the complementary equation, the solutions of (4.1.11) are of the form  $Q = ue^{-kt}$ , where  $u'e^{-kt} = a$ , so  $u' = ae^{kt}$ . Hence,

$$u = \frac{a}{k}e^{kt} + c$$

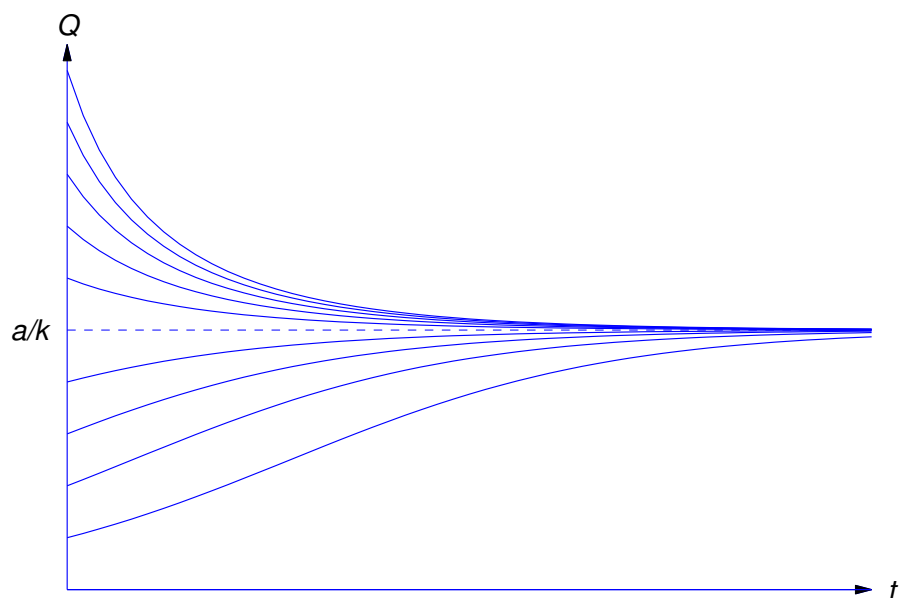

Figure 4.1.3  $Q(t)$  approaches the steady state value  $\frac{a}{k}$  as  $t \rightarrow \infty$

and

$$Q = ue^{-kt} = \frac{a}{k} + ce^{-kt}.$$

Since  $Q(0) = Q_0$ , setting  $t = 0$  here yields

$$Q_0 = \frac{a}{k} + c \quad \text{or} \quad c = Q_0 - \frac{a}{k}.$$

Therefore

$$Q = \frac{a}{k} + \left(Q_0 - \frac{a}{k}\right)e^{-kt}. \quad (4.1.12)$$

**SOLUTION(b)** Since  $k > 0$ ,  $\lim_{t \rightarrow \infty} e^{-kt} = 0$ , so from (4.1.12)

$$\lim_{t \rightarrow \infty} Q(t) = \frac{a}{k}.$$

This limit depends only on  $a$  and  $k$ , and not on  $Q_0$ . We say that  $a/k$  is the *steady state* value of  $Q$ . From (4.1.12) we also see that  $Q$  approaches its steady state value from above if  $Q_0 > a/k$ , or from below if  $Q_0 < a/k$ . If  $Q_0 = a/k$ , then  $Q$  remains constant (Figure 4.1.3).

### Carbon Dating

The fact that  $Q$  approaches a steady state value in the situation discussed in Example 4 underlies the method of *carbon dating*, devised by the American chemist and Nobel Prize Winner *W.S. Libby*.

Carbon 12 is stable, but carbon-14, which is produced by cosmic bombardment of nitrogen in the upper atmosphere, is radioactive with a half-life of about 5570 years. Libby assumed that the quantity of carbon-12 in the atmosphere has been constant throughout time, and that the quantity of radioactive carbon-14

achieved its steady state value long ago as a result of its creation and decomposition over millions of years. These assumptions led Libby to conclude that the ratio of carbon-14 to carbon-12 has been nearly constant for a long time. This constant, which we denote by  $R$ , has been determined experimentally.

Living cells absorb both carbon-12 and carbon-14 in the proportion in which they are present in the environment. Therefore the ratio of carbon-14 to carbon-12 in a living cell is always  $R$ . However, when the cell dies it ceases to absorb carbon, and the ratio of carbon-14 to carbon-12 decreases exponentially as the radioactive carbon-14 decays. This is the basis for the method of carbon dating, as illustrated in the next example.

**Example 4.1.5** An archaeologist investigating the site of an ancient village finds a burial ground where the amount of carbon-14 present in individual remains is between 42 and 44% of the amount present in live individuals. Estimate the age of the village and the length of time for which it survived.

**Solution** Let  $Q = Q(t)$  be the quantity of carbon-14 in an individual set of remains  $t$  years after death, and let  $Q_0$  be the quantity that would be present in live individuals. Since carbon-14 decays exponentially with half-life 5570 years, its decay constant is

$$k = \frac{\ln 2}{5570}.$$

Therefore

$$Q = Q_0 e^{-t(\ln 2)/5570}$$

if we choose our time scale so that  $t_0 = 0$  is the time of death. If we know the present value of  $Q$  we can solve this equation for  $t$ , the number of years since death occurred. This yields

$$t = -5570 \frac{\ln Q/Q_0}{\ln 2}.$$

It is given that  $Q = .42Q_0$  in the remains of individuals who died first. Therefore these deaths occurred about

$$t_1 = -5570 \frac{\ln .42}{\ln 2} \approx 6971$$

years ago. For the most recent deaths,  $Q = .44Q_0$ ; hence, these deaths occurred about

$$t_2 = -5570 \frac{\ln .44}{\ln 2} \approx 6597$$

years ago. Therefore it's reasonable to conclude that the village was founded about 7000 years ago, and lasted for about 400 years.

### A Savings Program

**Example 4.1.6** A person opens a savings account with an initial deposit of \$1000 and subsequently deposits \$50 per week. Find the value  $Q(t)$  of the account at time  $t > 0$ , assuming that the bank pays 6% interest compounded continuously.

**Solution** Observe that  $Q$  isn't continuous, since there are 52 discrete deposits per year of \$50 each. To construct a mathematical model for this problem in the form of a differential equation, we make the simplifying assumption that the deposits are made continuously at a rate of \$2600 per year. This is essential, since solutions of differential equations are continuous functions. With this assumption,  $Q$  increases continuously at the rate

$$Q' = 2600 + .06Q$$

and therefore  $Q$  satisfies the differential equation

$$Q' - .06Q = 2600. \quad (4.1.13)$$

(Of course, we must recognize that the solution of this equation is an approximation to the true value of  $Q$  at any given time. We'll discuss this further below.) Since  $e^{.06t}$  is a solution of the complementary equation, the solutions of (4.1.13) are of the form  $Q = ue^{.06t}$ , where  $u'e^{.06t} = 2600$ . Hence,  $u' = 2600e^{-.06t}$ ,

$$u = -\frac{2600}{.06}e^{-.06t} + c$$

and

$$Q = ue^{.06t} = -\frac{2600}{.06} + ce^{.06t}. \quad (4.1.14)$$

Setting  $t = 0$  and  $Q = 1000$  here yields

$$c = 1000 + \frac{2600}{.06},$$

and substituting this into (4.1.14) yields

$$Q = 1000e^{.06t} + \frac{2600}{.06}(e^{.06t} - 1), \quad (4.1.15)$$

where the first term is the value due to the initial deposit and the second is due to the subsequent weekly deposits. ■

Mathematical models must be tested for validity by comparing predictions based on them with the actual outcome of experiments. Example 6 is unusual in that we can compute the exact value of the account at any specified time and compare it with the approximate value predicted by (4.1.15) (See Exercise 21.). The following table gives a comparison for a ten year period. Each exact answer corresponds to the time of the year-end deposit, and each year is assumed to have exactly 52 weeks.

Year	Approximate Value of $Q$ (Example 4.1.6)	Exact Value of $P$ (Exercise 21)	Error $Q - P$	Percentage Error $(Q - P)/P$
1	\$ 3741.42	\$ 3739.87	\$ 1.55	.0413%
2	6652.36	6649.17	3.19	.0479
3	9743.30	9738.37	4.93	.0506
4	13,025.38	13,018.60	6.78	.0521
5	16,510.41	16,501.66	8.75	.0530
6	20,210.94	20,200.11	10.83	.0536
7	24,140.30	24,127.25	13.05	.0541
8	28,312.63	28,297.23	15.40	.0544
9	32,742.97	32,725.07	17.90	.0547
10	37,447.27	37,426.72	20.55	.0549

### 4.1 Exercises

---

1. The half-life of a radioactive substance is 3200 years. Find the quantity  $Q(t)$  of the substance left at time  $t > 0$  if  $Q(0) = 20$  g.
2. The half-life of a radioactive substance is 2 days. Find the time required for a given amount of the material to decay to  $1/10$  of its original mass.
3. A radioactive material loses 25% of its mass in 10 minutes. What is its half-life?
4. A tree contains a known percentage  $p_0$  of a radioactive substance with half-life  $\tau$ . When the tree dies the substance decays and isn't replaced. If the percentage of the substance in the fossilized remains of such a tree is found to be  $p_1$ , how long has the tree been dead?
5. If  $t_p$  and  $t_q$  are the times required for a radioactive material to decay to  $1/p$  and  $1/q$  times its original mass (respectively), how are  $t_p$  and  $t_q$  related?
6. Find the decay constant  $k$  for a radioactive substance, given that the mass of the substance is  $Q_1$  at time  $t_1$  and  $Q_2$  at time  $t_2$ .
7. A process creates a radioactive substance at the rate of 2 g/hr and the substance decays at a rate proportional to its mass, with constant of proportionality  $k = .1(\text{hr})^{-1}$ . If  $Q(t)$  is the mass of the substance at time  $t$ , find  $\lim_{t \rightarrow \infty} Q(t)$ .
8. A bank pays interest continuously at the rate of 6%. How long does it take for a deposit of  $Q_0$  to grow in value to  $2Q_0$ ?
9. At what rate of interest, compounded continuously, will a bank deposit double in value in 8 years?
10. A savings account pays 5% per annum interest compounded continuously. The initial deposit is  $Q_0$  dollars. Assume that there are no subsequent withdrawals or deposits.
  - (a) How long will it take for the value of the account to triple?
  - (b) What is  $Q_0$  if the value of the account after 10 years is \$100,000 dollars?
11. A candymaker makes 500 pounds of candy per week, while his large family eats the candy at a rate equal to  $Q(t)/10$  pounds per week, where  $Q(t)$  is the amount of candy present at time  $t$ .
  - (a) Find  $Q(t)$  for  $t > 0$  if the candymaker has 250 pounds of candy at  $t = 0$ .
  - (b) Find  $\lim_{t \rightarrow \infty} Q(t)$ .
12. Suppose a substance decays at a yearly rate equal to half the square of the mass of the substance present. If we start with 50 g of the substance, how long will it be until only 25 g remain?
13. A super bread dough increases in volume at a rate proportional to the volume  $V$  present. If  $V$  increases by a factor of 10 in 2 hours and  $V(0) = V_0$ , find  $V$  at any time  $t$ . How long will it take for  $V$  to increase to  $100V_0$ ?
14. A radioactive substance decays at a rate proportional to the amount present, and half the original quantity  $Q_0$  is left after 1500 years. In how many years would the original amount be reduced to  $3Q_0/4$ ? How much will be left after 2000 years?
15. A wizard creates gold continuously at the rate of 1 ounce per hour, but an assistant steals it continuously at the rate of 5% of however much is there per hour. Let  $W(t)$  be the number of ounces that the wizard has at time  $t$ . Find  $W(t)$  and  $\lim_{t \rightarrow \infty} W(t)$  if  $W(0) = 1$ .
16. A process creates a radioactive substance at the rate of 1 g/hr, and the substance decays at an hourly rate equal to  $1/10$  of the mass present (expressed in grams). Assuming that there are initially 20 g, find the mass  $S(t)$  of the substance present at time  $t$ , and find  $\lim_{t \rightarrow \infty} S(t)$ .



17. A tank is empty at  $t = 0$ . Water is added to the tank at the rate of 10 gal/min, but it leaks out at a rate (in gallons per minute) equal to the number of gallons in the tank. What is the smallest capacity the tank can have if this process is to continue forever?
18. A person deposits \$25,000 in a bank that pays 5% per year interest, compounded continuously. The person continuously withdraws from the account at the rate of \$750 per year. Find  $V(t)$ , the value of the account at time  $t$  after the initial deposit.
19. A person has a fortune that grows at rate proportional to the square root of its worth. Find the worth  $W$  of the fortune as a function of  $t$  if it was \$1 million 6 months ago and is \$4 million today.
20. Let  $p = p(t)$  be the quantity of a product present at time  $t$ . The product is manufactured continuously at a rate proportional to  $p$ , with proportionality constant  $1/2$ , and it's consumed continuously at a rate proportional to  $p^2$ , with proportionality constant  $1/8$ . Find  $p(t)$  if  $p(0) = 100$ .
21. (a) In the situation of Example 4.1.6 find the exact value  $P(t)$  of the person's account after  $t$  years, where  $t$  is an integer. Assume that each year has exactly 52 weeks, and include the year-end deposit in the computation.

HINT: At time  $t$  the initial \$1000 has been on deposit for  $t$  years. There have been  $52t$  deposits of \$50 each. The first \$50 has been on deposit for  $t - 1/52$  years, the second for  $t - 2/52$  years  $\cdots$  in general, the  $j$ th \$50 has been on deposit for  $t - j/52$  years ( $1 \leq j \leq 52t$ ). Find the present value of each \$50 deposit assuming 6% interest compounded continuously, and use the formula

$$1 + x + x^2 + \cdots + x^n = \frac{1 - x^{n+1}}{1 - x} \quad (x \neq 1)$$

to find their total value.

- (b) Let

$$p(t) = \frac{Q(t) - P(t)}{P(t)}$$

be the relative error after  $t$  years. Find

$$p(\infty) = \lim_{t \rightarrow \infty} p(t).$$

22. A homebuyer borrows  $P_0$  dollars at an annual interest rate  $r$ , agreeing to repay the loan with equal monthly payments of  $M$  dollars per month over  $N$  years.
- (a) Derive a differential equation for the loan principal (amount that the homebuyer owes)  $P(t)$  at time  $t > 0$ , making the simplifying assumption that the homebuyer repays the loan continuously rather than in discrete steps. (See Example 4.1.6.)
- (b) Solve the equation derived in (a).
- (c) Use the result of (b) to determine an approximate value for  $M$  assuming that each year has exactly 12 months of equal length.
- (d) It can be shown that the exact value of  $M$  is given by

$$M = \frac{rP_0}{12} (1 - (1 + r/12)^{-12N})^{-1}.$$

Compare the value of  $M$  obtained from the answer in (c) to the exact value if (i)  $P_0 = \$50,000$ ,  $r = 7\frac{1}{2}\%$ ,  $N = 20$  (ii)  $P_0 = \$150,000$ ,  $r = 9.0\%$ ,  $N = 30$ .

23. Assume that the homebuyer of Exercise 22 elects to repay the loan continuously at the rate of  $\alpha M$  dollars per month, where  $\alpha$  is a constant greater than 1. (This is called *accelerated payment*.)

- (a) Determine the time  $T(\alpha)$  when the loan will be paid off and the amount  $S(\alpha)$  that the home-buyer will save.
- (b) Suppose  $P_0 = \$50,000$ ,  $r = 8\%$ , and  $N = 15$ . Compute the savings realized by accelerated payments with  $\alpha = 1.05, 1.10$ , and  $1.15$ .
24. A benefactor wishes to establish a trust fund to pay a researcher's salary for  $T$  years. The salary is to start at  $S_0$  dollars per year and increase at a fractional rate of  $a$  per year. Find the amount of money  $P_0$  that the benefactor must deposit in a trust fund paying interest at a rate  $r$  per year. Assume that the researcher's salary is paid continuously, the interest is compounded continuously, and the salary increases are granted continuously.
25. **L** A radioactive substance with decay constant  $k$  is produced at the rate of

$$\frac{at}{1 + btQ(t)}$$

units of mass per unit time, where  $a$  and  $b$  are positive constants and  $Q(t)$  is the mass of the substance present at time  $t$ ; thus, the rate of production is small at the start and tends to slow when  $Q$  is large.

- (a) Set up a differential equation for  $Q$ .
- (b) Choose your own positive values for  $a$ ,  $b$ ,  $k$ , and  $Q_0 = Q(0)$ . Use a numerical method to discover what happens to  $Q(t)$  as  $t \rightarrow \infty$ . (Be precise, expressing your conclusions in terms of  $a$ ,  $b$ ,  $k$ . However, no proof is required.)
26. **L** Follow the instructions of Exercise 25, assuming that the substance is produced at the rate of  $at/(1 + bt(Q(t))^2)$  units of mass per unit of time.
27. **L** Follow the instructions of Exercise 25, assuming that the substance is produced at the rate of  $at/(1 + bt)$  units of mass per unit of time.

## 4.2 COOLING AND MIXING

### Newton's Law of Cooling

Newton's law of cooling states that if an object with temperature  $T(t)$  at time  $t$  is in a medium with temperature  $T_m(t)$ , the rate of change of  $T$  at time  $t$  is proportional to  $T(t) - T_m(t)$ ; thus,  $T$  satisfies a differential equation of the form

$$T' = -k(T - T_m). \quad (4.2.1)$$

Here  $k > 0$ , since the temperature of the object must decrease if  $T > T_m$ , or increase if  $T < T_m$ . We'll call  $k$  the *temperature decay constant of the medium*.

For simplicity, in this section we'll assume that the medium is maintained at a constant temperature  $T_m$ . This is another example of building a simple mathematical model for a physical phenomenon. Like most mathematical models it has its limitations. For example, it's reasonable to assume that the temperature of a room remains approximately constant if the cooling object is a cup of coffee, but perhaps not if it's a huge cauldron of molten metal. (For more on this see Exercise 17.)

To solve (4.2.1), we rewrite it as

$$T' + kT = kT_m.$$

Since  $e^{-kt}$  is a solution of the complementary equation, the solutions of this equation are of the form  $T = ue^{-kt}$ , where  $u'e^{-kt} = kT_m$ , so  $u' = kT_me^{kt}$ . Hence,

$$u = T_me^{kt} + c,$$

so

$$T = ue^{-kt} = T_m + ce^{-kt}.$$

If  $T(0) = T_0$ , setting  $t = 0$  here yields  $c = T_0 - T_m$ , so

$$T = T_m + (T_0 - T_m)e^{-kt}. \quad (4.2.2)$$

Note that  $T - T_m$  decays exponentially, with decay constant  $k$ .

**Example 4.2.1** A ceramic insulator is baked at  $400^\circ\text{C}$  and cooled in a room in which the temperature is  $25^\circ\text{C}$ . After 4 minutes the temperature of the insulator is  $200^\circ\text{C}$ . What is its temperature after 8 minutes?

**Solution** Here  $T_0 = 400$  and  $T_m = 25$ , so (4.2.2) becomes

$$T = 25 + 375e^{-kt}. \quad (4.2.3)$$

We determine  $k$  from the stated condition that  $T(4) = 200$ ; that is,

$$200 = 25 + 375e^{-4k};$$

hence,

$$e^{-4k} = \frac{175}{375} = \frac{7}{15}.$$

Taking logarithms and solving for  $k$  yields

$$k = -\frac{1}{4} \ln \frac{7}{15} = \frac{1}{4} \ln \frac{15}{7}.$$

Substituting this into (4.2.3) yields

$$T = 25 + 375e^{-\frac{1}{4} \ln \frac{15}{7}}$$

(Figure 4.2.1). Therefore the temperature of the insulator after 8 minutes is

$$\begin{aligned} T(8) &= 25 + 375e^{-2 \ln \frac{15}{7}} \\ &= 25 + 375 \left( \frac{7}{15} \right)^2 \approx 107^\circ\text{C}. \end{aligned}$$

**Example 4.2.2** An object with temperature  $72^\circ\text{F}$  is placed outside, where the temperature is  $-20^\circ\text{F}$ . At 11:05 the temperature of the object is  $60^\circ\text{F}$  and at 11:07 its temperature is  $50^\circ\text{F}$ . At what time was the object placed outside?

**Solution** Let  $T(t)$  be the temperature of the object at time  $t$ . For convenience, we choose the origin  $t_0 = 0$  of the time scale to be 11:05 so that  $T_0 = 60$ . We must determine the time  $\tau$  when  $T(\tau) = 72$ . Substituting  $T_0 = 60$  and  $T_m = -20$  into (4.2.2) yields

$$T = -20 + (60 - (-20))e^{-kt}$$

or

$$T = -20 + 80e^{-kt}. \quad (4.2.4)$$

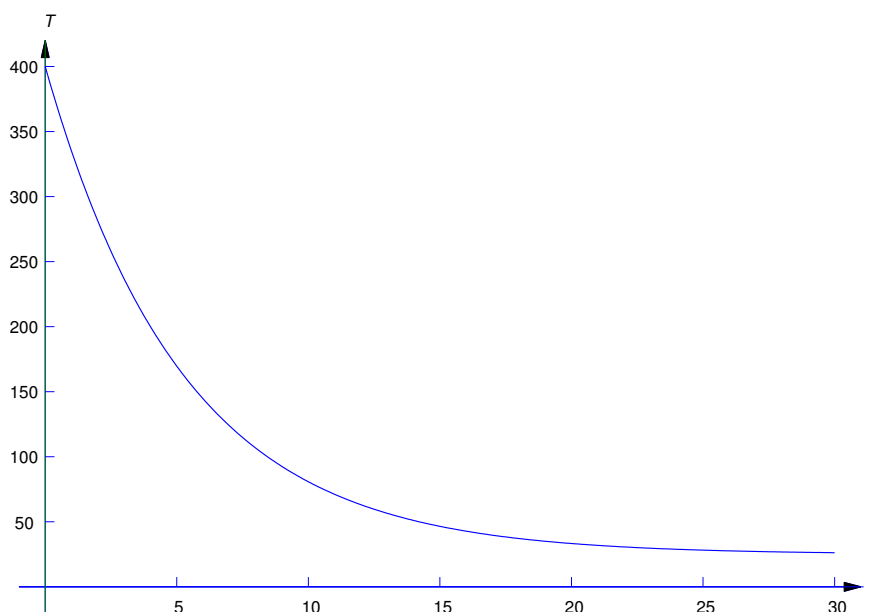
Figure 4.2.1  $T = 25 + 375e^{-(t/4) \ln 15/7}$ 

We obtain  $k$  from the stated condition that the temperature of the object is  $50^\circ\text{F}$  at 11:07. Since 11:07 is  $t = 2$  on our time scale, we can determine  $k$  by substituting  $T = 50$  and  $t = 2$  into (4.2.4) to obtain

$$50 = -20 + 80e^{-2k}$$

(Figure 4.2.2); hence,

$$e^{-2k} = \frac{70}{80} = \frac{7}{8}.$$

Taking logarithms and solving for  $k$  yields

$$k = -\frac{1}{2} \ln \frac{7}{8} = \frac{1}{2} \ln \frac{8}{7}.$$

Substituting this into (4.2.4) yields

$$T = -20 + 80e^{-\frac{t}{2} \ln \frac{8}{7}},$$

and the condition  $T(\tau) = 72$  implies that

$$72 = -20 + 80e^{-\frac{\tau}{2} \ln \frac{8}{7}};$$

hence,

$$e^{-\frac{\tau}{2} \ln \frac{8}{7}} = \frac{92}{80} = \frac{23}{20}.$$

Taking logarithms and solving for  $\tau$  yields

$$\tau = -\frac{2 \ln \frac{23}{20}}{\ln \frac{8}{7}} \approx -2.09 \text{ min.}$$

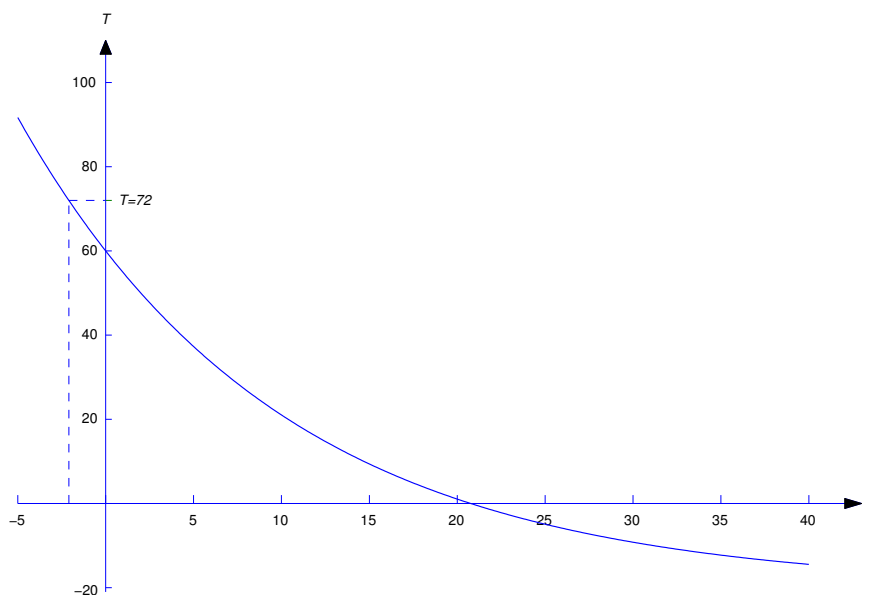
Figure 4.2.2  $T = -20 + 80e^{-\frac{t}{2} \ln \frac{8}{7}}$ 

Therefore the object was placed outside about 2 minutes and 5 seconds before 11:05; that is, at 11:02:55.

### Mixing Problems

In the next two examples a saltwater solution with a given concentration (weight of salt per unit volume of solution) is added at a specified rate to a tank that initially contains saltwater with a different concentration. The problem is to determine the quantity of salt in the tank as a function of time. This is an example of a *mixing problem*. To construct a tractable mathematical model for mixing problems we assume in our examples (and most exercises) that the mixture is stirred instantly so that the salt is always uniformly distributed throughout the mixture. Exercises 22 and 23 deal with situations where this isn't so, but the distribution of salt becomes approximately uniform as  $t \rightarrow \infty$ .

**Example 4.2.3** A tank initially contains 40 pounds of salt dissolved in 600 gallons of water. Starting at  $t_0 = 0$ , water that contains  $1/2$  pound of salt per gallon is poured into the tank at the rate of 4 gal/min and the mixture is drained from the tank at the same rate (Figure 4.2.3).

- Find a differential equation for the quantity  $Q(t)$  of salt in the tank at time  $t > 0$ , and solve the equation to determine  $Q(t)$ .
- Find  $\lim_{t \rightarrow \infty} Q(t)$ .

**SOLUTION(a)** To find a differential equation for  $Q$ , we must use the given information to derive an expression for  $Q'$ . But  $Q'$  is the rate of change of the quantity of salt in the tank changes with respect to time; thus, if *rate in* denotes the rate at which salt enters the tank and *rate out* denotes the rate by which it leaves, then

$$Q' = \text{rate in} - \text{rate out.} \quad (4.2.5)$$

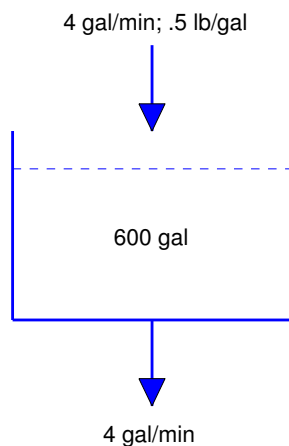

Figure 4.2.3 A mixing problem

The rate in is

$$\left(\frac{1}{2} \text{ lb/gal}\right) \times (4 \text{ gal/min}) = 2 \text{ lb/min.}$$

Determining the rate out requires a little more thought. We're removing 4 gallons of the mixture per minute, and there are always 600 gallons in the tank; that is, we're removing  $1/150$  of the mixture per minute. Since the salt is evenly distributed in the mixture, we are also removing  $1/150$  of the salt per minute. Therefore, if there are  $Q(t)$  pounds of salt in the tank at time  $t$ , the rate out at any time  $t$  is  $Q(t)/150$ . Alternatively, we can arrive at this conclusion by arguing that

$$\begin{aligned} \text{rate out} &= (\text{concentration}) \times (\text{rate of flow out}) \\ &= (\text{lb/gal}) \times (\text{gal/min}) \\ &= \frac{Q(t)}{600} \times 4 = \frac{Q(t)}{150}. \end{aligned}$$

We can now write (4.2.5) as

$$Q' = 2 - \frac{Q}{150}.$$

This first order equation can be rewritten as

$$Q' + \frac{Q}{150} = 2.$$

Since  $e^{-t/150}$  is a solution of the complementary equation, the solutions of this equation are of the form  $Q = ue^{-t/150}$ , where  $u'e^{-t/150} = 2$ , so  $u' = 2e^{t/150}$ . Hence,

$$u = 300e^{t/150} + c,$$

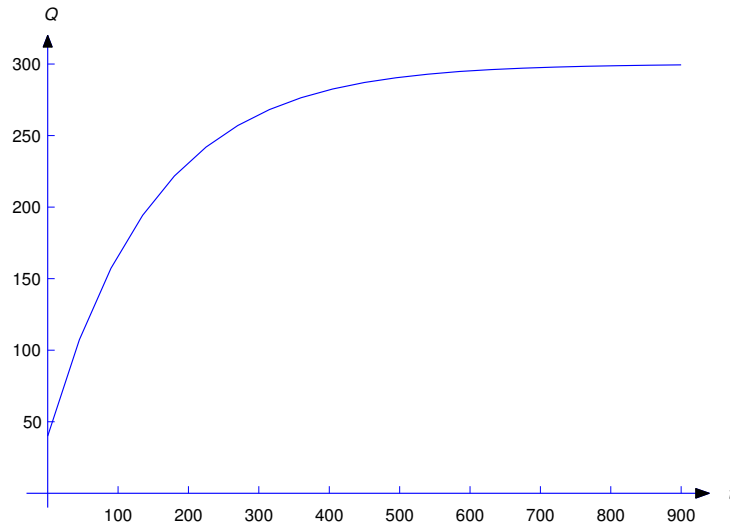
Figure 4.2.4  $Q = 300 - 260e^{-t/150}$ 

so

$$Q = ue^{-t/150} = 300 + ce^{-t/150} \quad (4.2.6)$$

(Figure 4.2.4). Since  $Q(0) = 40$ ,  $c = -260$ ; therefore,

$$Q = 300 - 260e^{-t/150}.$$

**SOLUTION(b)** From (4.2.6), we see that  $\lim_{t \rightarrow \infty} Q(t) = 300$  for any value of  $Q(0)$ . This is intuitively reasonable, since the incoming solution contains 1/2 pound of salt per gallon and there are always 600 gallons of water in the tank.

**Example 4.2.4** A 500-liter tank initially contains 10 g of salt dissolved in 200 liters of water. Starting at  $t_0 = 0$ , water that contains 1/4 g of salt per liter is poured into the tank at the rate of 4 liters/min and the mixture is drained from the tank at the rate of 2 liters/min (Figure 4.2.5). Find a differential equation for the quantity  $Q(t)$  of salt in the tank at time  $t$  prior to the time when the tank overflows and find the concentration  $K(t)$  (g/liter) of salt in the tank at any such time.

**Solution** We first determine the amount  $W(t)$  of solution in the tank at any time  $t$  prior to overflow. Since  $W(0) = 200$  and we're adding 4 liters/min while removing only 2 liters/min, there's a net gain of 2 liters/min in the tank; therefore,

$$W(t) = 2t + 200.$$

Since  $W(150) = 500$  liters (capacity of the tank), this formula is valid for  $0 \leq t \leq 150$ .

Now let  $Q(t)$  be the number of grams of salt in the tank at time  $t$ , where  $0 \leq t \leq 150$ . As in Example 4.2.3,

$$Q' = \text{rate in} - \text{rate out.} \quad (4.2.7)$$

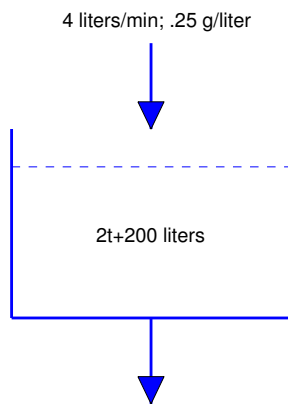

Figure 4.2.5 Another mixing problem

The rate in is

$$\left(\frac{1}{4} \text{ g/liter}\right) \times (4 \text{ liters/min}) = 1 \text{ g/min.} \quad (4.2.8)$$

To determine the rate out, we observe that since the mixture is being removed from the tank at the constant rate of 2 liters/min and there are  $2t + 200$  liters in the tank at time  $t$ , the fraction of the mixture being removed per minute at time  $t$  is

$$\frac{2}{2t + 200} = \frac{1}{t + 100}.$$

We're removing this same fraction of the salt per minute. Therefore, since there are  $Q(t)$  grams of salt in the tank at time  $t$ ,

$$\text{rate out} = \frac{Q(t)}{t + 100}. \quad (4.2.9)$$

Alternatively, we can arrive at this conclusion by arguing that

$$\begin{aligned} \text{rate out} &= (\text{concentration}) \times (\text{rate of flow out}) = (\text{g/liter}) \times (\text{liters/min}) \\ &= \frac{Q(t)}{2t + 200} \times 2 = \frac{Q(t)}{t + 100}. \end{aligned}$$

Substituting (4.2.8) and (4.2.9) into (4.2.7) yields

$$Q' = 1 - \frac{Q}{t + 100}, \quad \text{so} \quad Q' + \frac{1}{t + 100}Q = 1. \quad (4.2.10)$$

By separation of variables,  $1/(t + 100)$  is a solution of the complementary equation, so the solutions of (4.2.10) are of the form

$$Q = \frac{u}{t + 100}, \quad \text{where} \quad \frac{u'}{t + 100} = 1, \quad \text{so} \quad u' = t + 100.$$



Hence,

$$u = \frac{(t + 100)^2}{2} + c. \quad (4.2.11)$$

Since  $Q(0) = 10$  and  $u = (t + 100)Q$ , (4.2.11) implies that

$$(100)(10) = \frac{(100)^2}{2} + c,$$

so

$$c = 100(10) - \frac{(100)^2}{2} = -4000$$

and therefore

$$u = \frac{(t + 100)^2}{2} - 4000.$$

Hence,

$$Q = \frac{u}{t + 200} = \frac{t + 100}{2} - \frac{4000}{t + 100}.$$

Now let  $K(t)$  be the concentration of salt at time  $t$ . Then

$$K(t) = \frac{1}{4} - \frac{2000}{(t + 100)^2}$$

(Figure 4.2.6).

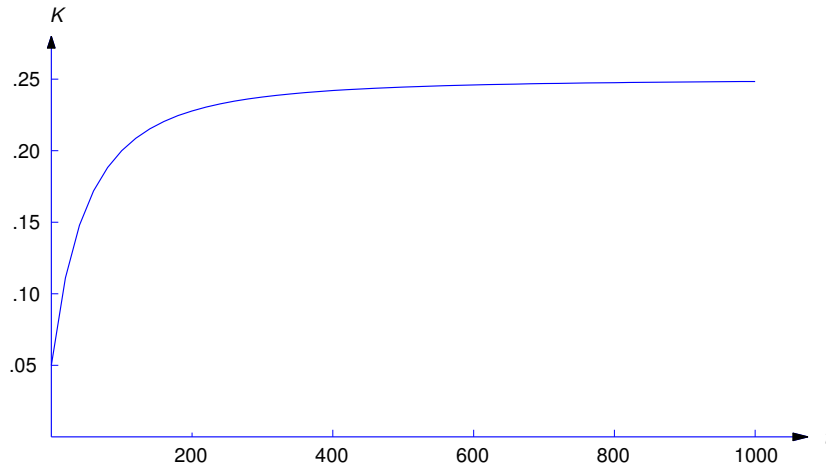

Figure 4.2.6  $K(t) = \frac{1}{4} - \frac{2000}{(t + 100)^2}$

## 4.2 Exercises

---

1. A thermometer is moved from a room where the temperature is  $70^{\circ}\text{F}$  to a freezer where the temperature is  $12^{\circ}\text{F}$ . After 30 seconds the thermometer reads  $40^{\circ}\text{F}$ . What does it read after 2 minutes?
2. A fluid initially at  $100^{\circ}\text{C}$  is placed outside on a day when the temperature is  $-10^{\circ}\text{C}$ , and the temperature of the fluid drops  $20^{\circ}\text{C}$  in one minute. Find the temperature  $T(t)$  of the fluid for  $t > 0$ .
3. At 12:00 PM a thermometer reading  $10^{\circ}\text{F}$  is placed in a room where the temperature is  $70^{\circ}\text{F}$ . It reads  $56^{\circ}$  when it's placed outside, where the temperature is  $5^{\circ}\text{F}$ , at 12:03. What does it read at 12:05 PM?
4. A thermometer initially reading  $212^{\circ}\text{F}$  is placed in a room where the temperature is  $70^{\circ}\text{F}$ . After 2 minutes the thermometer reads  $125^{\circ}\text{F}$ .
  - (a) What does the thermometer read after 4 minutes?
  - (b) When will the thermometer read  $72^{\circ}\text{F}$ ?
  - (c) When will the thermometer read  $69^{\circ}\text{F}$ ?
5. An object with initial temperature  $150^{\circ}\text{C}$  is placed outside, where the temperature is  $35^{\circ}\text{C}$ . Its temperatures at 12:15 and 12:20 are  $120^{\circ}\text{C}$  and  $90^{\circ}\text{C}$ , respectively.
  - (a) At what time was the object placed outside?
  - (b) When will its temperature be  $40^{\circ}\text{C}$ ?
6. An object is placed in a room where the temperature is  $20^{\circ}\text{C}$ . The temperature of the object drops by  $5^{\circ}\text{C}$  in 4 minutes and by  $7^{\circ}\text{C}$  in 8 minutes. What was the temperature of the object when it was initially placed in the room?
7. A cup of boiling water is placed outside at 1:00 PM. One minute later the temperature of the water is  $152^{\circ}\text{F}$ . After another minute its temperature is  $112^{\circ}\text{F}$ . What is the outside temperature?
8. A tank initially contains 40 gallons of pure water. A solution with 1 gram of salt per gallon of water is added to the tank at 3 gal/min, and the resulting solution drains out at the same rate. Find the quantity  $Q(t)$  of salt in the tank at time  $t > 0$ .
9. A tank initially contains a solution of 10 pounds of salt in 60 gallons of water. Water with  $1/2$  pound of salt per gallon is added to the tank at 6 gal/min, and the resulting solution leaves at the same rate. Find the quantity  $Q(t)$  of salt in the tank at time  $t > 0$ .
10. A tank initially contains 100 liters of a salt solution with a concentration of .1 g/liter. A solution with a salt concentration of .3 g/liter is added to the tank at 5 liters/min, and the resulting mixture is drained out at the same rate. Find the concentration  $K(t)$  of salt in the tank as a function of  $t$ .
11. A 200 gallon tank initially contains 100 gallons of water with 20 pounds of salt. A salt solution with  $1/4$  pound of salt per gallon is added to the tank at 4 gal/min, and the resulting mixture is drained out at 2 gal/min. Find the quantity of salt in the tank as it's about to overflow.
12. Suppose water is added to a tank at 10 gal/min, but leaks out at the rate of  $1/5$  gal/min for each gallon in the tank. What is the smallest capacity the tank can have if the process is to continue indefinitely?
13. A chemical reaction in a laboratory with volume  $V$  (in  $\text{ft}^3$ ) produces  $q_1 \text{ ft}^3/\text{min}$  of a noxious gas as a byproduct. The gas is dangerous at concentrations greater than  $\bar{c}$ , but harmless at concentrations  $\leq \bar{c}$ . Intake fans at one end of the laboratory pull in fresh air at the rate of  $q_2 \text{ ft}^3/\text{min}$  and exhaust fans at the other end exhaust the mixture of gas and air from the laboratory at the same rate.

Assuming that the gas is always uniformly distributed in the room and its initial concentration  $c_0$  is at a safe level, find the smallest value of  $q_2$  required to maintain safe conditions in the laboratory for all time.

14. A 1200-gallon tank initially contains 40 pounds of salt dissolved in 600 gallons of water. Starting at  $t_0 = 0$ , water that contains 1/2 pound of salt per gallon is added to the tank at the rate of 6 gal/min and the resulting mixture is drained from the tank at 4 gal/min. Find the quantity  $Q(t)$  of salt in the tank at any time  $t > 0$  prior to overflow.
15. Tank  $T_1$  initially contain 50 gallons of pure water. Starting at  $t_0 = 0$ , water that contains 1 pound of salt per gallon is poured into  $T_1$  at the rate of 2 gal/min. The mixture is drained from  $T_1$  at the same rate into a second tank  $T_2$ , which initially contains 50 gallons of pure water. Also starting at  $t_0 = 0$ , a mixture from another source that contains 2 pounds of salt per gallon is poured into  $T_2$  at the rate of 2 gal/min. The mixture is drained from  $T_2$  at the rate of 4 gal/min.
- Find a differential equation for the quantity  $Q(t)$  of salt in tank  $T_2$  at time  $t > 0$ .
  - Solve the equation derived in (a) to determine  $Q(t)$ .
  - Find  $\lim_{t \rightarrow \infty} Q(t)$ .
16. Suppose an object with initial temperature  $T_0$  is placed in a sealed container, which is in turn placed in a medium with temperature  $T_m$ . Let the initial temperature of the container be  $S_0$ . Assume that the temperature of the object does not affect the temperature of the container, which in turn does not affect the temperature of the medium. (These assumptions are reasonable, for example, if the object is a cup of coffee, the container is a house, and the medium is the atmosphere.)
- Assuming that the container and the medium have distinct temperature decay constants  $k$  and  $k_m$  respectively, use Newton's law of cooling to find the temperatures  $S(t)$  and  $T(t)$  of the container and object at time  $t$ .
  - Assuming that the container and the medium have the same temperature decay constant  $k$ , use Newton's law of cooling to find the temperatures  $S(t)$  and  $T(t)$  of the container and object at time  $t$ .
  - Find  $\lim_{t \rightarrow \infty} S(t)$  and  $\lim_{t \rightarrow \infty} T(t)$ .
17. In our previous examples and exercises concerning Newton's law of cooling we assumed that the temperature of the medium remains constant. This model is adequate if the heat lost or gained by the object is insignificant compared to the heat required to cause an appreciable change in the temperature of the medium. If this isn't so, we must use a model that accounts for the heat exchanged between the object and the medium. Let  $T = T(t)$  and  $T_m = T_m(t)$  be the temperatures of the object and the medium, respectively, and let  $T_0$  and  $T_{m0}$  be their initial values. Again, we assume that  $T$  and  $T_m$  are related by Newton's law of cooling,

$$T' = -k(T - T_m). \quad (\text{A})$$

We also assume that the change in heat of the object as its temperature changes from  $T_0$  to  $T$  is  $a(T - T_0)$  and that the change in heat of the medium as its temperature changes from  $T_{m0}$  to  $T_m$  is  $a_m(T_m - T_{m0})$ , where  $a$  and  $a_m$  are positive constants depending upon the masses and thermal properties of the object and medium, respectively. If we assume that the total heat of the system consisting of the object and the medium remains constant (that is, energy is conserved), then

$$a(T - T_0) + a_m(T_m - T_{m0}) = 0. \quad (\text{B})$$

- Equation (A) involves two unknown functions  $T$  and  $T_m$ . Use (A) and (B) to derive a differential equation involving only  $T$ .

- (b) Find  $T(t)$  and  $T_m(t)$  for  $t > 0$ .  
 (c) Find  $\lim_{t \rightarrow \infty} T(t)$  and  $\lim_{t \rightarrow \infty} T_m(t)$ .
18. Control mechanisms allow fluid to flow into a tank at a rate proportional to the volume  $V$  of fluid in the tank, and to flow out at a rate proportional to  $V^2$ . Suppose  $V(0) = V_0$  and the constants of proportionality are  $a$  and  $b$ , respectively. Find  $V(t)$  for  $t > 0$  and find  $\lim_{t \rightarrow \infty} V(t)$ .
19. Identical tanks  $T_1$  and  $T_2$  initially contain  $W$  gallons each of pure water. Starting at  $t_0 = 0$ , a salt solution with constant concentration  $c$  is pumped into  $T_1$  at  $r$  gal/min and drained from  $T_1$  into  $T_2$  at the same rate. The resulting mixture in  $T_2$  is also drained at the same rate. Find the concentrations  $c_1(t)$  and  $c_2(t)$  in tanks  $T_1$  and  $T_2$  for  $t > 0$ .
20. An infinite sequence of identical tanks  $T_1, T_2, \dots, T_n, \dots$ , initially contain  $W$  gallons each of pure water. They are hooked together so that fluid drains from  $T_n$  into  $T_{n+1}$  ( $n = 1, 2, \dots$ ). A salt solution is circulated through the tanks so that it enters and leaves each tank at the constant rate of  $r$  gal/min. The solution has a concentration of  $c$  pounds of salt per gallon when it enters  $T_1$ .
- (a) Find the concentration  $c_n(t)$  in tank  $T_n$  for  $t > 0$ .  
 (b) Find  $\lim_{t \rightarrow \infty} c_n(t)$  for each  $n$ .
21. Tanks  $T_1$  and  $T_2$  have capacities  $W_1$  and  $W_2$  liters, respectively. Initially they are both full of dye solutions with concentrations  $c_1$  and  $c_2$  grams per liter. Starting at  $t_0 = 0$ , the solution from  $T_1$  is pumped into  $T_2$  at a rate of  $r$  liters per minute, and the solution from  $T_2$  is pumped into  $T_1$  at the same rate.
- (a) Find the concentrations  $c_1(t)$  and  $c_2(t)$  of the dye in  $T_1$  and  $T_2$  for  $t > 0$ .  
 (b) Find  $\lim_{t \rightarrow \infty} c_1(t)$  and  $\lim_{t \rightarrow \infty} c_2(t)$ .
22. **L** Consider the mixing problem of Example 4.2.3, but without the assumption that the mixture is stirred instantly so that the salt is always uniformly distributed throughout the mixture. Assume instead that the distribution approaches uniformity as  $t \rightarrow \infty$ . In this case the differential equation for  $Q$  is of the form

$$Q' + \frac{a(t)}{150}Q = 2$$

where  $\lim_{t \rightarrow \infty} a(t) = 1$ .

- (a) Assuming that  $Q(0) = Q_0$ , can you guess the value of  $\lim_{t \rightarrow \infty} Q(t)$ ?  
 (b) Use numerical methods to confirm your guess in the these cases:
- (i)  $a(t) = t/(1+t)$  (ii)  $a(t) = 1 - e^{-t^2}$  (iii)  $a(t) = 1 - \sin(e^{-t})$ .
23. **L** Consider the mixing problem of Example 4.2.4 in a tank with infinite capacity, but without the assumption that the mixture is stirred instantly so that the salt is always uniformly distributed throughout the mixture. Assume instead that the distribution approaches uniformity as  $t \rightarrow \infty$ . In this case the differential equation for  $Q$  is of the form

$$Q' + \frac{a(t)}{t+100}Q = 1$$

where  $\lim_{t \rightarrow \infty} a(t) = 1$ .

- (a) Let  $K(t)$  be the concentration of salt at time  $t$ . Assuming that  $Q(0) = Q_0$ , can you guess the value of  $\lim_{t \rightarrow \infty} K(t)$ ?  
 (b) Use numerical methods to confirm your guess in the these cases:

(i)  $a(t) = t/(1+t)$  (ii)  $a(t) = 1 - e^{-t^2}$  (iii)  $a(t) = 1 + \sin(e^{-t})$ .

### 4.3 ELEMENTARY MECHANICS

#### Newton's Second Law of Motion

In this section we consider an object with constant mass  $m$  moving along a line under a force  $F$ . Let  $y = y(t)$  be the displacement of the object from a reference point on the line at time  $t$ , and let  $v = v(t)$  and  $a = a(t)$  be the velocity and acceleration of the object at time  $t$ . Thus,  $v = y'$  and  $a = v' = y''$ , where the prime denotes differentiation with respect to  $t$ . Newton's second law of motion asserts that the force  $F$  and the acceleration  $a$  are related by the equation

$$F = ma. \quad (4.3.1)$$

#### Units

In applications there are three main sets of units in use for length, mass, force, and time: the cgs, mks, and British systems. All three use the second as the unit of time. Table 1 shows the other units. Consistent with (4.3.1), the unit of force in each system is defined to be the force required to impart an acceleration of (one unit of length)/ $s^2$  to one unit of mass.

	Length	Force	Mass
cgs	centimeter (cm)	dyne (d)	gram (g)
mks	meter (m)	newton (N)	kilogram (kg)
British	foot (ft)	pound (lb)	slug (sl)

Table 1.

If we assume that Earth is a perfect sphere with constant mass density, Newton's law of gravitation (discussed later in this section) asserts that the force exerted on an object by Earth's gravitational field is proportional to the mass of the object and inversely proportional to the square of its distance from the center of Earth. However, if the object remains sufficiently close to Earth's surface, we may assume that the gravitational force is constant and equal to its value at the surface. The magnitude of this force is  $mg$ , where  $g$  is called the *acceleration due to gravity*. (To be completely accurate,  $g$  should be called the *magnitude of the acceleration due to gravity at Earth's surface*.) This quantity has been determined experimentally. Approximate values of  $g$  are

$$\begin{aligned} g &= 980 \text{ cm/s}^2 && \text{(cgs)} \\ g &= 9.8 \text{ m/s}^2 && \text{(mks)} \\ g &= 32 \text{ ft/s}^2 && \text{(British)}. \end{aligned}$$

In general, the force  $F$  in (4.3.1) may depend upon  $t$ ,  $y$ , and  $y'$ . Since  $a = y''$ , (4.3.1) can be written in the form

$$my'' = F(t, y, y'), \quad (4.3.2)$$

which is a second order equation. We'll consider this equation with restrictions on  $F$  later; however, since Chapter 2 dealt only with first order equations, we consider here only problems in which (4.3.2) can be recast as a first order equation. This is possible if  $F$  does not depend on  $y$ , so (4.3.2) is of the form

$$my'' = F(t, y').$$

Letting  $v = y'$  and  $v' = y''$  yields a first order equation for  $v$ :

$$mv' = F(t, v). \quad (4.3.3)$$

Solving this equation yields  $v$  as a function of  $t$ . If we know  $y(t_0)$  for some time  $t_0$ , we can integrate  $v$  to obtain  $y$  as a function of  $t$ .

Equations of the form (4.3.3) occur in problems involving motion through a resisting medium.

### Motion Through a Resisting Medium Under Constant Gravitational Force

Now we consider an object moving vertically in some medium. We assume that the only forces acting on the object are gravity and resistance from the medium. We also assume that the motion takes place close to Earth's surface and take the upward direction to be positive, so the gravitational force can be assumed to have the constant value  $-mg$ . We'll see that, under reasonable assumptions on the resisting force, the velocity approaches a limit as  $t \rightarrow \infty$ . We call this limit the *terminal velocity*.

**Example 4.3.1** An object with mass  $m$  moves under constant gravitational force through a medium that exerts a resistance with magnitude proportional to the speed of the object. (Recall that the speed of an object is  $|v|$ , the absolute value of its velocity  $v$ .) Find the velocity of the object as a function of  $t$ , and find the terminal velocity. Assume that the initial velocity is  $v_0$ .

**Solution** The total force acting on the object is

$$F = -mg + F_1, \quad (4.3.4)$$

where  $-mg$  is the force due to gravity and  $F_1$  is the resisting force of the medium, which has magnitude  $k|v|$ , where  $k$  is a positive constant. If the object is moving downward ( $v \leq 0$ ), the resisting force is upward (Figure 4.3.1(a)), so

$$F_1 = k|v| = k(-v) = -kv.$$

On the other hand, if the object is moving upward ( $v \geq 0$ ), the resisting force is downward (Figure 4.3.1(b)), so

$$F_1 = -k|v| = -kv.$$

Thus, (4.3.4) can be written as

$$F = -mg - kv, \quad (4.3.5)$$

regardless of the sign of the velocity.

From Newton's second law of motion,

$$F = ma = mv',$$

so (4.3.5) yields

$$mv' = -mg - kv,$$

or

$$v' + \frac{k}{m}v = -g. \quad (4.3.6)$$

Since  $e^{-kt/m}$  is a solution of the complementary equation, the solutions of (4.3.6) are of the form  $v = ue^{-kt/m}$ , where  $u'e^{-kt/m} = -g$ , so  $u' = -ge^{kt/m}$ . Hence,

$$u = -\frac{mg}{k}e^{kt/m} + c,$$

so

$$v = ue^{-kt/m} = -\frac{mg}{k} + ce^{-kt/m}. \quad (4.3.7)$$

Since  $v(0) = v_0$ ,

$$v_0 = -\frac{mg}{k} + c,$$

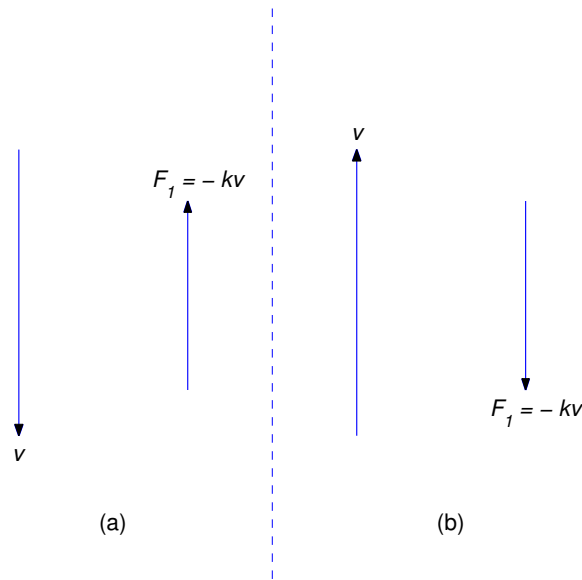

Figure 4.3.1 Resistive forces

so

$$c = v_0 + \frac{mg}{k}$$

and (4.3.7) becomes

$$v = -\frac{mg}{k} + \left(v_0 + \frac{mg}{k}\right) e^{-kt/m}.$$

Letting  $t \rightarrow \infty$  here shows that the terminal velocity is

$$\lim_{t \rightarrow \infty} v(t) = -\frac{mg}{k},$$

which is independent of the initial velocity  $v_0$  (Figure 4.3.2).

**Example 4.3.2** A 960-lb object is given an initial upward velocity of 60 ft/s near the surface of Earth. The atmosphere resists the motion with a force of 3 lb for each ft/s of speed. Assuming that the only other force acting on the object is constant gravity, find its velocity  $v$  as a function of  $t$ , and find its terminal velocity.

**Solution** Since  $mg = 960$  and  $g = 32$ ,  $m = 960/32 = 30$ . The atmospheric resistance is  $-3v$  lb if  $v$  is expressed in feet per second. Therefore

$$30v' = -960 - 3v,$$

which we rewrite as

$$v' + \frac{1}{10}v = -32.$$

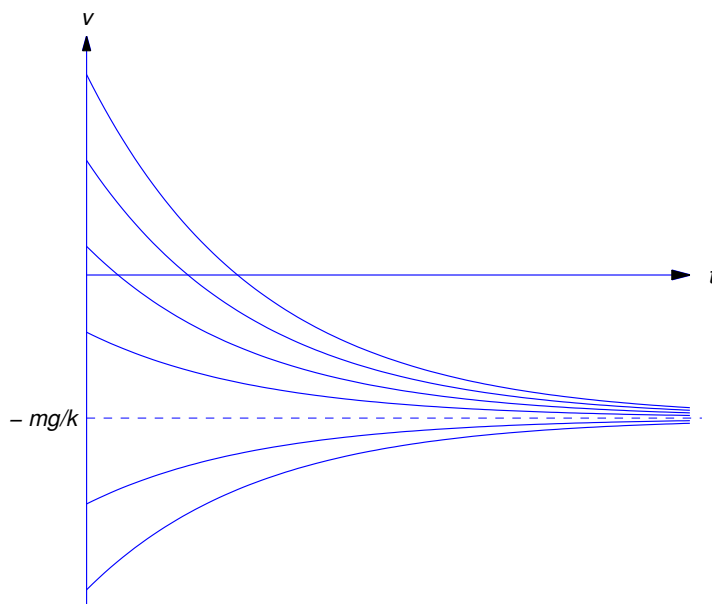
Figure 4.3.2 Solutions of  $mv' = -mg - kv$ 

Since  $e^{-t/10}$  is a solution of the complementary equation, the solutions of this equation are of the form  $v = ue^{-t/10}$ , where  $u'e^{-t/10} = -32$ , so  $u' = -32e^{t/10}$ . Hence,

$$u = -320e^{t/10} + c,$$

so

$$v = ue^{-t/10} = -320 + ce^{-t/10}. \quad (4.3.8)$$

The initial velocity is 60 ft/s in the upward (positive) direction; hence,  $v_0 = 60$ . Substituting  $t = 0$  and  $v = 60$  in (4.3.8) yields

$$60 = -320 + c,$$

so  $c = 380$ , and (4.3.8) becomes

$$v = -320 + 380e^{-t/10} \text{ ft/s}$$

The terminal velocity is

$$\lim_{t \rightarrow \infty} v(t) = -320 \text{ ft/s.}$$

**Example 4.3.3** A 10 kg mass is given an initial velocity  $v_0 \leq 0$  near Earth's surface. The only forces acting on it are gravity and atmospheric resistance proportional to the square of the speed. Assuming that the resistance is 8 N if the speed is 2 m/s, find the velocity of the object as a function of  $t$ , and find the terminal velocity.

**Solution** Since the object is falling, the resistance is in the upward (positive) direction. Hence,

$$mv' = -mg + kv^2, \quad (4.3.9)$$



where  $k$  is a constant. Since the magnitude of the resistance is 8 N when  $v = 2$  m/s,

$$k(2^2) = 8,$$

so  $k = 2 \text{ N}\cdot\text{s}^2/\text{m}^2$ . Since  $m = 10$  and  $g = 9.8$ , (4.3.9) becomes

$$10v' = -98 + 2v^2 = 2(v^2 - 49). \quad (4.3.10)$$

If  $v_0 = -7$ , then  $v \equiv -7$  for all  $t \geq 0$ . If  $v_0 \neq -7$ , we separate variables to obtain

$$\frac{1}{v^2 - 49} v' = \frac{1}{5}, \quad (4.3.11)$$

which is convenient for the required partial fraction expansion

$$\frac{1}{v^2 - 49} = \frac{1}{(v - 7)(v + 7)} = \frac{1}{14} \left[ \frac{1}{v - 7} - \frac{1}{v + 7} \right]. \quad (4.3.12)$$

Substituting (4.3.12) into (4.3.11) yields

$$\frac{1}{14} \left[ \frac{1}{v - 7} - \frac{1}{v + 7} \right] v' = \frac{1}{5},$$

so

$$\left[ \frac{1}{v - 7} - \frac{1}{v + 7} \right] v' = \frac{14}{5}.$$

Integrating this yields

$$\ln |v - 7| - \ln |v + 7| = 14t/5 + k.$$

Therefore

$$\left| \frac{v - 7}{v + 7} \right| = e^k e^{14t/5}.$$

Since Theorem 2.3.1 implies that  $(v - 7)/(v + 7)$  can't change sign (why?), we can rewrite the last equation as

$$\frac{v - 7}{v + 7} = ce^{14t/5}, \quad (4.3.13)$$

which is an implicit solution of (4.3.10). Solving this for  $v$  yields

$$v = -7 \frac{c + e^{-14t/5}}{c - e^{-14t/5}}. \quad (4.3.14)$$

Since  $v(0) = v_0$ , it (4.3.13) implies that

$$c = \frac{v_0 - 7}{v_0 + 7}.$$

Substituting this into (4.3.14) and simplifying yields

$$v = -7 \frac{v_0(1 + e^{-14t/5}) - 7(1 - e^{-14t/5})}{v_0(1 - e^{-14t/5}) - 7(1 + e^{-14t/5})}.$$

Since  $v_0 \leq 0$ ,  $v$  is defined and negative for all  $t > 0$ . The terminal velocity is

$$\lim_{t \rightarrow \infty} v(t) = -7 \text{ m/s},$$

independent of  $v_0$ . More generally, it can be shown (Exercise 11) that if  $v$  is any solution of (4.3.9) such that  $v_0 \leq 0$  then

$$\lim_{t \rightarrow \infty} v(t) = -\sqrt{\frac{mg}{k}}$$

(Figure 4.3.3).

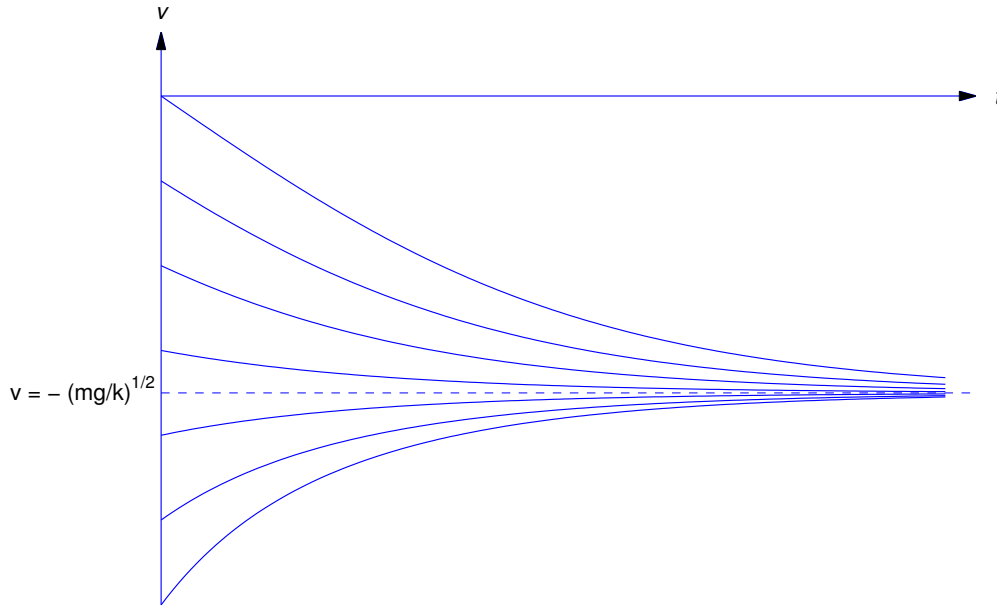
Figure 4.3.3 Solutions of  $mv' = -mg + kv^2$ ,  $v(0) = v_0 \leq 0$ 

**Example 4.3.4** A 10-kg mass is launched vertically upward from Earth's surface with an initial velocity of  $v_0$  m/s. The only forces acting on the mass are gravity and atmospheric resistance proportional to the square of the speed. Assuming that the atmospheric resistance is 8 N if the speed is 2 m/s, find the time  $T$  required for the mass to reach maximum altitude.

**Solution** The mass will climb while  $v > 0$  and reach its maximum altitude when  $v = 0$ . Therefore  $v > 0$  for  $0 \leq t < T$  and  $v(T) = 0$ . Although the mass of the object and our assumptions concerning the forces acting on it are the same as those in Example 3, (4.3.10) does not apply here, since the resisting force is negative if  $v > 0$ ; therefore, we replace (4.3.10) by

$$10v' = -98 - 2v^2. \quad (4.3.15)$$

Separating variables yields

$$\frac{5}{v^2 + 49}v' = -1,$$

and integrating this yields

$$\frac{5}{7} \tan^{-1} \frac{v}{7} = -t + c.$$

(Recall that  $\tan^{-1} u$  is the number  $\theta$  such that  $-\pi/2 < \theta < \pi/2$  and  $\tan \theta = u$ .) Since  $v(0) = v_0$ ,

$$c = \frac{5}{7} \tan^{-1} \frac{v_0}{7},$$

so  $v$  is defined implicitly by

$$\frac{5}{7} \tan^{-1} \frac{v}{7} = -t + \frac{5}{7} \tan^{-1} \frac{v_0}{7}, \quad 0 \leq t \leq T. \quad (4.3.16)$$

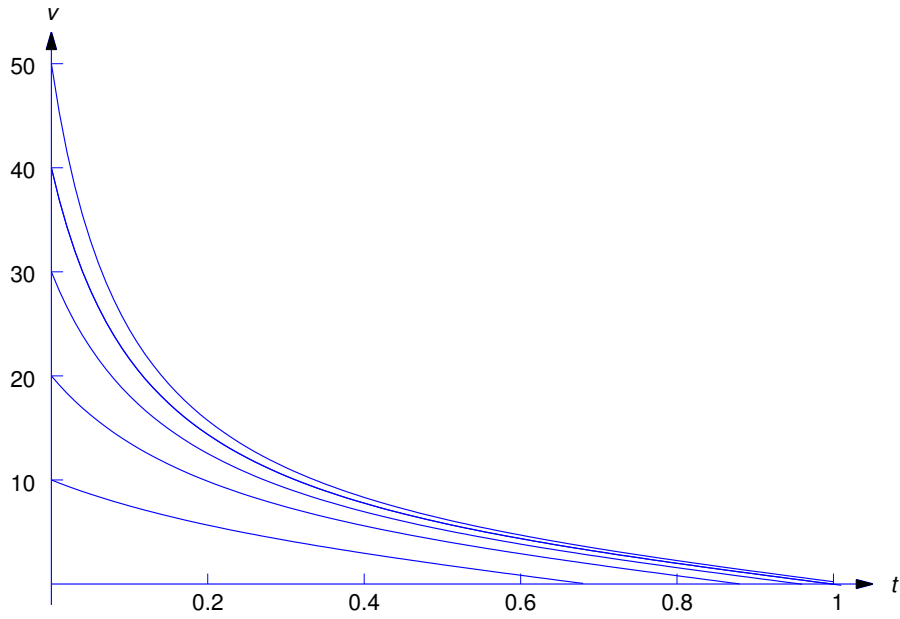
Figure 4.3.4 Solutions of (4.3.15) for various  $v_0 > 0$ 

Solving this for  $v$  yields

$$v = 7 \tan \left( -\frac{7t}{5} + \tan^{-1} \frac{v_0}{7} \right). \quad (4.3.17)$$

Using the identity

$$\tan(A - B) = \frac{\tan A - \tan B}{1 + \tan A \tan B}$$

with  $A = \tan^{-1}(v_0/7)$  and  $B = 7t/5$ , and noting that  $\tan(\tan^{-1} \theta) = \theta$ , we can simplify (4.3.17) to

$$v = 7 \frac{v_0 - 7 \tan(7t/5)}{7 + v_0 \tan(7t/5)}.$$

Since  $v(T) = 0$  and  $\tan^{-1}(0) = 0$ , (4.3.16) implies that

$$-T + \frac{5}{7} \tan^{-1} \frac{v_0}{7} = 0.$$

Therefore

$$T = \frac{5}{7} \tan^{-1} \frac{v_0}{7}.$$

Since  $\tan^{-1}(v_0/7) < \pi/2$  for all  $v_0$ , the time required for the mass to reach its maximum altitude is less than

$$\frac{5\pi}{14} \approx 1.122 \text{ s}$$

regardless of the initial velocity. Figure 4.3.4 shows graphs of  $v$  over  $[0, T]$  for various values of  $v_0$ .

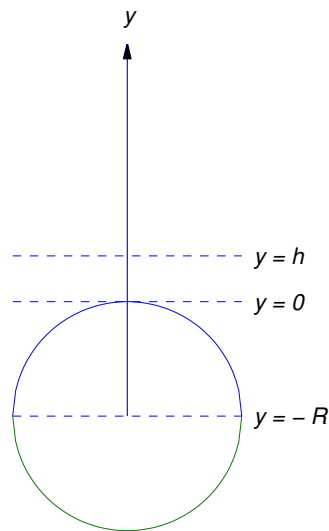

Figure 4.3.5 Escape velocity

### Escape Velocity

Suppose a space vehicle is launched vertically and its fuel is exhausted when the vehicle reaches an altitude  $h$  above Earth, where  $h$  is sufficiently large so that resistance due to Earth's atmosphere can be neglected. Let  $t = 0$  be the time when burnout occurs. Assuming that the gravitational forces of all other celestial bodies can be neglected, the motion of the vehicle for  $t > 0$  is that of an object with constant mass  $m$  under the influence of Earth's gravitational force, which we now assume to vary inversely with the square of the distance from Earth's center; thus, if we take the upward direction to be positive then gravitational force on the vehicle at an altitude  $y$  above Earth is

$$F = -\frac{K}{(y + R)^2}, \quad (4.3.18)$$

where  $R$  is Earth's radius (Figure 4.3.5).

Since  $F = -mg$  when  $y = 0$ , setting  $y = 0$  in (4.3.18) yields

$$-mg = -\frac{K}{R^2};$$

therefore  $K = mgR^2$  and (4.3.18) can be written more specifically as

$$F = -\frac{mgR^2}{(y + R)^2}. \quad (4.3.19)$$

From Newton's second law of motion,

$$F = m\frac{d^2y}{dt^2},$$

so (4.3.19) implies that

$$\frac{d^2y}{dt^2} = -\frac{gR^2}{(y+R)^2}. \quad (4.3.20)$$

We'll show that there's a number  $v_e$ , called the *escape velocity*, with these properties:

1. If  $v_0 \geq v_e$  then  $v(t) > 0$  for all  $t > 0$ , and the vehicle continues to climb for all  $t > 0$ ; that is, it "escapes" Earth. (Is it really so obvious that  $\lim_{t \rightarrow \infty} y(t) = \infty$  in this case? For a proof, see Exercise 20.)
2. If  $v_0 < v_e$  then  $v(t)$  decreases to zero and becomes negative. Therefore the vehicle attains a maximum altitude  $y_m$  and falls back to Earth.

Since (4.3.20) is second order, we can't solve it by methods discussed so far. However, we're concerned with  $v$  rather than  $y$ , and  $v$  is easier to find. Since  $v = y'$  the chain rule implies that

$$\frac{d^2y}{dt^2} = \frac{dv}{dt} = \frac{dv}{dy} \frac{dy}{dt} = v \frac{dv}{dy}.$$

Substituting this into (4.3.20) yields the first order separable equation

$$v \frac{dv}{dy} = -\frac{gR^2}{(y+R)^2}. \quad (4.3.21)$$

When  $t = 0$ , the velocity is  $v_0$  and the altitude is  $h$ . Therefore we can obtain  $v$  as a function of  $y$  by solving the initial value problem

$$v \frac{dv}{dy} = -\frac{gR^2}{(y+R)^2}, \quad v(h) = v_0.$$

Integrating (4.3.21) with respect to  $y$  yields

$$\frac{v^2}{2} = \frac{gR^2}{y+R} + c. \quad (4.3.22)$$

Since  $v(h) = v_0$ ,

$$c = \frac{v_0^2}{2} - \frac{gR^2}{h+R},$$

so (4.3.22) becomes

$$\frac{v^2}{2} = \frac{gR^2}{y+R} + \left( \frac{v_0^2}{2} - \frac{gR^2}{h+R} \right). \quad (4.3.23)$$

If

$$v_0 \geq \left( \frac{2gR^2}{h+R} \right)^{1/2},$$

the parenthetical expression in (4.3.23) is nonnegative, so  $v(y) > 0$  for  $y > h$ . This proves that there's an escape velocity  $v_e$ . We'll now prove that

$$v_e = \left( \frac{2gR^2}{h+R} \right)^{1/2}$$

by showing that the vehicle falls back to Earth if

$$v_0 < \left( \frac{2gR^2}{h+R} \right)^{1/2}. \quad (4.3.24)$$

If (4.3.24) holds then the parenthetical expression in (4.3.23) is negative and the vehicle will attain a maximum altitude  $y_m > h$  that satisfies the equation

$$0 = \frac{gR^2}{y_m + R} + \left( \frac{v_0^2}{2} - \frac{gR^2}{h + R} \right).$$

The velocity will be zero at the maximum altitude, and the object will then fall to Earth under the influence of gravity.

### 4.3 Exercises

---

Except where directed otherwise, assume that the magnitude of the gravitational force on an object with mass  $m$  is constant and equal to  $mg$ . In exercises involving vertical motion take the upward direction to be positive.

1. A firefighter who weighs 192 lb slides down an infinitely long fire pole that exerts a frictional resistive force with magnitude proportional to his speed, with  $k = 2.5$  lb-s/ft. Assuming that he starts from rest, find his velocity as a function of time and find his terminal velocity.
2. A firefighter who weighs 192 lb slides down an infinitely long fire pole that exerts a frictional resistive force with magnitude proportional to her speed, with constant of proportionality  $k$ . Find  $k$ , given that her terminal velocity is -16 ft/s, and then find her velocity  $v$  as a function of  $t$ . Assume that she starts from rest.
3. A boat weighs 64,000 lb. Its propellor produces a constant thrust of 50,000 lb and the water exerts a resistive force with magnitude proportional to the speed, with  $k = 2000$  lb-s/ft. Assuming that the boat starts from rest, find its velocity as a function of time, and find its terminal velocity.
4. A constant horizontal force of 10 N pushes a 20 kg-mass through a medium that resists its motion with .5 N for every m/s of speed. The initial velocity of the mass is 7 m/s in the direction opposite to the direction of the applied force. Find the velocity of the mass for  $t > 0$ .
5. A stone weighing 1/2 lb is thrown upward from an initial height of 5 ft with an initial speed of 32 ft/s. Air resistance is proportional to speed, with  $k = 1/128$  lb-s/ft. Find the maximum height attained by the stone.
6. A 3200-lb car is moving at 64 ft/s down a 30-degree grade when it runs out of fuel. Find its velocity after that if friction exerts a resistive force with magnitude proportional to the square of the speed, with  $k = 1$  lb-s<sup>2</sup>/ft<sup>2</sup>. Also find its terminal velocity.
7. A 96 lb weight is dropped from rest in a medium that exerts a resistive force with magnitude proportional to the speed. Find its velocity as a function of time if its terminal velocity is -128 ft/s.
8. An object with mass  $m$  moves vertically through a medium that exerts a resistive force with magnitude proportional to the speed. Let  $y = y(t)$  be the altitude of the object at time  $t$ , with  $y(0) = y_0$ . Use the results of Example 4.3.1 to show that

$$y(t) = y_0 + \frac{m}{k}(v_0 - v - gt).$$

9. An object with mass  $m$  is launched vertically upward with initial velocity  $v_0$  from Earth's surface ( $y_0 = 0$ ) in a medium that exerts a resistive force with magnitude proportional to the speed. Find the time  $T$  when the object attains its maximum altitude  $y_m$ . Then use the result of Exercise 8 to find  $y_m$ .

10. An object weighing 256 lb is dropped from rest in a medium that exerts a resistive force with magnitude proportional to the square of the speed. The magnitude of the resisting force is 1 lb when  $|v| = 4$  ft/s. Find  $v$  for  $t > 0$ , and find its terminal velocity.
11. An object with mass  $m$  is given an initial velocity  $v_0 \leq 0$  in a medium that exerts a resistive force with magnitude proportional to the square of the speed. Find the velocity of the object for  $t > 0$ , and find its terminal velocity.
12. An object with mass  $m$  is launched vertically upward with initial velocity  $v_0$  in a medium that exerts a resistive force with magnitude proportional to the square of the speed.
- Find the time  $T$  when the object reaches its maximum altitude.
  - Use the result of Exercise 11 to find the velocity of the object for  $t > T$ .
13. **L** An object with mass  $m$  is given an initial velocity  $v_0 \leq 0$  in a medium that exerts a resistive force of the form  $a|v|/(1 + |v|)$ , where  $a$  is positive constant.
- Set up a differential equation for the speed of the object.
  - Use your favorite numerical method to solve the equation you found in (a), to convince yourself that there's a unique number  $a_0$  such that  $\lim_{t \rightarrow \infty} s(t) = \infty$  if  $a \leq a_0$  and  $\lim_{t \rightarrow \infty} s(t)$  exists (finite) if  $a > a_0$ . (We say that  $a_0$  is the *bifurcation value* of  $a$ .) Try to find  $a_0$  and  $\lim_{t \rightarrow \infty} s(t)$  in the case where  $a > a_0$ . HINT: See Exercise 14.
14. An object of mass  $m$  falls in a medium that exerts a resistive force  $f = f(s)$ , where  $s = |v|$  is the speed of the object. Assume that  $f(0) = 0$  and  $f$  is strictly increasing and differentiable on  $(0, \infty)$ .
- Write a differential equation for the speed  $s = s(t)$  of the object. Take it as given that all solutions of this equation with  $s(0) \geq 0$  are defined for all  $t > 0$  (which makes good sense on physical grounds).
  - Show that if  $\lim_{s \rightarrow \infty} f(s) \leq mg$  then  $\lim_{t \rightarrow \infty} s(t) = \infty$ .
  - Show that if  $\lim_{s \rightarrow \infty} f(s) > mg$  then  $\lim_{t \rightarrow \infty} s(t) = s_T$  (terminal speed), where  $f(s_T) = mg$ . HINT: Use Theorem 2.3.1.
15. A 100-g mass with initial velocity  $v_0 \leq 0$  falls in a medium that exerts a resistive force proportional to the fourth power of the speed. The resistance is .1 N if the speed is 3 m/s.
- Set up the initial value problem for the velocity  $v$  of the mass for  $t > 0$ .
  - Use Exercise 14(c) to determine the terminal velocity of the object.
  - C** To confirm your answer to (b), use one of the numerical methods studied in Chapter 3 to compute approximate solutions on  $[0, 1]$  (seconds) of the initial value problem of (a), with initial values  $v_0 = 0, -2, -4, \dots, -12$ . Present your results in graphical form similar to Figure 4.3.3.
16. A 64-lb object with initial velocity  $v_0 \leq 0$  falls through a dense fluid that exerts a resistive force proportional to the square root of the speed. The resistance is 64 lb if the speed is 16 ft/s.
- Set up the initial value problem for the velocity  $v$  of the mass for  $t > 0$ .
  - Use Exercise 14(c) to determine the terminal velocity of the object.
  - C** To confirm your answer to (b), use one of the numerical methods studied in Chapter 3 to compute approximate solutions on  $[0, 4]$  (seconds) of the initial value problem of (a), with initial values  $v_0 = 0, -5, -10, \dots, -30$ . Present your results in graphical form similar to Figure 4.3.3.

In Exercises 17-20, assume that the force due to gravity is given by Newton's law of gravitation. Take the upward direction to be positive.

17. A space probe is to be launched from a space station 200 miles above Earth. Determine its escape velocity in miles/s. Take Earth's radius to be 3960 miles.
18. A space vehicle is to be launched from the moon, which has a radius of about 1080 miles. The acceleration due to gravity at the surface of the moon is about  $5.31 \text{ ft/s}^2$ . Find the escape velocity in miles/s.
19. (a) Show that Eqn. (4.3.23) can be rewritten as

$$v^2 = \frac{h-y}{y+R} v_e^2 + v_0^2.$$

- (b) Show that if  $v_0 = \rho v_e$  with  $0 \leq \rho < 1$ , then the maximum altitude  $y_m$  attained by the space vehicle is

$$y_m = \frac{h + R\rho^2}{1 - \rho^2}.$$

- (c) By requiring that  $v(y_m) = 0$ , use Eqn. (4.3.22) to deduce that if  $v_0 < v_e$  then

$$|v| = v_e \left[ \frac{(1 - \rho^2)(y_m - y)}{y + R} \right]^{1/2},$$

where  $y_m$  and  $\rho$  are as defined in (b) and  $y \geq h$ .

- (d) Deduce from (c) that if  $v < v_e$ , the vehicle takes equal times to climb from  $y = h$  to  $y = y_m$  and to fall back from  $y = y_m$  to  $y = h$ .

20. In the situation considered in the discussion of escape velocity, show that  $\lim_{t \rightarrow \infty} y(t) = \infty$  if  $v(t) > 0$  for all  $t > 0$ .

HINT: Use a proof by contradiction. Assume that there's a number  $y_m$  such that  $y(t) \leq y_m$  for all  $t > 0$ . Deduce from this that there's positive number  $\alpha$  such that  $y''(t) \leq -\alpha$  for all  $t \geq 0$ . Show that this contradicts the assumption that  $v(t) > 0$  for all  $t > 0$ .

#### 4.4 AUTONOMOUS SECOND ORDER EQUATIONS

A second order differential equation that can be written as

$$y'' = F(y, y') \tag{4.4.1}$$

where  $F$  is independent of  $t$ , is said to be *autonomous*. An autonomous second order equation can be converted into a first order equation relating  $v = y'$  and  $y$ . If we let  $v = y'$ , (4.4.1) becomes

$$v' = F(y, v). \tag{4.4.2}$$

Since

$$v' = \frac{dv}{dt} = \frac{dv}{dy} \frac{dy}{dt} = v \frac{dv}{dy}, \tag{4.4.3}$$

(4.4.2) can be rewritten as

$$v \frac{dv}{dy} = F(y, v). \tag{4.4.4}$$

The integral curves of (4.4.4) can be plotted in the  $(y, v)$  plane, which is called the *Poincaré phase plane* of (4.4.1). If  $y$  is a solution of (4.4.1) then  $y = y(t), v = y'(t)$  is a parametric equation for an integral



curve of (4.4.4). We'll call these integral curves *trajectories* of (4.4.1), and we'll call (4.4.4) the *phase plane equivalent* of (4.4.1).

In this section we'll consider autonomous equations that can be written as

$$y'' + q(y, y')y' + p(y) = 0. \quad (4.4.5)$$

Equations of this form often arise in applications of Newton's second law of motion. For example, suppose  $y$  is the displacement of a moving object with mass  $m$ . It's reasonable to think of two types of time-independent forces acting on the object. One type - such as gravity - depends only on position. We could write such a force as  $-mp(y)$ . The second type - such as atmospheric resistance or friction - may depend on position and velocity. (Forces that depend on velocity are called *damping* forces.) We write this force as  $-mq(y, y')y'$ , where  $q(y, y')$  is usually a positive function and we've put the factor  $y'$  outside to make it explicit that the force is in the direction opposing the motion. In this case Newton's, second law of motion leads to (4.4.5).

The phase plane equivalent of (4.4.5) is

$$v \frac{dv}{dy} + q(y, v)v + p(y) = 0. \quad (4.4.6)$$

Some statements that we'll be making about the properties of (4.4.5) and (4.4.6) are intuitively reasonable, but difficult to prove. Therefore our presentation in this section will be informal: we'll just say things without proof, all of which are true if we assume that  $p = p(y)$  is continuously differentiable for all  $y$  and  $q = q(y, v)$  is continuously differentiable for all  $(y, v)$ . We begin with the following statements:

- **Statement 1.** If  $y_0$  and  $v_0$  are arbitrary real numbers then (4.4.5) has a unique solution on  $(-\infty, \infty)$  such that  $y(0) = y_0$  and  $y'(0) = v_0$ .
- **Statement 2.** If  $y = y(t)$  is a solution of (4.4.5) and  $\tau$  is any constant then  $y_1 = y(t - \tau)$  is also a solution of (4.4.5), and  $y$  and  $y_1$  have the same trajectory.
- **Statement 3.** If two solutions  $y$  and  $y_1$  of (4.4.5) have the same trajectory then  $y_1(t) = y(t - \tau)$  for some constant  $\tau$ .
- **Statement 4.** Distinct trajectories of (4.4.5) can't intersect; that is, if two trajectories of (4.4.5) intersect, they are identical.
- **Statement 5.** If the trajectory of a solution of (4.4.5) is a closed curve then  $(y(t), v(t))$  traverses the trajectory in a finite time  $T$ , and the solution is periodic with period  $T$ ; that is,  $y(t + T) = y(t)$  for all  $t$  in  $(-\infty, \infty)$ .

If  $\bar{y}$  is a constant such that  $p(\bar{y}) = 0$  then  $y \equiv \bar{y}$  is a constant solution of (4.4.5). We say that  $\bar{y}$  is an *equilibrium* of (4.4.5) and  $(\bar{y}, 0)$  is a *critical point* of the phase plane equivalent equation (4.4.6). We say that the equilibrium and the critical point are *stable* if, for any given  $\epsilon > 0$  *no matter how small*, there's a  $\delta > 0$ , *sufficiently small*, such that if

$$\sqrt{(y_0 - \bar{y})^2 + v_0^2} < \delta$$

then the solution of the initial value problem

$$y'' + q(y, y')y' + p(y) = 0, \quad y(0) = y_0, \quad y'(0) = v_0$$

satisfies the inequality

$$\sqrt{(y(t) - \bar{y})^2 + (v(t))^2} < \epsilon$$

for all  $t > 0$ . Figure 4.4.1 illustrates the geometrical interpretation of this definition in the Poincaré phase plane: if  $(y_0, v_0)$  is in the smaller shaded circle (with radius  $\delta$ ), then  $(y(t), v(t))$  must be in the larger circle (with radius  $\epsilon$ ) for all  $t > 0$ .

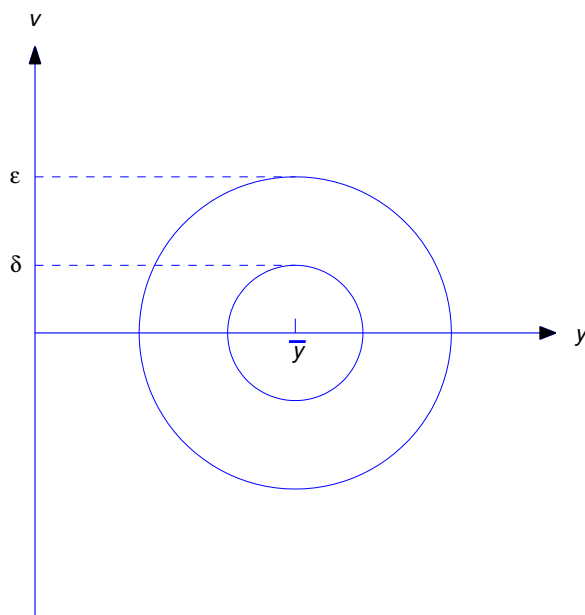

Figure 4.4.1 Stability: if  $(y_0, v_0)$  is in the smaller circle then  $(y(t), v(t))$  is in the larger circle for all  $t > 0$

If an equilibrium and the associated critical point are not stable, we say they are *unstable*. To see if you really understand what *stable* means, try to give a direct definition of *unstable* (Exercise 22). We'll illustrate both definitions in the following examples.

### The Undamped Case

We'll begin with the case where  $q \equiv 0$ , so (4.4.5) reduces to

$$y'' + p(y) = 0. \quad (4.4.7)$$

We say that this equation - as well as any physical situation that it may model - is *undamped*. The phase plane equivalent of (4.4.7) is the separable equation

$$v \frac{dv}{dy} + p(y) = 0.$$

Integrating this yields

$$\frac{v^2}{2} + P(y) = c, \quad (4.4.8)$$

where  $c$  is a constant of integration and  $P(y) = \int p(y) dy$  is an antiderivative of  $p$ .

If (4.4.7) is the equation of motion of an object of mass  $m$ , then  $mv^2/2$  is the kinetic energy and  $mP(y)$  is the potential energy of the object; thus, (4.4.8) says that the total energy of the object remains

constant, or is *conserved*. In particular, if a trajectory passes through a given point  $(y_0, v_0)$  then

$$c = \frac{v_0^2}{2} + P(y_0).$$

**Example 4.4.1** [*The Undamped Spring - Mass System*] Consider an object with mass  $m$  suspended from a spring and moving vertically. Let  $y$  be the displacement of the object from the position it occupies when suspended at rest from the spring (Figure 4.4.2).

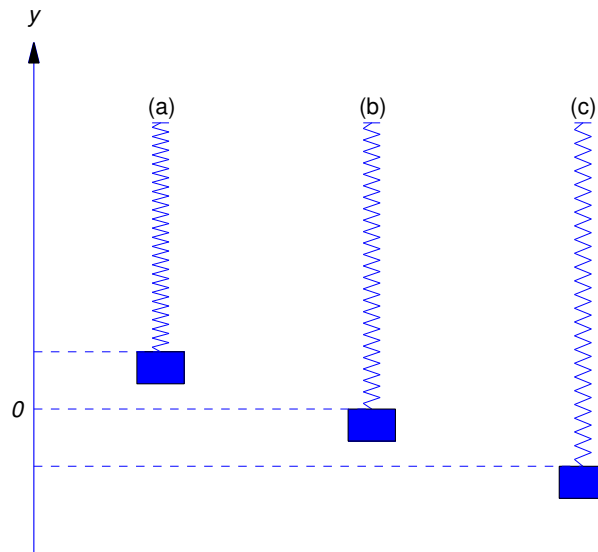

Figure 4.4.2 (a)  $y > 0$  (b)  $y = 0$  (c)  $y < 0$

Assume that if the length of the spring is changed by an amount  $\Delta L$  (positive or negative), then the spring exerts an opposing force with magnitude  $k|\Delta L|$ , where  $k$  is a positive constant. In Section 6.1 it will be shown that if the mass of the spring is negligible compared to  $m$  and no other forces act on the object then Newton's second law of motion implies that

$$my'' = -ky, \quad (4.4.9)$$

which can be written in the form (4.4.7) with  $p(y) = ky/m$ . This equation can be solved easily by a method that we'll study in Section 5.2, but that method isn't available here. Instead, we'll consider the phase plane equivalent of (4.4.9).

From (4.4.3), we can rewrite (4.4.9) as the separable equation

$$mv \frac{dv}{dy} = -ky.$$

Integrating this yields

$$\frac{mv^2}{2} = -\frac{ky^2}{2} + c,$$

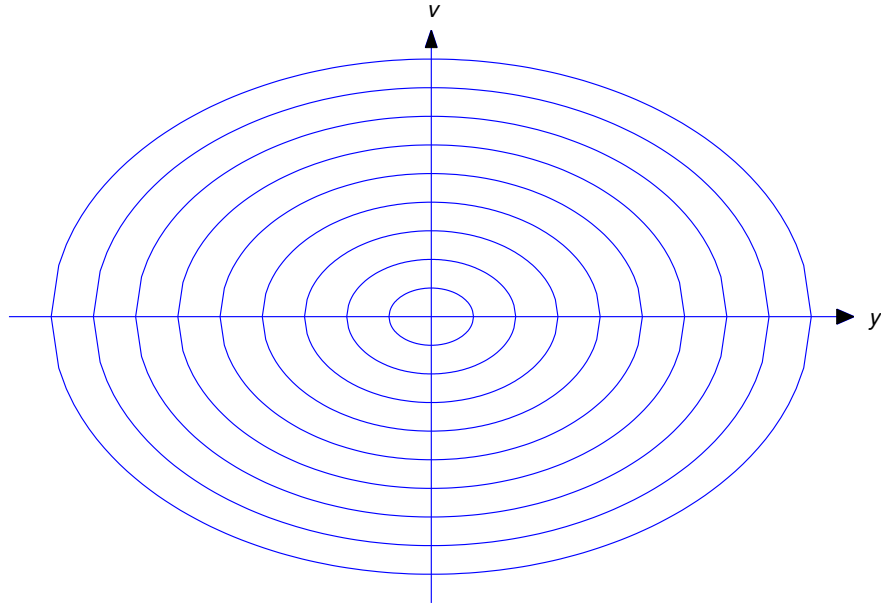
Figure 4.4.3 Trajectories of  $my'' + ky = 0$ 

which implies that

$$mv^2 + ky^2 = \rho \quad (4.4.10)$$

( $\rho = 2c$ ). This defines an ellipse in the Poincaré phase plane (Figure 4.4.3).

We can identify  $\rho$  by setting  $t = 0$  in (4.4.10); thus,  $\rho = mv_0^2 + ky_0^2$ , where  $y_0 = y(0)$  and  $v_0 = v(0)$ . To determine the maximum and minimum values of  $y$  we set  $v = 0$  in (4.4.10); thus,

$$y_{\max} = R \quad \text{and} \quad y_{\min} = -R, \quad \text{with } R = \sqrt{\frac{\rho}{k}}. \quad (4.4.11)$$

Equation (4.4.9) has exactly one equilibrium,  $\bar{y} = 0$ , and it's stable. You can see intuitively why this is so: if the object is displaced in either direction from equilibrium, the spring tries to bring it back.

In this case we can find  $y$  explicitly as a function of  $t$ . (Don't expect this to happen in more complicated problems!) If  $v > 0$  on an interval  $I$ , (4.4.10) implies that

$$\frac{dy}{dt} = v = \sqrt{\frac{\rho - ky^2}{m}}$$

on  $I$ . This is equivalent to

$$\frac{\sqrt{k}}{\sqrt{\rho - ky^2}} \frac{dy}{dt} = \omega_0, \quad \text{where } \omega_0 = \sqrt{\frac{k}{m}}. \quad (4.4.12)$$

Since

$$\int \frac{\sqrt{k} dy}{\sqrt{\rho - ky^2}} = \sin^{-1} \left( \sqrt{\frac{k}{\rho}} y \right) + c = \sin^{-1} \left( \frac{y}{R} \right) + c$$

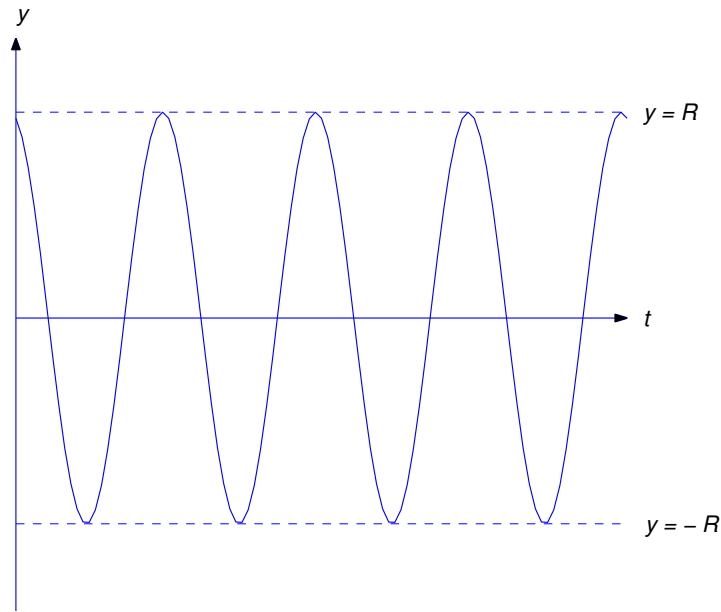
Figure 4.4.4  $y = R \sin(\omega_0 t + \phi)$ 

(see (4.4.11)), (4.4.12) implies that there's a constant  $\phi$  such that

$$\sin^{-1}\left(\frac{y}{R}\right) = \omega_0 t + \phi$$

or

$$y = R \sin(\omega_0 t + \phi)$$

for all  $t$  in  $I$ . Although we obtained this function by assuming that  $v > 0$ , you can easily verify that  $y$  satisfies (4.4.9) for all values of  $t$ . Thus, the displacement varies periodically between  $-R$  and  $R$ , with period  $T = 2\pi/\omega_0$  (Figure 4.4.4). (If you've taken a course in elementary mechanics you may recognize this as *simple harmonic motion*.)

**Example 4.4.2** [*The Undamped Pendulum*] Now we consider the motion of a pendulum with mass  $m$ , attached to the end of a weightless rod with length  $L$  that rotates on a frictionless axle (Figure 4.4.5). We assume that there's no air resistance.

Let  $y$  be the angle measured from the rest position (vertically downward) of the pendulum, as shown in Figure 4.4.5. Newton's second law of motion says that the product of  $m$  and the tangential acceleration equals the tangential component of the gravitational force; therefore, from Figure 4.4.5,

$$mLy'' = -mg \sin y,$$

or

$$y'' = -\frac{g}{L} \sin y. \quad (4.4.13)$$

Since  $\sin n\pi = 0$  if  $n$  is any integer, (4.4.13) has infinitely many equilibria  $\bar{y}_n = n\pi$ . If  $n$  is even, the mass is directly below the axle (Figure 4.4.6 (a)) and gravity opposes any deviation from the equilibrium.

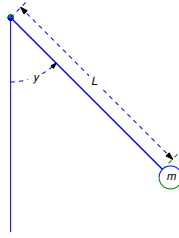

Figure 4.4.5 The undamped pendulum

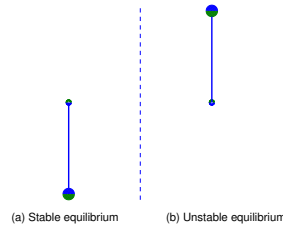

Figure 4.4.6 (a) Stable equilibrium (b) Unstable equilibrium

However, if  $n$  is odd, the mass is directly above the axle (Figure 4.4.6 (b)) and gravity increases any deviation from the equilibrium. Therefore we conclude on physical grounds that  $\bar{y}_{2m} = 2m\pi$  is stable and  $\bar{y}_{2m+1} = (2m + 1)\pi$  is unstable.

The phase plane equivalent of (4.4.13) is

$$v \frac{dv}{dy} = -\frac{g}{L} \sin y,$$

where  $v = y'$  is the angular velocity of the pendulum. Integrating this yields

$$\frac{v^2}{2} = \frac{g}{L} \cos y + c. \tag{4.4.14}$$

If  $v = v_0$  when  $y = 0$ , then

$$c = \frac{v_0^2}{2} - \frac{g}{L},$$

so (4.4.14) becomes

$$\frac{v^2}{2} = \frac{v_0^2}{2} - \frac{g}{L}(1 - \cos y) = \frac{v_0^2}{2} - \frac{2g}{L} \sin^2 \frac{y}{2},$$

which is equivalent to

$$v^2 = v_0^2 - v_c^2 \sin^2 \frac{y}{2}, \tag{4.4.15}$$

where

$$v_c = 2\sqrt{\frac{g}{L}}.$$

The curves defined by (4.4.15) are the trajectories of (4.4.13). They are periodic with period  $2\pi$  in  $y$ , which isn't surprising, since if  $y = y(t)$  is a solution of (4.4.13) then so is  $y_n = y(t) + 2n\pi$  for any integer  $n$ . Figure 4.4.7 shows trajectories over the interval  $[-\pi, \pi]$ . From (4.4.15), you can see that if  $|v_0| > v_c$  then  $v$  is nonzero for all  $t$ , which means that the object whirls in the same direction forever, as in Figure 4.4.8. The trajectories associated with this whirling motion are above the upper dashed curve and below the lower dashed curve in Figure 4.4.7. You can also see from (4.4.15) that if  $0 < |v_0| < v_c$ , then  $v = 0$  when  $y = \pm y_{\max}$ , where

$$y_{\max} = 2 \sin^{-1}(|v_0|/v_c).$$

In this case the pendulum oscillates periodically between  $-y_{\max}$  and  $y_{\max}$ , as shown in Figure 4.4.9. The trajectories associated with this kind of motion are the ovals between the dashed curves in Figure 4.4.7. It can be shown (see Exercise 21 for a partial proof) that the period of the oscillation is

$$T = 8 \int_0^{\pi/2} \frac{d\theta}{\sqrt{v_c^2 - v_0^2 \sin^2 \theta}}. \quad (4.4.16)$$

Although this integral can't be evaluated in terms of familiar elementary functions, you can see that it's finite if  $|v_0| < v_c$ .

The dashed curves in Figure 4.4.7 contain four trajectories. The critical points  $(\pi, 0)$  and  $(-\pi, 0)$  are the trajectories of the unstable equilibrium solutions  $\bar{y} = \pm\pi$ . The upper dashed curve connecting (but not including) them is obtained from initial conditions of the form  $y(t_0) = 0$ ,  $v(t_0) = v_c$ . If  $y$  is any solution with this trajectory then

$$\lim_{t \rightarrow \infty} y(t) = \pi \quad \text{and} \quad \lim_{t \rightarrow -\infty} y(t) = -\pi.$$

The lower dashed curve connecting (but not including) them is obtained from initial conditions of the form  $y(t_0) = 0$ ,  $v(t_0) = -v_c$ . If  $y$  is any solution with this trajectory then

$$\lim_{t \rightarrow \infty} y(t) = -\pi \quad \text{and} \quad \lim_{t \rightarrow -\infty} y(t) = \pi.$$

Consistent with this, the integral (4.4.16) diverges to  $\infty$  if  $v_0 = \pm v_c$ . (Exercise 21).

Since the dashed curves separate trajectories of whirling solutions from trajectories of oscillating solutions, each of these curves is called a *separatrix*.

In general, if (4.4.7) has both stable and unstable equilibria then the separatrices are the curves given by (4.4.8) that pass through unstable critical points. Thus, if  $(\bar{y}, 0)$  is an unstable critical point, then

$$\frac{v^2}{2} + P(y) = P(\bar{y}) \quad (4.4.17)$$

defines a separatrix passing through  $(\bar{y}, 0)$ .

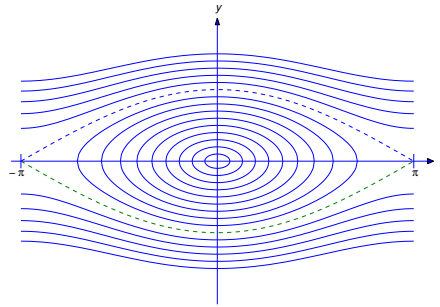

Figure 4.4.7 Trajectories of the undamped pendulum

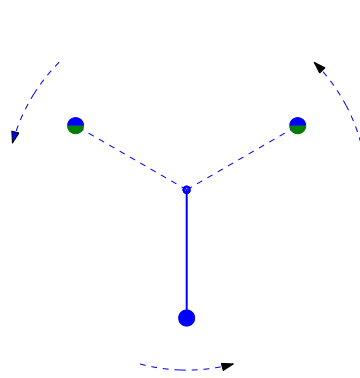

Figure 4.4.8 The whirling undamped pendulum

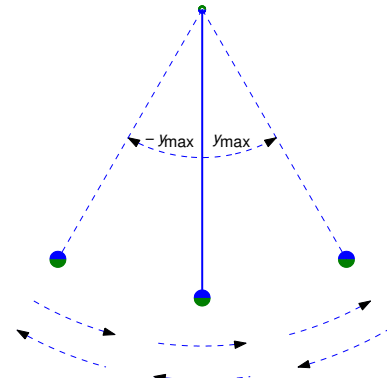

Figure 4.4.9 The oscillating undamped pendulum

**Stability and Instability Conditions for  $y'' + p(y) = 0$**

It can be shown (Exercise 23) that an equilibrium  $\bar{y}$  of an undamped equation

$$y'' + p(y) = 0 \tag{4.4.18}$$

is stable if there's an open interval  $(a, b)$  containing  $\bar{y}$  such that

$$p(y) < 0 \text{ if } a < y < \bar{y} \text{ and } p(y) > 0 \text{ if } \bar{y} < y < b. \tag{4.4.19}$$

If we regard  $p(y)$  as a force acting on a unit mass, (4.4.19) means that the force resists all sufficiently small displacements from  $\bar{y}$ .

We've already seen examples illustrating this principle. The equation (4.4.9) for the undamped spring-mass system is of the form (4.4.18) with  $p(y) = ky/m$ , which has only the stable equilibrium  $\bar{y} = 0$ . In this case (4.4.19) holds with  $a = -\infty$  and  $b = \infty$ . The equation (4.4.13) for the undamped pendulum is of the form (4.4.18) with  $p(y) = (g/L) \sin y$ . We've seen that  $\bar{y} = 2m\pi$  is a stable equilibrium if  $m$  is an integer. In this case

$$p(y) = \sin y < 0 \text{ if } (2m - 1)\pi < y < 2m\pi$$

and

$$p(y) > 0 \text{ if } 2m\pi < y < (2m + 1)\pi.$$



It can also be shown (Exercise 24) that  $\bar{y}$  is unstable if there's a  $b > \bar{y}$  such that

$$p(y) < 0 \text{ if } \bar{y} < y < b \quad (4.4.20)$$

or an  $a < \bar{y}$  such that

$$p(y) > 0 \text{ if } a < y < \bar{y}. \quad (4.4.21)$$

If we regard  $p(y)$  as a force acting on a unit mass, (4.4.20) means that the force tends to increase all sufficiently small positive displacements from  $\bar{y}$ , while (4.4.21) means that the force tends to increase the magnitude of all sufficiently small negative displacements from  $\bar{y}$ .

The undamped pendulum also illustrates this principle. We've seen that  $\bar{y} = (2m + 1)\pi$  is an unstable equilibrium if  $m$  is an integer. In this case

$$\sin y < 0 \text{ if } (2m + 1)\pi < y < (2m + 2)\pi,$$

so (4.4.20) holds with  $b = (2m + 2)\pi$ , and

$$\sin y > 0 \text{ if } 2m\pi < y < (2m + 1)\pi,$$

so (4.4.21) holds with  $a = 2m\pi$ .

**Example 4.4.3** The equation

$$y'' + y(y - 1) = 0 \quad (4.4.22)$$

is of the form (4.4.18) with  $p(y) = y(y - 1)$ . Therefore  $\bar{y} = 0$  and  $\bar{y} = 1$  are the equilibria of (4.4.22). Since

$$\begin{aligned} y(y - 1) &> 0 && \text{if } y < 0 \text{ or } y > 1, \\ &< 0 && \text{if } 0 < y < 1, \end{aligned}$$

$\bar{y} = 0$  is unstable and  $\bar{y} = 1$  is stable.

The phase plane equivalent of (4.4.22) is the separable equation

$$v \frac{dv}{dy} + y(y - 1) = 0.$$

Integrating yields

$$\frac{v^2}{2} + \frac{y^3}{3} - \frac{y^2}{2} = C,$$

which we rewrite as

$$v^2 + \frac{1}{3}y^2(2y - 3) = c \quad (4.4.23)$$

after renaming the constant of integration. These are the trajectories of (4.4.22). If  $y$  is any solution of (4.4.22), the point  $(y(t), v(t))$  moves along the trajectory of  $y$  in the direction of increasing  $y$  in the upper half plane ( $v = y' > 0$ ), or in the direction of decreasing  $y$  in the lower half plane ( $v = y' < 0$ ).

Figure 4.4.10 shows typical trajectories. The dashed curve through the critical point  $(0, 0)$ , obtained by setting  $c = 0$  in (4.4.23), separates the  $y$ - $v$  plane into regions that contain different kinds of trajectories; again, we call this curve a *separatrix*. Trajectories in the region bounded by the closed loop **(b)** are closed curves, so solutions associated with them are periodic. Solutions associated with other trajectories are not periodic. If  $y$  is any such solution with trajectory not on the separatrix, then

$$\begin{aligned} \lim_{t \rightarrow \infty} y(t) &= -\infty, & \lim_{t \rightarrow -\infty} y(t) &= -\infty, \\ \lim_{t \rightarrow \infty} v(t) &= -\infty, & \lim_{t \rightarrow -\infty} v(t) &= \infty. \end{aligned}$$

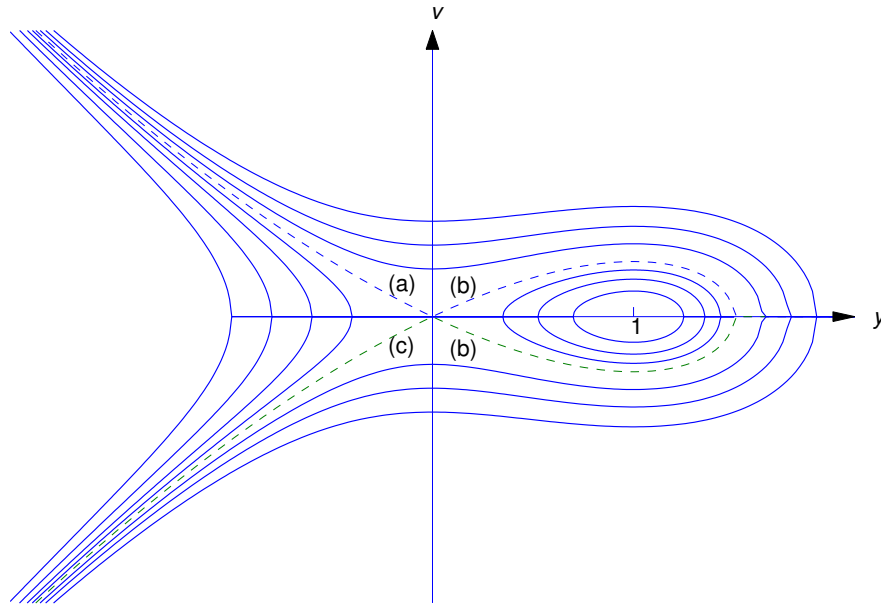

Figure 4.4.10 Trajectories of  $y'' + y(y - 1) = 0$

The separatrix contains four trajectories of (4.4.22). One is the point  $(0, 0)$ , the trajectory of the equilibrium  $\bar{y} = 0$ . Since distinct trajectories can't intersect, the segments of the separatrix marked **(a)**, **(b)**, and **(c)** – which don't include  $(0, 0)$  – are distinct trajectories, none of which can be traversed in finite time. Solutions with these trajectories have the following asymptotic behavior:

$$\begin{array}{ll}
 \lim_{t \rightarrow \infty} y(t) = 0, & \lim_{t \rightarrow -\infty} y(t) = -\infty, \\
 \lim_{t \rightarrow \infty} v(t) = 0, & \lim_{t \rightarrow -\infty} v(t) = \infty \quad \text{(on (a))} \\
 \lim_{t \rightarrow \infty} y(t) = 0, & \lim_{t \rightarrow -\infty} y(t) = 0, \\
 \lim_{t \rightarrow \infty} v(t) = 0, & \lim_{t \rightarrow -\infty} v(t) = 0 \quad \text{(on (b))} \\
 \lim_{t \rightarrow \infty} y(t) = -\infty, & \lim_{t \rightarrow -\infty} y(t) = 0, \\
 \lim_{t \rightarrow \infty} v(t) = -\infty, & \lim_{t \rightarrow -\infty} v(t) = 0 \quad \text{(on (c)).}
 \end{array}$$

### The Damped Case

The phase plane equivalent of the damped autonomous equation

$$y'' + q(y, y')y' + p(y) = 0 \tag{4.4.24}$$

is

$$v \frac{dv}{dy} + q(y, v)v + p(y) = 0.$$

This equation isn't separable, so we can't solve it for  $v$  in terms of  $y$ , as we did in the undamped case, and conservation of energy doesn't hold. (For example, energy expended in overcoming friction is lost.) However, we can study the qualitative behavior of its solutions by rewriting it as

$$\frac{dv}{dy} = -q(y, v) - \frac{p(y)}{v} \tag{4.4.25}$$

and considering the direction fields for this equation. In the following examples we'll also be showing computer generated trajectories of this equation, obtained by numerical methods. The exercises call for similar computations. The methods discussed in Chapter 3 are not suitable for this task, since  $p(y)/v$  in (4.4.25) is undefined on the  $y$  axis of the Poincaré phase plane. Therefore we're forced to apply numerical methods briefly discussed in Section 10.1 to the system

$$\begin{aligned}y' &= v \\v' &= -q(y, v)v - p(y),\end{aligned}$$

which is equivalent to (4.4.24) in the sense defined in Section 10.1. Fortunately, most differential equation software packages enable you to do this painlessly.

In the text we'll confine ourselves to the case where  $q$  is constant, so (4.4.24) and (4.4.25) reduce to

$$y'' + cy' + p(y) = 0 \tag{4.4.26}$$

and

$$\frac{dv}{dy} = -c - \frac{p(y)}{v}.$$

(We'll consider more general equations in the exercises.) The constant  $c$  is called the *damping constant*. In situations where (4.4.26) is the equation of motion of an object,  $c$  is positive; however, there are situations where  $c$  may be negative.

### The Damped Spring-Mass System

Earlier we considered the spring - mass system under the assumption that the only forces acting on the object were gravity and the spring's resistance to changes in its length. Now we'll assume that some mechanism (for example, friction in the spring or atmospheric resistance) opposes the motion of the object with a force proportional to its velocity. In Section 6.1 it will be shown that in this case Newton's second law of motion implies that

$$my'' + cy' + ky = 0, \tag{4.4.27}$$

where  $c > 0$  is the *damping constant*. Again, this equation can be solved easily by a method that we'll study in Section 5.2, but that method isn't available here. Instead, we'll consider its phase plane equivalent, which can be written in the form (4.4.25) as

$$\frac{dv}{dy} = -\frac{c}{m} - \frac{ky}{mv}. \tag{4.4.28}$$

(A minor note: the  $c$  in (4.4.26) actually corresponds to  $c/m$  in this equation.) Figure 4.4.11 shows a typical direction field for an equation of this form. Recalling that motion along a trajectory must be in the direction of increasing  $y$  in the upper half plane ( $v > 0$ ) and in the direction of decreasing  $y$  in the lower half plane ( $v < 0$ ), you can infer that all trajectories approach the origin in clockwise fashion. To confirm this, Figure 4.4.12 shows the same direction field with some trajectories filled in. All the trajectories shown there correspond to solutions of the initial value problem

$$my'' + cy' + ky = 0, \quad y(0) = y_0, \quad y'(0) = v_0,$$

where

$$mv_0^2 + ky_0^2 = \rho \quad (\text{a positive constant});$$

thus, if there were no damping ( $c = 0$ ), all the solutions would have the same dashed elliptic trajectory, shown in Figure 4.4.14.

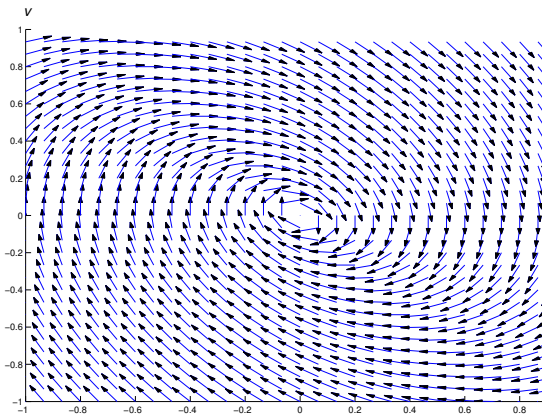

Figure 4.4.11 A typical direction field for  $my'' + cy' + ky = 0$  with  $0 < c < c_1$

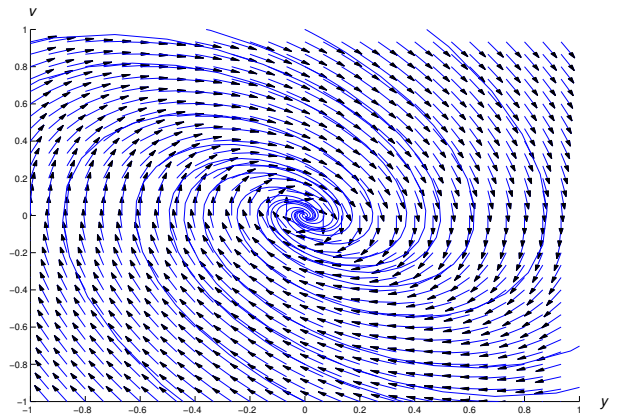

Figure 4.4.12 Figure 4.4.11 with some trajectories added

Solutions corresponding to the trajectories in Figure 4.4.12 cross the  $y$ -axis infinitely many times. The corresponding solutions are said to be *oscillatory* (Figure 4.4.13). It is shown in Section 6.2 that there's a number  $c_1$  such that if  $0 \leq c < c_1$  then all solutions of (4.4.27) are oscillatory, while if  $c \geq c_1$ , no solutions of (4.4.27) have this property. (In fact, no solution not identically zero can have more than two zeros in this case.) Figure 4.4.14 shows a direction field and some integral curves for (4.4.28) in this case.

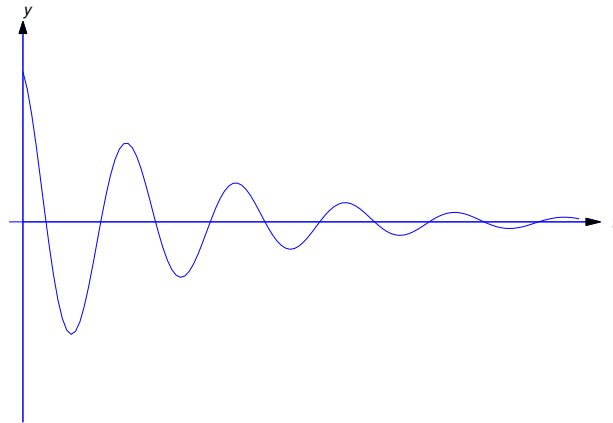

Figure 4.4.13 An oscillatory solution of  $my'' + cy' + ky = 0$

**Example 4.4.4 (The Damped Pendulum)** Now we return to the pendulum. If we assume that some mechanism (for example, friction in the axle or atmospheric resistance) opposes the motion of the pendulum with a force proportional to its angular velocity, Newton's second law of motion implies that

$$mLy'' = -cy' - mg \sin y, \quad (4.4.29)$$

where  $c > 0$  is the damping constant. (Again, a minor note: the  $c$  in (4.4.26) actually corresponds to

$c/mL$  in this equation.) To plot a direction field for (4.4.29) we write its phase plane equivalent as

$$\frac{dv}{dy} = -\frac{c}{mL} - \frac{g}{Lv} \sin y.$$

Figure 4.4.15 shows trajectories of four solutions of (4.4.29), all satisfying  $y(0) = 0$ . For each  $m = 0, 1, 2, 3$ , imparting the initial velocity  $v(0) = v_m$  causes the pendulum to make  $m$  complete revolutions and then settle into decaying oscillation about the stable equilibrium  $\bar{y} = 2m\pi$ .

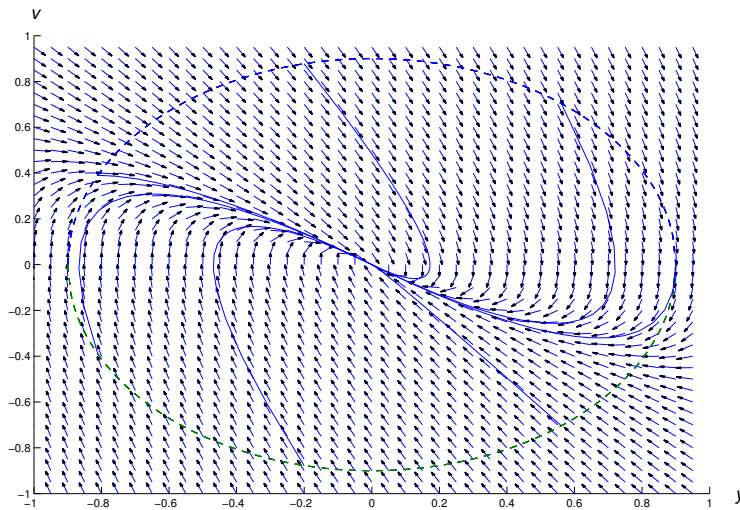

Figure 4.4.14 A typical direction field for  $my'' + cy' + ky = 0$  with  $c > c_1$

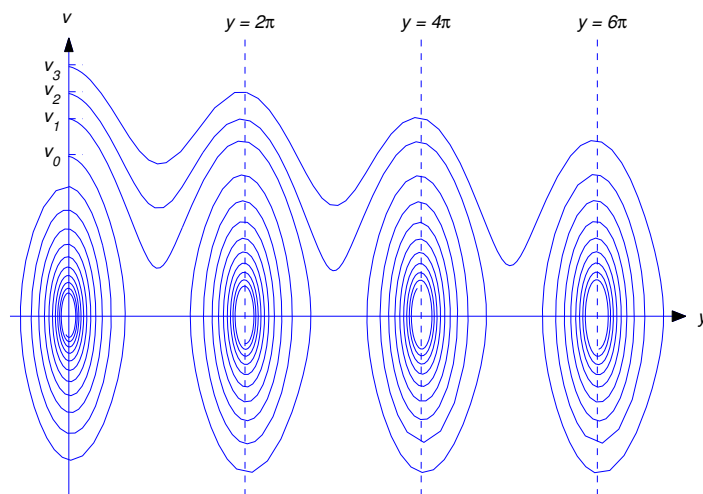

Figure 4.4.15 Four trajectories of the damped pendulum

### 4.4 Exercises

In Exercises 1–4 find the equations of the trajectories of the given undamped equation. Identify the equilibrium solutions, determine whether they are stable or unstable, and plot some trajectories. HINT: Use Eqn. (4.4.8) to obtain the equations of the trajectories.

1. C/G  $y'' + y^3 = 0$                       2. C/G  $y'' + y^2 = 0$   
 3. C/G  $y'' + y|y| = 0$                       4. C/G  $y'' + ye^{-y} = 0$

In Exercises 5–8 find the equations of the trajectories of the given undamped equation. Identify the equilibrium solutions, determine whether they are stable or unstable, and find the equations of the separatrices (that is, the curves through the unstable equilibria). Plot the separatrices and some trajectories in each of the regions of Poincaré plane determined by them. HINT: Use Eqn. (4.4.17) to determine the separatrices.

5. C/G  $y'' - y^3 + 4y = 0$                       6. C/G  $y'' + y^3 - 4y = 0$   
 7. C/G  $y'' + y(y^2 - 1)(y^2 - 4) = 0$     8. C/G  $y'' + y(y - 2)(y - 1)(y + 2) = 0$

In Exercises 9–12 plot some trajectories of the given equation for various values (positive, negative, zero) of the parameter  $a$ . Find the equilibria of the equation and classify them as stable or unstable. Explain why the phase plane plots corresponding to positive and negative values of  $a$  differ so markedly. Can you think of a reason why zero deserves to be called the *critical value* of  $a$ ?

9. L  $y'' + y^2 - a = 0$                       10. L  $y'' + y^3 - ay = 0$   
 11. L  $y'' - y^3 + ay = 0$                       12. L  $y'' + y - ay^3 = 0$

In Exercises 13–18 plot trajectories of the given equation for  $c = 0$  and small nonzero (positive and negative) values of  $c$  to observe the effects of damping.

13. L  $y'' + cy' + y^3 = 0$                       14. L  $y'' + cy' - y = 0$   
 15. L  $y'' + cy' + y^3 = 0$                       16. L  $y'' + cy' + y^2 = 0$   
 17. L  $y'' + cy' + y|y| = 0$                       18. L  $y'' + y(y - 1) + cy = 0$   
 19. L The *van der Pol equation*

$$y'' - \mu(1 - y^2)y' + y = 0, \tag{A}$$

where  $\mu$  is a positive constant and  $y$  is electrical current (Section 6.3), arises in the study of an electrical circuit whose resistive properties depend upon the current. The damping term  $-\mu(1 - y^2)y'$  works to reduce  $|y|$  if  $|y| < 1$  or to increase  $|y|$  if  $|y| > 1$ . It can be shown that van der Pol's equation has exactly one closed trajectory, which is called a *limit cycle*. Trajectories

inside the limit cycle spiral outward to it, while trajectories outside the limit cycle spiral inward to it (Figure 4.4.16). Use your favorite differential equations software to verify this for  $\mu = .5, 1.1, 5, 2$ . Use a grid with  $-4 < y < 4$  and  $-4 < v < 4$ .

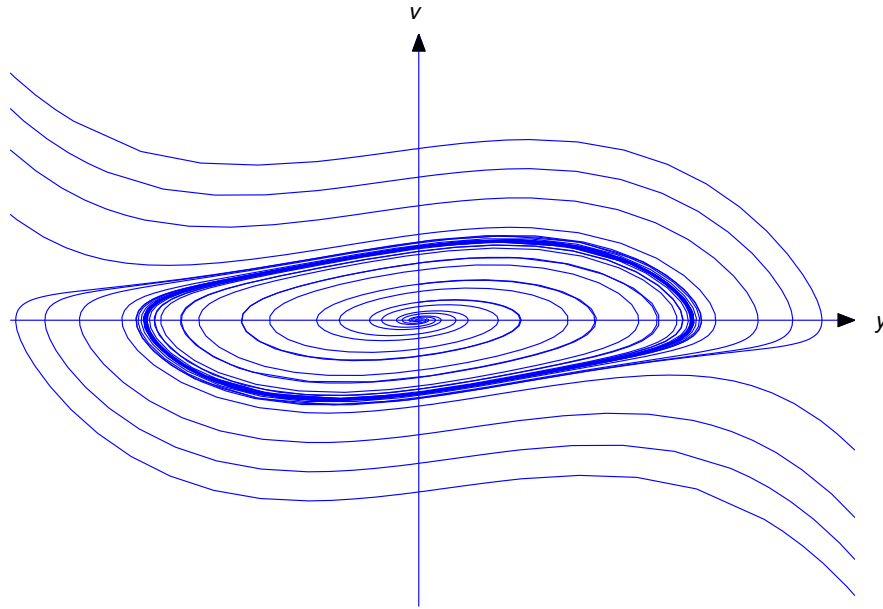

Figure 4.4.16 Trajectories of van der Pol's equation

20. L *Rayleigh's equation*,

$$y'' - \mu(1 - (y')^2/3)y' + y = 0$$

also has a limit cycle. Follow the directions of Exercise 19 for this equation.

21. In connection with Eqn (4.4.15), suppose  $y(0) = 0$  and  $y'(0) = v_0$ , where  $0 < v_0 < v_c$ .

- (a) Let  $T_1$  be the time required for  $y$  to increase from zero to  $y_{\max} = 2 \sin^{-1}(v_0/v_c)$ . Show that

$$\frac{dy}{dt} = \sqrt{v_0^2 - v_c^2 \sin^2 y/2}, \quad 0 \leq t < T_1. \tag{A}$$

- (b) Separate variables in (A) and show that

$$T_1 = \int_0^{y_{\max}} \frac{du}{\sqrt{v_0^2 - v_c^2 \sin^2 u/2}} \tag{B}$$

- (c) Substitute  $\sin u/2 = (v_0/v_c) \sin \theta$  in (B) to obtain

$$T_1 = 2 \int_0^{\pi/2} \frac{d\theta}{\sqrt{v_c^2 - v_0^2 \sin^2 \theta}}. \tag{C}$$

- (d) Conclude from symmetry that the time required for  $(y(t), v(t))$  to traverse the trajectory

$$v^2 = v_0^2 - v_c^2 \sin^2 y/2$$

is  $T = 4T_1$ , and that consequently  $y(t + T) = y(t)$  and  $v(t + T) = v(t)$ ; that is, the oscillation is periodic with period  $T$ .

- (e) Show that if  $v_0 = v_c$ , the integral in (C) is improper and diverges to  $\infty$ . Conclude from this that  $y(t) < \pi$  for all  $t$  and  $\lim_{t \rightarrow \infty} y(t) = \pi$ .
22. Give a direct definition of an unstable equilibrium of  $y'' + p(y) = 0$ .

23. Let  $p$  be continuous for all  $y$  and  $p(0) = 0$ . Suppose there's a positive number  $\rho$  such that  $p(y) > 0$  if  $0 < y \leq \rho$  and  $p(y) < 0$  if  $-\rho \leq y < 0$ . For  $0 < r \leq \rho$  let

$$\alpha(r) = \min \left\{ \int_0^r p(x) dx, \int_{-r}^0 |p(x)| dx \right\} \quad \text{and} \quad \beta(r) = \max \left\{ \int_0^r p(x) dx, \int_{-r}^0 |p(x)| dx \right\}.$$

Let  $y$  be the solution of the initial value problem

$$y'' + p(y) = 0, \quad y(0) = v_0, \quad y'(0) = v_0,$$

and define  $c(y_0, v_0) = v_0^2 + 2 \int_0^{y_0} p(x) dx$ .

- (a) Show that

$$0 < c(y_0, v_0) < v_0^2 + 2\beta(|y_0|) \quad \text{if} \quad 0 < |y_0| \leq \rho.$$

- (b) Show that

$$v^2 + 2 \int_0^y p(x) dx = c(y_0, v_0), \quad t > 0.$$

- (c) Conclude from (b) that if  $c(y_0, v_0) < 2\alpha(r)$  then  $|y| < r$ ,  $t > 0$ .

- (d) Given  $\epsilon > 0$ , let  $\delta > 0$  be chosen so that

$$\delta^2 + 2\beta(\delta) < \max \left\{ \epsilon^2/2, 2\alpha(\epsilon/\sqrt{2}) \right\}.$$

Show that if  $\sqrt{y_0^2 + v_0^2} < \delta$  then  $\sqrt{y^2 + v^2} < \epsilon$  for  $t > 0$ , which implies that  $\bar{y} = 0$  is a stable equilibrium of  $y'' + p(y) = 0$ .

- (e) Now let  $p$  be continuous for all  $y$  and  $p(\bar{y}) = 0$ , where  $\bar{y}$  is not necessarily zero. Suppose there's a positive number  $\rho$  such that  $p(y) > 0$  if  $\bar{y} < y \leq \bar{y} + \rho$  and  $p(y) < 0$  if  $\bar{y} - \rho \leq y < \bar{y}$ . Show that  $\bar{y}$  is a stable equilibrium of  $y'' + p(y) = 0$ .
24. Let  $p$  be continuous for all  $y$ .

- (a) Suppose  $p(0) = 0$  and there's a positive number  $\rho$  such that  $p(y) < 0$  if  $0 < y \leq \rho$ . Let  $\epsilon$  be any number such that  $0 < \epsilon < \rho$ . Show that if  $y$  is the solution of the initial value problem

$$y'' + p(y) = 0, \quad y(0) = y_0, \quad y'(0) = 0$$

with  $0 < y_0 < \epsilon$ , then  $y(t) \geq \epsilon$  for some  $t > 0$ . Conclude that  $\bar{y} = 0$  is an unstable equilibrium of  $y'' + p(y) = 0$ . HINT: Let  $k = \min_{y_0 \leq x \leq \epsilon} (-p(x))$ , which is positive. Show that if  $y(t) < \epsilon$  for  $0 \leq t < T$  then  $kT^2 < 2(\epsilon - y_0)$ .

- (b) Now let  $p(\bar{y}) = 0$ , where  $\bar{y}$  isn't necessarily zero. Suppose there's a positive number  $\rho$  such that  $p(y) < 0$  if  $\bar{y} < y \leq \bar{y} + \rho$ . Show that  $\bar{y}$  is an unstable equilibrium of  $y'' + p(y) = 0$ .
- (c) Modify your proofs of (a) and (b) to show that if there's a positive number  $\rho$  such that  $p(y) > 0$  if  $\bar{y} - \rho \leq y < \bar{y}$ , then  $\bar{y}$  is an unstable equilibrium of  $y'' + p(y) = 0$ .



## 4.5 APPLICATIONS TO CURVES

### One-Parameter Families of Curves

We begin with two examples of families of curves generated by varying a parameter over a set of real numbers.

**Example 4.5.1** For each value of the parameter  $c$ , the equation

$$y - cx^2 = 0 \quad (4.5.1)$$

defines a curve in the  $xy$ -plane. If  $c \neq 0$ , the curve is a parabola through the origin, opening upward if  $c > 0$  or downward if  $c < 0$ . If  $c = 0$ , the curve is the  $x$  axis (Figure 4.5.1).

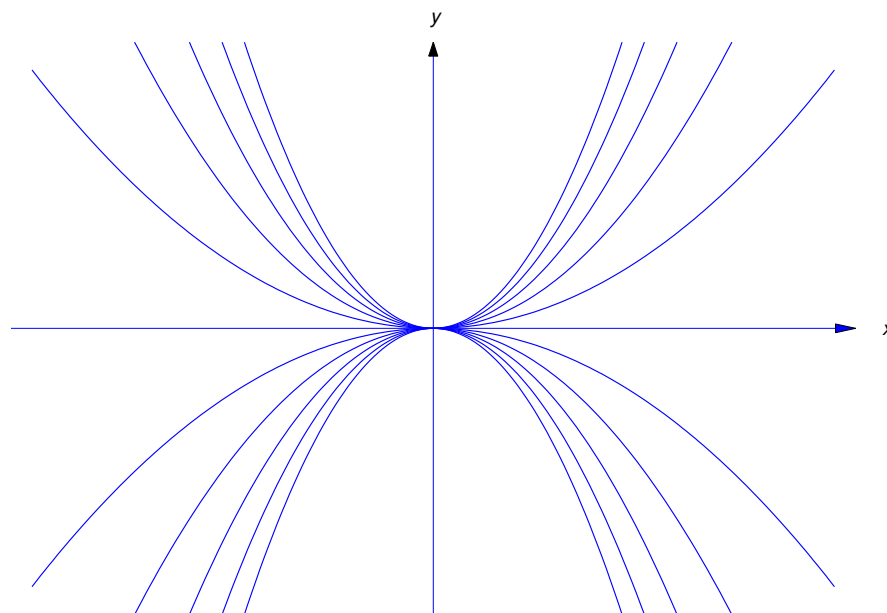

Figure 4.5.1 A family of curves defined by  $y - cx^2 = 0$

**Example 4.5.2** For each value of the parameter  $c$  the equation

$$y = x + c \quad (4.5.2)$$

defines a line with slope 1 (Figure 4.5.2).

**Definition 4.5.1** An equation that can be written in the form

$$H(x, y, c) = 0 \quad (4.5.3)$$

is said to define a *one-parameter family of curves* if, for each value of  $c$  in in some nonempty set of real numbers, the set of points  $(x, y)$  that satisfy (4.5.3) forms a curve in the  $xy$ -plane.

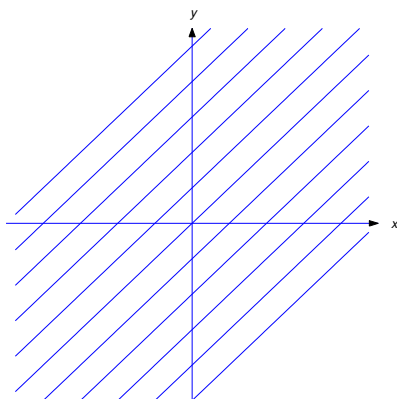
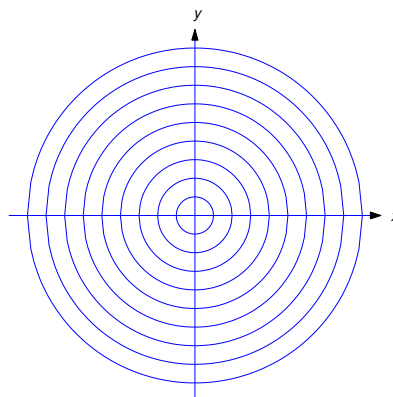
Figure 4.5.2 A family of lines defined by  $y = x + c$ Figure 4.5.3 A family of circles defined by  $x^2 + y^2 - c^2 = 0$ 

Equations (4.5.1) and (4.5.2) define one-parameter families of curves. (Although (4.5.2) isn't in the form (4.5.3), it can be written in this form as  $y - x - c = 0$ .)

**Example 4.5.3** If  $c > 0$ , the graph of the equation

$$x^2 + y^2 - c = 0 \quad (4.5.4)$$

is a circle with center at  $(0, 0)$  and radius  $\sqrt{c}$ . If  $c = 0$ , the graph is the single point  $(0, 0)$ . (We don't regard a single point as a curve.) If  $c < 0$ , the equation has no graph. Hence, (4.5.4) defines a one-parameter family of curves for positive values of  $c$ . This family consists of all circles centered at  $(0, 0)$  (Figure 4.5.3).

**Example 4.5.4** The equation

$$x^2 + y^2 + c^2 = 0$$

does not define a one-parameter family of curves, since no  $(x, y)$  satisfies the equation if  $c \neq 0$ , and only the single point  $(0, 0)$  satisfies it if  $c = 0$ . ■

Recall from Section 1.2 that the graph of a solution of a differential equation is called an *integral curve* of the equation. Solving a first order differential equation usually produces a one-parameter family of integral curves of the equation. Here we are interested in the converse problem: given a one-parameter family of curves, is there a first order differential equation for which every member of the family is an integral curve. This suggests the next definition.

**Definition 4.5.2** If every curve in a one-parameter family defined by the equation

$$H(x, y, c) = 0 \quad (4.5.5)$$

is an integral curve of the first order differential equation

$$F(x, y, y') = 0, \quad (4.5.6)$$

then (4.5.6) is said to be a *differential equation for the family*.

To find a differential equation for a one-parameter family we differentiate its defining equation (4.5.5) implicitly with respect to  $x$ , to obtain

$$H_x(x, y, c) + H_y(x, y, c)y' = 0. \quad (4.5.7)$$

If this equation doesn't, then it's a differential equation for the family. If it does contain  $c$ , it may be possible to obtain a differential equation for the family by eliminating  $c$  between (4.5.5) and (4.5.7).

**Example 4.5.5** Find a differential equation for the family of curves defined by

$$y = cx^2. \quad (4.5.8)$$

**Solution** Differentiating (4.5.8) with respect to  $x$  yields

$$y' = 2cx.$$

Therefore  $c = y'/2x$ , and substituting this into (4.5.8) yields

$$y = \frac{xy'}{2}$$

as a differential equation for the family of curves defined by (4.5.8). The graph of any function of the form  $y = cx^2$  is an integral curve of this equation. ■

The next example shows that members of a given family of curves may be obtained by joining integral curves for more than one differential equation.

**Example 4.5.6**

- (a) Try to find a differential equation for the family of lines tangent to the parabola  $y = x^2$ .
- (b) Find two tangent lines to the parabola  $y = x^2$  that pass through  $(2, 3)$ , and find the points of tangency.

**SOLUTION(a)** The equation of the line through a given point  $(x_0, y_0)$  with slope  $m$  is

$$y = y_0 + m(x - x_0). \quad (4.5.9)$$

If  $(x_0, y_0)$  is on the parabola, then  $y_0 = x_0^2$  and the slope of the tangent line through  $(x_0, x_0^2)$  is  $m = 2x_0$ ; hence, (4.5.9) becomes

$$y = x_0^2 + 2x_0(x - x_0),$$

or, equivalently,

$$y = -x_0^2 + 2x_0x. \quad (4.5.10)$$

Here  $x_0$  plays the role of the constant  $c$  in Definition 4.5.1; that is, varying  $x_0$  over  $(-\infty, \infty)$  produces the family of tangent lines to the parabola  $y = x^2$ .

Differentiating (4.5.10) with respect to  $x$  yields  $y' = 2x_0$ . We can express  $x_0$  in terms of  $x$  and  $y$  by rewriting (4.5.10) as

$$x_0^2 - 2x_0x + y = 0$$

and using the quadratic formula to obtain

$$x_0 = x \pm \sqrt{x^2 - y}. \quad (4.5.11)$$

We must choose the plus sign in (4.5.11) if  $x < x_0$  and the minus sign if  $x > x_0$ ; thus,

$$x_0 = \left( x + \sqrt{x^2 - y} \right) \text{ if } x < x_0$$

and

$$x_0 = \left( x - \sqrt{x^2 - y} \right) \text{ if } x > x_0.$$

Since  $y' = 2x_0$ , this implies that

$$y' = 2 \left( x + \sqrt{x^2 - y} \right), \text{ if } x < x_0 \quad (4.5.12)$$

and

$$y' = 2 \left( x - \sqrt{x^2 - y} \right), \text{ if } x > x_0. \quad (4.5.13)$$

Neither (4.5.12) nor (4.5.13) is a differential equation for the family of tangent lines to the parabola  $y = x^2$ . However, if each tangent line is regarded as consisting of two *tangent half lines* joined at the point of tangency, (4.5.12) is a differential equation for the family of tangent half lines on which  $x$  is less than the abscissa of the point of tangency (Figure 4.5.4(a)), while (4.5.13) is a differential equation for the family of tangent half lines on which  $x$  is greater than this abscissa (Figure 4.5.4(b)). The parabola  $y = x^2$  is also an integral curve of both (4.5.12) and (4.5.13).

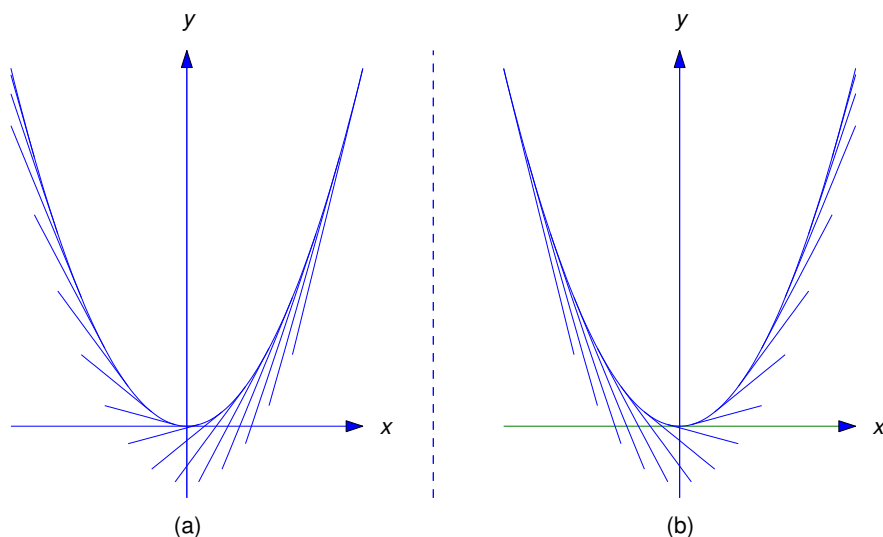

Figure 4.5.4

**SOLUTION(b)** From (4.5.10) the point  $(x, y) = (2, 3)$  is on the tangent line through  $(x_0, x_0^2)$  if and only if

$$3 = -x_0^2 + 4x_0,$$

which is equivalent to

$$x_0^2 - 4x_0 + 3 = (x_0 - 3)(x_0 - 1) = 0.$$

Letting  $x_0 = 3$  in (4.5.10) shows that  $(2, 3)$  is on the line

$$y = -9 + 6x,$$

which is tangent to the parabola at  $(x_0, x_0^2) = (3, 9)$ , as shown in Figure 4.5.5

Letting  $x_0 = 1$  in (4.5.10) shows that  $(2, 3)$  is on the line

$$y = -1 + 2x,$$

which is tangent to the parabola at  $(x_0, x_0^2) = (1, 1)$ , as shown in Figure 4.5.5.

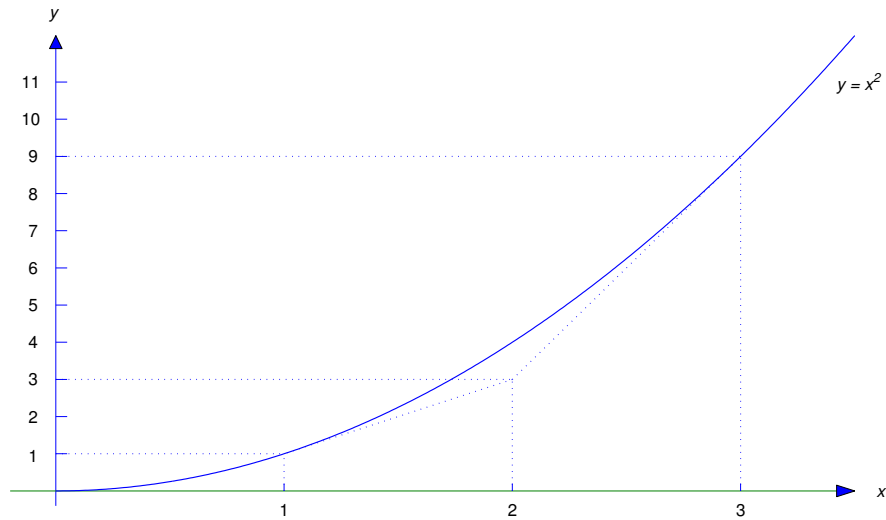

Figure 4.5.5

### Geometric Problems

We now consider some geometric problems that can be solved by means of differential equations.

**Example 4.5.7** Find curves  $y = y(x)$  such that every point  $(x_0, y(x_0))$  on the curve is the midpoint of the line segment with endpoints on the coordinate axes and tangent to the curve at  $(x_0, y(x_0))$  (Figure 4.5.6).

**Solution** The equation of the line tangent to the curve at  $P = (x_0, y(x_0))$  is

$$y = y(x_0) + y'(x_0)(x - x_0).$$

If we denote the  $x$  and  $y$  intercepts of the tangent line by  $x_I$  and  $y_I$  (Figure 4.5.6), then

$$0 = y(x_0) + y'(x_0)(x_I - x_0) \tag{4.5.14}$$

and

$$y_I = y(x_0) - y'(x_0)x_0. \tag{4.5.15}$$

From Figure 4.5.6,  $P$  is the midpoint of the line segment connecting  $(x_I, 0)$  and  $(0, y_I)$  if and only if  $x_I = 2x_0$  and  $y_I = 2y_0$ . Substituting the first of these conditions into (4.5.14) or the second into (4.5.15) yields

$$y(x_0) + y'(x_0)x_0 = 0.$$

Since  $x_0$  is arbitrary we drop the subscript and conclude that  $y = y(x)$  satisfies

$$y + xy' = 0,$$

which can be rewritten as

$$(xy)' = 0.$$

Integrating yields  $xy = c$ , or

$$y = \frac{c}{x}.$$

If  $c = 0$  this curve is the line  $y = 0$ , which does not satisfy the geometric requirements imposed by the problem; thus,  $c \neq 0$ , and the solutions define a family of hyperbolas (Figure 4.5.7).

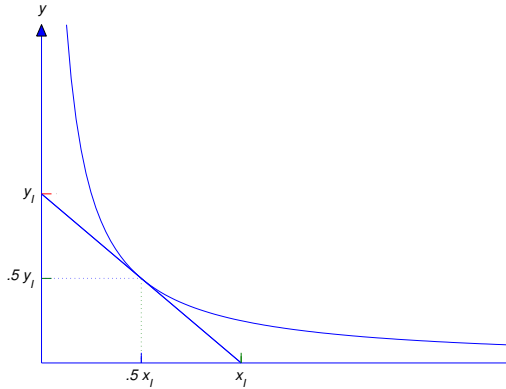

Figure 4.5.6

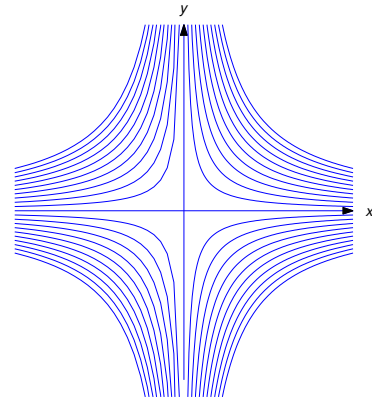

Figure 4.5.7

**Example 4.5.8** Find curves  $y = y(x)$  such that the tangent line to the curve at any point  $(x_0, y(x_0))$  intersects the  $x$ -axis at  $(x_0^2, 0)$ . Figure 4.5.8 illustrates the situation in the case where the curve is in the first quadrant and  $0 < x < 1$ .

**Solution** The equation of the line tangent to the curve at  $(x_0, y(x_0))$  is

$$y = y(x_0) + y'(x_0)(x - x_0).$$

Since  $(x_0^2, 0)$  is on the tangent line,

$$0 = y(x_0) + y'(x_0)(x_0^2 - x_0).$$

Since  $x_0$  is arbitrary we drop the subscript and conclude that  $y = y(x)$  satisfies

$$y + y'(x^2 - x) = 0.$$

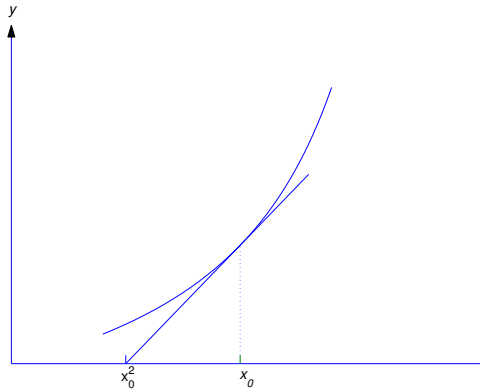

Figure 4.5.8

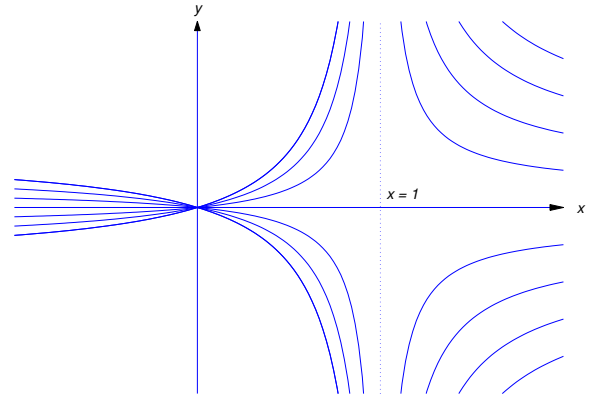

Figure 4.5.9

Therefore

$$\frac{y'}{y} = -\frac{1}{x^2 - x} = -\frac{1}{x(x - 1)} = \frac{1}{x} - \frac{1}{x - 1},$$

so

$$\ln |y| = \ln |x| - \ln |x - 1| + k = \ln \left| \frac{x}{x - 1} \right| + k,$$

and

$$y = \frac{cx}{x - 1}.$$

If  $c = 0$ , the graph of this function is the  $x$ -axis. If  $c \neq 0$ , it's a hyperbola with vertical asymptote  $x = 1$  and horizontal asymptote  $y = c$ . Figure 4.5.9 shows the graphs for  $c \neq 0$ .

### Orthogonal Trajectories

Two curves  $C_1$  and  $C_2$  are said to be *orthogonal* at a point of intersection  $(x_0, y_0)$  if they have perpendicular tangents at  $(x_0, y_0)$ . (Figure 4.5.10). A curve is said to be an *orthogonal trajectory* of a given family of curves if it's orthogonal to every curve in the family. For example, every line through the origin is an orthogonal trajectory of the family of circles centered at the origin. Conversely, any such circle is an orthogonal trajectory of the family of lines through the origin (Figure 4.5.11).

Orthogonal trajectories occur in many physical applications. For example, if  $u = u(x, y)$  is the temperature at a point  $(x, y)$ , the curves defined by

$$u(x, y) = c \tag{4.5.16}$$

are called *isothermal* curves. The orthogonal trajectories of this family are called *heat-flow* lines, because at any given point the direction of maximum heat flow is perpendicular to the isothermal through the point. If  $u$  represents the potential energy of an object moving under a force that depends upon  $(x, y)$ , the curves (4.5.16) are called *equipotentials*, and the orthogonal trajectories are called *lines of force*.

From analytic geometry we know that two nonvertical lines  $L_1$  and  $L_2$  with slopes  $m_1$  and  $m_2$ , respectively, are perpendicular if and only if  $m_2 = -1/m_1$ ; therefore, the integral curves of the differential equation

$$y' = -\frac{1}{f(x, y)}$$

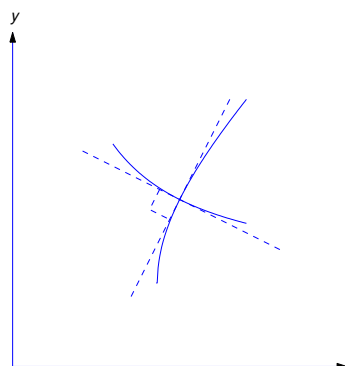

Figure 4.5.10 Curves orthogonal at a point of intersection

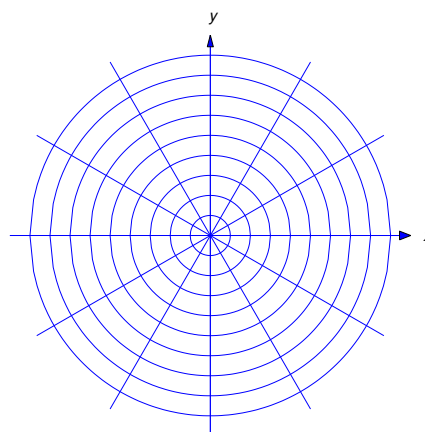

Figure 4.5.11 Orthogonal families of circles and lines

are orthogonal trajectories of the integral curves of the differential equation

$$y' = f(x, y),$$

because at any point  $(x_0, y_0)$  where curves from the two families intersect the slopes of the respective tangent lines are

$$m_1 = f(x_0, y_0) \quad \text{and} \quad m_2 = -\frac{1}{f(x_0, y_0)}.$$

This suggests a method for finding orthogonal trajectories of a family of integral curves of a first order equation.

### Finding Orthogonal Trajectories

**Step 1.** Find a differential equation

$$y' = f(x, y)$$

for the given family.

**Step 2.** Solve the differential equation

$$y' = -\frac{1}{f(x, y)}$$

to find the orthogonal trajectories.

**Example 4.5.9** Find the orthogonal trajectories of the family of circles

$$x^2 + y^2 = c^2 \quad (c > 0). \quad (4.5.17)$$

**Solution** To find a differential equation for the family of circles we differentiate (4.5.17) implicitly with respect to  $x$  to obtain

$$2x + 2yy' = 0,$$



or

$$y' = -\frac{x}{y}.$$

Therefore the integral curves of

$$y' = \frac{y}{x}$$

are orthogonal trajectories of the given family. We leave it to you to verify that the general solution of this equation is

$$y = kx,$$

where  $k$  is an arbitrary constant. This is the equation of a nonvertical line through  $(0, 0)$ . The  $y$  axis is also an orthogonal trajectory of the given family. Therefore every line through the origin is an orthogonal trajectory of the given family (4.5.17) (Figure 4.5.11). This is consistent with the theorem of plane geometry which states that a diameter of a circle and a tangent line to the circle at the end of the diameter are perpendicular.

**Example 4.5.10** Find the orthogonal trajectories of the family of hyperbolas

$$xy = c \quad (c \neq 0) \tag{4.5.18}$$

(Figure 4.5.7).

**Solution** Differentiating (4.5.18) implicitly with respect to  $x$  yields

$$y + xy' = 0,$$

or

$$y' = -\frac{y}{x};$$

thus, the integral curves of

$$y' = \frac{x}{y}$$

are orthogonal trajectories of the given family. Separating variables yields

$$y'y = x$$

and integrating yields

$$y^2 - x^2 = k,$$

which is the equation of a hyperbola if  $k \neq 0$ , or of the lines  $y = x$  and  $y = -x$  if  $k = 0$  (Figure 4.5.12).

**Example 4.5.11** Find the orthogonal trajectories of the family of circles defined by

$$(x - c)^2 + y^2 = c^2 \quad (c \neq 0). \tag{4.5.19}$$

These circles are centered on the  $x$ -axis and tangent to the  $y$ -axis (Figure 4.5.13(a)).

**Solution** Multiplying out the left side of (4.5.19) yields

$$x^2 - 2cx + y^2 = 0, \tag{4.5.20}$$

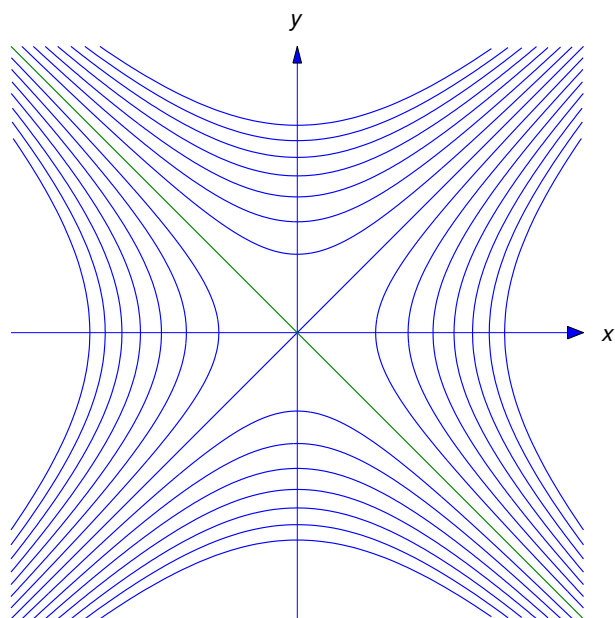
Figure 4.5.12 Orthogonal trajectories of the hyperbolas  $xy = c$ 

and differentiating this implicitly with respect to  $x$  yields

$$2(x - c) + 2yy' = 0. \quad (4.5.21)$$

From (4.5.20),

$$c = \frac{x^2 + y^2}{2x},$$

so

$$x - c = x - \frac{x^2 + y^2}{2x} = \frac{x^2 - y^2}{2x}.$$

Substituting this into (4.5.21) and solving for  $y'$  yields

$$y' = \frac{y^2 - x^2}{2xy}. \quad (4.5.22)$$

The curves defined by (4.5.19) are integral curves of (4.5.22), and the integral curves of

$$y' = \frac{2xy}{x^2 - y^2}$$

are orthogonal trajectories of the family (4.5.19). This is a homogeneous nonlinear equation, which we studied in Section 2.4. Substituting  $y = ux$  yields

$$u'x + u = \frac{2x(ux)}{x^2 - (ux)^2} = \frac{2u}{1 - u^2},$$

so

$$u'x = \frac{2u}{1 - u^2} - u = \frac{u(u^2 + 1)}{1 - u^2},$$

Separating variables yields

$$\frac{1-u^2}{u(u^2+1)}u' = \frac{1}{x},$$

or, equivalently,

$$\left[ \frac{1}{u} - \frac{2u}{u^2+1} \right] u' = \frac{1}{x}.$$

Therefore

$$\ln|u| - \ln(u^2+1) = \ln|x| + k.$$

By substituting  $u = y/x$ , we see that

$$\ln|y| - \ln|x| - \ln(x^2+y^2) + \ln(x^2) = \ln|x| + k,$$

which, since  $\ln(x^2) = 2 \ln|x|$ , is equivalent to

$$\ln|y| - \ln(x^2+y^2) = k,$$

or

$$|y| = e^k(x^2+y^2).$$

To see what these curves are we rewrite this equation as

$$x^2 + |y|^2 - e^{-k}|y| = 0$$

and complete the square to obtain

$$x^2 + (|y| - e^{-k}/2)^2 = (e^{-k}/2)^2.$$

This can be rewritten as

$$x^2 + (y - h)^2 = h^2,$$

where

$$h = \begin{cases} \frac{e^{-k}}{2} & \text{if } y \geq 0, \\ -\frac{e^{-k}}{2} & \text{if } y \leq 0. \end{cases}$$

Thus, the orthogonal trajectories are circles centered on the  $y$  axis and tangent to the  $x$  axis (Figure 4.5.13(b)). The circles for which  $h > 0$  are above the  $x$ -axis, while those for which  $h < 0$  are below.

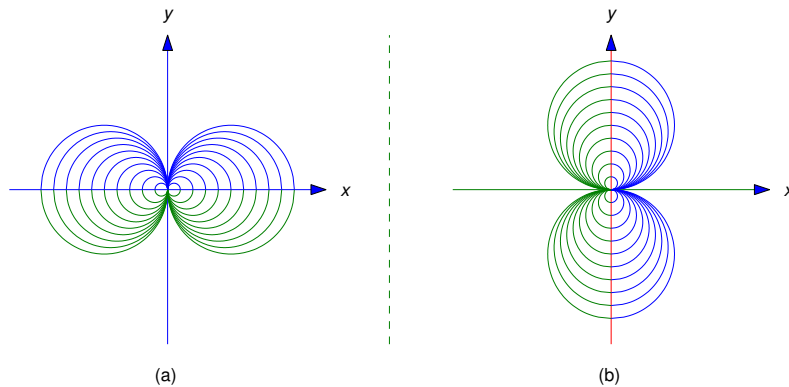

Figure 4.5.13 (a) The circles  $(x-c)^2 + y^2 = c^2$  (b) The circles  $x^2 + (y-h)^2 = h^2$

## 4.5 Exercises

In Exercises 1–8 find a first order differential equation for the given family of curves.

1.  $y(x^2 + y^2) = c$
2.  $e^{xy} = cy$
3.  $\ln |xy| = c(x^2 + y^2)$
4.  $y = x^{1/2} + cx$
5.  $y = e^{x^2} + ce^{-x^2}$
6.  $y = x^3 + \frac{c}{x}$
7.  $y = \sin x + ce^x$
8.  $y = e^x + c(1 + x^2)$
9. Show that the family of circles

$$(x - x_0)^2 + y^2 = 1, \quad -\infty < x_0 < \infty,$$

can be obtained by joining integral curves of two first order differential equations. More specifically, find differential equations for the families of semicircles

$$(x - x_0)^2 + y^2 = 1, \quad x_0 < x < x_0 + 1, \quad -\infty < x_0 < \infty,$$

$$(x - x_0)^2 + y^2 = 1, \quad x_0 - 1 < x < x_0, \quad -\infty < x_0 < \infty.$$

10. Suppose  $f$  and  $g$  are differentiable for all  $x$ . Find a differential equation for the family of functions  $y = f + cg$  ( $c$ =constant).

In Exercises 11–13 find a first order differential equation for the given family of curves.

11. Lines through a given point  $(x_0, y_0)$ .
12. Circles through  $(-1, 0)$  and  $(1, 0)$ .
13. Circles through  $(0, 0)$  and  $(0, 2)$ .
14. Use the method Example 4.5.6(a) to find the equations of lines through the given points tangent to the parabola  $y = x^2$ . Also, find the points of tangency.
  - (a)  $(5, 9)$
  - (b)  $(6, 11)$
  - (c)  $(-6, 20)$
  - (d)  $(-3, 5)$
15. (a) Show that the equation of the line tangent to the circle

$$x^2 + y^2 = 1 \tag{A}$$

at a point  $(x_0, y_0)$  on the circle is

$$y = \frac{1 - x_0x}{y_0} \quad \text{if } x_0 \neq \pm 1. \tag{B}$$

- (b) Show that if  $y'$  is the slope of a nonvertical tangent line to the circle (A) and  $(x, y)$  is a point on the tangent line then

$$(y')^2(x^2 - 1) - 2xyy' + y^2 - 1 = 0. \tag{C}$$

- (c) Show that the segment of the tangent line (B) on which  $(x - x_0)/y_0 > 0$  is an integral curve of the differential equation

$$y' = \frac{xy - \sqrt{x^2 + y^2 - 1}}{x^2 - 1}, \quad (\text{D})$$

while the segment on which  $(x - x_0)/y_0 < 0$  is an integral curve of the differential equation

$$y' = \frac{xy + \sqrt{x^2 + y^2 - 1}}{x^2 - 1}. \quad (\text{E})$$

*HINT: Use the quadratic formula to solve (C) for  $y'$ . Then substitute (B) for  $y$  and choose the  $\pm$  sign in the quadratic formula so that the resulting expression for  $y'$  reduces to the known slope  $y' = -x_0/y_0$ .*

- (d) Show that the upper and lower semicircles of (A) are also integral curves of (D) and (E).  
 (e) Find the equations of two lines through (5,5) tangent to the circle (A), and find the points of tangency.
16. (a) Show that the equation of the line tangent to the parabola

$$x = y^2 \quad (\text{A})$$

at a point  $(x_0, y_0) \neq (0, 0)$  on the parabola is

$$y = \frac{y_0}{2} + \frac{x}{2y_0}. \quad (\text{B})$$

- (b) Show that if  $y'$  is the slope of a nonvertical tangent line to the parabola (A) and  $(x, y)$  is a point on the tangent line then

$$4x^2(y')^2 - 4xyy' + x = 0. \quad (\text{C})$$

- (c) Show that the segment of the tangent line defined in (a) on which  $x > x_0$  is an integral curve of the differential equation

$$y' = \frac{y + \sqrt{y^2 - x}}{2x}, \quad (\text{D})$$

while the segment on which  $x < x_0$  is an integral curve of the differential equation

$$y' = \frac{y - \sqrt{y^2 - x}}{2x}, \quad (\text{E})$$

*HINT: Use the quadratic formula to solve (C) for  $y'$ . Then substitute (B) for  $y$  and choose the  $\pm$  sign in the quadratic formula so that the resulting expression for  $y'$  reduces to the known slope  $y' = \frac{1}{2y_0}$ .*

- (d) Show that the upper and lower halves of the parabola (A), given by  $y = \sqrt{x}$  and  $y = -\sqrt{x}$  for  $x > 0$ , are also integral curves of (D) and (E).
17. Use the results of Exercise 16 to find the equations of two lines tangent to the parabola  $x = y^2$  and passing through the given point. Also find the points of tangency.  
 (a)  $(-5, 2)$       (b)  $(-4, 0)$       (c)  $(7, 4)$       (d)  $(5, -3)$
18. Find a curve  $y = y(x)$  through (1,2) such that the tangent to the curve at any point  $(x_0, y(x_0))$  intersects the  $x$  axis at  $x_I = x_0/2$ .

19. Find all curves  $y = y(x)$  such that the tangent to the curve at any point  $(x_0, y(x_0))$  intersects the  $x$  axis at  $x_I = x_0^3$ .
20. Find all curves  $y = y(x)$  such that the tangent to the curve at any point passes through a given point  $(x_1, y_1)$ .
21. Find a curve  $y = y(x)$  through  $(1, -1)$  such that the tangent to the curve at any point  $(x_0, y(x_0))$  intersects the  $y$  axis at  $y_I = x_0^3$ .
22. Find all curves  $y = y(x)$  such that the tangent to the curve at any point  $(x_0, y(x_0))$  intersects the  $y$  axis at  $y_I = x_0$ .
23. Find a curve  $y = y(x)$  through  $(0, 2)$  such that the normal to the curve at any point  $(x_0, y(x_0))$  intersects the  $x$  axis at  $x_I = x_0 + 1$ .
24. Find a curve  $y = y(x)$  through  $(2, 1)$  such that the normal to the curve at any point  $(x_0, y(x_0))$  intersects the  $y$  axis at  $y_I = 2y(x_0)$ .

In Exercises 25–29 find the orthogonal trajectories of the given family of curves.

25.  $x^2 + 2y^2 = c^2$

26.  $x^2 + 4xy + y^2 = c$

27.  $y = ce^{2x}$

28.  $xye^{x^2} = c$

29.  $y = \frac{ce^x}{x}$

30. Find a curve through
- $(-1, 3)$
- orthogonal to every parabola of the form

$$y = 1 + cx^2$$

that it intersects. Which of these parabolas does the desired curve intersect?

31. Show that the orthogonal trajectories of

$$x^2 + 2axy + y^2 = c$$

satisfy

$$|y - x|^{a+1}|y + x|^{a-1} = k.$$

32. If lines  $L$  and  $L_1$  intersect at  $(x_0, y_0)$  and  $\alpha$  is the smallest angle through which  $L$  must be rotated counterclockwise about  $(x_0, y_0)$  to bring it into coincidence with  $L_1$ , we say that  $\alpha$  is the *angle from  $L$  to  $L_1$* ; thus,  $0 \leq \alpha < \pi$ . If  $L$  and  $L_1$  are tangents to curves  $C$  and  $C_1$ , respectively, that intersect at  $(x_0, y_0)$ , we say that  $C_1$  intersects  $C$  at the angle  $\alpha$ . Use the identity

$$\tan(A + B) = \frac{\tan A + \tan B}{1 - \tan A \tan B}$$

to show that if  $C$  and  $C_1$  are intersecting integral curves of

$$y' = f(x, y) \quad \text{and} \quad y' = \frac{f(x, y) + \tan \alpha}{1 - f(x, y) \tan \alpha} \quad \left(\alpha \neq \frac{\pi}{2}\right),$$

respectively, then  $C_1$  intersects  $C$  at the angle  $\alpha$ .

33. Use the result of Exercise 32 to find a family of curves that intersect every nonvertical line through the origin at the angle  $\alpha = \pi/4$ .
34. Use the result of Exercise 32 to find a family of curves that intersect every circle centered at the origin at a given angle  $\alpha \neq \pi/2$ .

# CHAPTER 5

## Linear Second Order Equations

IN THIS CHAPTER we study a particularly important class of second order equations. Because of their many applications in science and engineering, second order differential equations have historically been the most thoroughly studied class of differential equations. Research on the theory of second order differential equations continues to the present day. This chapter is devoted to second order equations that can be written in the form

$$P_0(x)y'' + P_1(x)y' + P_2(x)y = F(x).$$

Such equations are said to be *linear*. As in the case of first order linear equations, (A) is said to be *homogeneous* if  $F \equiv 0$ , or *nonhomogeneous* if  $F \not\equiv 0$ .

SECTION 5.1 is devoted to the theory of homogeneous linear equations.

SECTION 5.2 deals with homogeneous equations of the special form

$$ay'' + by' + cy = 0,$$

where  $a$ ,  $b$ , and  $c$  are constant ( $a \neq 0$ ). When you've completed this section you'll know everything there is to know about solving such equations.

SECTION 5.3 presents the theory of nonhomogeneous linear equations.

SECTIONS 5.4 AND 5.5 present the *method of undetermined coefficients*, which can be used to solve nonhomogeneous equations of the form

$$ay'' + by' + cy = F(x),$$

where  $a$ ,  $b$ , and  $c$  are constants and  $F$  has a special form that is still sufficiently general to occur in many applications. In this section we make extensive use of the idea of variation of parameters introduced in Chapter 2.

SECTION 5.6 deals with *reduction of order*, a technique based on the idea of variation of parameters, which enables us to find the general solution of a nonhomogeneous linear second order equation provided that we know one nontrivial (not identically zero) solution of the associated homogeneous equation.

SECTION 5.6 deals with the method traditionally called *variation of parameters*, which enables us to find the general solution of a nonhomogeneous linear second order equation provided that we know two nontrivial solutions (with nonconstant ratio) of the associated homogeneous equation.

## 5.1 HOMOGENEOUS LINEAR EQUATIONS

A second order differential equation is said to be *linear* if it can be written as

$$y'' + p(x)y' + q(x)y = f(x). \quad (5.1.1)$$

We call the function  $f$  on the right a *forcing function*, since in physical applications it's often related to a force acting on some system modeled by the differential equation. We say that (5.1.1) is *homogeneous* if  $f \equiv 0$  or *nonhomogeneous* if  $f \neq 0$ . Since these definitions are like the corresponding definitions in Section 2.1 for the linear first order equation

$$y' + p(x)y = f(x), \quad (5.1.2)$$

it's natural to expect similarities between methods of solving (5.1.1) and (5.1.2). However, solving (5.1.1) is more difficult than solving (5.1.2). For example, while Theorem 2.1.1 gives a formula for the general solution of (5.1.2) in the case where  $f \equiv 0$  and Theorem 2.1.2 gives a formula for the case where  $f \neq 0$ , there are no formulas for the general solution of (5.1.1) in either case. Therefore we must be content to solve linear second order equations of special forms.

In Section 2.1 we considered the homogeneous equation  $y' + p(x)y = 0$  first, and then used a nontrivial solution of this equation to find the general solution of the nonhomogeneous equation  $y' + p(x)y = f(x)$ . Although the progression from the homogeneous to the nonhomogeneous case isn't that simple for the linear second order equation, it's still necessary to solve the homogeneous equation

$$y'' + p(x)y' + q(x)y = 0 \quad (5.1.3)$$

in order to solve the nonhomogeneous equation (5.1.1). This section is devoted to (5.1.3).

The next theorem gives sufficient conditions for existence and uniqueness of solutions of initial value problems for (5.1.3). We omit the proof.

**Theorem 5.1.1** *Suppose  $p$  and  $q$  are continuous on an open interval  $(a, b)$ , let  $x_0$  be any point in  $(a, b)$ , and let  $k_0$  and  $k_1$  be arbitrary real numbers. Then the initial value problem*

$$y'' + p(x)y' + q(x)y = 0, \quad y(x_0) = k_0, \quad y'(x_0) = k_1$$

*has a unique solution on  $(a, b)$ .*

Since  $y \equiv 0$  is obviously a solution of (5.1.3) we call it the *trivial* solution. Any other solution is *nontrivial*. Under the assumptions of Theorem 5.1.1, the only solution of the initial value problem

$$y'' + p(x)y' + q(x)y = 0, \quad y(x_0) = 0, \quad y'(x_0) = 0$$

on  $(a, b)$  is the trivial solution (Exercise 24).

The next three examples illustrate concepts that we'll develop later in this section. You shouldn't be concerned with how to *find* the given solutions of the equations in these examples. This will be explained in later sections.

**Example 5.1.1** The coefficients of  $y'$  and  $y$  in

$$y'' - y = 0 \quad (5.1.4)$$

are the constant functions  $p \equiv 0$  and  $q \equiv -1$ , which are continuous on  $(-\infty, \infty)$ . Therefore Theorem 5.1.1 implies that every initial value problem for (5.1.4) has a unique solution on  $(-\infty, \infty)$ .



- (a) Verify that  $y_1 = e^x$  and  $y_2 = e^{-x}$  are solutions of (5.1.4) on  $(-\infty, \infty)$ .  
 (b) Verify that if  $c_1$  and  $c_2$  are arbitrary constants,  $y = c_1 e^x + c_2 e^{-x}$  is a solution of (5.1.4) on  $(-\infty, \infty)$ .  
 (c) Solve the initial value problem

$$y'' - y = 0, \quad y(0) = 1, \quad y'(0) = 3. \quad (5.1.5)$$

**SOLUTION(a)** If  $y_1 = e^x$  then  $y_1' = e^x$  and  $y_1'' = e^x = y_1$ , so  $y_1'' - y_1 = 0$ . If  $y_2 = e^{-x}$ , then  $y_2' = -e^{-x}$  and  $y_2'' = e^{-x} = y_2$ , so  $y_2'' - y_2 = 0$ .

**SOLUTION(b)** If

$$y = c_1 e^x + c_2 e^{-x} \quad (5.1.6)$$

then

$$y' = c_1 e^x - c_2 e^{-x} \quad (5.1.7)$$

and

$$y'' = c_1 e^x + c_2 e^{-x},$$

so

$$\begin{aligned} y'' - y &= (c_1 e^x + c_2 e^{-x}) - (c_1 e^x + c_2 e^{-x}) \\ &= c_1(e^x - e^x) + c_2(e^{-x} - e^{-x}) = 0 \end{aligned}$$

for all  $x$ . Therefore  $y = c_1 e^x + c_2 e^{-x}$  is a solution of (5.1.4) on  $(-\infty, \infty)$ .

**SOLUTION(c)** We can solve (5.1.5) by choosing  $c_1$  and  $c_2$  in (5.1.6) so that  $y(0) = 1$  and  $y'(0) = 3$ . Setting  $x = 0$  in (5.1.6) and (5.1.7) shows that this is equivalent to

$$\begin{aligned} c_1 + c_2 &= 1 \\ c_1 - c_2 &= 3. \end{aligned}$$

Solving these equations yields  $c_1 = 2$  and  $c_2 = -1$ . Therefore  $y = 2e^x - e^{-x}$  is the unique solution of (5.1.5) on  $(-\infty, \infty)$ .

**Example 5.1.2** Let  $\omega$  be a positive constant. The coefficients of  $y'$  and  $y$  in

$$y'' + \omega^2 y = 0 \quad (5.1.8)$$

are the constant functions  $p \equiv 0$  and  $q \equiv \omega^2$ , which are continuous on  $(-\infty, \infty)$ . Therefore Theorem 5.1.1 implies that every initial value problem for (5.1.8) has a unique solution on  $(-\infty, \infty)$ .

- (a) Verify that  $y_1 = \cos \omega x$  and  $y_2 = \sin \omega x$  are solutions of (5.1.8) on  $(-\infty, \infty)$ .  
 (b) Verify that if  $c_1$  and  $c_2$  are arbitrary constants then  $y = c_1 \cos \omega x + c_2 \sin \omega x$  is a solution of (5.1.8) on  $(-\infty, \infty)$ .  
 (c) Solve the initial value problem

$$y'' + \omega^2 y = 0, \quad y(0) = 1, \quad y'(0) = 3. \quad (5.1.9)$$

**SOLUTION(a)** If  $y_1 = \cos \omega x$  then  $y_1' = -\omega \sin \omega x$  and  $y_1'' = -\omega^2 \cos \omega x = -\omega^2 y_1$ , so  $y_1'' + \omega^2 y_1 = 0$ . If  $y_2 = \sin \omega x$  then,  $y_2' = \omega \cos \omega x$  and  $y_2'' = -\omega^2 \sin \omega x = -\omega^2 y_2$ , so  $y_2'' + \omega^2 y_2 = 0$ .

**SOLUTION(b)** If

$$y = c_1 \cos \omega x + c_2 \sin \omega x \quad (5.1.10)$$

then

$$y' = \omega(-c_1 \sin \omega x + c_2 \cos \omega x) \quad (5.1.11)$$

and

$$y'' = -\omega^2(c_1 \cos \omega x + c_2 \sin \omega x),$$

so

$$\begin{aligned} y'' + \omega^2 y &= -\omega^2(c_1 \cos \omega x + c_2 \sin \omega x) + \omega^2(c_1 \cos \omega x + c_2 \sin \omega x) \\ &= c_1 \omega^2(-\cos \omega x + \cos \omega x) + c_2 \omega^2(-\sin \omega x + \sin \omega x) = 0 \end{aligned}$$

for all  $x$ . Therefore  $y = c_1 \cos \omega x + c_2 \sin \omega x$  is a solution of (5.1.8) on  $(-\infty, \infty)$ .**SOLUTION(c)** To solve (5.1.9), we must choose  $c_1$  and  $c_2$  in (5.1.10) so that  $y(0) = 1$  and  $y'(0) = 3$ . Setting  $x = 0$  in (5.1.10) and (5.1.11) shows that  $c_1 = 1$  and  $c_2 = 3/\omega$ . Therefore

$$y = \cos \omega x + \frac{3}{\omega} \sin \omega x$$

is the unique solution of (5.1.9) on  $(-\infty, \infty)$ . ■Theorem 5.1.1 implies that if  $k_0$  and  $k_1$  are arbitrary real numbers then the initial value problem

$$P_0(x)y'' + P_1(x)y' + P_2(x)y = 0, \quad y(x_0) = k_0, \quad y'(x_0) = k_1 \quad (5.1.12)$$

has a unique solution on an interval  $(a, b)$  that contains  $x_0$ , provided that  $P_0, P_1$ , and  $P_2$  are continuous and  $P_0$  has no zeros on  $(a, b)$ . To see this, we rewrite the differential equation in (5.1.12) as

$$y'' + \frac{P_1(x)}{P_0(x)}y' + \frac{P_2(x)}{P_0(x)}y = 0$$

and apply Theorem 5.1.1 with  $p = P_1/P_0$  and  $q = P_2/P_0$ .**Example 5.1.3** The equation

$$x^2 y'' + xy' - 4y = 0 \quad (5.1.13)$$

has the form of the differential equation in (5.1.12), with  $P_0(x) = x^2$ ,  $P_1(x) = x$ , and  $P_2(x) = -4$ , which are all continuous on  $(-\infty, \infty)$ . However, since  $P_0(0) = 0$  we must consider solutions of (5.1.13) on  $(-\infty, 0)$  and  $(0, \infty)$ . Since  $P_0$  has no zeros on these intervals, Theorem 5.1.1 implies that the initial value problem

$$x^2 y'' + xy' - 4y = 0, \quad y(x_0) = k_0, \quad y'(x_0) = k_1$$

has a unique solution on  $(0, \infty)$  if  $x_0 > 0$ , or on  $(-\infty, 0)$  if  $x_0 < 0$ .

- (a) Verify that  $y_1 = x^2$  is a solution of (5.1.13) on  $(-\infty, \infty)$  and  $y_2 = 1/x^2$  is a solution of (5.1.13) on  $(-\infty, 0)$  and  $(0, \infty)$ .
- (b) Verify that if  $c_1$  and  $c_2$  are any constants then  $y = c_1 x^2 + c_2/x^2$  is a solution of (5.1.13) on  $(-\infty, 0)$  and  $(0, \infty)$ .
- (c) Solve the initial value problem

$$x^2 y'' + xy' - 4y = 0, \quad y(1) = 2, \quad y'(1) = 0. \quad (5.1.14)$$

(d) Solve the initial value problem

$$x^2 y'' + xy' - 4y = 0, \quad y(-1) = 2, \quad y'(-1) = 0. \quad (5.1.15)$$

**SOLUTION(a)** If  $y_1 = x^2$  then  $y'_1 = 2x$  and  $y''_1 = 2$ , so

$$x^2 y''_1 + xy'_1 - 4y_1 = x^2(2) + x(2x) - 4x^2 = 0$$

for  $x$  in  $(-\infty, \infty)$ . If  $y_2 = 1/x^2$ , then  $y'_2 = -2/x^3$  and  $y''_2 = 6/x^4$ , so

$$x^2 y''_2 + xy'_2 - 4y_2 = x^2 \left( \frac{6}{x^4} \right) - x \left( \frac{2}{x^3} \right) - \frac{4}{x^2} = 0$$

for  $x$  in  $(-\infty, 0)$  or  $(0, \infty)$ .

**SOLUTION(b)** If

$$y = c_1 x^2 + \frac{c_2}{x^2} \quad (5.1.16)$$

then

$$y' = 2c_1 x - \frac{2c_2}{x^3} \quad (5.1.17)$$

and

$$y'' = 2c_1 + \frac{6c_2}{x^4},$$

so

$$\begin{aligned} x^2 y'' + xy' - 4y &= x^2 \left( 2c_1 + \frac{6c_2}{x^4} \right) + x \left( 2c_1 x - \frac{2c_2}{x^3} \right) - 4 \left( c_1 x^2 + \frac{c_2}{x^2} \right) \\ &= c_1 (2x^2 + 2x^2 - 4x^2) + c_2 \left( \frac{6}{x^2} - \frac{2}{x^2} - \frac{4}{x^2} \right) \\ &= c_1 \cdot 0 + c_2 \cdot 0 = 0 \end{aligned}$$

for  $x$  in  $(-\infty, 0)$  or  $(0, \infty)$ .

**SOLUTION(c)** To solve (5.1.14), we choose  $c_1$  and  $c_2$  in (5.1.16) so that  $y(1) = 2$  and  $y'(1) = 0$ . Setting  $x = 1$  in (5.1.16) and (5.1.17) shows that this is equivalent to

$$\begin{aligned} c_1 + c_2 &= 2 \\ 2c_1 - 2c_2 &= 0. \end{aligned}$$

Solving these equations yields  $c_1 = 1$  and  $c_2 = 1$ . Therefore  $y = x^2 + 1/x^2$  is the unique solution of (5.1.14) on  $(0, \infty)$ .

**SOLUTION(d)** We can solve (5.1.15) by choosing  $c_1$  and  $c_2$  in (5.1.16) so that  $y(-1) = 2$  and  $y'(-1) = 0$ . Setting  $x = -1$  in (5.1.16) and (5.1.17) shows that this is equivalent to

$$\begin{aligned} c_1 + c_2 &= 2 \\ -2c_1 + 2c_2 &= 0. \end{aligned}$$

Solving these equations yields  $c_1 = 1$  and  $c_2 = 1$ . Therefore  $y = x^2 + 1/x^2$  is the unique solution of (5.1.15) on  $(-\infty, 0)$ . ■

Although the *formulas* for the solutions of (5.1.14) and (5.1.15) are both  $y = x^2 + 1/x^2$ , you should not conclude that these two initial value problems have the same solution. Remember that a solution of an initial value problem is defined *on an interval that contains the initial point*; therefore, the solution of (5.1.14) is  $y = x^2 + 1/x^2$  *on the interval*  $(0, \infty)$ , which contains the initial point  $x_0 = 1$ , while the solution of (5.1.15) is  $y = x^2 + 1/x^2$  *on the interval*  $(-\infty, 0)$ , which contains the initial point  $x_0 = -1$ .

### The General Solution of a Homogeneous Linear Second Order Equation

If  $y_1$  and  $y_2$  are defined on an interval  $(a, b)$  and  $c_1$  and  $c_2$  are constants, then

$$y = c_1 y_1 + c_2 y_2$$

is a *linear combination of  $y_1$  and  $y_2$* . For example,  $y = 2 \cos x + 7 \sin x$  is a linear combination of  $y_1 = \cos x$  and  $y_2 = \sin x$ , with  $c_1 = 2$  and  $c_2 = 7$ .

The next theorem states a fact that we've already verified in Examples 5.1.1, 5.1.2, and 5.1.3.

**Theorem 5.1.2** *If  $y_1$  and  $y_2$  are solutions of the homogeneous equation*

$$y'' + p(x)y' + q(x)y = 0 \tag{5.1.18}$$

*on  $(a, b)$ , then any linear combination*

$$y = c_1 y_1 + c_2 y_2 \tag{5.1.19}$$

*of  $y_1$  and  $y_2$  is also a solution of (5.1.18) on  $(a, b)$ .*

**Proof** If

$$y = c_1 y_1 + c_2 y_2$$

then

$$y' = c_1 y_1' + c_2 y_2' \quad \text{and} \quad y'' = c_1 y_1'' + c_2 y_2''.$$

Therefore

$$\begin{aligned} y'' + p(x)y' + q(x)y &= (c_1 y_1'' + c_2 y_2'') + p(x)(c_1 y_1' + c_2 y_2') + q(x)(c_1 y_1 + c_2 y_2) \\ &= c_1 (y_1'' + p(x)y_1' + q(x)y_1) + c_2 (y_2'' + p(x)y_2' + q(x)y_2) \\ &= c_1 \cdot 0 + c_2 \cdot 0 = 0, \end{aligned}$$

since  $y_1$  and  $y_2$  are solutions of (5.1.18). ■

We say that  $\{y_1, y_2\}$  is a *fundamental set of solutions of (5.1.18) on  $(a, b)$*  if every solution of (5.1.18) on  $(a, b)$  can be written as a linear combination of  $y_1$  and  $y_2$  as in (5.1.19). In this case we say that (5.1.19) is *general solution of (5.1.18) on  $(a, b)$* .

### Linear Independence

We need a way to determine whether a given set  $\{y_1, y_2\}$  of solutions of (5.1.18) is a fundamental set. The next definition will enable us to state necessary and sufficient conditions for this.

We say that two functions  $y_1$  and  $y_2$  defined on an interval  $(a, b)$  are *linearly independent on  $(a, b)$*  if neither is a constant multiple of the other on  $(a, b)$ . (In particular, this means that neither can be the trivial solution of (5.1.18), since, for example, if  $y_1 \equiv 0$  we could write  $y_1 = 0y_2$ .) We'll also say that the set  $\{y_1, y_2\}$  is *linearly independent on  $(a, b)$* .

**Theorem 5.1.3** *Suppose  $p$  and  $q$  are continuous on  $(a, b)$ . Then a set  $\{y_1, y_2\}$  of solutions of*

$$y'' + p(x)y' + q(x)y = 0 \tag{5.1.20}$$

*on  $(a, b)$  is a fundamental set if and only if  $\{y_1, y_2\}$  is linearly independent on  $(a, b)$ .*

We'll present the proof of Theorem 5.1.3 in steps worth regarding as theorems in their own right. However, let's first interpret Theorem 5.1.3 in terms of Examples 5.1.1, 5.1.2, and 5.1.3.

**Example 5.1.4**

- (a) Since  $e^x/e^{-x} = e^{2x}$  is nonconstant, Theorem 5.1.3 implies that  $y = c_1e^x + c_2e^{-x}$  is the general solution of  $y'' - y = 0$  on  $(-\infty, \infty)$ .
- (b) Since  $\cos \omega x / \sin \omega x = \cot \omega x$  is nonconstant, Theorem 5.1.3 implies that  $y = c_1 \cos \omega x + c_2 \sin \omega x$  is the general solution of  $y'' + \omega^2 y = 0$  on  $(-\infty, \infty)$ .
- (c) Since  $x^2/x^{-2} = x^4$  is nonconstant, Theorem 5.1.3 implies that  $y = c_1x^2 + c_2/x^2$  is the general solution of  $x^2y'' + xy' - 4y = 0$  on  $(-\infty, 0)$  and  $(0, \infty)$ .

**The Wronskian and Abel's Formula**

To motivate a result that we need in order to prove Theorem 5.1.3, let's see what is required to prove that  $\{y_1, y_2\}$  is a fundamental set of solutions of (5.1.20) on  $(a, b)$ . Let  $x_0$  be an arbitrary point in  $(a, b)$ , and suppose  $y$  is an arbitrary solution of (5.1.20) on  $(a, b)$ . Then  $y$  is the unique solution of the initial value problem

$$y'' + p(x)y' + q(x)y = 0, \quad y(x_0) = k_0, \quad y'(x_0) = k_1; \quad (5.1.21)$$

that is,  $k_0$  and  $k_1$  are the numbers obtained by evaluating  $y$  and  $y'$  at  $x_0$ . Moreover,  $k_0$  and  $k_1$  can be any real numbers, since Theorem 5.1.1 implies that (5.1.21) has a solution no matter how  $k_0$  and  $k_1$  are chosen. Therefore  $\{y_1, y_2\}$  is a fundamental set of solutions of (5.1.20) on  $(a, b)$  if and only if it's possible to write the solution of an arbitrary initial value problem (5.1.21) as  $y = c_1y_1 + c_2y_2$ . This is equivalent to requiring that the system

$$\begin{aligned} c_1y_1(x_0) + c_2y_2(x_0) &= k_0 \\ c_1y_1'(x_0) + c_2y_2'(x_0) &= k_1 \end{aligned} \quad (5.1.22)$$

has a solution  $(c_1, c_2)$  for every choice of  $(k_0, k_1)$ . Let's try to solve (5.1.22).

Multiplying the first equation in (5.1.22) by  $y_2'(x_0)$  and the second by  $y_2(x_0)$  yields

$$\begin{aligned} c_1y_1(x_0)y_2'(x_0) + c_2y_2(x_0)y_2'(x_0) &= y_2'(x_0)k_0 \\ c_1y_1'(x_0)y_2(x_0) + c_2y_2'(x_0)y_2(x_0) &= y_2(x_0)k_1, \end{aligned}$$

and subtracting the second equation here from the first yields

$$(y_1(x_0)y_2'(x_0) - y_1'(x_0)y_2(x_0))c_1 = y_2'(x_0)k_0 - y_2(x_0)k_1. \quad (5.1.23)$$

Multiplying the first equation in (5.1.22) by  $y_1'(x_0)$  and the second by  $y_1(x_0)$  yields

$$\begin{aligned} c_1y_1(x_0)y_1'(x_0) + c_2y_2(x_0)y_1'(x_0) &= y_1'(x_0)k_0 \\ c_1y_1'(x_0)y_1(x_0) + c_2y_2'(x_0)y_1(x_0) &= y_1(x_0)k_1, \end{aligned}$$

and subtracting the first equation here from the second yields

$$(y_1(x_0)y_2'(x_0) - y_1'(x_0)y_2(x_0))c_2 = y_1(x_0)k_1 - y_1'(x_0)k_0. \quad (5.1.24)$$

If

$$y_1(x_0)y_2'(x_0) - y_1'(x_0)y_2(x_0) = 0,$$

it's impossible to satisfy (5.1.23) and (5.1.24) (and therefore (5.1.22)) unless  $k_0$  and  $k_1$  happen to satisfy

$$\begin{aligned} y_1(x_0)k_1 - y_1'(x_0)k_0 &= 0 \\ y_2'(x_0)k_0 - y_2(x_0)k_1 &= 0. \end{aligned}$$

On the other hand, if

$$y_1(x_0)y_2'(x_0) - y_1'(x_0)y_2(x_0) \neq 0 \quad (5.1.25)$$

we can divide (5.1.23) and (5.1.24) through by the quantity on the left to obtain

$$\begin{aligned} c_1 &= \frac{y_2'(x_0)k_0 - y_2(x_0)k_1}{y_1(x_0)y_2'(x_0) - y_1'(x_0)y_2(x_0)} \\ c_2 &= \frac{y_1(x_0)k_1 - y_1'(x_0)k_0}{y_1(x_0)y_2'(x_0) - y_1'(x_0)y_2(x_0)}, \end{aligned} \quad (5.1.26)$$

no matter how  $k_0$  and  $k_1$  are chosen. This motivates us to consider conditions on  $y_1$  and  $y_2$  that imply (5.1.25).

**Theorem 5.1.4** *Suppose  $p$  and  $q$  are continuous on  $(a, b)$ , let  $y_1$  and  $y_2$  be solutions of*

$$y'' + p(x)y' + q(x)y = 0 \quad (5.1.27)$$

*on  $(a, b)$ , and define*

$$W = y_1y_2' - y_1'y_2. \quad (5.1.28)$$

*Let  $x_0$  be any point in  $(a, b)$ . Then*

$$W(x) = W(x_0)e^{-\int_{x_0}^x p(t) dt}, \quad a < x < b. \quad (5.1.29)$$

*Therefore either  $W$  has no zeros in  $(a, b)$  or  $W \equiv 0$  on  $(a, b)$ .*

**Proof** Differentiating (5.1.28) yields

$$W' = y_1'y_2' + y_1y_2'' - y_1'y_2' - y_1''y_2 = y_1y_2'' - y_1''y_2. \quad (5.1.30)$$

Since  $y_1$  and  $y_2$  both satisfy (5.1.27),

$$y_1'' = -py_1' - qy_1 \quad \text{and} \quad y_2'' = -py_2' - qy_2.$$

Substituting these into (5.1.30) yields

$$\begin{aligned} W' &= -y_1(py_2' + qy_2) + y_2(py_1' + qy_1) \\ &= -p(y_1y_2' - y_2y_1') - q(y_1y_2 - y_2y_1) \\ &= -p(y_1y_2' - y_2y_1') = -pW. \end{aligned}$$

Therefore  $W' + p(x)W = 0$ ; that is,  $W$  is the solution of the initial value problem

$$y' + p(x)y = 0, \quad y(x_0) = W(x_0).$$

We leave it to you to verify by separation of variables that this implies (5.1.29). If  $W(x_0) \neq 0$ , (5.1.29) implies that  $W$  has no zeros in  $(a, b)$ , since an exponential is never zero. On the other hand, if  $W(x_0) = 0$ , (5.1.29) implies that  $W(x) = 0$  for all  $x$  in  $(a, b)$ . ■

The function  $W$  defined in (5.1.28) is the *Wronskian of  $\{y_1, y_2\}$* . Formula (5.1.29) is *Abel's formula*.

The Wronskian of  $\{y_1, y_2\}$  is usually written as the determinant

$$W = \begin{vmatrix} y_1 & y_2 \\ y_1' & y_2' \end{vmatrix}.$$

The expressions in (5.1.26) for  $c_1$  and  $c_2$  can be written in terms of determinants as

$$c_1 = \frac{1}{W(x_0)} \begin{vmatrix} k_0 & y_2(x_0) \\ k_1 & y_2'(x_0) \end{vmatrix} \quad \text{and} \quad c_2 = \frac{1}{W(x_0)} \begin{vmatrix} y_1(x_0) & k_0 \\ y_1'(x_0) & k_1 \end{vmatrix}.$$

If you've taken linear algebra you may recognize this as *Cramer's rule*.

**Example 5.1.5** Verify Abel's formula for the following differential equations and the corresponding solutions, from Examples 5.1.1, 5.1.2, and 5.1.3:

- (a)  $y'' - y = 0$ ;  $y_1 = e^x$ ,  $y_2 = e^{-x}$   
 (b)  $y'' + \omega^2 y = 0$ ;  $y_1 = \cos \omega x$ ,  $y_2 = \sin \omega x$   
 (c)  $x^2 y'' + xy' - 4y = 0$ ;  $y_1 = x^2$ ,  $y_2 = 1/x^2$

**SOLUTION(a)** Since  $p \equiv 0$ , we can verify Abel's formula by showing that  $W$  is constant, which is true, since

$$W(x) = \begin{vmatrix} e^x & e^{-x} \\ e^x & -e^{-x} \end{vmatrix} = e^x(-e^{-x}) - e^x e^{-x} = -2$$

for all  $x$ .

**SOLUTION(b)** Again, since  $p \equiv 0$ , we can verify Abel's formula by showing that  $W$  is constant, which is true, since

$$\begin{aligned} W(x) &= \begin{vmatrix} \cos \omega x & \sin \omega x \\ -\omega \sin \omega x & \omega \cos \omega x \end{vmatrix} \\ &= \cos \omega x (\omega \cos \omega x) - (-\omega \sin \omega x) \sin \omega x \\ &= \omega (\cos^2 \omega x + \sin^2 \omega x) = \omega \end{aligned}$$

for all  $x$ .

**SOLUTION(c)** Computing the Wronskian of  $y_1 = x^2$  and  $y_2 = 1/x^2$  directly yields

$$W = \begin{vmatrix} x^2 & 1/x^2 \\ 2x & -2/x^3 \end{vmatrix} = x^2 \left( -\frac{2}{x^3} \right) - 2x \left( \frac{1}{x^2} \right) = -\frac{4}{x}. \quad (5.1.31)$$

To verify Abel's formula we rewrite the differential equation as

$$y'' + \frac{1}{x}y' - \frac{4}{x^2}y = 0$$

to see that  $p(x) = 1/x$ . If  $x_0$  and  $x$  are either both in  $(-\infty, 0)$  or both in  $(0, \infty)$  then

$$\int_{x_0}^x p(t) dt = \int_{x_0}^x \frac{dt}{t} = \ln \left( \frac{x}{x_0} \right),$$

so Abel's formula becomes

$$\begin{aligned} W(x) &= W(x_0)e^{-\ln(x/x_0)} = W(x_0)\frac{x_0}{x} \\ &= -\left(\frac{4}{x_0}\right)\left(\frac{x_0}{x}\right) \quad \text{from (5.1.31)} \\ &= -\frac{4}{x}, \end{aligned}$$

which is consistent with (5.1.31). ■

The next theorem will enable us to complete the proof of Theorem 5.1.3.

**Theorem 5.1.5** *Suppose  $p$  and  $q$  are continuous on an open interval  $(a, b)$ , let  $y_1$  and  $y_2$  be solutions of*

$$y'' + p(x)y' + q(x)y = 0 \quad (5.1.32)$$

*on  $(a, b)$ , and let  $W = y_1y_2' - y_1'y_2$ . Then  $y_1$  and  $y_2$  are linearly independent on  $(a, b)$  if and only if  $W$  has no zeros on  $(a, b)$ .*

**Proof** We first show that if  $W(x_0) = 0$  for some  $x_0$  in  $(a, b)$ , then  $y_1$  and  $y_2$  are linearly dependent on  $(a, b)$ . Let  $I$  be a subinterval of  $(a, b)$  on which  $y_1$  has no zeros. (If there's no such subinterval,  $y_1 \equiv 0$  on  $(a, b)$ , so  $y_1$  and  $y_2$  are linearly dependent, and we're finished with this part of the proof.) Then  $y_2/y_1$  is defined on  $I$ , and

$$\left(\frac{y_2}{y_1}\right)' = \frac{y_1y_2' - y_1'y_2}{y_1^2} = \frac{W}{y_1^2}. \quad (5.1.33)$$

However, if  $W(x_0) = 0$ , Theorem 5.1.4 implies that  $W \equiv 0$  on  $(a, b)$ . Therefore (5.1.33) implies that  $(y_2/y_1)' \equiv 0$ , so  $y_2/y_1 = c$  (constant) on  $I$ . This shows that  $y_2(x) = cy_1(x)$  for all  $x$  in  $I$ . However, we want to show that  $y_2 = cy_1(x)$  for all  $x$  in  $(a, b)$ . Let  $Y = y_2 - cy_1$ . Then  $Y$  is a solution of (5.1.32) on  $(a, b)$  such that  $Y \equiv 0$  on  $I$ , and therefore  $Y' \equiv 0$  on  $I$ . Consequently, if  $x_0$  is chosen arbitrarily in  $I$  then  $Y$  is a solution of the initial value problem

$$y'' + p(x)y' + q(x)y = 0, \quad y(x_0) = 0, \quad y'(x_0) = 0,$$

which implies that  $Y \equiv 0$  on  $(a, b)$ , by the paragraph following Theorem 5.1.1. (See also Exercise 24). Hence,  $y_2 - cy_1 \equiv 0$  on  $(a, b)$ , which implies that  $y_1$  and  $y_2$  are not linearly independent on  $(a, b)$ .

Now suppose  $W$  has no zeros on  $(a, b)$ . Then  $y_1$  can't be identically zero on  $(a, b)$  (why not?), and therefore there is a subinterval  $I$  of  $(a, b)$  on which  $y_1$  has no zeros. Since (5.1.33) implies that  $y_2/y_1$  is nonconstant on  $I$ ,  $y_2$  isn't a constant multiple of  $y_1$  on  $(a, b)$ . A similar argument shows that  $y_1$  isn't a constant multiple of  $y_2$  on  $(a, b)$ , since

$$\left(\frac{y_1}{y_2}\right)' = \frac{y_1'y_2 - y_1y_2'}{y_2^2} = -\frac{W}{y_2^2}$$

on any subinterval of  $(a, b)$  where  $y_2$  has no zeros. ■

We can now complete the proof of Theorem 5.1.3. From Theorem 5.1.5, two solutions  $y_1$  and  $y_2$  of (5.1.32) are linearly independent on  $(a, b)$  if and only if  $W$  has no zeros on  $(a, b)$ . From Theorem 5.1.4 and the motivating comments preceding it,  $\{y_1, y_2\}$  is a fundamental set of solutions of (5.1.32) if and only if  $W$  has no zeros on  $(a, b)$ . Therefore  $\{y_1, y_2\}$  is a fundamental set for (5.1.32) on  $(a, b)$  if and only if  $\{y_1, y_2\}$  is linearly independent on  $(a, b)$ . ■

The next theorem summarizes the relationships among the concepts discussed in this section.

**Theorem 5.1.6** *Suppose  $p$  and  $q$  are continuous on an open interval  $(a, b)$  and let  $y_1$  and  $y_2$  be solutions of*

$$y'' + p(x)y' + q(x)y = 0 \quad (5.1.34)$$

*on  $(a, b)$ . Then the following statements are equivalent; that is, they are either all true or all false.*

- (a) *The general solution of (5.1.34) on  $(a, b)$  is  $y = c_1y_1 + c_2y_2$ .*
- (b)  *$\{y_1, y_2\}$  is a fundamental set of solutions of (5.1.34) on  $(a, b)$ .*
- (c)  *$\{y_1, y_2\}$  is linearly independent on  $(a, b)$ .*



(d) The Wronskian of  $\{y_1, y_2\}$  is nonzero at some point in  $(a, b)$ .

(e) The Wronskian of  $\{y_1, y_2\}$  is nonzero at all points in  $(a, b)$ .

We can apply this theorem to an equation written as

$$P_0(x)y'' + P_1(x)y' + P_2(x)y = 0$$

on an interval  $(a, b)$  where  $P_0, P_1,$  and  $P_2$  are continuous and  $P_0$  has no zeros.

**Theorem 5.1.7** Suppose  $c$  is in  $(a, b)$  and  $\alpha$  and  $\beta$  are real numbers, not both zero. Under the assumptions of Theorem 5.1.7, suppose  $y_1$  and  $y_2$  are solutions of (5.1.34) such that

$$\alpha y_1(c) + \beta y_1'(c) = 0 \quad \text{and} \quad \alpha y_2(c) + \beta y_2'(c) = 0. \quad (5.1.35)$$

Then  $\{y_1, y_2\}$  isn't linearly independent on  $(a, b)$ .

**Proof** Since  $\alpha$  and  $\beta$  are not both zero, (5.1.35) implies that

$$\begin{vmatrix} y_1(c) & y_1'(c) \\ y_2(c) & y_2'(c) \end{vmatrix} = 0, \quad \text{so} \quad \begin{vmatrix} y_1(c) & y_2(c) \\ y_1'(c) & y_2'(c) \end{vmatrix} = 0$$

and Theorem 5.1.6 implies the stated conclusion.

## 5.1 Exercises

---

1. (a) Verify that  $y_1 = e^{2x}$  and  $y_2 = e^{5x}$  are solutions of

$$y'' - 7y' + 10y = 0 \quad (A)$$

on  $(-\infty, \infty)$ .

- (b) Verify that if  $c_1$  and  $c_2$  are arbitrary constants then  $y = c_1e^{2x} + c_2e^{5x}$  is a solution of (A) on  $(-\infty, \infty)$ .  
 (c) Solve the initial value problem

$$y'' - 7y' + 10y = 0, \quad y(0) = -1, \quad y'(0) = 1.$$

- (d) Solve the initial value problem

$$y'' - 7y' + 10y = 0, \quad y(0) = k_0, \quad y'(0) = k_1.$$

2. (a) Verify that  $y_1 = e^x \cos x$  and  $y_2 = e^x \sin x$  are solutions of

$$y'' - 2y' + 2y = 0 \quad (A)$$

on  $(-\infty, \infty)$ .

- (b) Verify that if  $c_1$  and  $c_2$  are arbitrary constants then  $y = c_1e^x \cos x + c_2e^x \sin x$  is a solution of (A) on  $(-\infty, \infty)$ .  
 (c) Solve the initial value problem

$$y'' - 2y' + 2y = 0, \quad y(0) = 3, \quad y'(0) = -2.$$

(d) Solve the initial value problem

$$y'' - 2y' + 2y = 0, \quad y(0) = k_0, \quad y'(0) = k_1.$$

3. (a) Verify that  $y_1 = e^x$  and  $y_2 = xe^x$  are solutions of

$$y'' - 2y' + y = 0 \tag{A}$$

on  $(-\infty, \infty)$ .

(b) Verify that if  $c_1$  and  $c_2$  are arbitrary constants then  $y = e^x(c_1 + c_2x)$  is a solution of (A) on  $(-\infty, \infty)$ .

(c) Solve the initial value problem

$$y'' - 2y' + y = 0, \quad y(0) = 7, \quad y'(0) = 4.$$

(d) Solve the initial value problem

$$y'' - 2y' + y = 0, \quad y(0) = k_0, \quad y'(0) = k_1.$$

4. (a) Verify that  $y_1 = 1/(x-1)$  and  $y_2 = 1/(x+1)$  are solutions of

$$(x^2 - 1)y'' + 4xy' + 2y = 0 \tag{A}$$

on  $(-\infty, -1)$ ,  $(-1, 1)$ , and  $(1, \infty)$ . What is the general solution of (A) on each of these intervals?

(b) Solve the initial value problem

$$(x^2 - 1)y'' + 4xy' + 2y = 0, \quad y(0) = -5, \quad y'(0) = 1.$$

What is the interval of validity of the solution?

(c) C/G Graph the solution of the initial value problem.

(d) Verify Abel's formula for  $y_1$  and  $y_2$ , with  $x_0 = 0$ .

5. Compute the Wronskians of the given sets of functions.

(a)  $\{1, e^x\}$

(b)  $\{e^x, e^x \sin x\}$

(c)  $\{x+1, x^2+2\}$

(d)  $\{x^{1/2}, x^{-1/3}\}$

(e)  $\left\{\frac{\sin x}{x}, \frac{\cos x}{x}\right\}$

(f)  $\{x \ln |x|, x^2 \ln |x|\}$

(g)  $\{e^x \cos \sqrt{x}, e^x \sin \sqrt{x}\}$

6. Find the Wronskian of a given set  $\{y_1, y_2\}$  of solutions of

$$y'' + 3(x^2 + 1)y' - 2y = 0,$$

given that  $W(\pi) = 0$ .

7. Find the Wronskian of a given set  $\{y_1, y_2\}$  of solutions of

$$(1 - x^2)y'' - 2xy' + \alpha(\alpha + 1)y = 0,$$

given that  $W(0) = 1$ . (This is *Legendre's equation*.)

8. Find the Wronskian of a given set  $\{y_1, y_2\}$  of solutions of

$$x^2y'' + xy' + (x^2 - \nu^2)y = 0,$$

given that  $W(1) = 1$ . (This is *Bessel's equation*.)

9. (This exercise shows that if you know one nontrivial solution of  $y'' + p(x)y' + q(x)y = 0$ , you can use Abel's formula to find another.)

Suppose  $p$  and  $q$  are continuous and  $y_1$  is a solution of

$$y'' + p(x)y' + q(x)y = 0 \quad (\text{A})$$

that has no zeros on  $(a, b)$ . Let  $P(x) = \int p(x) dx$  be any antiderivative of  $p$  on  $(a, b)$ .

- (a) Show that if  $K$  is an arbitrary nonzero constant and  $y_2$  satisfies

$$y_1y_2' - y_1'y_2 = Ke^{-P(x)} \quad (\text{B})$$

on  $(a, b)$ , then  $y_2$  also satisfies (A) on  $(a, b)$ , and  $\{y_1, y_2\}$  is a fundamental set of solutions on (A) on  $(a, b)$ .

- (b) Conclude from (a) that if  $y_2 = uy_1$  where  $u' = K\frac{e^{-P(x)}}{y_1^2(x)}$ , then  $\{y_1, y_2\}$  is a fundamental set of solutions of (A) on  $(a, b)$ .

In Exercises 10–23 use the method suggested by Exercise 9 to find a second solution  $y_2$  that isn't a constant multiple of the solution  $y_1$ . Choose  $K$  conveniently to simplify  $y_2$ .

10.  $y'' - 2y' - 3y = 0$ ;  $y_1 = e^{3x}$   
 11.  $y'' - 6y' + 9y = 0$ ;  $y_1 = e^{3x}$   
 12.  $y'' - 2ay' + a^2y = 0$  ( $a = \text{constant}$ );  $y_1 = e^{ax}$   
 13.  $x^2y'' + xy' - y = 0$ ;  $y_1 = x$   
 14.  $x^2y'' - xy' + y = 0$ ;  $y_1 = x$   
 15.  $x^2y'' - (2a - 1)xy' + a^2y = 0$  ( $a = \text{nonzero constant}$ );  $x > 0$ ;  $y_1 = x^a$   
 16.  $4x^2y'' - 4xy' + (3 - 16x^2)y = 0$ ;  $y_1 = x^{1/2}e^{2x}$   
 17.  $(x - 1)y'' - xy' + y = 0$ ;  $y_1 = e^x$   
 18.  $x^2y'' - 2xy' + (x^2 + 2)y = 0$ ;  $y_1 = x \cos x$   
 19.  $4x^2(\sin x)y'' - 4x(x \cos x + \sin x)y' + (2x \cos x + 3 \sin x)y = 0$ ;  $y_1 = x^{1/2}$   
 20.  $(3x - 1)y'' - (3x + 2)y' - (6x - 8)y = 0$ ;  $y_1 = e^{2x}$   
 21.  $(x^2 - 4)y'' + 4xy' + 2y = 0$ ;  $y_1 = \frac{1}{x - 2}$   
 22.  $(2x + 1)xy'' - 2(2x^2 - 1)y' - 4(x + 1)y = 0$ ;  $y_1 = \frac{1}{x}$   
 23.  $(x^2 - 2x)y'' + (2 - x^2)y' + (2x - 2)y = 0$ ;  $y_1 = e^x$   
 24. Suppose  $p$  and  $q$  are continuous on an open interval  $(a, b)$  and let  $x_0$  be in  $(a, b)$ . Use Theorem 5.1.1 to show that the only solution of the initial value problem

$$y'' + p(x)y' + q(x)y = 0, \quad y(x_0) = 0, \quad y'(x_0) = 0$$

on  $(a, b)$  is the trivial solution  $y \equiv 0$ .

25. Suppose  $P_0$ ,  $P_1$ , and  $P_2$  are continuous on  $(a, b)$  and let  $x_0$  be in  $(a, b)$ . Show that if either of the following statements is true then  $P_0(x) = 0$  for some  $x$  in  $(a, b)$ .

(a) The initial value problem

$$P_0(x)y'' + P_1(x)y' + P_2(x)y = 0, \quad y(x_0) = k_0, \quad y'(x_0) = k_1$$

has more than one solution on  $(a, b)$ .

(b) The initial value problem

$$P_0(x)y'' + P_1(x)y' + P_2(x)y = 0, \quad y(x_0) = 0, \quad y'(x_0) = 0$$

has a nontrivial solution on  $(a, b)$ .

26. Suppose  $p$  and  $q$  are continuous on  $(a, b)$  and  $y_1$  and  $y_2$  are solutions of

$$y'' + p(x)y' + q(x)y = 0 \tag{A}$$

on  $(a, b)$ . Let

$$z_1 = \alpha y_1 + \beta y_2 \quad \text{and} \quad z_2 = \gamma y_1 + \delta y_2,$$

where  $\alpha$ ,  $\beta$ ,  $\gamma$ , and  $\delta$  are constants. Show that if  $\{z_1, z_2\}$  is a fundamental set of solutions of (A) on  $(a, b)$  then so is  $\{y_1, y_2\}$ .

27. Suppose  $p$  and  $q$  are continuous on  $(a, b)$  and  $\{y_1, y_2\}$  is a fundamental set of solutions of

$$y'' + p(x)y' + q(x)y = 0 \tag{A}$$

on  $(a, b)$ . Let

$$z_1 = \alpha y_1 + \beta y_2 \quad \text{and} \quad z_2 = \gamma y_1 + \delta y_2,$$

where  $\alpha$ ,  $\beta$ ,  $\gamma$ , and  $\delta$  are constants. Show that  $\{z_1, z_2\}$  is a fundamental set of solutions of (A) on  $(a, b)$  if and only if  $\alpha\gamma - \beta\delta \neq 0$ .

28. Suppose  $y_1$  is differentiable on an interval  $(a, b)$  and  $y_2 = ky_1$ , where  $k$  is a constant. Show that the Wronskian of  $\{y_1, y_2\}$  is identically zero on  $(a, b)$ .

29. Let

$$y_1 = x^3 \quad \text{and} \quad y_2 = \begin{cases} x^3, & x \geq 0, \\ -x^3, & x < 0. \end{cases}$$

(a) Show that the Wronskian of  $\{y_1, y_2\}$  is defined and identically zero on  $(-\infty, \infty)$ .

(b) Suppose  $a < 0 < b$ . Show that  $\{y_1, y_2\}$  is linearly independent on  $(a, b)$ .

(c) Use Exercise 25(b) to show that these results don't contradict Theorem 5.1.5, because neither  $y_1$  nor  $y_2$  can be a solution of an equation

$$y'' + p(x)y' + q(x)y = 0$$

on  $(a, b)$  if  $p$  and  $q$  are continuous on  $(a, b)$ .

30. Suppose  $p$  and  $q$  are continuous on  $(a, b)$  and  $\{y_1, y_2\}$  is a set of solutions of

$$y'' + p(x)y' + q(x)y = 0$$

on  $(a, b)$  such that either  $y_1(x_0) = y_2(x_0) = 0$  or  $y_1'(x_0) = y_2'(x_0) = 0$  for some  $x_0$  in  $(a, b)$ . Show that  $\{y_1, y_2\}$  is linearly dependent on  $(a, b)$ .

31. Suppose  $p$  and  $q$  are continuous on  $(a, b)$  and  $\{y_1, y_2\}$  is a fundamental set of solutions of

$$y'' + p(x)y' + q(x)y = 0$$

on  $(a, b)$ . Show that if  $y_1(x_1) = y_1(x_2) = 0$ , where  $a < x_1 < x_2 < b$ , then  $y_2(x) = 0$  for some  $x$  in  $(x_1, x_2)$ . HINT: Show that if  $y_2$  has no zeros in  $(x_1, x_2)$ , then  $y_1/y_2$  is either strictly increasing or strictly decreasing on  $(x_1, x_2)$ , and deduce a contradiction.

32. Suppose  $p$  and  $q$  are continuous on  $(a, b)$  and every solution of

$$y'' + p(x)y' + q(x)y = 0 \tag{A}$$

on  $(a, b)$  can be written as a linear combination of the twice differentiable functions  $\{y_1, y_2\}$ . Use Theorem 5.1.1 to show that  $y_1$  and  $y_2$  are themselves solutions of (A) on  $(a, b)$ .

33. Suppose  $p_1, p_2, q_1$ , and  $q_2$  are continuous on  $(a, b)$  and the equations

$$y'' + p_1(x)y' + q_1(x)y = 0 \quad \text{and} \quad y'' + p_2(x)y' + q_2(x)y = 0$$

have the same solutions on  $(a, b)$ . Show that  $p_1 = p_2$  and  $q_1 = q_2$  on  $(a, b)$ . HINT: Use Abel's formula.

34. (For this exercise you have to know about  $3 \times 3$  determinants.) Show that if  $y_1$  and  $y_2$  are twice continuously differentiable on  $(a, b)$  and the Wronskian  $W$  of  $\{y_1, y_2\}$  has no zeros in  $(a, b)$  then the equation

$$\frac{1}{W} \begin{vmatrix} y & y_1 & y_2 \\ y' & y_1' & y_2' \\ y'' & y_1'' & y_2'' \end{vmatrix} = 0$$

can be written as

$$y'' + p(x)y' + q(x)y = 0, \tag{A}$$

where  $p$  and  $q$  are continuous on  $(a, b)$  and  $\{y_1, y_2\}$  is a fundamental set of solutions of (A) on  $(a, b)$ . HINT: Expand the determinant by cofactors of its first column.

35. Use the method suggested by Exercise 34 to find a linear homogeneous equation for which the given functions form a fundamental set of solutions on some interval.

(a)  $e^x \cos 2x, \quad e^x \sin 2x$

(b)  $x, \quad e^{2x}$

(c)  $x, \quad x \ln x$

(d)  $\cos(\ln x), \quad \sin(\ln x)$

(e)  $\cosh x, \quad \sinh x$

(f)  $x^2 - 1, \quad x^2 + 1$

36. Suppose  $p$  and  $q$  are continuous on  $(a, b)$  and  $\{y_1, y_2\}$  is a fundamental set of solutions of

$$y'' + p(x)y' + q(x)y = 0 \tag{A}$$

on  $(a, b)$ . Show that if  $y$  is a solution of (A) on  $(a, b)$ , there's exactly one way to choose  $c_1$  and  $c_2$  so that  $y = c_1y_1 + c_2y_2$  on  $(a, b)$ .

37. Suppose  $p$  and  $q$  are continuous on  $(a, b)$  and  $x_0$  is in  $(a, b)$ . Let  $y_1$  and  $y_2$  be the solutions of

$$y'' + p(x)y' + q(x)y = 0 \tag{A}$$

such that

$$y_1(x_0) = 1, \quad y_1'(x_0) = 0 \quad \text{and} \quad y_2(x_0) = 0, \quad y_2'(x_0) = 1.$$

(Theorem 5.1.1 implies that each of these initial value problems has a unique solution on  $(a, b)$ .)

- (a) Show that  $\{y_1, y_2\}$  is linearly independent on  $(a, b)$ .  
 (b) Show that an arbitrary solution  $y$  of (A) on  $(a, b)$  can be written as  $y = y(x_0)y_1 + y'(x_0)y_2$ .  
 (c) Express the solution of the initial value problem

$$y'' + p(x)y' + q(x)y = 0, \quad y(x_0) = k_0, \quad y'(x_0) = k_1$$

as a linear combination of  $y_1$  and  $y_2$ .

38. Find solutions  $y_1$  and  $y_2$  of the equation  $y'' = 0$  that satisfy the initial conditions

$$y_1(x_0) = 1, \quad y_1'(x_0) = 0 \quad \text{and} \quad y_2(x_0) = 0, \quad y_2'(x_0) = 1.$$

Then use Exercise 37 (c) to write the solution of the initial value problem

$$y'' = 0, \quad y(0) = k_0, \quad y'(0) = k_1$$

as a linear combination of  $y_1$  and  $y_2$ .

39. Let  $x_0$  be an arbitrary real number. Given (Example 5.1.1) that  $e^x$  and  $e^{-x}$  are solutions of  $y'' - y = 0$ , find solutions  $y_1$  and  $y_2$  of  $y'' - y = 0$  such that

$$y_1(x_0) = 1, \quad y_1'(x_0) = 0 \quad \text{and} \quad y_2(x_0) = 0, \quad y_2'(x_0) = 1.$$

Then use Exercise 37 (c) to write the solution of the initial value problem

$$y'' - y = 0, \quad y(x_0) = k_0, \quad y'(x_0) = k_1$$

as a linear combination of  $y_1$  and  $y_2$ .

40. Let  $x_0$  be an arbitrary real number. Given (Example 5.1.2) that  $\cos \omega x$  and  $\sin \omega x$  are solutions of  $y'' + \omega^2 y = 0$ , find solutions of  $y'' + \omega^2 y = 0$  such that

$$y_1(x_0) = 1, \quad y_1'(x_0) = 0 \quad \text{and} \quad y_2(x_0) = 0, \quad y_2'(x_0) = 1.$$

Then use Exercise 37 (c) to write the solution of the initial value problem

$$y'' + \omega^2 y = 0, \quad y(x_0) = k_0, \quad y'(x_0) = k_1$$

as a linear combination of  $y_1$  and  $y_2$ . Use the identities

$$\begin{aligned} \cos(A + B) &= \cos A \cos B - \sin A \sin B \\ \sin(A + B) &= \sin A \cos B + \cos A \sin B \end{aligned}$$

to simplify your expressions for  $y_1, y_2$ , and  $y$ .

41. Recall from Exercise 4 that  $1/(x - 1)$  and  $1/(x + 1)$  are solutions of

$$(x^2 - 1)y'' + 4xy' + 2y = 0 \tag{A}$$

on  $(-1, 1)$ . Find solutions of (A) such that

$$y_1(0) = 1, \quad y_1'(0) = 0 \quad \text{and} \quad y_2(0) = 0, \quad y_2'(0) = 1.$$

Then use Exercise 37 (c) to write the solution of initial value problem

$$(x^2 - 1)y'' + 4xy' + 2y = 0, \quad y(0) = k_0, \quad y'(0) = k_1$$

as a linear combination of  $y_1$  and  $y_2$ .

42. (a) Verify that  $y_1 = x^2$  and  $y_2 = x^3$  satisfy

$$x^2y'' - 4xy' + 6y = 0 \quad (\text{A})$$

on  $(-\infty, \infty)$  and that  $\{y_1, y_2\}$  is a fundamental set of solutions of (A) on  $(-\infty, 0)$  and  $(0, \infty)$ .

- (b) Let  $a_1, a_2, b_1,$  and  $b_2$  be constants. Show that

$$y = \begin{cases} a_1x^2 + a_2x^3, & x \geq 0, \\ b_1x^2 + b_2x^3, & x < 0 \end{cases}$$

is a solution of (A) on  $(-\infty, \infty)$  if and only if  $a_1 = b_1$ . From this, justify the statement that  $y$  is a solution of (A) on  $(-\infty, \infty)$  if and only if

$$y = \begin{cases} c_1x^2 + c_2x^3, & x \geq 0, \\ c_1x^2 + c_3x^3, & x < 0, \end{cases}$$

where  $c_1, c_2,$  and  $c_3$  are arbitrary constants.

- (c) For what values of  $k_0$  and  $k_1$  does the initial value problem

$$x^2y'' - 4xy' + 6y = 0, \quad y(0) = k_0, \quad y'(0) = k_1$$

have a solution? What are the solutions?

- (d) Show that if  $x_0 \neq 0$  and  $k_0, k_1$  are arbitrary constants, the initial value problem

$$x^2y'' - 4xy' + 6y = 0, \quad y(x_0) = k_0, \quad y'(x_0) = k_1 \quad (\text{B})$$

has infinitely many solutions on  $(-\infty, \infty)$ . On what interval does (B) have a unique solution?

43. (a) Verify that  $y_1 = x$  and  $y_2 = x^2$  satisfy

$$x^2y'' - 2xy' + 2y = 0 \quad (\text{A})$$

on  $(-\infty, \infty)$  and that  $\{y_1, y_2\}$  is a fundamental set of solutions of (A) on  $(-\infty, 0)$  and  $(0, \infty)$ .

- (b) Let  $a_1, a_2, b_1,$  and  $b_2$  be constants. Show that

$$y = \begin{cases} a_1x + a_2x^2, & x \geq 0, \\ b_1x + b_2x^2, & x < 0 \end{cases}$$

is a solution of (A) on  $(-\infty, \infty)$  if and only if  $a_1 = b_1$  and  $a_2 = b_2$ . From this, justify the statement that the general solution of (A) on  $(-\infty, \infty)$  is  $y = c_1x + c_2x^2$ , where  $c_1$  and  $c_2$  are arbitrary constants.

- (c) For what values of  $k_0$  and  $k_1$  does the initial value problem

$$x^2y'' - 2xy' + 2y = 0, \quad y(0) = k_0, \quad y'(0) = k_1$$

have a solution? What are the solutions?

- (d) Show that if  $x_0 \neq 0$  and  $k_0, k_1$  are arbitrary constants then the initial value problem

$$x^2y'' - 2xy' + 2y = 0, \quad y(x_0) = k_0, \quad y'(x_0) = k_1$$

has a unique solution on  $(-\infty, \infty)$ .

44. (a) Verify that  $y_1 = x^3$  and  $y_2 = x^4$  satisfy

$$x^2y'' - 6xy' + 12y = 0 \quad (\text{A})$$

on  $(-\infty, \infty)$ , and that  $\{y_1, y_2\}$  is a fundamental set of solutions of (A) on  $(-\infty, 0)$  and  $(0, \infty)$ .

- (b) Show that  $y$  is a solution of (A) on  $(-\infty, \infty)$  if and only if

$$y = \begin{cases} a_1x^3 + a_2x^4, & x \geq 0, \\ b_1x^3 + b_2x^4, & x < 0, \end{cases}$$

where  $a_1, a_2, b_1,$  and  $b_2$  are arbitrary constants.

- (c) For what values of  $k_0$  and  $k_1$  does the initial value problem

$$x^2y'' - 6xy' + 12y = 0, \quad y(0) = k_0, \quad y'(0) = k_1$$

have a solution? What are the solutions?

- (d) Show that if  $x_0 \neq 0$  and  $k_0, k_1$  are arbitrary constants then the initial value problem

$$x^2y'' - 6xy' + 12y = 0, \quad y(x_0) = k_0, \quad y'(x_0) = k_1 \quad (\text{B})$$

has infinitely many solutions on  $(-\infty, \infty)$ . On what interval does (B) have a unique solution?

## 5.2 CONSTANT COEFFICIENT HOMOGENEOUS EQUATIONS

If  $a, b,$  and  $c$  are real constants and  $a \neq 0$ , then

$$ay'' + by' + cy = F(x)$$

is said to be a *constant coefficient equation*. In this section we consider the homogeneous constant coefficient equation

$$ay'' + by' + cy = 0. \quad (5.2.1)$$

As we'll see, all solutions of (5.2.1) are defined on  $(-\infty, \infty)$ . This being the case, we'll omit references to the interval on which solutions are defined, or on which a given set of solutions is a fundamental set, etc., since the interval will always be  $(-\infty, \infty)$ .

The key to solving (5.2.1) is that if  $y = e^{rx}$  where  $r$  is a constant then the left side of (5.2.1) is a multiple of  $e^{rx}$ ; thus, if  $y = e^{rx}$  then  $y' = re^{rx}$  and  $y'' = r^2e^{rx}$ , so

$$ay'' + by' + cy = ar^2e^{rx} + bre^{rx} + ce^{rx} = (ar^2 + br + c)e^{rx}. \quad (5.2.2)$$

The quadratic polynomial

$$p(r) = ar^2 + br + c$$

is the *characteristic polynomial* of (5.2.1), and  $p(r) = 0$  is the *characteristic equation*. From (5.2.2) we can see that  $y = e^{rx}$  is a solution of (5.2.1) if and only if  $p(r) = 0$ .

The roots of the characteristic equation are given by the quadratic formula

$$r = \frac{-b \pm \sqrt{b^2 - 4ac}}{2a}. \quad (5.2.3)$$

We consider three cases:



CASE 1.  $b^2 - 4ac > 0$ , so the characteristic equation has two distinct real roots.

CASE 2.  $b^2 - 4ac = 0$ , so the characteristic equation has a repeated real root.

CASE 3.  $b^2 - 4ac < 0$ , so the characteristic equation has complex roots.

In each case we'll start with an example.

### Case 1: Distinct Real Roots

#### Example 5.2.1

(a) Find the general solution of

$$y'' + 6y' + 5y = 0. \quad (5.2.4)$$

(b) Solve the initial value problem

$$y'' + 6y' + 5y = 0, \quad y(0) = 3, \quad y'(0) = -1. \quad (5.2.5)$$

**SOLUTION(a)** The characteristic polynomial of (5.2.4) is

$$p(r) = r^2 + 6r + 5 = (r + 1)(r + 5).$$

Since  $p(-1) = p(-5) = 0$ ,  $y_1 = e^{-x}$  and  $y_2 = e^{-5x}$  are solutions of (5.2.4). Since  $y_2/y_1 = e^{-4x}$  is nonconstant, 5.1.6 implies that the general solution of (5.2.4) is

$$y = c_1 e^{-x} + c_2 e^{-5x}. \quad (5.2.6)$$

**SOLUTION(b)** We must determine  $c_1$  and  $c_2$  in (5.2.6) so that  $y$  satisfies the initial conditions in (5.2.5). Differentiating (5.2.6) yields

$$y' = -c_1 e^{-x} - 5c_2 e^{-5x}. \quad (5.2.7)$$

Imposing the initial conditions  $y(0) = 3$ ,  $y'(0) = -1$  in (5.2.6) and (5.2.7) yields

$$\begin{aligned} c_1 + c_2 &= 3 \\ -c_1 - 5c_2 &= -1. \end{aligned}$$

The solution of this system is  $c_1 = 7/2$ ,  $c_2 = -1/2$ . Therefore the solution of (5.2.5) is

$$y = \frac{7}{2} e^{-x} - \frac{1}{2} e^{-5x}.$$

Figure 5.2.1 is a graph of this solution.

If the characteristic equation has arbitrary distinct real roots  $r_1$  and  $r_2$ , then  $y_1 = e^{r_1 x}$  and  $y_2 = e^{r_2 x}$  are solutions of  $ay'' + by' + cy = 0$ . Since  $y_2/y_1 = e^{(r_2 - r_1)x}$  is nonconstant, Theorem 5.1.6 implies that  $\{y_1, y_2\}$  is a fundamental set of solutions of  $ay'' + by' + cy = 0$ .

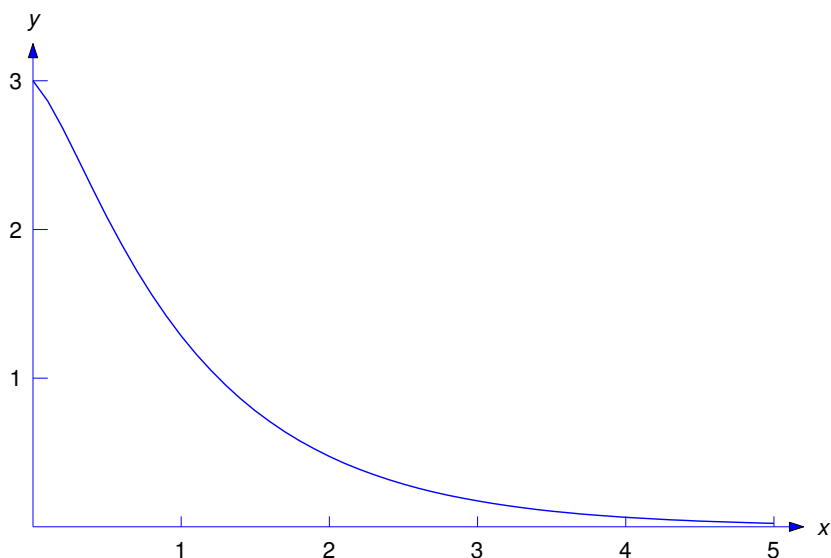

Figure 5.2.1  $y = \frac{7}{2}e^{-x} - \frac{1}{2}e^{-5x}$

### Case 2: A Repeated Real Root

#### Example 5.2.2

(a) Find the general solution of

$$y'' + 6y' + 9y = 0. \quad (5.2.8)$$

(b) Solve the initial value problem

$$y'' + 6y' + 9y = 0, \quad y(0) = 3, \quad y'(0) = -1. \quad (5.2.9)$$

**SOLUTION(a)** The characteristic polynomial of (5.2.8) is

$$p(r) = r^2 + 6r + 9 = (r + 3)^2,$$

so the characteristic equation has the repeated real root  $r_1 = -3$ . Therefore  $y_1 = e^{-3x}$  is a solution of (5.2.8). Since the characteristic equation has no other roots, (5.2.8) has no other solutions of the form  $e^{rx}$ . We look for solutions of the form  $y = uy_1 = ue^{-3x}$ , where  $u$  is a function that we'll now determine. (This should remind you of the method of variation of parameters used in Section 2.1 to solve the nonhomogeneous equation  $y' + p(x)y = f(x)$ , given a solution  $y_1$  of the complementary equation  $y' + p(x)y = 0$ . It's also a special case of a method called *reduction of order* that we'll study in Section 5.6. For other ways to obtain a second solution of (5.2.8) that's not a multiple of  $e^{-3x}$ , see Exercises 5.1.9, 5.1.12, and 33.

If  $y = ue^{-3x}$ , then

$$y' = u'e^{-3x} - 3ue^{-3x} \quad \text{and} \quad y'' = u''e^{-3x} - 6u'e^{-3x} + 9ue^{-3x},$$

so

$$\begin{aligned} y'' + 6y' + 9y &= e^{-3x} [(u'' - 6u' + 9u) + 6(u' - 3u) + 9u] \\ &= e^{-3x} [u'' - (6 - 6)u' + (9 - 18 + 9)u] = u''e^{-3x}. \end{aligned}$$

Therefore  $y = ue^{-3x}$  is a solution of (5.2.8) if and only if  $u'' = 0$ , which is equivalent to  $u = c_1 + c_2x$ , where  $c_1$  and  $c_2$  are constants. Therefore any function of the form

$$y = e^{-3x}(c_1 + c_2x) \tag{5.2.10}$$

is a solution of (5.2.8). Letting  $c_1 = 1$  and  $c_2 = 0$  yields the solution  $y_1 = e^{-3x}$  that we already knew. Letting  $c_1 = 0$  and  $c_2 = 1$  yields the second solution  $y_2 = xe^{-3x}$ . Since  $y_2/y_1 = x$  is nonconstant, 5.1.6 implies that  $\{y_1, y_2\}$  is fundamental set of solutions of (5.2.8), and (5.2.10) is the general solution.

**SOLUTION(b)** Differentiating (5.2.10) yields

$$y' = -3e^{-3x}(c_1 + c_2x) + c_2e^{-3x}. \tag{5.2.11}$$

Imposing the initial conditions  $y(0) = 3$ ,  $y'(0) = -1$  in (5.2.10) and (5.2.11) yields  $c_1 = 3$  and  $-3c_1 + c_2 = -1$ , so  $c_2 = 8$ . Therefore the solution of (5.2.9) is

$$y = e^{-3x}(3 + 8x).$$

Figure 5.2.2 is a graph of this solution.

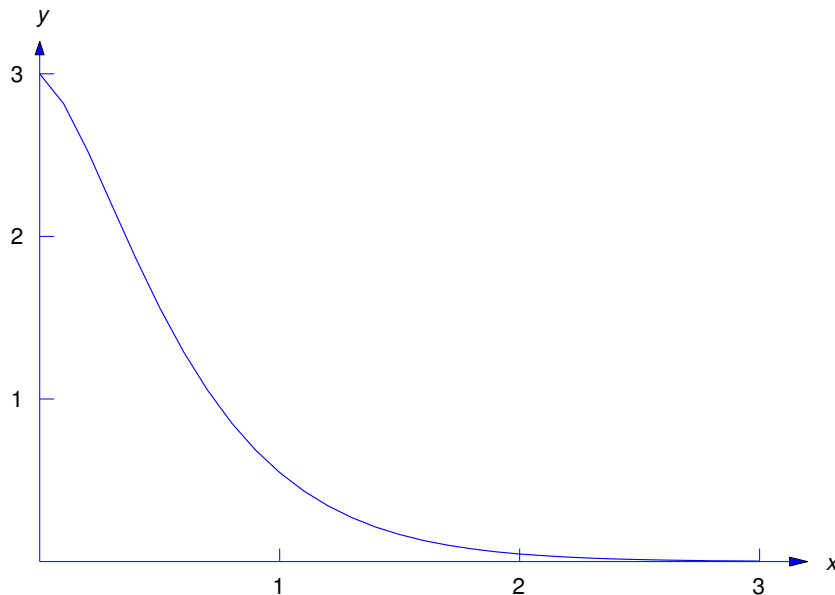

Figure 5.2.2  $y = e^{-3x}(3 + 8x)$

If the characteristic equation of  $ay'' + by' + cy = 0$  has an arbitrary repeated root  $r_1$ , the characteristic polynomial must be

$$p(r) = a(r - r_1)^2 = a(r^2 - 2r_1r + r_1^2).$$

Therefore

$$ar^2 + br + c = ar^2 - (2ar_1)r + ar_1^2,$$

which implies that  $b = -2ar_1$  and  $c = ar_1^2$ . Therefore  $ay'' + by' + cy = 0$  can be written as  $a(y'' - 2r_1y' + r_1^2y) = 0$ . Since  $a \neq 0$  this equation has the same solutions as

$$y'' - 2r_1y' + r_1^2y = 0. \quad (5.2.12)$$

Since  $p(r_1) = 0$ ,  $y_1 = e^{r_1x}$  is a solution of  $ay'' + by' + cy = 0$ , and therefore of (5.2.12). Proceeding as in Example 5.2.2, we look for other solutions of (5.2.12) of the form  $y = ue^{r_1x}$ ; then

$$y' = u'e^{r_1x} + rue^{r_1x} \quad \text{and} \quad y'' = u''e^{r_1x} + 2r_1u'e^{r_1x} + r_1^2ue^{r_1x},$$

so

$$\begin{aligned} y'' - 2r_1y' + r_1^2y &= e^{r_1x} [(u'' + 2r_1u' + r_1^2u) - 2r_1(u' + r_1u) + r_1^2u] \\ &= e^{r_1x} [u'' + (2r_1 - 2r_1)u' + (r_1^2 - 2r_1^2 + r_1^2)u] = u''e^{r_1x}. \end{aligned}$$

Therefore  $y = ue^{r_1x}$  is a solution of (5.2.12) if and only if  $u'' = 0$ , which is equivalent to  $u = c_1 + c_2x$ , where  $c_1$  and  $c_2$  are constants. Hence, any function of the form

$$y = e^{r_1x}(c_1 + c_2x) \quad (5.2.13)$$

is a solution of (5.2.12). Letting  $c_1 = 1$  and  $c_2 = 0$  here yields the solution  $y_1 = e^{r_1x}$  that we already knew. Letting  $c_1 = 0$  and  $c_2 = 1$  yields the second solution  $y_2 = xe^{r_1x}$ . Since  $y_2/y_1 = x$  is nonconstant, 5.1.6 implies that  $\{y_1, y_2\}$  is a fundamental set of solutions of (5.2.12), and (5.2.13) is the general solution.

### Case 3: Complex Conjugate Roots

#### Example 5.2.3

(a) Find the general solution of

$$y'' + 4y' + 13y = 0. \quad (5.2.14)$$

(b) Solve the initial value problem

$$y'' + 4y' + 13y = 0, \quad y(0) = 2, \quad y'(0) = -3. \quad (5.2.15)$$

**SOLUTION(a)** The characteristic polynomial of (5.2.14) is

$$p(r) = r^2 + 4r + 13 = r^2 + 4r + 4 + 9 = (r + 2)^2 + 9.$$

The roots of the characteristic equation are  $r_1 = -2 + 3i$  and  $r_2 = -2 - 3i$ . By analogy with Case 1, it's reasonable to expect that  $e^{(-2+3i)x}$  and  $e^{(-2-3i)x}$  are solutions of (5.2.14). This is true (see Exercise 34); however, there are difficulties here, since you are probably not familiar with exponential functions with complex arguments, and even if you are, it's inconvenient to work with them, since they are complex-valued. We'll take a simpler approach, which we motivate as follows: the exponential notation suggests that

$$e^{(-2+3i)x} = e^{-2x}e^{3ix} \quad \text{and} \quad e^{(-2-3i)x} = e^{-2x}e^{-3ix},$$

so even though we haven't defined  $e^{3ix}$  and  $e^{-3ix}$ , it's reasonable to expect that every linear combination of  $e^{(-2+3i)x}$  and  $e^{(-2-3i)x}$  can be written as  $y = ue^{-2x}$ , where  $u$  depends upon  $x$ . To determine  $u$ , we note that if  $y = ue^{-2x}$  then

$$y' = u'e^{-2x} - 2ue^{-2x} \quad \text{and} \quad y'' = u''e^{-2x} - 4u'e^{-2x} + 4ue^{-2x},$$

so

$$\begin{aligned} y'' + 4y' + 13y &= e^{-2x} [(u'' - 4u' + 4u) + 4(u' - 2u) + 13u] \\ &= e^{-2x} [u'' - (4 - 4)u' + (4 - 8 + 13)u] = e^{-2x}(u'' + 9u). \end{aligned}$$

Therefore  $y = ue^{-2x}$  is a solution of (5.2.14) if and only if

$$u'' + 9u = 0.$$

From Example 5.1.2, the general solution of this equation is

$$u = c_1 \cos 3x + c_2 \sin 3x.$$

Therefore any function of the form

$$y = e^{-2x}(c_1 \cos 3x + c_2 \sin 3x) \tag{5.2.16}$$

is a solution of (5.2.14). Letting  $c_1 = 1$  and  $c_2 = 0$  yields the solution  $y_1 = e^{-2x} \cos 3x$ . Letting  $c_1 = 0$  and  $c_2 = 1$  yields the second solution  $y_2 = e^{-2x} \sin 3x$ . Since  $y_2/y_1 = \tan 3x$  is nonconstant, 5.1.6 implies that  $\{y_1, y_2\}$  is a fundamental set of solutions of (5.2.14), and (5.2.16) is the general solution.

**SOLUTION(b)** Imposing the condition  $y(0) = 2$  in (5.2.16) shows that  $c_1 = 2$ . Differentiating (5.2.16) yields

$$y' = -2e^{-2x}(c_1 \cos 3x + c_2 \sin 3x) + 3e^{-2x}(-c_1 \sin 3x + c_2 \cos 3x),$$

and imposing the initial condition  $y'(0) = -3$  here yields  $-3 = -2c_1 + 3c_2 = -4 + 3c_2$ , so  $c_2 = 1/3$ . Therefore the solution of (5.2.15) is

$$y = e^{-2x}\left(2 \cos 3x + \frac{1}{3} \sin 3x\right).$$

Figure 5.2.3 is a graph of this function. ■

Now suppose the characteristic equation of  $ay'' + by' + cy = 0$  has arbitrary complex roots; thus,  $b^2 - 4ac < 0$  and, from (5.2.3), the roots are

$$r_1 = \frac{-b + i\sqrt{4ac - b^2}}{2a}, \quad r_2 = \frac{-b - i\sqrt{4ac - b^2}}{2a},$$

which we rewrite as

$$r_1 = \lambda + i\omega, \quad r_2 = \lambda - i\omega, \tag{5.2.17}$$

with

$$\lambda = -\frac{b}{2a}, \quad \omega = \frac{\sqrt{4ac - b^2}}{2a}.$$

Don't memorize these formulas. Just remember that  $r_1$  and  $r_2$  are of the form (5.2.17), where  $\lambda$  is an arbitrary real number and  $\omega$  is positive;  $\lambda$  and  $\omega$  are the *real* and *imaginary parts*, respectively, of  $r_1$ . Similarly,  $\lambda$  and  $-\omega$  are the real and imaginary parts of  $r_2$ . We say that  $r_1$  and  $r_2$  are *complex conjugates*,

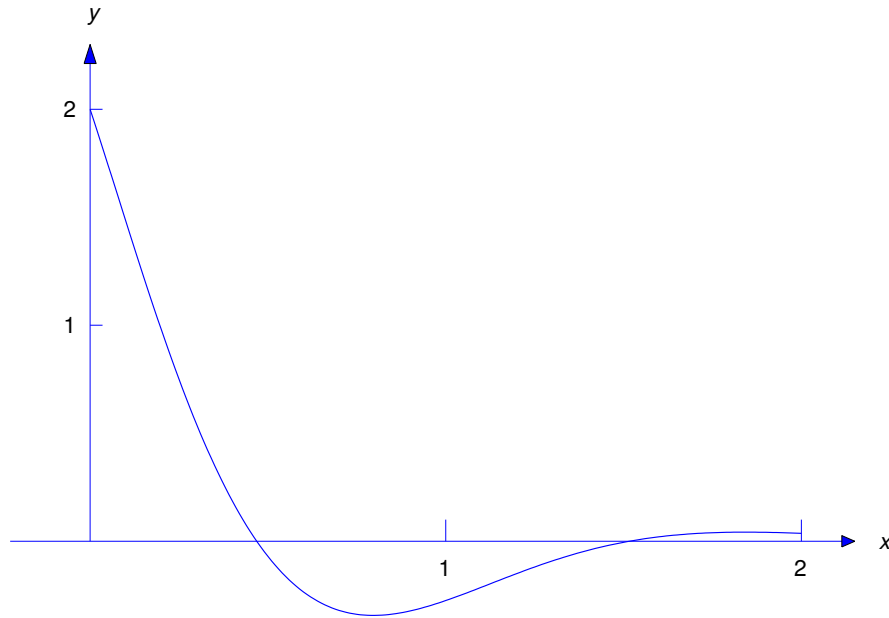

Figure 5.2.3  $y = e^{-2x}(2 \cos 3x + \frac{1}{3} \sin 3x)$

which means that they have the same real part and their imaginary parts have the same absolute values, but opposite signs.

As in Example 5.2.3, it's reasonable to expect that the solutions of  $ay'' + by' + cy = 0$  are linear combinations of  $e^{(\lambda+i\omega)x}$  and  $e^{(\lambda-i\omega)x}$ . Again, the exponential notation suggests that

$$e^{(\lambda+i\omega)x} = e^{\lambda x} e^{i\omega x} \quad \text{and} \quad e^{(\lambda-i\omega)x} = e^{\lambda x} e^{-i\omega x},$$

so even though we haven't defined  $e^{i\omega x}$  and  $e^{-i\omega x}$ , it's reasonable to expect that every linear combination of  $e^{(\lambda+i\omega)x}$  and  $e^{(\lambda-i\omega)x}$  can be written as  $y = ue^{\lambda x}$ , where  $u$  depends upon  $x$ . To determine  $u$  we first observe that since  $r_1 = \lambda + i\omega$  and  $r_2 = \lambda - i\omega$  are the roots of the characteristic equation,  $p$  must be of the form

$$\begin{aligned} p(r) &= a(r - r_1)(r - r_2) \\ &= a(r - \lambda - i\omega)(r - \lambda + i\omega) \\ &= a[(r - \lambda)^2 + \omega^2] \\ &= a(r^2 - 2\lambda r + \lambda^2 + \omega^2). \end{aligned}$$

Therefore  $ay'' + by' + cy = 0$  can be written as

$$a[y'' - 2\lambda y' + (\lambda^2 + \omega^2)y] = 0.$$

Since  $a \neq 0$  this equation has the same solutions as

$$y'' - 2\lambda y' + (\lambda^2 + \omega^2)y = 0. \quad (5.2.18)$$

To determine  $u$  we note that if  $y = ue^{\lambda x}$  then

$$y' = u'e^{\lambda x} + \lambda ue^{\lambda x} \quad \text{and} \quad y'' = u''e^{\lambda x} + 2\lambda u'e^{\lambda x} + \lambda^2 ue^{\lambda x}.$$

Substituting these expressions into (5.2.18) and dropping the common factor  $e^{\lambda x}$  yields

$$(u'' + 2\lambda u' + \lambda^2 u) - 2\lambda(u' + \lambda u) + (\lambda^2 + \omega^2)u = 0,$$

which simplifies to

$$u'' + \omega^2 u = 0.$$

From Example 5.1.2, the general solution of this equation is

$$u = c_1 \cos \omega x + c_2 \sin \omega x.$$

Therefore any function of the form

$$y = e^{\lambda x}(c_1 \cos \omega x + c_2 \sin \omega x) \quad (5.2.19)$$

is a solution of (5.2.18). Letting  $c_1 = 1$  and  $c_2 = 0$  here yields the solution  $y_1 = e^{\lambda x} \cos \omega x$ . Letting  $c_1 = 0$  and  $c_2 = 1$  yields a second solution  $y_2 = e^{\lambda x} \sin \omega x$ . Since  $y_2/y_1 = \tan \omega x$  is nonconstant, so Theorem 5.1.6 implies that  $\{y_1, y_2\}$  is a fundamental set of solutions of (5.2.18), and (5.2.19) is the general solution.

### Summary

The next theorem summarizes the results of this section.

**Theorem 5.2.1** *Let  $p(r) = ar^2 + br + c$  be the characteristic polynomial of*

$$ay'' + by' + cy = 0. \quad (5.2.20)$$

*Then:*

(a) *If  $p(r) = 0$  has distinct real roots  $r_1$  and  $r_2$ , then the general solution of (5.2.20) is*

$$y = c_1 e^{r_1 x} + c_2 e^{r_2 x}.$$

(b) *If  $p(r) = 0$  has a repeated root  $r_1$ , then the general solution of (5.2.20) is*

$$y = e^{r_1 x}(c_1 + c_2 x).$$

(c) *If  $p(r) = 0$  has complex conjugate roots  $r_1 = \lambda + i\omega$  and  $r_2 = \lambda - i\omega$  (where  $\omega > 0$ ), then the general solution of (5.2.20) is*

$$y = e^{\lambda x}(c_1 \cos \omega x + c_2 \sin \omega x).$$

## 5.2 Exercises

---

In Exercises 1–12 find the general solution.

1.  $y'' + 5y' - 6y = 0$

2.  $y'' - 4y' + 5y = 0$

3.  $y'' + 8y' + 7y = 0$

4.  $y'' - 4y' + 4y = 0$

5.  $y'' + 2y' + 10y = 0$

6.  $y'' + 6y' + 10y = 0$

7.  $y'' - 8y' + 16y = 0$                       8.  $y'' + y' = 0$   
 9.  $y'' - 2y' + 3y = 0$                       10.  $y'' + 6y' + 13y = 0$   
 11.  $4y'' + 4y' + 10y = 0$                 12.  $10y'' - 3y' - y = 0$

In Exercises 13–17 solve the initial value problem.

13.  $y'' + 14y' + 50y = 0$ ,  $y(0) = 2$ ,  $y'(0) = -17$   
 14.  $6y'' - y' - y = 0$ ,  $y(0) = 10$ ,  $y'(0) = 0$   
 15.  $6y'' + y' - y = 0$ ,  $y(0) = -1$ ,  $y'(0) = 3$   
 16.  $4y'' - 4y' - 3y = 0$ ,  $y(0) = \frac{13}{12}$ ,  $y'(0) = \frac{23}{24}$   
 17.  $4y'' - 12y' + 9y = 0$ ,  $y(0) = 3$ ,  $y'(0) = \frac{5}{2}$

In Exercises 18–21 solve the initial value problem and graph the solution.

18. C/G  $y'' + 7y' + 12y = 0$ ,  $y(0) = -1$ ,  $y'(0) = 0$   
 19. C/G  $y'' - 6y' + 9y = 0$ ,  $y(0) = 0$ ,  $y'(0) = 2$   
 20. C/G  $36y'' - 12y' + y = 0$ ,  $y(0) = 3$ ,  $y'(0) = \frac{5}{2}$   
 21. C/G  $y'' + 4y' + 10y = 0$ ,  $y(0) = 3$ ,  $y'(0) = -2$   
 22. (a) Suppose  $y$  is a solution of the constant coefficient homogeneous equation

$$ay'' + by' + cy = 0. \tag{A}$$

Let  $z(x) = y(x - x_0)$ , where  $x_0$  is an arbitrary real number. Show that

$$az'' + bz' + cz = 0.$$

- (b) Let  $z_1(x) = y_1(x - x_0)$  and  $z_2(x) = y_2(x - x_0)$ , where  $\{y_1, y_2\}$  is a fundamental set of solutions of (A). Show that  $\{z_1, z_2\}$  is also a fundamental set of solutions of (A).  
 (c) The statement of Theorem 5.2.1 is convenient for solving an initial value problem

$$ay'' + by' + cy = 0, \quad y(0) = k_0, \quad y'(0) = k_1,$$

where the initial conditions are imposed at  $x_0 = 0$ . However, if the initial value problem is

$$ay'' + by' + cy = 0, \quad y(x_0) = k_0, \quad y'(x_0) = k_1, \tag{B}$$

where  $x_0 \neq 0$ , then determining the constants in

$$y = c_1 e^{r_1 x} + c_2 e^{r_2 x}, \quad y = e^{r_1 x}(c_1 + c_2 x), \quad \text{or } y = e^{\lambda x}(c_1 \cos \omega x + c_2 \sin \omega x)$$

(whichever is applicable) is more complicated. Use (b) to restate Theorem 5.2.1 in a form more convenient for solving (B).

In Exercises 23–28 use a method suggested by Exercise 22 to solve the initial value problem.

23.  $y'' + 3y' + 2y = 0$ ,  $y(1) = -1$ ,  $y'(1) = 4$



24.  $y'' - 6y' - 7y = 0$ ,  $y(2) = -\frac{1}{3}$ ,  $y'(2) = -5$   
 25.  $y'' - 14y' + 49y = 0$ ,  $y(1) = 2$ ,  $y'(1) = 11$   
 26.  $9y'' + 6y' + y = 0$ ,  $y(2) = 2$ ,  $y'(2) = -\frac{14}{3}$   
 27.  $9y'' + 4y = 0$ ,  $y(\pi/4) = 2$ ,  $y'(\pi/4) = -2$   
 28.  $y'' + 3y = 0$ ,  $y(\pi/3) = 2$ ,  $y'(\pi/3) = -1$   
 29. Prove: If the characteristic equation of

$$ay'' + by' + cy = 0 \quad (\text{A})$$

has a repeated negative root or two roots with negative real parts, then every solution of (A) approaches zero as  $x \rightarrow \infty$ .

30. Suppose the characteristic polynomial of  $ay'' + by' + cy = 0$  has distinct real roots  $r_1$  and  $r_2$ . Use a method suggested by Exercise 22 to find a formula for the solution of

$$ay'' + by' + cy = 0, \quad y(x_0) = k_0, \quad y'(x_0) = k_1.$$

31. Suppose the characteristic polynomial of  $ay'' + by' + cy = 0$  has a repeated real root  $r_1$ . Use a method suggested by Exercise 22 to find a formula for the solution of

$$ay'' + by' + cy = 0, \quad y(x_0) = k_0, \quad y'(x_0) = k_1.$$

32. Suppose the characteristic polynomial of  $ay'' + by' + cy = 0$  has complex conjugate roots  $\lambda \pm i\omega$ . Use a method suggested by Exercise 22 to find a formula for the solution of

$$ay'' + by' + cy = 0, \quad y(x_0) = k_0, \quad y'(x_0) = k_1.$$

33. Suppose the characteristic equation of

$$ay'' + by' + cy = 0 \quad (\text{A})$$

has a repeated real root  $r_1$ . Temporarily, think of  $e^{rx}$  as a function of two real variables  $x$  and  $r$ .

- (a) Show that

$$a \frac{\partial^2}{\partial^2 x} (e^{rx}) + b \frac{\partial}{\partial x} (e^{rx}) + ce^{rx} = a(r - r_1)^2 e^{rx}. \quad (\text{B})$$

- (b) Differentiate (B) with respect to  $r$  to obtain

$$a \frac{\partial}{\partial r} \left( \frac{\partial^2}{\partial^2 x} (e^{rx}) \right) + b \frac{\partial}{\partial r} \left( \frac{\partial}{\partial x} (e^{rx}) \right) + c(xe^{rx}) = [2 + (r - r_1)x]a(r - r_1)e^{rx}. \quad (\text{C})$$

- (c) Reverse the orders of the partial differentiations in the first two terms on the left side of (C) to obtain

$$a \frac{\partial^2}{\partial x^2} (xe^{rx}) + b \frac{\partial}{\partial x} (xe^{rx}) + c(xe^{rx}) = [2 + (r - r_1)x]a(r - r_1)e^{rx}. \quad (\text{D})$$

- (d) Set  $r = r_1$  in (B) and (D) to see that  $y_1 = e^{r_1 x}$  and  $y_2 = xe^{r_1 x}$  are solutions of (A)

34. In calculus you learned that  $e^u$ ,  $\cos u$ , and  $\sin u$  can be represented by the infinite series

$$e^u = \sum_{n=0}^{\infty} \frac{u^n}{n!} = 1 + \frac{u}{1!} + \frac{u^2}{2!} + \frac{u^3}{3!} + \cdots + \frac{u^n}{n!} + \cdots \quad (\text{A})$$

$$\cos u = \sum_{n=0}^{\infty} (-1)^n \frac{u^{2n}}{(2n)!} = 1 - \frac{u^2}{2!} + \frac{u^4}{4!} + \cdots + (-1)^n \frac{u^{2n}}{(2n)!} + \cdots, \quad (\text{B})$$

and

$$\sin u = \sum_{n=0}^{\infty} (-1)^n \frac{u^{2n+1}}{(2n+1)!} = u - \frac{u^3}{3!} + \frac{u^5}{5!} + \cdots + (-1)^n \frac{u^{2n+1}}{(2n+1)!} + \cdots \quad (\text{C})$$

for all real values of  $u$ . Even though you have previously considered (A) only for real values of  $u$ , we can set  $u = i\theta$ , where  $\theta$  is real, to obtain

$$e^{i\theta} = \sum_{n=0}^{\infty} \frac{(i\theta)^n}{n!}. \quad (\text{D})$$

Given the proper background in the theory of infinite series with complex terms, it can be shown that the series in (D) converges for all real  $\theta$ .

(a) Recalling that  $i^2 = -1$ , write enough terms of the sequence  $\{i^n\}$  to convince yourself that the sequence is repetitive:

$$1, i, -1, -i, 1, i, -1, -i, 1, i, -1, -i, 1, i, -1, -i, \dots$$

Use this to group the terms in (D) as

$$\begin{aligned} e^{i\theta} &= \left(1 - \frac{\theta^2}{2} + \frac{\theta^4}{4} + \cdots\right) + i \left(\theta - \frac{\theta^3}{3!} + \frac{\theta^5}{5!} + \cdots\right) \\ &= \sum_{n=0}^{\infty} (-1)^n \frac{\theta^{2n}}{(2n)!} + i \sum_{n=0}^{\infty} (-1)^n \frac{\theta^{2n+1}}{(2n+1)!}. \end{aligned}$$

By comparing this result with (B) and (C), conclude that

$$e^{i\theta} = \cos \theta + i \sin \theta. \quad (\text{E})$$

This is *Euler's identity*.

(b) Starting from

$$e^{i\theta_1} e^{i\theta_2} = (\cos \theta_1 + i \sin \theta_1)(\cos \theta_2 + i \sin \theta_2),$$

collect the real part (the terms not multiplied by  $i$ ) and the imaginary part (the terms multiplied by  $i$ ) on the right, and use the trigonometric identities

$$\begin{aligned} \cos(\theta_1 + \theta_2) &= \cos \theta_1 \cos \theta_2 - \sin \theta_1 \sin \theta_2 \\ \sin(\theta_1 + \theta_2) &= \sin \theta_1 \cos \theta_2 + \cos \theta_1 \sin \theta_2 \end{aligned}$$

to verify that

$$e^{i(\theta_1 + \theta_2)} = e^{i\theta_1} e^{i\theta_2},$$

as you would expect from the use of the exponential notation  $e^{i\theta}$ .

(c) If  $\alpha$  and  $\beta$  are real numbers, define

$$e^{\alpha+i\beta} = e^\alpha e^{i\beta} = e^\alpha (\cos \beta + i \sin \beta). \quad (\text{F})$$

Show that if  $z_1 = \alpha_1 + i\beta_1$  and  $z_2 = \alpha_2 + i\beta_2$  then

$$e^{z_1+z_2} = e^{z_1} e^{z_2}.$$

(d) Let  $a$ ,  $b$ , and  $c$  be real numbers, with  $a \neq 0$ . Let  $z = u + iv$  where  $u$  and  $v$  are real-valued functions of  $x$ . Then we say that  $z$  is a solution of

$$ay'' + by' + cy = 0 \quad (\text{G})$$

if  $u$  and  $v$  are both solutions of (G). Use Theorem 5.2.1(c) to verify that if the characteristic equation of (G) has complex conjugate roots  $\lambda \pm i\omega$  then  $z_1 = e^{(\lambda+i\omega)x}$  and  $z_2 = e^{(\lambda-i\omega)x}$  are both solutions of (G).

### 5.3 NONHOMOGENEOUS LINEAR EQUATIONS

We'll now consider the nonhomogeneous linear second order equation

$$y'' + p(x)y' + q(x)y = f(x), \quad (5.3.1)$$

where the forcing function  $f$  isn't identically zero. The next theorem, an extension of Theorem 5.1.1, gives sufficient conditions for existence and uniqueness of solutions of initial value problems for (5.3.1). We omit the proof, which is beyond the scope of this book.

**Theorem 5.3.1** *Suppose  $p$ ,  $q$  and  $f$  are continuous on an open interval  $(a, b)$ , let  $x_0$  be any point in  $(a, b)$ , and let  $k_0$  and  $k_1$  be arbitrary real numbers. Then the initial value problem*

$$y'' + p(x)y' + q(x)y = f(x), \quad y(x_0) = k_0, \quad y'(x_0) = k_1$$

*has a unique solution on  $(a, b)$ .*

To find the general solution of (5.3.1) on an interval  $(a, b)$  where  $p$ ,  $q$ , and  $f$  are continuous, it's necessary to find the general solution of the associated homogeneous equation

$$y'' + p(x)y' + q(x)y = 0 \quad (5.3.2)$$

on  $(a, b)$ . We call (5.3.2) the *complementary equation* for (5.3.1).

The next theorem shows how to find the general solution of (5.3.1) if we know one solution  $y_p$  of (5.3.1) and a fundamental set of solutions of (5.3.2). We call  $y_p$  a *particular solution* of (5.3.1); it can be any solution that we can find, one way or another.

**Theorem 5.3.2** *Suppose  $p$ ,  $q$ , and  $f$  are continuous on  $(a, b)$ . Let  $y_p$  be a particular solution of*

$$y'' + p(x)y' + q(x)y = f(x) \quad (5.3.3)$$

*on  $(a, b)$ , and let  $\{y_1, y_2\}$  be a fundamental set of solutions of the complementary equation*

$$y'' + p(x)y' + q(x)y = 0 \quad (5.3.4)$$

*on  $(a, b)$ . Then  $y$  is a solution of (5.3.3) on  $(a, b)$  if and only if*

$$y = y_p + c_1 y_1 + c_2 y_2, \quad (5.3.5)$$

*where  $c_1$  and  $c_2$  are constants.*

**Proof** We first show that  $y$  in (5.3.5) is a solution of (5.3.3) for any choice of the constants  $c_1$  and  $c_2$ . Differentiating (5.3.5) twice yields

$$y' = y'_p + c_1y'_1 + c_2y'_2 \quad \text{and} \quad y'' = y''_p + c_1y''_1 + c_2y''_2,$$

so

$$\begin{aligned} y'' + p(x)y' + q(x)y &= (y''_p + c_1y''_1 + c_2y''_2) + p(x)(y'_p + c_1y'_1 + c_2y'_2) \\ &\quad + q(x)(y_p + c_1y_1 + c_2y_2) \\ &= (y''_p + p(x)y'_p + q(x)y_p) + c_1(y''_1 + p(x)y'_1 + q(x)y_1) \\ &\quad + c_2(y''_2 + p(x)y'_2 + q(x)y_2) \\ &= f + c_1 \cdot 0 + c_2 \cdot 0 = f, \end{aligned}$$

since  $y_p$  satisfies (5.3.3) and  $y_1$  and  $y_2$  satisfy (5.3.4).

Now we'll show that every solution of (5.3.3) has the form (5.3.5) for some choice of the constants  $c_1$  and  $c_2$ . Suppose  $y$  is a solution of (5.3.3). We'll show that  $y - y_p$  is a solution of (5.3.4), and therefore of the form  $y - y_p = c_1y_1 + c_2y_2$ , which implies (5.3.5). To see this, we compute

$$\begin{aligned} (y - y_p)'' + p(x)(y - y_p)' + q(x)(y - y_p) &= (y'' - y''_p) + p(x)(y' - y'_p) \\ &\quad + q(x)(y - y_p) \\ &= (y'' + p(x)y' + q(x)y) \\ &\quad - (y''_p + p(x)y'_p + q(x)y_p) \\ &= f(x) - f(x) = 0, \end{aligned}$$

since  $y$  and  $y_p$  both satisfy (5.3.3). ■

We say that (5.3.5) is the *general solution of (5.3.3) on  $(a, b)$* .

If  $P_0$ ,  $P_1$ , and  $F$  are continuous and  $P_0$  has no zeros on  $(a, b)$ , then Theorem 5.3.2 implies that the general solution of

$$P_0(x)y'' + P_1(x)y' + P_2(x)y = F(x) \tag{5.3.6}$$

on  $(a, b)$  is  $y = y_p + c_1y_1 + c_2y_2$ , where  $y_p$  is a particular solution of (5.3.6) on  $(a, b)$  and  $\{y_1, y_2\}$  is a fundamental set of solutions of

$$P_0(x)y'' + P_1(x)y' + P_2(x)y = 0$$

on  $(a, b)$ . To see this, we rewrite (5.3.6) as

$$y'' + \frac{P_1(x)}{P_0(x)}y' + \frac{P_2(x)}{P_0(x)}y = \frac{F(x)}{P_0(x)}$$

and apply Theorem 5.3.2 with  $p = P_1/P_0$ ,  $q = P_2/P_0$ , and  $f = F/P_0$ .

To avoid awkward wording in examples and exercises, we won't specify the interval  $(a, b)$  when we ask for the general solution of a specific linear second order equation, or for a fundamental set of solutions of a homogeneous linear second order equation. Let's agree that this always means that we want the general solution (or a fundamental set of solutions, as the case may be) on every open interval on which  $p$ ,  $q$ , and  $f$  are continuous if the equation is of the form (5.3.3), or on which  $P_0$ ,  $P_1$ ,  $P_2$ , and  $F$  are continuous and  $P_0$  has no zeros, if the equation is of the form (5.3.6). We leave it to you to identify these intervals in specific examples and exercises.

For completeness, we point out that if  $P_0$ ,  $P_1$ ,  $P_2$ , and  $F$  are all continuous on an open interval  $(a, b)$ , but  $P_0$  *does* have a zero in  $(a, b)$ , then (5.3.6) may fail to have a general solution on  $(a, b)$  in the sense just defined. Exercises 42–44 illustrate this point for a homogeneous equation.

In this section we limit ourselves to applications of Theorem 5.3.2 where we can guess at the form of the particular solution.

**Example 5.3.1**

(a) Find the general solution of

$$y'' + y = 1. \quad (5.3.7)$$

(b) Solve the initial value problem

$$y'' + y = 1, \quad y(0) = 2, \quad y'(0) = 7. \quad (5.3.8)$$

**SOLUTION(a)** We can apply Theorem 5.3.2 with  $(a, b) = (-\infty, \infty)$ , since the functions  $p \equiv 0$ ,  $q \equiv 1$ , and  $f \equiv 1$  in (5.3.7) are continuous on  $(-\infty, \infty)$ . By inspection we see that  $y_p \equiv 1$  is a particular solution of (5.3.7). Since  $y_1 = \cos x$  and  $y_2 = \sin x$  form a fundamental set of solutions of the complementary equation  $y'' + y = 0$ , the general solution of (5.3.7) is

$$y = 1 + c_1 \cos x + c_2 \sin x. \quad (5.3.9)$$

**SOLUTION(b)** Imposing the initial condition  $y(0) = 2$  in (5.3.9) yields  $2 = 1 + c_1$ , so  $c_1 = 1$ . Differentiating (5.3.9) yields

$$y' = -c_1 \sin x + c_2 \cos x.$$

Imposing the initial condition  $y'(0) = 7$  here yields  $c_2 = 7$ , so the solution of (5.3.8) is

$$y = 1 + \cos x + 7 \sin x.$$

Figure 5.3.1 is a graph of this function.

**Example 5.3.2**

(a) Find the general solution of

$$y'' - 2y' + y = -3 - x + x^2. \quad (5.3.10)$$

(b) Solve the initial value problem

$$y'' - 2y' + y = -3 - x + x^2, \quad y(0) = -2, \quad y'(0) = 1. \quad (5.3.11)$$

**SOLUTION(a)** The characteristic polynomial of the complementary equation

$$y'' - 2y' + y = 0$$

is  $r^2 - 2r + 1 = (r - 1)^2$ , so  $y_1 = e^x$  and  $y_2 = xe^x$  form a fundamental set of solutions of the complementary equation. To guess a form for a particular solution of (5.3.10), we note that substituting a second degree polynomial  $y_p = A + Bx + Cx^2$  into the left side of (5.3.10) will produce another second degree polynomial with coefficients that depend upon  $A$ ,  $B$ , and  $C$ . The trick is to choose  $A$ ,  $B$ , and  $C$  so the polynomials on the two sides of (5.3.10) have the same coefficients; thus, if

$$y_p = A + Bx + Cx^2 \quad \text{then} \quad y'_p = B + 2Cx \quad \text{and} \quad y''_p = 2C,$$

so

$$\begin{aligned} y''_p - 2y'_p + y_p &= 2C - 2(B + 2Cx) + (A + Bx + Cx^2) \\ &= (2C - 2B + A) + (-4C + B)x + Cx^2 = -3 - x + x^2. \end{aligned}$$

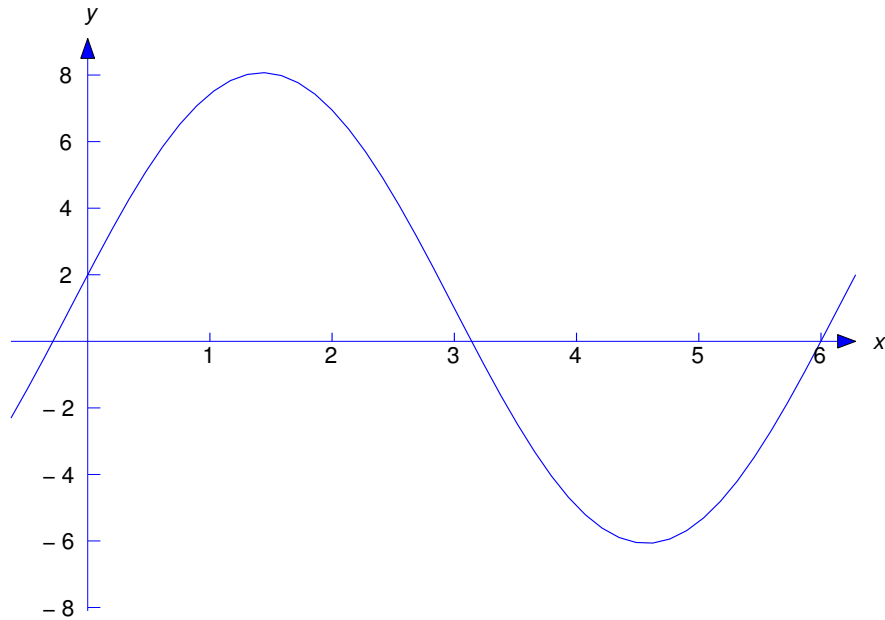

Figure 5.3.1  $y = 1 + \cos x + 7 \sin x$

Equating coefficients of like powers of  $x$  on the two sides of the last equality yields

$$\begin{aligned} C &= 1 \\ B - 4C &= -1 \\ A - 2B + 2C &= -3, \end{aligned}$$

so  $C = 1$ ,  $B = -1 + 4C = 3$ , and  $A = -3 - 2C + 2B = 1$ . Therefore  $y_p = 1 + 3x + x^2$  is a particular solution of (5.3.10) and Theorem 5.3.2 implies that

$$y = 1 + 3x + x^2 + e^x(c_1 + c_2x) \tag{5.3.12}$$

is the general solution of (5.3.10).

**SOLUTION(b)** Imposing the initial condition  $y(0) = -2$  in (5.3.12) yields  $-2 = 1 + c_1$ , so  $c_1 = -3$ . Differentiating (5.3.12) yields

$$y' = 3 + 2x + e^x(c_1 + c_2x) + c_2e^x,$$

and imposing the initial condition  $y'(0) = 1$  here yields  $1 = 3 + c_1 + c_2$ , so  $c_2 = 1$ . Therefore the solution of (5.3.11) is

$$y = 1 + 3x + x^2 - e^x(3 - x).$$

Figure 5.3.2 is a graph of this solution.

**Example 5.3.3** Find the general solution of

$$x^2y'' + xy' - 4y = 2x^4 \tag{5.3.13}$$

on  $(-\infty, 0)$  and  $(0, \infty)$ .

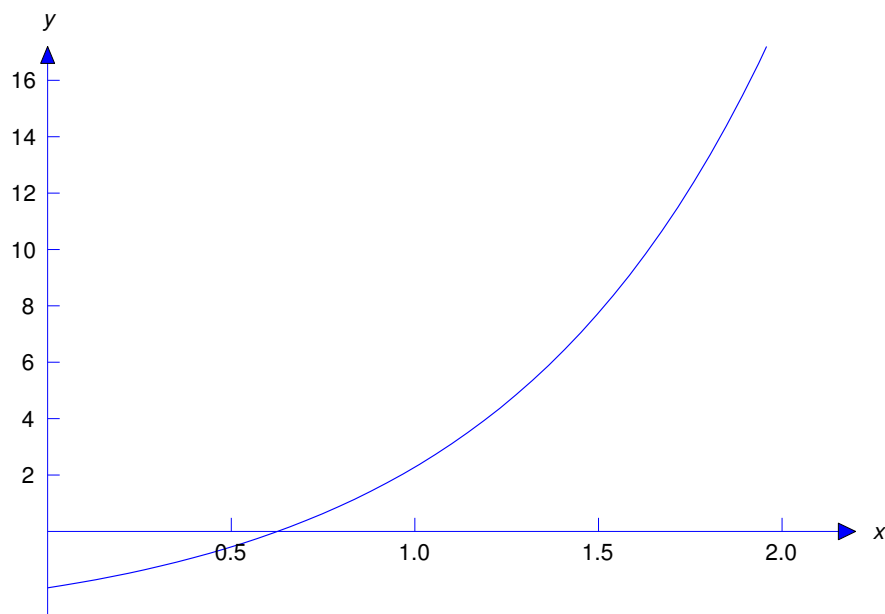
Figure 5.3.2  $y = 1 + 3x + x^2 - e^x(3 - x)$ 

**Solution** In Example 5.1.3, we verified that  $y_1 = x^2$  and  $y_2 = 1/x^2$  form a fundamental set of solutions of the complementary equation

$$x^2y'' + xy' - 4y = 0$$

on  $(-\infty, 0)$  and  $(0, \infty)$ . To find a particular solution of (5.3.13), we note that if  $y_p = Ax^4$ , where  $A$  is a constant then both sides of (5.3.13) will be constant multiples of  $x^4$  and we may be able to choose  $A$  so the two sides are equal. This is true in this example, since if  $y_p = Ax^4$  then

$$x^2y_p'' + xy_p' - 4y_p = x^2(12Ax^2) + x(4Ax^3) - 4Ax^4 = 12Ax^4 = 2x^4$$

if  $A = 1/6$ ; therefore,  $y_p = x^4/6$  is a particular solution of (5.3.13) on  $(-\infty, \infty)$ . Theorem 5.3.2 implies that the general solution of (5.3.13) on  $(-\infty, 0)$  and  $(0, \infty)$  is

$$y = \frac{x^4}{6} + c_1x^2 + \frac{c_2}{x^2}.$$

### The Principle of Superposition

The next theorem enables us to break a nonhomogeneous equation into simpler parts, find a particular solution for each part, and then combine their solutions to obtain a particular solution of the original problem.

**Theorem 5.3.3** [The Principle of Superposition] Suppose  $y_{p_1}$  is a particular solution of

$$y'' + p(x)y' + q(x)y = f_1(x)$$

on  $(a, b)$  and  $y_{p_2}$  is a particular solution of

$$y'' + p(x)y' + q(x)y = f_2(x)$$

on  $(a, b)$ . Then

$$y_p = y_{p_1} + y_{p_2}$$

is a particular solution of

$$y'' + p(x)y' + q(x)y = f_1(x) + f_2(x)$$

on  $(a, b)$ .

**Proof** If  $y_p = y_{p_1} + y_{p_2}$  then

$$\begin{aligned} y_p'' + p(x)y_p' + q(x)y_p &= (y_{p_1} + y_{p_2})'' + p(x)(y_{p_1} + y_{p_2})' + q(x)(y_{p_1} + y_{p_2}) \\ &= (y_{p_1}'' + p(x)y_{p_1}' + q(x)y_{p_1}) + (y_{p_2}'' + p(x)y_{p_2}' + q(x)y_{p_2}) \\ &= f_1(x) + f_2(x). \blacksquare \end{aligned}$$

It's easy to generalize Theorem 5.3.3 to the equation

$$y'' + p(x)y' + q(x)y = f(x) \tag{5.3.14}$$

where

$$f = f_1 + f_2 + \cdots + f_k;$$

thus, if  $y_{p_i}$  is a particular solution of

$$y'' + p(x)y' + q(x)y = f_i(x)$$

on  $(a, b)$  for  $i = 1, 2, \dots, k$ , then  $y_{p_1} + y_{p_2} + \cdots + y_{p_k}$  is a particular solution of (5.3.14) on  $(a, b)$ . Moreover, by a proof similar to the proof of Theorem 5.3.3 we can formulate the principle of superposition in terms of a linear equation written in the form

$$P_0(x)y'' + P_1(x)y' + P_2(x)y = F(x)$$

(Exercise 39); that is, if  $y_{p_1}$  is a particular solution of

$$P_0(x)y'' + P_1(x)y' + P_2(x)y = F_1(x)$$

on  $(a, b)$  and  $y_{p_2}$  is a particular solution of

$$P_0(x)y'' + P_1(x)y' + P_2(x)y = F_2(x)$$

on  $(a, b)$ , then  $y_{p_1} + y_{p_2}$  is a solution of

$$P_0(x)y'' + P_1(x)y' + P_2(x)y = F_1(x) + F_2(x)$$

on  $(a, b)$ .

**Example 5.3.4** The function  $y_{p_1} = x^4/15$  is a particular solution of

$$x^2y'' + 4xy' + 2y = 2x^4 \tag{5.3.15}$$

on  $(-\infty, \infty)$  and  $y_{p_2} = x^2/3$  is a particular solution of

$$x^2y'' + 4xy' + 2y = 4x^2 \tag{5.3.16}$$

on  $(-\infty, \infty)$ . Use the principle of superposition to find a particular solution of

$$x^2y'' + 4xy' + 2y = 2x^4 + 4x^2 \tag{5.3.17}$$

on  $(-\infty, \infty)$ .



**Solution** The right side  $F(x) = 2x^4 + 4x^2$  in (5.3.17) is the sum of the right sides

$$F_1(x) = 2x^4 \quad \text{and} \quad F_2(x) = 4x^2.$$

in (5.3.15) and (5.3.16). Therefore the principle of superposition implies that

$$y_p = y_{p_1} + y_{p_2} = \frac{x^4}{15} + \frac{x^2}{3}$$

is a particular solution of (5.3.17).

### 5.3 Exercises

In Exercises 1–6 find a particular solution by the method used in Example 5.3.2. Then find the general solution and, where indicated, solve the initial value problem and graph the solution.

- $y'' + 5y' - 6y = 22 + 18x - 18x^2$
- $y'' - 4y' + 5y = 1 + 5x$
- $y'' + 8y' + 7y = -8 - x + 24x^2 + 7x^3$
- $y'' - 4y' + 4y = 2 + 8x - 4x^2$
- C/G**  $y'' + 2y' + 10y = 4 + 26x + 6x^2 + 10x^3$ ,  $y(0) = 2$ ,  $y'(0) = 9$
- C/G**  $y'' + 6y' + 10y = 22 + 20x$ ,  $y(0) = 2$ ,  $y'(0) = -2$
- Show that the method used in Example 5.3.2 won't yield a particular solution of

$$y'' + y' = 1 + 2x + x^2; \tag{A}$$

that is, (A) does not have a particular solution of the form  $y_p = A + Bx + Cx^2$ , where  $A$ ,  $B$ , and  $C$  are constants.

In Exercises 8–13 find a particular solution by the method used in Example 5.3.3.

- $x^2y'' + 7xy' + 8y = \frac{6}{x}$
- $x^2y'' - 7xy' + 7y = 13x^{1/2}$
- $x^2y'' - xy' + y = 2x^3$
- $x^2y'' + 5xy' + 4y = \frac{1}{x^3}$
- $x^2y'' + xy' + y = 10x^{1/3}$
- $x^2y'' - 3xy' + 13y = 2x^4$
- Show that the method suggested for finding a particular solution in Exercises 8–13 won't yield a particular solution of

$$x^2y'' + 3xy' - 3y = \frac{1}{x^3}; \tag{A}$$

that is, (A) doesn't have a particular solution of the form  $y_p = A/x^3$ .

- Prove: If  $a$ ,  $b$ ,  $c$ ,  $\alpha$ , and  $M$  are constants and  $M \neq 0$  then

$$ax^2y'' + bxy' + cy = Mx^\alpha$$

has a particular solution  $y_p = Ax^\alpha$  ( $A = \text{constant}$ ) if and only if  $a\alpha(\alpha - 1) + b\alpha + c \neq 0$ .

If  $a$ ,  $b$ ,  $c$ , and  $\alpha$  are constants, then

$$a(e^{\alpha x})'' + b(e^{\alpha x})' + ce^{\alpha x} = (a\alpha^2 + b\alpha + c)e^{\alpha x}.$$

Use this in Exercises 16–21 to find a particular solution. Then find the general solution and, where indicated, solve the initial value problem and graph the solution.

16.  $y'' + 5y' - 6y = 6e^{3x}$

17.  $y'' - 4y' + 5y = e^{2x}$

18. C/G  $y'' + 8y' + 7y = 10e^{-2x}$ ,  $y(0) = -2$ ,  $y'(0) = 10$

19. C/G  $y'' - 4y' + 4y = e^x$ ,  $y(0) = 2$ ,  $y'(0) = 0$

20.  $y'' + 2y' + 10y = e^{x/2}$

21.  $y'' + 6y' + 10y = e^{-3x}$

22. Show that the method suggested for finding a particular solution in Exercises 16–21 won't yield a particular solution of

$$y'' - 7y' + 12y = 5e^{4x}; \quad (\text{A})$$

that is, (A) doesn't have a particular solution of the form  $y_p = Ae^{4x}$ .

23. Prove: If  $\alpha$  and  $M$  are constants and  $M \neq 0$  then constant coefficient equation

$$ay'' + by' + cy = Me^{\alpha x}$$

has a particular solution  $y_p = Ae^{\alpha x}$  ( $A = \text{constant}$ ) if and only if  $e^{\alpha x}$  isn't a solution of the complementary equation.

If  $\omega$  is a constant, differentiating a linear combination of  $\cos \omega x$  and  $\sin \omega x$  with respect to  $x$  yields another linear combination of  $\cos \omega x$  and  $\sin \omega x$ . In Exercises 24–29 use this to find a particular solution of the equation. Then find the general solution and, where indicated, solve the initial value problem and graph the solution.

24.  $y'' - 8y' + 16y = 23 \cos x - 7 \sin x$

25.  $y'' + y' = -8 \cos 2x + 6 \sin 2x$

26.  $y'' - 2y' + 3y = -6 \cos 3x + 6 \sin 3x$

27.  $y'' + 6y' + 13y = 18 \cos x + 6 \sin x$

28. C/G  $y'' + 7y' + 12y = -2 \cos 2x + 36 \sin 2x$ ,  $y(0) = -3$ ,  $y'(0) = 3$

29. C/G  $y'' - 6y' + 9y = 18 \cos 3x + 18 \sin 3x$ ,  $y(0) = 2$ ,  $y'(0) = 2$

30. Find the general solution of

$$y'' + \omega_0^2 y = M \cos \omega x + N \sin \omega x,$$

where  $M$  and  $N$  are constants and  $\omega$  and  $\omega_0$  are distinct positive numbers.

31. Show that the method suggested for finding a particular solution in Exercises 24–29 won't yield a particular solution of

$$y'' + y = \cos x + \sin x; \quad (\text{A})$$

that is, (A) does not have a particular solution of the form  $y_p = A \cos x + B \sin x$ .

32. Prove: If  $M, N$  are constants (not both zero) and  $\omega > 0$ , the constant coefficient equation

$$ay'' + by' + cy = M \cos \omega x + N \sin \omega x \quad (\text{A})$$

has a particular solution that's a linear combination of  $\cos \omega x$  and  $\sin \omega x$  if and only if the left side of (A) is not of the form  $a(y'' + \omega^2 y)$ , so that  $\cos \omega x$  and  $\sin \omega x$  are solutions of the complementary equation.

In Exercises 33–38 refer to the cited exercises and use the principal of superposition to find a particular solution. Then find the general solution.

33.  $y'' + 5y' - 6y = 22 + 18x - 18x^2 + 6e^{3x}$  (See Exercises 1 and 16.)  
 34.  $y'' - 4y' + 5y = 1 + 5x + e^{2x}$  (See Exercises 2 and 17.)  
 35.  $y'' + 8y' + 7y = -8 - x + 24x^2 + 7x^3 + 10e^{-2x}$  (See Exercises 3 and 18.)  
 36.  $y'' - 4y' + 4y = 2 + 8x - 4x^2 + e^x$  (See Exercises 4 and 19.)  
 37.  $y'' + 2y' + 10y = 4 + 26x + 6x^2 + 10x^3 + e^{x/2}$  (See Exercises 5 and 20.)  
 38.  $y'' + 6y' + 10y = 22 + 20x + e^{-3x}$  (See Exercises 6 and 21.)  
 39. Prove: If  $y_{p_1}$  is a particular solution of

$$P_0(x)y'' + P_1(x)y' + P_2(x)y = F_1(x)$$

on  $(a, b)$  and  $y_{p_2}$  is a particular solution of

$$P_0(x)y'' + P_1(x)y' + P_2(x)y = F_2(x)$$

on  $(a, b)$ , then  $y_p = y_{p_1} + y_{p_2}$  is a solution of

$$P_0(x)y'' + P_1(x)y' + P_2(x)y = F_1(x) + F_2(x)$$

on  $(a, b)$ .

40. Suppose  $p, q$ , and  $f$  are continuous on  $(a, b)$ . Let  $y_1, y_2$ , and  $y_p$  be twice differentiable on  $(a, b)$ , such that  $y = c_1 y_1 + c_2 y_2 + y_p$  is a solution of

$$y'' + p(x)y' + q(x)y = f$$

on  $(a, b)$  for every choice of the constants  $c_1, c_2$ . Show that  $y_1$  and  $y_2$  are solutions of the complementary equation on  $(a, b)$ .

## 5.4 THE METHOD OF UNDETERMINED COEFFICIENTS I

In this section we consider the constant coefficient equation

$$ay'' + by' + cy = e^{\alpha x} G(x), \quad (5.4.1)$$

where  $\alpha$  is a constant and  $G$  is a polynomial.

From Theorem 5.3.2, the general solution of (5.4.1) is  $y = y_p + c_1 y_1 + c_2 y_2$ , where  $y_p$  is a particular solution of (5.4.1) and  $\{y_1, y_2\}$  is a fundamental set of solutions of the complementary equation

$$ay'' + by' + cy = 0.$$

In Section 5.2 we showed how to find  $\{y_1, y_2\}$ . In this section we'll show how to find  $y_p$ . The procedure that we'll use is called *the method of undetermined coefficients*.

Our first example is similar to Exercises 16–21.

**Example 5.4.1** Find a particular solution of

$$y'' - 7y' + 12y = 4e^{2x}. \quad (5.4.2)$$

Then find the general solution.

**Solution** Substituting  $y_p = Ae^{2x}$  for  $y$  in (5.4.2) will produce a constant multiple of  $Ae^{2x}$  on the left side of (5.4.2), so it may be possible to choose  $A$  so that  $y_p$  is a solution of (5.4.2). Let's try it; if  $y_p = Ae^{2x}$  then

$$y_p'' - 7y_p' + 12y_p = 4Ae^{2x} - 14Ae^{2x} + 12Ae^{2x} = 2Ae^{2x} = 4e^{2x}$$

if  $A = 2$ . Therefore  $y_p = 2e^{2x}$  is a particular solution of (5.4.2). To find the general solution, we note that the characteristic polynomial of the complementary equation

$$y'' - 7y' + 12y = 0 \quad (5.4.3)$$

is  $p(r) = r^2 - 7r + 12 = (r - 3)(r - 4)$ , so  $\{e^{3x}, e^{4x}\}$  is a fundamental set of solutions of (5.4.3). Therefore the general solution of (5.4.2) is

$$y = 2e^{2x} + c_1e^{3x} + c_2e^{4x}.$$

**Example 5.4.2** Find a particular solution of

$$y'' - 7y' + 12y = 5e^{4x}. \quad (5.4.4)$$

Then find the general solution.

**Solution** Fresh from our success in finding a particular solution of (5.4.2) — where we chose  $y_p = Ae^{2x}$  because the right side of (5.4.2) is a constant multiple of  $e^{2x}$  — it may seem reasonable to try  $y_p = Ae^{4x}$  as a particular solution of (5.4.4). However, this won't work, since we saw in Example 5.4.1 that  $e^{4x}$  is a solution of the complementary equation (5.4.3), so substituting  $y_p = Ae^{4x}$  into the left side of (5.4.4) produces zero on the left, no matter how we choose  $A$ . To discover a suitable form for  $y_p$ , we use the same approach that we used in Section 5.2 to find a second solution of

$$ay'' + by' + cy = 0$$

in the case where the characteristic equation has a repeated real root: we look for solutions of (5.4.4) in the form  $y = ue^{4x}$ , where  $u$  is a function to be determined. Substituting

$$y = ue^{4x}, \quad y' = u'e^{4x} + 4ue^{4x}, \quad \text{and} \quad y'' = u''e^{4x} + 8u'e^{4x} + 16ue^{4x} \quad (5.4.5)$$

into (5.4.4) and canceling the common factor  $e^{4x}$  yields

$$(u'' + 8u' + 16u) - 7(u' + 4u) + 12u = 5,$$

or

$$u'' + u' = 5.$$

By inspection we see that  $u_p = 5x$  is a particular solution of this equation, so  $y_p = 5xe^{4x}$  is a particular solution of (5.4.4). Therefore

$$y = 5xe^{4x} + c_1e^{3x} + c_2e^{4x}$$

is the general solution.

**Example 5.4.3** Find a particular solution of

$$y'' - 8y' + 16y = 2e^{4x}. \quad (5.4.6)$$

**Solution** Since the characteristic polynomial of the complementary equation

$$y'' - 8y' + 16y = 0 \quad (5.4.7)$$

is  $p(r) = r^2 - 8r + 16 = (r - 4)^2$ , both  $y_1 = e^{4x}$  and  $y_2 = xe^{4x}$  are solutions of (5.4.7). Therefore (5.4.6) does not have a solution of the form  $y_p = Ae^{4x}$  or  $y_p = Axe^{4x}$ . As in Example 5.4.2, we look for solutions of (5.4.6) in the form  $y = ue^{4x}$ , where  $u$  is a function to be determined. Substituting from (5.4.5) into (5.4.6) and canceling the common factor  $e^{4x}$  yields

$$(u'' + 8u' + 16u) - 8(u' + 4u) + 16u = 2,$$

or

$$u'' = 2.$$

Integrating twice and taking the constants of integration to be zero shows that  $u_p = x^2$  is a particular solution of this equation, so  $y_p = x^2e^{4x}$  is a particular solution of (5.4.4). Therefore

$$y = e^{4x}(x^2 + c_1 + c_2x)$$

is the general solution. ■

The preceding examples illustrate the following facts concerning the form of a particular solution  $y_p$  of a constant coefficient equation

$$ay'' + by' + cy = ke^{\alpha x},$$

where  $k$  is a nonzero constant:

(a) If  $e^{\alpha x}$  isn't a solution of the complementary equation

$$ay'' + by' + cy = 0, \quad (5.4.8)$$

then  $y_p = Ae^{\alpha x}$ , where  $A$  is a constant. (See Example 5.4.1).

(b) If  $e^{\alpha x}$  is a solution of (5.4.8) but  $xe^{\alpha x}$  is not, then  $y_p = Axe^{\alpha x}$ , where  $A$  is a constant. (See Example 5.4.2.)

(c) If both  $e^{\alpha x}$  and  $xe^{\alpha x}$  are solutions of (5.4.8), then  $y_p = Ax^2e^{\alpha x}$ , where  $A$  is a constant. (See Example 5.4.3.)

See Exercise 30 for the proofs of these facts.

In all three cases you can just substitute the appropriate form for  $y_p$  and its derivatives directly into

$$ay_p'' + by_p' + cy_p = ke^{\alpha x},$$

and solve for the constant  $A$ , as we did in Example 5.4.1. (See Exercises 31–33.) However, if the equation is

$$ay'' + by' + cy = ke^{\alpha x}G(x),$$

where  $G$  is a polynomial of degree greater than zero, we recommend that you use the substitution  $y = ue^{\alpha x}$  as we did in Examples 5.4.2 and 5.4.3. The equation for  $u$  will turn out to be

$$au'' + p'(\alpha)u' + p(\alpha)u = G(x), \quad (5.4.9)$$

where  $p(r) = ar^2 + br + c$  is the characteristic polynomial of the complementary equation and  $p'(r) = 2ar + b$  (Exercise 30); however, you shouldn't memorize this since it's easy to derive the equation for  $u$  in any particular case. Note, however, that if  $e^{\alpha x}$  is a solution of the complementary equation then  $p(\alpha) = 0$ , so (5.4.9) reduces to

$$au'' + p'(\alpha)u' = G(x),$$

while if both  $e^{\alpha x}$  and  $xe^{\alpha x}$  are solutions of the complementary equation then  $p(r) = a(r - \alpha)^2$  and  $p'(r) = 2a(r - \alpha)$ , so  $p(\alpha) = p'(\alpha) = 0$  and (5.4.9) reduces to

$$au'' = G(x).$$

**Example 5.4.4** Find a particular solution of

$$y'' - 3y' + 2y = e^{3x}(-1 + 2x + x^2). \quad (5.4.10)$$

**Solution** Substituting

$$y = ue^{3x}, \quad y' = u'e^{3x} + 3ue^{3x}, \quad \text{and } y'' = u''e^{3x} + 6u'e^{3x} + 9ue^{3x}$$

into (5.4.10) and canceling  $e^{3x}$  yields

$$(u'' + 6u' + 9u) - 3(u' + 3u) + 2u = -1 + 2x + x^2,$$

or

$$u'' + 3u' + 2u = -1 + 2x + x^2. \quad (5.4.11)$$

As in Example 2, in order to guess a form for a particular solution of (5.4.11), we note that substituting a second degree polynomial  $u_p = A + Bx + Cx^2$  for  $u$  in the left side of (5.4.11) produces another second degree polynomial with coefficients that depend upon  $A$ ,  $B$ , and  $C$ ; thus,

$$\text{if } u_p = A + Bx + Cx^2 \quad \text{then } u'_p = B + 2Cx \quad \text{and } u''_p = 2C.$$

If  $u_p$  is to satisfy (5.4.11), we must have

$$\begin{aligned} u''_p + 3u'_p + 2u_p &= 2C + 3(B + 2Cx) + 2(A + Bx + Cx^2) \\ &= (2C + 3B + 2A) + (6C + 2B)x + 2Cx^2 = -1 + 2x + x^2. \end{aligned}$$

Equating coefficients of like powers of  $x$  on the two sides of the last equality yields

$$\begin{aligned} 2C &= 1 \\ 2B + 6C &= 2 \\ 2A + 3B + 2C &= -1. \end{aligned}$$

Solving these equations for  $C$ ,  $B$ , and  $A$  (in that order) yields  $C = 1/2$ ,  $B = -1/2$ ,  $A = -1/4$ . Therefore

$$u_p = -\frac{1}{4}(1 + 2x - 2x^2)$$

is a particular solution of (5.4.11), and

$$y_p = u_p e^{3x} = -\frac{e^{3x}}{4}(1 + 2x - 2x^2)$$

is a particular solution of (5.4.10).

**Example 5.4.5** Find a particular solution of

$$y'' - 4y' + 3y = e^{3x}(6 + 8x + 12x^2). \quad (5.4.12)$$

**Solution** Substituting

$$y = ue^{3x}, \quad y' = u'e^{3x} + 3ue^{3x}, \quad \text{and} \quad y'' = u''e^{3x} + 6u'e^{3x} + 9ue^{3x}$$

into (5.4.12) and canceling  $e^{3x}$  yields

$$(u'' + 6u' + 9u) - 4(u' + 3u) + 3u = 6 + 8x + 12x^2,$$

or

$$u'' + 2u' = 6 + 8x + 12x^2. \quad (5.4.13)$$

There's no  $u$  term in this equation, since  $e^{3x}$  is a solution of the complementary equation for (5.4.12). (See Exercise 30.) Therefore (5.4.13) does not have a particular solution of the form  $u_p = A + Bx + Cx^2$  that we used successfully in Example 5.4.4, since with this choice of  $u_p$ ,

$$u_p'' + 2u_p' = 2C + (B + 2Cx)$$

can't contain the last term ( $12x^2$ ) on the right side of (5.4.13). Instead, let's try  $u_p = Ax + Bx^2 + Cx^3$  on the grounds that

$$u_p' = A + 2Bx + 3Cx^2 \quad \text{and} \quad u_p'' = 2B + 6Cx$$

together contain all the powers of  $x$  that appear on the right side of (5.4.13).

Substituting these expressions in place of  $u'$  and  $u''$  in (5.4.13) yields

$$(2B + 6Cx) + 2(A + 2Bx + 3Cx^2) = (2B + 2A) + (6C + 4B)x + 6Cx^2 = 6 + 8x + 12x^2.$$

Comparing coefficients of like powers of  $x$  on the two sides of the last equality shows that  $u_p$  satisfies (5.4.13) if

$$\begin{aligned} 6C &= 12 \\ 4B + 6C &= 8 \\ 2A + 2B &= 6. \end{aligned}$$

Solving these equations successively yields  $C = 2$ ,  $B = -1$ , and  $A = 4$ . Therefore

$$u_p = x(4 - x + 2x^2)$$

is a particular solution of (5.4.13), and

$$y_p = u_p e^{3x} = x e^{3x} (4 - x + 2x^2)$$

is a particular solution of (5.4.12).

**Example 5.4.6** Find a particular solution of

$$4y'' + 4y' + y = e^{-x/2}(-8 + 48x + 144x^2). \quad (5.4.14)$$

**Solution** Substituting

$$y = ue^{-x/2}, \quad y' = u'e^{-x/2} - \frac{1}{2}ue^{-x/2}, \quad \text{and} \quad y'' = u''e^{-x/2} - u'e^{-x/2} + \frac{1}{4}ue^{-x/2}$$

into (5.4.14) and canceling  $e^{-x/2}$  yields

$$4\left(u'' - u' + \frac{u}{4}\right) + 4\left(u' - \frac{u}{2}\right) + u = 4u'' = -8 + 48x + 144x^2,$$

or

$$u'' = -2 + 12x + 36x^2, \quad (5.4.15)$$

which does not contain  $u$  or  $u'$  because  $e^{-x/2}$  and  $xe^{-x/2}$  are both solutions of the complementary equation. (See Exercise 30.) To obtain a particular solution of (5.4.15) we integrate twice, taking the constants of integration to be zero; thus,

$$u'_p = -2x + 6x^2 + 12x^3 \quad \text{and} \quad u_p = -x^2 + 2x^3 + 3x^4 = x^2(-1 + 2x + 3x^2).$$

Therefore

$$y_p = u_p e^{-x/2} = x^2 e^{-x/2} (-1 + 2x + 3x^2)$$

is a particular solution of (5.4.14).

### Summary

The preceding examples illustrate the following facts concerning particular solutions of a constant coefficient equation of the form

$$ay'' + by' + cy = e^{\alpha x} G(x),$$

where  $G$  is a polynomial (see Exercise 30):

(a) If  $e^{\alpha x}$  isn't a solution of the complementary equation

$$ay'' + by' + cy = 0, \quad (5.4.16)$$

then  $y_p = e^{\alpha x} Q(x)$ , where  $Q$  is a polynomial of the same degree as  $G$ . (See Example 5.4.4.)

(b) If  $e^{\alpha x}$  is a solution of (5.4.16) but  $xe^{\alpha x}$  is not, then  $y_p = xe^{\alpha x} Q(x)$ , where  $Q$  is a polynomial of the same degree as  $G$ . (See Example 5.4.5.)

(c) If both  $e^{\alpha x}$  and  $xe^{\alpha x}$  are solutions of (5.4.16), then  $y_p = x^2 e^{\alpha x} Q(x)$ , where  $Q$  is a polynomial of the same degree as  $G$ . (See Example 5.4.6.)

In all three cases, you can just substitute the appropriate form for  $y_p$  and its derivatives directly into

$$ay''_p + by'_p + cy_p = e^{\alpha x} G(x),$$

and solve for the coefficients of the polynomial  $Q$ . However, if you try this you will see that the computations are more tedious than those that you encounter by making the substitution  $y = ue^{\alpha x}$  and finding a particular solution of the resulting equation for  $u$ . (See Exercises 34-36.) In Case (a) the equation for  $u$  will be of the form

$$au'' + p'(\alpha)u' + p(\alpha)u = G(x),$$

with a particular solution of the form  $u_p = Q(x)$ , a polynomial of the same degree as  $G$ , whose coefficients can be found by the method used in Example 5.4.4. In Case (b) the equation for  $u$  will be of the form

$$au'' + p'(\alpha)u' = G(x)$$

(no  $u$  term on the left), with a particular solution of the form  $u_p = xQ(x)$ , where  $Q$  is a polynomial of the same degree as  $G$  whose coefficients can be found by the method used in Example 5.4.5. In Case (c) the equation for  $u$  will be of the form

$$au'' = G(x)$$



with a particular solution of the form  $u_p = x^2Q(x)$  that can be obtained by integrating  $G(x)/a$  twice and taking the constants of integration to be zero, as in Example 5.4.6.

### Using the Principle of Superposition

The next example shows how to combine the method of undetermined coefficients and Theorem 5.3.3, the principle of superposition.

**Example 5.4.7** Find a particular solution of

$$y'' - 7y' + 12y = 4e^{2x} + 5e^{4x}. \quad (5.4.17)$$

**Solution** In Example 5.4.1 we found that  $y_{p_1} = 2e^{2x}$  is a particular solution of

$$y'' - 7y' + 12y = 4e^{2x},$$

and in Example 5.4.2 we found that  $y_{p_2} = 5xe^{4x}$  is a particular solution of

$$y'' - 7y' + 12y = 5e^{4x}.$$

Therefore the principle of superposition implies that  $y_p = 2e^{2x} + 5xe^{4x}$  is a particular solution of (5.4.17).

## 5.4 Exercises

---

In Exercises 1–14 find a particular solution.

1.  $y'' - 3y' + 2y = e^{3x}(1 + x)$
2.  $y'' - 6y' + 5y = e^{-3x}(35 - 8x)$
3.  $y'' - 2y' - 3y = e^x(-8 + 3x)$
4.  $y'' + 2y' + y = e^{2x}(-7 - 15x + 9x^2)$
5.  $y'' + 4y = e^{-x}(7 - 4x + 5x^2)$
6.  $y'' - y' - 2y = e^x(9 + 2x - 4x^2)$
7.  $y'' - 4y' - 5y = -6xe^{-x}$
8.  $y'' - 3y' + 2y = e^x(3 - 4x)$
9.  $y'' + y' - 12y = e^{3x}(-6 + 7x)$
10.  $2y'' - 3y' - 2y = e^{2x}(-6 + 10x)$
11.  $y'' + 2y' + y = e^{-x}(2 + 3x)$
12.  $y'' - 2y' + y = e^x(1 - 6x)$
13.  $y'' - 4y' + 4y = e^{2x}(1 - 3x + 6x^2)$
14.  $9y'' + 6y' + y = e^{-x/3}(2 - 4x + 4x^2)$

In Exercises 15–19 find the general solution.

15.  $y'' - 3y' + 2y = e^{3x}(1 + x)$
16.  $y'' - 6y' + 8y = e^x(11 - 6x)$
17.  $y'' + 6y' + 9y = e^{2x}(3 - 5x)$
18.  $y'' + 2y' - 3y = -16xe^x$
19.  $y'' - 2y' + y = e^x(2 - 12x)$

In Exercises 20–23 solve the initial value problem and plot the solution.

20. C/G  $y'' - 4y' - 5y = 9e^{2x}(1+x), \quad y(0) = 0, \quad y'(0) = -10$

21. C/G  $y'' + 3y' - 4y = e^{2x}(7+6x), \quad y(0) = 2, \quad y'(0) = 8$

22. C/G  $y'' + 4y' + 3y = -e^{-x}(2+8x), \quad y(0) = 1, \quad y'(0) = 2$

23. C/G  $y'' - 3y' - 10y = 7e^{-2x}, \quad y(0) = 1, \quad y'(0) = -17$

In Exercises 24–29 use the principle of superposition to find a particular solution.

24.  $y'' + y' + y = xe^x + e^{-x}(1+2x)$

25.  $y'' - 7y' + 12y = -e^x(17-42x) - e^{3x}$

26.  $y'' - 8y' + 16y = 6xe^{4x} + 2 + 16x + 16x^2$

27.  $y'' - 3y' + 2y = -e^{2x}(3+4x) - e^x$

28.  $y'' - 2y' + 2y = e^x(1+x) + e^{-x}(2-8x+5x^2)$

29.  $y'' + y = e^{-x}(2-4x+2x^2) + e^{3x}(8-12x-10x^2)$

30. (a) Prove that  $y$  is a solution of the constant coefficient equation

$$ay'' + by' + cy = e^{\alpha x}G(x) \quad (\text{A})$$

if and only if  $y = ue^{\alpha x}$ , where  $u$  satisfies

$$au'' + p'(\alpha)u' + p(\alpha)u = G(x) \quad (\text{B})$$

and  $p(r) = ar^2 + br + c$  is the characteristic polynomial of the complementary equation

$$ay'' + by' + cy = 0.$$

For the rest of this exercise, let  $G$  be a polynomial. Give the requested proofs for the case where

$$G(x) = g_0 + g_1x + g_2x^2 + g_3x^3.$$

- (b) Prove that if  $e^{\alpha x}$  isn't a solution of the complementary equation then (B) has a particular solution of the form  $u_p = A(x)$ , where  $A$  is a polynomial of the same degree as  $G$ , as in Example 5.4.4. Conclude that (A) has a particular solution of the form  $y_p = e^{\alpha x}A(x)$ .
- (c) Show that if  $e^{\alpha x}$  is a solution of the complementary equation and  $xe^{\alpha x}$  isn't, then (B) has a particular solution of the form  $u_p = xA(x)$ , where  $A$  is a polynomial of the same degree as  $G$ , as in Example 5.4.5. Conclude that (A) has a particular solution of the form  $y_p = xe^{\alpha x}A(x)$ .
- (d) Show that if  $e^{\alpha x}$  and  $xe^{\alpha x}$  are both solutions of the complementary equation then (B) has a particular solution of the form  $u_p = x^2A(x)$ , where  $A$  is a polynomial of the same degree as  $G$ , and  $x^2A(x)$  can be obtained by integrating  $G/a$  twice, taking the constants of integration to be zero, as in Example 5.4.6. Conclude that (A) has a particular solution of the form  $y_p = x^2e^{\alpha x}A(x)$ .

Exercises 31–36 treat the equations considered in Examples 5.4.1–5.4.6. Substitute the suggested form of  $y_p$  into the equation and equate the resulting coefficients of like functions on the two sides of the resulting equation to derive a set of simultaneous equations for the coefficients in  $y_p$ . Then solve for the coefficients to obtain  $y_p$ . Compare the work you've done with the work required to obtain the same results in Examples 5.4.1–5.4.6.

31. Compare with Example 5.4.1:

$$y'' - 7y' + 12y = 4e^{2x}; \quad y_p = Ae^{2x}$$

32. Compare with Example 5.4.2:

$$y'' - 7y' + 12y = 5e^{4x}; \quad y_p = Axe^{4x}$$

33. Compare with Example 5.4.3:

$$y'' - 8y' + 16y = 2e^{4x}; \quad y_p = Ax^2e^{4x}$$

34. Compare with Example 5.4.4:

$$y'' - 3y' + 2y = e^{3x}(-1 + 2x + x^2), \quad y_p = e^{3x}(A + Bx + Cx^2)$$

35. Compare with Example 5.4.5:

$$y'' - 4y' + 3y = e^{3x}(6 + 8x + 12x^2), \quad y_p = e^{3x}(Ax + Bx^2 + Cx^3)$$

36. Compare with Example 5.4.6:

$$4y'' + 4y' + y = e^{-x/2}(-8 + 48x + 144x^2), \quad y_p = e^{-x/2}(Ax^2 + Bx^3 + Cx^4)$$

37. Write
- $y = ue^{\alpha x}$
- to find the general solution.

$$(a) \quad y'' + 2y' + y = \frac{e^{-x}}{\sqrt{x}}$$

$$(b) \quad y'' + 6y' + 9y = e^{-3x} \ln x$$

$$(c) \quad y'' - 4y' + 4y = \frac{e^{2x}}{1+x}$$

$$(d) \quad 4y'' + 4y' + y = 4e^{-x/2} \left( \frac{1}{x} + x \right)$$

38. Suppose
- $\alpha \neq 0$
- and
- $k$
- is a positive integer. In most calculus books integrals like
- $\int x^k e^{\alpha x} dx$
- are evaluated by integrating by parts
- $k$
- times. This exercise presents another method. Let

$$y = \int e^{\alpha x} P(x) dx$$

with

$$P(x) = p_0 + p_1x + \cdots + p_kx^k, \quad (\text{where } p_k \neq 0).$$

- (a) Show that
- $y = e^{\alpha x}u$
- , where

$$u' + \alpha u = P(x). \tag{A}$$

- (b) Show that (A) has a particular solution of the form

$$u_p = A_0 + A_1x + \cdots + A_kx^k,$$

where  $A_k, A_{k-1}, \dots, A_0$  can be computed successively by equating coefficients of  $x^k, x^{k-1}, \dots, 1$  on both sides of the equation

$$u_p' + \alpha u_p = P(x).$$

- (c) Conclude that

$$\int e^{\alpha x} P(x) dx = (A_0 + A_1x + \cdots + A_kx^k) e^{\alpha x} + c,$$

where  $c$  is a constant of integration.

39. Use the method of Exercise 38 to evaluate the integral.

(a)  $\int e^x(4+x) dx$

(b)  $\int e^{-x}(-1+x^2) dx$

(c)  $\int x^3e^{-2x} dx$

(d)  $\int e^x(1+x)^2 dx$

(e)  $\int e^{3x}(-14+30x+27x^2) dx$

(f)  $\int e^{-x}(1+6x^2-14x^3+3x^4) dx$

40. Use the method suggested in Exercise 38 to evaluate  $\int x^k e^{\alpha x} dx$ , where  $k$  is an arbitrary positive integer and  $\alpha \neq 0$ .

## 5.5 THE METHOD OF UNDETERMINED COEFFICIENTS II

In this section we consider the constant coefficient equation

$$ay'' + by' + cy = e^{\lambda x} (P(x) \cos \omega x + Q(x) \sin \omega x) \quad (5.5.1)$$

where  $\lambda$  and  $\omega$  are real numbers,  $\omega \neq 0$ , and  $P$  and  $Q$  are polynomials. We want to find a particular solution of (5.5.1). As in Section 5.4, the procedure that we will use is called *the method of undetermined coefficients*.

### Forcing Functions Without Exponential Factors

We begin with the case where  $\lambda = 0$  in (5.5.1); thus, we want to find a particular solution of

$$ay'' + by' + cy = P(x) \cos \omega x + Q(x) \sin \omega x, \quad (5.5.2)$$

where  $P$  and  $Q$  are polynomials.

Differentiating  $x^r \cos \omega x$  and  $x^r \sin \omega x$  yields

$$\frac{d}{dx} x^r \cos \omega x = -\omega x^r \sin \omega x + r x^{r-1} \cos \omega x$$

and

$$\frac{d}{dx} x^r \sin \omega x = \omega x^r \cos \omega x + r x^{r-1} \sin \omega x.$$

This implies that if

$$y_p = A(x) \cos \omega x + B(x) \sin \omega x$$

where  $A$  and  $B$  are polynomials, then

$$ay_p'' + by_p' + cy_p = F(x) \cos \omega x + G(x) \sin \omega x,$$

where  $F$  and  $G$  are polynomials with coefficients that can be expressed in terms of the coefficients of  $A$  and  $B$ . This suggests that we try to choose  $A$  and  $B$  so that  $F = P$  and  $G = Q$ , respectively. Then  $y_p$  will be a particular solution of (5.5.2). The next theorem tells us how to choose the proper form for  $y_p$ . For the proof see Exercise 37.

**Theorem 5.5.1** *Suppose  $\omega$  is a positive number and  $P$  and  $Q$  are polynomials. Let  $k$  be the larger of the degrees of  $P$  and  $Q$ . Then the equation*

$$ay'' + by' + cy = P(x) \cos \omega x + Q(x) \sin \omega x$$

*has a particular solution*

$$y_p = A(x) \cos \omega x + B(x) \sin \omega x, \quad (5.5.3)$$

where

$$A(x) = A_0 + A_1x + \cdots + A_kx^k \quad \text{and} \quad B(x) = B_0 + B_1x + \cdots + B_kx^k,$$

provided that  $\cos \omega x$  and  $\sin \omega x$  are not solutions of the complementary equation. The solutions of

$$a(y'' + \omega^2 y) = P(x) \cos \omega x + Q(x) \sin \omega x$$

(for which  $\cos \omega x$  and  $\sin \omega x$  are solutions of the complementary equation) are of the form (5.5.3), where

$$A(x) = A_0x + A_1x^2 + \cdots + A_kx^{k+1} \quad \text{and} \quad B(x) = B_0x + B_1x^2 + \cdots + B_kx^{k+1}.$$

For an analog of this theorem that's applicable to (5.5.1), see Exercise 38.

**Example 5.5.1** Find a particular solution of

$$y'' - 2y' + y = 5 \cos 2x + 10 \sin 2x. \quad (5.5.4)$$

**Solution** In (5.5.4) the coefficients of  $\cos 2x$  and  $\sin 2x$  are both zero degree polynomials (constants). Therefore Theorem 5.5.1 implies that (5.5.4) has a particular solution

$$y_p = A \cos 2x + B \sin 2x.$$

Since

$$y_p' = -2A \sin 2x + 2B \cos 2x \quad \text{and} \quad y_p'' = -4(A \cos 2x + B \sin 2x),$$

replacing  $y$  by  $y_p$  in (5.5.4) yields

$$\begin{aligned} y_p'' - 2y_p' + y_p &= -4(A \cos 2x + B \sin 2x) - 4(-A \sin 2x + B \cos 2x) \\ &\quad + (A \cos 2x + B \sin 2x) \\ &= (-3A - 4B) \cos 2x + (4A - 3B) \sin 2x. \end{aligned}$$

Equating the coefficients of  $\cos 2x$  and  $\sin 2x$  here with the corresponding coefficients on the right side of (5.5.4) shows that  $y_p$  is a solution of (5.5.4) if

$$\begin{aligned} -3A - 4B &= 5 \\ 4A - 3B &= 10. \end{aligned}$$

Solving these equations yields  $A = 1$ ,  $B = -2$ . Therefore

$$y_p = \cos 2x - 2 \sin 2x$$

is a particular solution of (5.5.4).

**Example 5.5.2** Find a particular solution of

$$y'' + 4y = 8 \cos 2x + 12 \sin 2x. \quad (5.5.5)$$

**Solution** The procedure used in Example 5.5.1 doesn't work here; substituting  $y_p = A \cos 2x + B \sin 2x$  for  $y$  in (5.5.5) yields

$$y_p'' + 4y_p = -4(A \cos 2x + B \sin 2x) + 4(A \cos 2x + B \sin 2x) = 0$$

for any choice of  $A$  and  $B$ , since  $\cos 2x$  and  $\sin 2x$  are both solutions of the complementary equation for (5.5.5). We're dealing with the second case mentioned in Theorem 5.5.1, and should therefore try a particular solution of the form

$$y_p = x(A \cos 2x + B \sin 2x). \quad (5.5.6)$$

Then

$$y'_p = A \cos 2x + B \sin 2x + 2x(-A \sin 2x + B \cos 2x)$$

and

$$\begin{aligned} y''_p &= -4A \sin 2x + 4B \cos 2x - 4x(A \cos 2x + B \sin 2x) \\ &= -4A \sin 2x + 4B \cos 2x - 4y_p \text{ (see (5.5.6)),} \end{aligned}$$

so

$$y''_p + 4y_p = -4A \sin 2x + 4B \cos 2x.$$

Therefore  $y_p$  is a solution of (5.5.5) if

$$-4A \sin 2x + 4B \cos 2x = 8 \cos 2x + 12 \sin 2x,$$

which holds if  $A = -3$  and  $B = 2$ . Therefore

$$y_p = -x(3 \cos 2x - 2 \sin 2x)$$

is a particular solution of (5.5.5).

**Example 5.5.3** Find a particular solution of

$$y'' + 3y' + 2y = (16 + 20x) \cos x + 10 \sin x. \quad (5.5.7)$$

**Solution** The coefficients of  $\cos x$  and  $\sin x$  in (5.5.7) are polynomials of degree one and zero, respectively. Therefore Theorem 5.5.1 tells us to look for a particular solution of (5.5.7) of the form

$$y_p = (A_0 + A_1x) \cos x + (B_0 + B_1x) \sin x. \quad (5.5.8)$$

Then

$$y'_p = (A_1 + B_0 + B_1x) \cos x + (B_1 - A_0 - A_1x) \sin x \quad (5.5.9)$$

and

$$y''_p = (2B_1 - A_0 - A_1x) \cos x - (2A_1 + B_0 + B_1x) \sin x, \quad (5.5.10)$$

so

$$\begin{aligned} y''_p + 3y'_p + 2y_p &= [A_0 + 3A_1 + 3B_0 + 2B_1 + (A_1 + 3B_1)x] \cos x \\ &\quad + [B_0 + 3B_1 - 3A_0 - 2A_1 + (B_1 - 3A_1)x] \sin x. \end{aligned} \quad (5.5.11)$$

Comparing the coefficients of  $x \cos x$ ,  $x \sin x$ ,  $\cos x$ , and  $\sin x$  here with the corresponding coefficients in (5.5.7) shows that  $y_p$  is a solution of (5.5.7) if

$$\begin{aligned} A_1 + 3B_1 &= 20 \\ -3A_1 + B_1 &= 0 \\ A_0 + 3B_0 + 3A_1 + 2B_1 &= 16 \\ -3A_0 + B_0 - 2A_1 + 3B_1 &= 10. \end{aligned}$$

Solving the first two equations yields  $A_1 = 2$ ,  $B_1 = 6$ . Substituting these into the last two equations yields

$$\begin{aligned} A_0 + 3B_0 &= 16 - 3A_1 - 2B_1 = -2 \\ -3A_0 + B_0 &= 10 + 2A_1 - 3B_1 = -4. \end{aligned}$$

Solving these equations yields  $A_0 = 1$ ,  $B_0 = -1$ . Substituting  $A_0 = 1$ ,  $A_1 = 2$ ,  $B_0 = -1$ ,  $B_1 = 6$  into (5.5.8) shows that

$$y_p = (1 + 2x) \cos x - (1 - 6x) \sin x$$

is a particular solution of (5.5.7).

#### A Useful Observation

In (5.5.9), (5.5.10), and (5.5.11) the polynomials multiplying  $\sin x$  can be obtained by replacing  $A_0, A_1, B_0$ , and  $B_1$  by  $B_0, B_1, -A_0$ , and  $-A_1$ , respectively, in the polynomials multiplying  $\cos x$ . An analogous result applies in general, as follows (Exercise 36).

#### Theorem 5.5.2 If

$$y_p = A(x) \cos \omega x + B(x) \sin \omega x,$$

where  $A(x)$  and  $B(x)$  are polynomials with coefficients  $A_0, \dots, A_k$  and  $B_0, \dots, B_k$ , then the polynomials multiplying  $\sin \omega x$  in

$$y_p', \quad y_p'', \quad ay_p'' + by_p' + cy_p \quad \text{and} \quad y_p'' + \omega^2 y_p$$

can be obtained by replacing  $A_0, \dots, A_k$  by  $B_0, \dots, B_k$  and  $B_0, \dots, B_k$  by  $-A_0, \dots, -A_k$  in the corresponding polynomials multiplying  $\cos \omega x$ .

We won't use this theorem in our examples, but we recommend that you use it to check your manipulations when you work the exercises.

**Example 5.5.4** Find a particular solution of

$$y'' + y = (8 - 4x) \cos x - (8 + 8x) \sin x. \quad (5.5.12)$$

**Solution** According to Theorem 5.5.1, we should look for a particular solution of the form

$$y_p = (A_0x + A_1x^2) \cos x + (B_0x + B_1x^2) \sin x, \quad (5.5.13)$$

since  $\cos x$  and  $\sin x$  are solutions of the complementary equation. However, let's try

$$y_p = (A_0 + A_1x) \cos x + (B_0 + B_1x) \sin x \quad (5.5.14)$$

first, so you can see why it doesn't work. From (5.5.10),

$$y_p'' = (2B_1 - A_0 - A_1x) \cos x - (2A_1 + B_0 + B_1x) \sin x,$$

which together with (5.5.14) implies that

$$y_p'' + y_p = 2B_1 \cos x - 2A_1 \sin x.$$

Since the right side of this equation does not contain  $x \cos x$  or  $x \sin x$ , (5.5.14) can't satisfy (5.5.12) no matter how we choose  $A_0, A_1, B_0$ , and  $B_1$ .

Now let  $y_p$  be as in (5.5.13). Then

$$\begin{aligned} y_p' &= [A_0 + (2A_1 + B_0)x + B_1x^2] \cos x \\ &\quad + [B_0 + (2B_1 - A_0)x - A_1x^2] \sin x \\ \text{and } y_p'' &= [2A_1 + 2B_0 - (A_0 - 4B_1)x - A_1x^2] \cos x \\ &\quad + [2B_1 - 2A_0 - (B_0 + 4A_1)x - B_1x^2] \sin x, \end{aligned}$$

so

$$y_p'' + y_p = (2A_1 + 2B_0 + 4B_1x) \cos x + (2B_1 - 2A_0 - 4A_1x) \sin x.$$

Comparing the coefficients of  $\cos x$  and  $\sin x$  here with the corresponding coefficients in (5.5.12) shows that  $y_p$  is a solution of (5.5.12) if

$$\begin{aligned} 4B_1 &= -4 \\ -4A_1 &= -8 \\ 2B_0 + 2A_1 &= 8 \\ -2A_0 + 2B_1 &= -8. \end{aligned}$$

The solution of this system is  $A_1 = 2$ ,  $B_1 = -1$ ,  $A_0 = 3$ ,  $B_0 = 2$ . Therefore

$$y_p = x [(3 + 2x) \cos x + (2 - x) \sin x]$$

is a particular solution of (5.5.12).

### Forcing Functions with Exponential Factors

To find a particular solution of

$$ay'' + by' + cy = e^{\lambda x} (P(x) \cos \omega x + Q(x) \sin \omega x) \quad (5.5.15)$$

when  $\lambda \neq 0$ , we recall from Section 5.4 that substituting  $y = ue^{\lambda x}$  into (5.5.15) will produce a constant coefficient equation for  $u$  with the forcing function  $P(x) \cos \omega x + Q(x) \sin \omega x$ . We can find a particular solution  $u_p$  of this equation by the procedure that we used in Examples 5.5.1–5.5.4. Then  $y_p = u_p e^{\lambda x}$  is a particular solution of (5.5.15).

**Example 5.5.5** Find a particular solution of

$$y'' - 3y' + 2y = e^{-2x} [2 \cos 3x - (34 - 150x) \sin 3x]. \quad (5.5.16)$$

**Solution** Let  $y = ue^{-2x}$ . Then

$$\begin{aligned} y'' - 3y' + 2y &= e^{-2x} [(u'' - 4u' + 4u) - 3(u' - 2u) + 2u] \\ &= e^{-2x} (u'' - 7u' + 12u) \\ &= e^{-2x} [2 \cos 3x - (34 - 150x) \sin 3x] \end{aligned}$$

if

$$u'' - 7u' + 12u = 2 \cos 3x - (34 - 150x) \sin 3x. \quad (5.5.17)$$

Since  $\cos 3x$  and  $\sin 3x$  aren't solutions of the complementary equation

$$u'' - 7u' + 12u = 0,$$

Theorem 5.5.1 tells us to look for a particular solution of (5.5.17) of the form

$$u_p = (A_0 + A_1x) \cos 3x + (B_0 + B_1x) \sin 3x. \quad (5.5.18)$$

Then

$$u_p' = (A_1 + 3B_0 + 3B_1x) \cos 3x + (B_1 - 3A_0 - 3A_1x) \sin 3x$$

and 
$$u_p'' = (-9A_0 + 6B_1 - 9A_1x) \cos 3x - (9B_0 + 6A_1 + 9B_1x) \sin 3x,$$



so

$$u_p'' - 7u_p' + 12u_p = [3A_0 - 21B_0 - 7A_1 + 6B_1 + (3A_1 - 21B_1)x] \cos 3x \\ + [21A_0 + 3B_0 - 6A_1 - 7B_1 + (21A_1 + 3B_1)x] \sin 3x.$$

Comparing the coefficients of  $x \cos 3x$ ,  $x \sin 3x$ ,  $\cos 3x$ , and  $\sin 3x$  here with the corresponding coefficients on the right side of (5.5.17) shows that  $u_p$  is a solution of (5.5.17) if

$$\begin{aligned} 3A_1 - 21B_1 &= 0 \\ 21A_1 + 3B_1 &= 150 \\ 3A_0 - 21B_0 - 7A_1 + 6B_1 &= 2 \\ 21A_0 + 3B_0 - 6A_1 - 7B_1 &= -34. \end{aligned} \tag{5.5.19}$$

Solving the first two equations yields  $A_1 = 7$ ,  $B_1 = 1$ . Substituting these values into the last two equations of (5.5.19) yields

$$\begin{aligned} 3A_0 - 21B_0 &= 2 + 7A_1 - 6B_1 = 45 \\ 21A_0 + 3B_0 &= -34 + 6A_1 + 7B_1 = 15. \end{aligned}$$

Solving this system yields  $A_0 = 1$ ,  $B_0 = -2$ . Substituting  $A_0 = 1$ ,  $A_1 = 7$ ,  $B_0 = -2$ , and  $B_1 = 1$  into (5.5.18) shows that

$$u_p = (1 + 7x) \cos 3x - (2 - x) \sin 3x$$

is a particular solution of (5.5.17). Therefore

$$y_p = e^{-2x} [(1 + 7x) \cos 3x - (2 - x) \sin 3x]$$

is a particular solution of (5.5.16).

**Example 5.5.6** Find a particular solution of

$$y'' + 2y' + 5y = e^{-x} [(6 - 16x) \cos 2x - (8 + 8x) \sin 2x]. \tag{5.5.20}$$

**Solution** Let  $y = ue^{-x}$ . Then

$$\begin{aligned} y'' + 2y' + 5y &= e^{-x} [(u'' - 2u' + u) + 2(u' - u) + 5u] \\ &= e^{-x} (u'' + 4u) \\ &= e^{-x} [(6 - 16x) \cos 2x - (8 + 8x) \sin 2x] \end{aligned}$$

if

$$u'' + 4u = (6 - 16x) \cos 2x - (8 + 8x) \sin 2x. \tag{5.5.21}$$

Since  $\cos 2x$  and  $\sin 2x$  are solutions of the complementary equation

$$u'' + 4u = 0,$$

Theorem 5.5.1 tells us to look for a particular solution of (5.5.21) of the form

$$u_p = (A_0x + A_1x^2) \cos 2x + (B_0x + B_1x^2) \sin 2x.$$

Then

$$u'_p = [A_0 + (2A_1 + 2B_0)x + 2B_1x^2] \cos 2x \\ + [B_0 + (2B_1 - 2A_0)x - 2A_1x^2] \sin 2x$$

and

$$u''_p = [2A_1 + 4B_0 - (4A_0 - 8B_1)x - 4A_1x^2] \cos 2x \\ + [2B_1 - 4A_0 - (4B_0 + 8A_1)x - 4B_1x^2] \sin 2x,$$

so

$$u''_p + 4u_p = (2A_1 + 4B_0 + 8B_1x) \cos 2x + (2B_1 - 4A_0 - 8A_1x) \sin 2x.$$

Equating the coefficients of  $x \cos 2x$ ,  $x \sin 2x$ ,  $\cos 2x$ , and  $\sin 2x$  here with the corresponding coefficients on the right side of (5.5.21) shows that  $u_p$  is a solution of (5.5.21) if

$$\begin{aligned} 8B_1 &= -16 \\ -8A_1 &= -8 \\ 4B_0 + 2A_1 &= 6 \\ -4A_0 + 2B_1 &= -8. \end{aligned} \tag{5.5.22}$$

The solution of this system is  $A_1 = 1$ ,  $B_1 = -2$ ,  $B_0 = 1$ ,  $A_0 = 1$ . Therefore

$$u_p = x[(1 + x) \cos 2x + (1 - 2x) \sin 2x]$$

is a particular solution of (5.5.21), and

$$y_p = xe^{-x} [(1 + x) \cos 2x + (1 - 2x) \sin 2x]$$

is a particular solution of (5.5.20). ■

You can also find a particular solution of (5.5.20) by substituting

$$y_p = xe^{-x} [(A_0 + A_1x) \cos 2x + (B_0 + B_1x) \sin 2x]$$

for  $y$  in (5.5.20) and equating the coefficients of  $xe^{-x} \cos 2x$ ,  $xe^{-x} \sin 2x$ ,  $e^{-x} \cos 2x$ , and  $e^{-x} \sin 2x$  in the resulting expression for

$$y''_p + 2y'_p + 5y_p$$

with the corresponding coefficients on the right side of (5.5.20). (See Exercise 38). This leads to the same system (5.5.22) of equations for  $A_0$ ,  $A_1$ ,  $B_0$ , and  $B_1$  that we obtained in Example 5.5.6. However, if you try this approach you'll see that deriving (5.5.22) this way is much more tedious than the way we did it in Example 5.5.6.

## 5.5 Exercises

In Exercises 1–17 find a particular solution.

1.  $y'' + 3y' + 2y = 7 \cos x - \sin x$
2.  $y'' + 3y' + y = (2 - 6x) \cos x - 9 \sin x$
3.  $y'' + 2y' + y = e^x(6 \cos x + 17 \sin x)$
4.  $y'' + 3y' - 2y = -e^{2x}(5 \cos 2x + 9 \sin 2x)$
5.  $y'' - y' + y = e^x(2 + x) \sin x$
6.  $y'' + 3y' - 2y = e^{-2x} [(4 + 20x) \cos 3x + (26 - 32x) \sin 3x]$

7.  $y'' + 4y = -12 \cos 2x - 4 \sin 2x$
8.  $y'' + y = (-4 + 8x) \cos x + (8 - 4x) \sin x$
9.  $4y'' + y = -4 \cos x/2 - 8x \sin x/2$
10.  $y'' + 2y' + 2y = e^{-x}(8 \cos x - 6 \sin x)$
11.  $y'' - 2y' + 5y = e^x [(6 + 8x) \cos 2x + (6 - 8x) \sin 2x]$
12.  $y'' + 2y' + y = 8x^2 \cos x - 4x \sin x$
13.  $y'' + 3y' + 2y = (12 + 20x + 10x^2) \cos x + 8x \sin x$
14.  $y'' + 3y' + 2y = (1 - x - 4x^2) \cos 2x - (1 + 7x + 2x^2) \sin 2x$
15.  $y'' - 5y' + 6y = -e^x [(4 + 6x - x^2) \cos x - (2 - 4x + 3x^2) \sin x]$
16.  $y'' - 2y' + y = -e^x [(3 + 4x - x^2) \cos x + (3 - 4x - x^2) \sin x]$
17.  $y'' - 2y' + 2y = e^x [(2 - 2x - 6x^2) \cos x + (2 - 10x + 6x^2) \sin x]$

In Exercises 1–17 find a particular solution and graph it.

18. C/G  $y'' + 2y' + y = e^{-x} [(5 - 2x) \cos x - (3 + 3x) \sin x]$
19. C/G  $y'' + 9y = -6 \cos 3x - 12 \sin 3x$
20. C/G  $y'' + 3y' + 2y = (1 - x - 4x^2) \cos 2x - (1 + 7x + 2x^2) \sin 2x$
21. C/G  $y'' + 4y' + 3y = e^{-x} [(2 + x + x^2) \cos x + (5 + 4x + 2x^2) \sin x]$

In Exercises 22–26 solve the initial value problem.

22.  $y'' - 7y' + 6y = -e^x(17 \cos x - 7 \sin x)$ ,  $y(0) = 4$ ,  $y'(0) = 2$
23.  $y'' - 2y' + 2y = -e^x(6 \cos x + 4 \sin x)$ ,  $y(0) = 1$ ,  $y'(0) = 4$
24.  $y'' + 6y' + 10y = -40e^x \sin x$ ,  $y(0) = 2$ ,  $y'(0) = -3$
25.  $y'' - 6y' + 10y = -e^{3x}(6 \cos x + 4 \sin x)$ ,  $y(0) = 2$ ,  $y'(0) = 7$
26.  $y'' - 3y' + 2y = e^{3x} [21 \cos x - (11 + 10x) \sin x]$ ,  $y(0) = 0$ ,  $y'(0) = 6$

In Exercises 27–32 use the principle of superposition to find a particular solution. Where indicated, solve the initial value problem.

27.  $y'' - 2y' - 3y = 4e^{3x} + e^x(\cos x - 2 \sin x)$
28.  $y'' + y = 4 \cos x - 2 \sin x + xe^x + e^{-x}$
29.  $y'' - 3y' + 2y = xe^x + 2e^{2x} + \sin x$
30.  $y'' - 2y' + 2y = 4xe^x \cos x + xe^{-x} + 1 + x^2$
31.  $y'' - 4y' + 4y = e^{2x}(1 + x) + e^{2x}(\cos x - \sin x) + 3e^{3x} + 1 + x$
32.  $y'' - 4y' + 4y = 6e^{2x} + 25 \sin x$ ,  $y(0) = 5$ ,  $y'(0) = 3$

In Exercises 33–35 solve the initial value problem and graph the solution.

33. C/G  $y'' + 4y = -e^{-2x} [(4 - 7x) \cos x + (2 - 4x) \sin x]$ ,  $y(0) = 3$ ,  $y'(0) = 1$
34. C/G  $y'' + 4y' + 4y = 2 \cos 2x + 3 \sin 2x + e^{-x}$ ,  $y(0) = -1$ ,  $y'(0) = 2$

35. C/G  $y'' + 4y = e^x(11 + 15x) + 8 \cos 2x - 12 \sin 2x, \quad y(0) = 3, \quad y'(0) = 5$

36. (a) Verify that if

$$y_p = A(x) \cos \omega x + B(x) \sin \omega x$$

where  $A$  and  $B$  are twice differentiable, then

$$\begin{aligned} y'_p &= (A' + \omega B) \cos \omega x + (B' - \omega A) \sin \omega x \text{ and} \\ y''_p &= (A'' + 2\omega B' - \omega^2 A) \cos \omega x + (B'' - 2\omega A' - \omega^2 B) \sin \omega x. \end{aligned}$$

(b) Use the results of (a) to verify that

$$\begin{aligned} ay''_p + by'_p + cy_p &= [(c - a\omega^2)A + b\omega B + 2a\omega B' + bA' + aA''] \cos \omega x + \\ &\quad [-b\omega A + (c - a\omega^2)B - 2a\omega A' + bB' + aB''] \sin \omega x. \end{aligned}$$

(c) Use the results of (a) to verify that

$$y''_p + \omega^2 y_p = (A'' + 2\omega B') \cos \omega x + (B'' - 2\omega A') \sin \omega x.$$

(d) Prove Theorem 5.5.2.

37. Let  $a, b, c$ , and  $\omega$  be constants, with  $a \neq 0$  and  $\omega > 0$ , and let

$$P(x) = p_0 + p_1x + \cdots + p_kx^k \quad \text{and} \quad Q(x) = q_0 + q_1x + \cdots + q_kx^k,$$

where at least one of the coefficients  $p_k, q_k$  is nonzero, so  $k$  is the larger of the degrees of  $P$  and  $Q$ .

(a) Show that if  $\cos \omega x$  and  $\sin \omega x$  are not solutions of the complementary equation

$$ay'' + by' + cy = 0,$$

then there are polynomials

$$A(x) = A_0 + A_1x + \cdots + A_kx^k \quad \text{and} \quad B(x) = B_0 + B_1x + \cdots + B_kx^k \quad (\text{A})$$

such that

$$\begin{aligned} (c - a\omega^2)A + b\omega B + 2a\omega B' + bA' + aA'' &= P \\ -b\omega A + (c - a\omega^2)B - 2a\omega A' + bB' + aB'' &= Q, \end{aligned}$$

where  $(A_k, B_k), (A_{k-1}, B_{k-1}), \dots, (A_0, B_0)$  can be computed successively by solving the systems

$$\begin{aligned} (c - a\omega^2)A_k + b\omega B_k &= p_k \\ -b\omega A_k + (c - a\omega^2)B_k &= q_k, \end{aligned}$$

and, if  $1 \leq r \leq k$ ,

$$\begin{aligned} (c - a\omega^2)A_{k-r} + b\omega B_{k-r} &= p_{k-r} + \cdots \\ -b\omega A_{k-r} + (c - a\omega^2)B_{k-r} &= q_{k-r} + \cdots, \end{aligned}$$

where the terms indicated by “ $\cdots$ ” depend upon the previously computed coefficients with subscripts greater than  $k - r$ . Conclude from this and Exercise 36(b) that

$$y_p = A(x) \cos \omega x + B(x) \sin \omega x \quad (\text{B})$$

is a particular solution of

$$ay'' + by' + cy = P(x) \cos \omega x + Q(x) \sin \omega x.$$

(b) Conclude from Exercise 36(c) that the equation

$$a(y'' + \omega^2 y) = P(x) \cos \omega x + Q(x) \sin \omega x \quad (\text{C})$$

does not have a solution of the form (B) with  $A$  and  $B$  as in (A). Then show that there are polynomials

$$A(x) = A_0 x + A_1 x^2 + \cdots + A_k x^{k+1} \quad \text{and} \quad B(x) = B_0 x + B_1 x^2 + \cdots + B_k x^{k+1}$$

such that

$$\begin{aligned} a(A'' + 2\omega B') &= P \\ a(B'' - 2\omega A') &= Q, \end{aligned}$$

where the pairs  $(A_k, B_k)$ ,  $(A_{k-1}, B_{k-1})$ ,  $\dots$ ,  $(A_0, B_0)$  can be computed successively as follows:

$$\begin{aligned} A_k &= -\frac{q_k}{2a\omega(k+1)} \\ B_k &= \frac{p_k}{2a\omega(k+1)}, \end{aligned}$$

and, if  $k \geq 1$ ,

$$\begin{aligned} A_{k-j} &= -\frac{1}{2\omega} \left[ \frac{q_{k-j}}{a(k-j+1)} - (k-j+2)B_{k-j+1} \right] \\ B_{k-j} &= \frac{1}{2\omega} \left[ \frac{p_{k-j}}{a(k-j+1)} - (k-j+2)A_{k-j+1} \right] \end{aligned}$$

for  $1 \leq j \leq k$ . Conclude that (B) with this choice of the polynomials  $A$  and  $B$  is a particular solution of (C).

38. Show that Theorem 5.5.1 implies the next theorem: *Suppose  $\omega$  is a positive number and  $P$  and  $Q$  are polynomials. Let  $k$  be the larger of the degrees of  $P$  and  $Q$ . Then the equation*

$$ay'' + by' + cy = e^{\lambda x} (P(x) \cos \omega x + Q(x) \sin \omega x)$$

*has a particular solution*

$$y_p = e^{\lambda x} (A(x) \cos \omega x + B(x) \sin \omega x), \quad (\text{A})$$

*where*

$$A(x) = A_0 + A_1 x + \cdots + A_k x^k \quad \text{and} \quad B(x) = B_0 + B_1 x + \cdots + B_k x^k,$$

*provided that  $e^{\lambda x} \cos \omega x$  and  $e^{\lambda x} \sin \omega x$  are not solutions of the complementary equation. The equation*

$$a[y'' - 2\lambda y' + (\lambda^2 + \omega^2)y] = e^{\lambda x} (P(x) \cos \omega x + Q(x) \sin \omega x)$$

*(for which  $e^{\lambda x} \cos \omega x$  and  $e^{\lambda x} \sin \omega x$  are solutions of the complementary equation) has a particular solution of the form (A), where*

$$A(x) = A_0 x + A_1 x^2 + \cdots + A_k x^{k+1} \quad \text{and} \quad B(x) = B_0 x + B_1 x^2 + \cdots + B_k x^{k+1}.$$

39. This exercise presents a method for evaluating the integral

$$y = \int e^{\lambda x} (P(x) \cos \omega x + Q(x) \sin \omega x) dx$$

where  $\omega \neq 0$  and

$$P(x) = p_0 + p_1x + \cdots + p_kx^k, \quad Q(x) = q_0 + q_1x + \cdots + q_kx^k.$$

(a) Show that  $y = e^{\lambda x}u$ , where

$$u' + \lambda u = P(x) \cos \omega x + Q(x) \sin \omega x. \quad (\text{A})$$

(b) Show that (A) has a particular solution of the form

$$u_p = A(x) \cos \omega x + B(x) \sin \omega x,$$

where

$$A(x) = A_0 + A_1x + \cdots + A_kx^k, \quad B(x) = B_0 + B_1x + \cdots + B_kx^k,$$

and the pairs of coefficients  $(A_k, B_k), (A_{k-1}, B_{k-1}), \dots, (A_0, B_0)$  can be computed successively as the solutions of pairs of equations obtained by equating the coefficients of  $x^r \cos \omega x$  and  $x^r \sin \omega x$  for  $r = k, k-1, \dots, 0$ .

(c) Conclude that

$$\int e^{\lambda x} (P(x) \cos \omega x + Q(x) \sin \omega x) dx = e^{\lambda x} (A(x) \cos \omega x + B(x) \sin \omega x) + c,$$

where  $c$  is a constant of integration.

40. Use the method of Exercise 39 to evaluate the integral.

(a)  $\int x^2 \cos x dx$

(b)  $\int x^2 e^x \cos x dx$

(c)  $\int x e^{-x} \sin 2x dx$

(d)  $\int x^2 e^{-x} \sin x dx$

(e)  $\int x^3 e^x \sin x dx$

(f)  $\int e^x [x \cos x - (1 + 3x) \sin x] dx$

(g)  $\int e^{-x} [(1 + x^2) \cos x + (1 - x^2) \sin x] dx$

## 5.6 REDUCTION OF ORDER

In this section we give a method for finding the general solution of

$$P_0(x)y'' + P_1(x)y' + P_2(x)y = F(x) \quad (5.6.1)$$

if we know a nontrivial solution  $y_1$  of the complementary equation

$$P_0(x)y'' + P_1(x)y' + P_2(x)y = 0. \quad (5.6.2)$$

The method is called *reduction of order* because it reduces the task of solving (5.6.1) to solving a first order equation. Unlike the method of undetermined coefficients, it does not require  $P_0, P_1,$  and  $P_2$  to be constants, or  $F$  to be of any special form.

By now you shouldn't be surprised that we look for solutions of (5.6.1) in the form

$$y = uy_1 \quad (5.6.3)$$

where  $u$  is to be determined so that  $y$  satisfies (5.6.1). Substituting (5.6.3) and

$$\begin{aligned} y' &= u'y_1 + uy_1' \\ y'' &= u''y_1 + 2u'y_1' + uy_1'' \end{aligned}$$

into (5.6.1) yields

$$P_0(x)(u''y_1 + 2u'y_1' + uy_1'') + P_1(x)(u'y_1 + uy_1') + P_2(x)uy_1 = F(x).$$

Collecting the coefficients of  $u$ ,  $u'$ , and  $u''$  yields

$$(P_0y_1)u'' + (2P_0y_1' + P_1y_1)u' + (P_0y_1'' + P_1y_1' + P_2y_1)u = F. \quad (5.6.4)$$

However, the coefficient of  $u$  is zero, since  $y_1$  satisfies (5.6.2). Therefore (5.6.4) reduces to

$$Q_0(x)u'' + Q_1(x)u' = F, \quad (5.6.5)$$

with

$$Q_0 = P_0y_1 \quad \text{and} \quad Q_1 = 2P_0y_1' + P_1y_1.$$

(It isn't worthwhile to memorize the formulas for  $Q_0$  and  $Q_1$ !) Since (5.6.5) is a linear first order equation in  $u'$ , we can solve it for  $u'$  by variation of parameters as in Section 1.2, integrate the solution to obtain  $u$ , and then obtain  $y$  from (5.6.3).

### Example 5.6.1

(a) Find the general solution of

$$xy'' - (2x + 1)y' + (x + 1)y = x^2, \quad (5.6.6)$$

given that  $y_1 = e^x$  is a solution of the complementary equation

$$xy'' - (2x + 1)y' + (x + 1)y = 0. \quad (5.6.7)$$

(b) As a byproduct of (a), find a fundamental set of solutions of (5.6.7).

**SOLUTION(a)** If  $y = ue^x$ , then  $y' = u'e^x + ue^x$  and  $y'' = u''e^x + 2u'e^x + ue^x$ , so

$$\begin{aligned} xy'' - (2x + 1)y' + (x + 1)y &= x(u''e^x + 2u'e^x + ue^x) \\ &\quad - (2x + 1)(u'e^x + ue^x) + (x + 1)ue^x \\ &= (xu'' - u')e^x. \end{aligned}$$

Therefore  $y = ue^x$  is a solution of (5.6.6) if and only if

$$(xu'' - u')e^x = x^2,$$

which is a first order equation in  $u'$ . We rewrite it as

$$u'' - \frac{u'}{x} = xe^{-x}. \quad (5.6.8)$$

To focus on how we apply variation of parameters to this equation, we temporarily write  $z = u'$ , so that (5.6.8) becomes

$$z' - \frac{z}{x} = xe^{-x}. \quad (5.6.9)$$

We leave it to you to show (by separation of variables) that  $z_1 = x$  is a solution of the complementary equation

$$z' - \frac{z}{x} = 0$$

for (5.6.9). By applying variation of parameters as in Section 1.2, we can now see that every solution of (5.6.9) is of the form

$$z = vx \quad \text{where} \quad v'x = xe^{-x}, \quad \text{so} \quad v' = e^{-x} \quad \text{and} \quad v = -e^{-x} + C_1.$$

Since  $u' = z = vx$ ,  $u$  is a solution of (5.6.8) if and only if

$$u' = vx = -xe^{-x} + C_1x.$$

Integrating this yields

$$u = (x+1)e^{-x} + \frac{C_1}{2}x^2 + C_2.$$

Therefore the general solution of (5.6.6) is

$$y = ue^x = x + 1 + \frac{C_1}{2}x^2e^x + C_2e^x. \quad (5.6.10)$$

**SOLUTION(b)** By letting  $C_1 = C_2 = 0$  in (5.6.10), we see that  $y_{p_1} = x + 1$  is a solution of (5.6.6). By letting  $C_1 = 2$  and  $C_2 = 0$ , we see that  $y_{p_2} = x + 1 + x^2e^x$  is also a solution of (5.6.6). Since the difference of two solutions of (5.6.6) is a solution of (5.6.7),  $y_2 = y_{p_1} - y_{p_2} = x^2e^x$  is a solution of (5.6.7). Since  $y_2/y_1$  is nonconstant and we already know that  $y_1 = e^x$  is a solution of (5.6.6), Theorem 5.1.6 implies that  $\{e^x, x^2e^x\}$  is a fundamental set of solutions of (5.6.7). ■

Although (5.6.10) is a correct form for the general solution of (5.6.6), it's silly to leave the arbitrary coefficient of  $x^2e^x$  as  $C_1/2$  where  $C_1$  is an arbitrary constant. Moreover, it's sensible to make the subscripts of the coefficients of  $y_1 = e^x$  and  $y_2 = x^2e^x$  consistent with the subscripts of the functions themselves. Therefore we rewrite (5.6.10) as

$$y = x + 1 + c_1e^x + c_2x^2e^x$$

by simply renaming the arbitrary constants. We'll also do this in the next two examples, and in the answers to the exercises.

### Example 5.6.2

(a) Find the general solution of

$$x^2y'' + xy' - y = x^2 + 1,$$

given that  $y_1 = x$  is a solution of the complementary equation

$$x^2y'' + xy' - y = 0. \quad (5.6.11)$$

As a byproduct of this result, find a fundamental set of solutions of (5.6.11).

(b) Solve the initial value problem

$$x^2y'' + xy' - y = x^2 + 1, \quad y(1) = 2, \quad y'(1) = -3. \quad (5.6.12)$$



**SOLUTION(a)** If  $y = ux$ , then  $y' = u'x + u$  and  $y'' = u''x + 2u'$ , so

$$\begin{aligned}x^2y'' + xy' - y &= x^2(u''x + 2u') + x(u'x + u) - ux \\ &= x^3u'' + 3x^2u'.\end{aligned}$$

Therefore  $y = ux$  is a solution of (5.6.12) if and only if

$$x^3u'' + 3x^2u' = x^2 + 1,$$

which is a first order equation in  $u'$ . We rewrite it as

$$u'' + \frac{3}{x}u' = \frac{1}{x} + \frac{1}{x^3}. \quad (5.6.13)$$

To focus on how we apply variation of parameters to this equation, we temporarily write  $z = u'$ , so that (5.6.13) becomes

$$z' + \frac{3}{x}z = \frac{1}{x} + \frac{1}{x^3}. \quad (5.6.14)$$

We leave it to you to show by separation of variables that  $z_1 = 1/x^3$  is a solution of the complementary equation

$$z' + \frac{3}{x}z = 0$$

for (5.6.14). By variation of parameters, every solution of (5.6.14) is of the form

$$z = \frac{v}{x^3} \quad \text{where} \quad \frac{v'}{x^3} = \frac{1}{x} + \frac{1}{x^3}, \quad \text{so} \quad v' = x^2 + 1 \quad \text{and} \quad v = \frac{x^3}{3} + x + C_1.$$

Since  $u' = z = v/x^3$ ,  $u$  is a solution of (5.6.14) if and only if

$$u' = \frac{v}{x^3} = \frac{1}{3} + \frac{1}{x^2} + \frac{C_1}{x^3}.$$

Integrating this yields

$$u = \frac{x}{3} - \frac{1}{x} - \frac{C_1}{2x^2} + C_2.$$

Therefore the general solution of (5.6.12) is

$$y = ux = \frac{x^2}{3} - 1 - \frac{C_1}{2x} + C_2x. \quad (5.6.15)$$

Reasoning as in the solution of Example 5.6.1(a), we conclude that  $y_1 = x$  and  $y_2 = 1/x$  form a fundamental set of solutions for (5.6.11).

As we explained above, we rename the constants in (5.6.15) and rewrite it as

$$y = \frac{x^2}{3} - 1 + c_1x + \frac{c_2}{x}. \quad (5.6.16)$$

**SOLUTION(b)** Differentiating (5.6.16) yields

$$y' = \frac{2x}{3} + c_1 - \frac{c_2}{x^2}. \quad (5.6.17)$$

Setting  $x = 1$  in (5.6.16) and (5.6.17) and imposing the initial conditions  $y(1) = 2$  and  $y'(1) = -3$  yields

$$\begin{aligned}c_1 + c_2 &= \frac{8}{3} \\c_1 - c_2 &= -\frac{11}{3}.\end{aligned}$$

Solving these equations yields  $c_1 = -1/2$ ,  $c_2 = 19/6$ . Therefore the solution of (5.6.12) is

$$y = \frac{x^2}{3} - 1 - \frac{x}{2} + \frac{19}{6x}.$$

Using reduction of order to find the general solution of a homogeneous linear second order equation leads to a homogeneous linear first order equation in  $u'$  that can be solved by separation of variables. The next example illustrates this.

**Example 5.6.3** Find the general solution and a fundamental set of solutions of

$$x^2y'' - 3xy' + 3y = 0, \quad (5.6.18)$$

given that  $y_1 = x$  is a solution.

**Solution** If  $y = ux$  then  $y' = u'x + u$  and  $y'' = u''x + 2u'$ , so

$$\begin{aligned}x^2y'' - 3xy' + 3y &= x^2(u''x + 2u') - 3x(u'x + u) + 3ux \\ &= x^3u'' - x^2u'.\end{aligned}$$

Therefore  $y = ux$  is a solution of (5.6.18) if and only if

$$x^3u'' - x^2u' = 0.$$

Separating the variables  $u'$  and  $x$  yields

$$\frac{u''}{u'} = \frac{1}{x},$$

so

$$\ln|u'| = \ln|x| + k, \quad \text{or, equivalently,} \quad u' = C_1x.$$

Therefore

$$u = \frac{C_1}{2}x^2 + C_2,$$

so the general solution of (5.6.18) is

$$y = ux = \frac{C_1}{2}x^3 + C_2x,$$

which we rewrite as

$$y = c_1x + c_2x^3.$$

Therefore  $\{x, x^3\}$  is a fundamental set of solutions of (5.6.18).

## 5.6 Exercises

In Exercises 1–17 find the general solution, given that  $y_1$  satisfies the complementary equation. As a byproduct, find a fundamental set of solutions of the complementary equation.

1.  $(2x + 1)y'' - 2y' - (2x + 3)y = (2x + 1)^2$ ;  $y_1 = e^{-x}$
2.  $x^2y'' + xy' - y = \frac{4}{x^2}$ ;  $y_1 = x$
3.  $x^2y'' - xy' + y = x$ ;  $y_1 = x$
4.  $y'' - 3y' + 2y = \frac{1}{1 + e^{-x}}$ ;  $y_1 = e^{2x}$
5.  $y'' - 2y' + y = 7x^{3/2}e^x$ ;  $y_1 = e^x$
6.  $4x^2y'' + (4x - 8x^2)y' + (4x^2 - 4x - 1)y = 4x^{1/2}e^x(1 + 4x)$ ;  $y_1 = x^{1/2}e^x$
7.  $y'' - 2y' + 2y = e^x \sec x$ ;  $y_1 = e^x \cos x$
8.  $y'' + 4xy' + (4x^2 + 2)y = 8e^{-x(x+2)}$ ;  $y_1 = e^{-x^2}$
9.  $x^2y'' + xy' - 4y = -6x - 4$ ;  $y_1 = x^2$
10.  $x^2y'' + 2x(x - 1)y' + (x^2 - 2x + 2)y = x^3e^{2x}$ ;  $y_1 = xe^{-x}$
11.  $x^2y'' - x(2x - 1)y' + (x^2 - x - 1)y = x^2e^x$ ;  $y_1 = xe^x$
12.  $(1 - 2x)y'' + 2y' + (2x - 3)y = (1 - 4x + 4x^2)e^x$ ;  $y_1 = e^x$
13.  $x^2y'' - 3xy' + 4y = 4x^4$ ;  $y_1 = x^2$
14.  $2xy'' + (4x + 1)y' + (2x + 1)y = 3x^{1/2}e^{-x}$ ;  $y_1 = e^{-x}$
15.  $xy'' - (2x + 1)y' + (x + 1)y = -e^x$ ;  $y_1 = e^x$
16.  $4x^2y'' - 4x(x + 1)y' + (2x + 3)y = 4x^{5/2}e^{2x}$ ;  $y_1 = x^{1/2}$
17.  $x^2y'' - 5xy' + 8y = 4x^2$ ;  $y_1 = x^2$

In Exercises 18–30 find a fundamental set of solutions, given that  $y_1$  is a solution.

18.  $xy'' + (2 - 2x)y' + (x - 2)y = 0$ ;  $y_1 = e^x$
19.  $x^2y'' - 4xy' + 6y = 0$ ;  $y_1 = x^2$
20.  $x^2(\ln|x|)^2y'' - (2x \ln|x|)y' + (2 + \ln|x|)y = 0$ ;  $y_1 = \ln|x|$
21.  $4xy'' + 2y' + y = 0$ ;  $y_1 = \sin \sqrt{x}$
22.  $xy'' - (2x + 2)y' + (x + 2)y = 0$ ;  $y_1 = e^x$
23.  $x^2y'' - (2a - 1)xy' + a^2y = 0$ ;  $y_1 = x^a$
24.  $x^2y'' - 2xy' + (x^2 + 2)y = 0$ ;  $y_1 = x \sin x$
25.  $xy'' - (4x + 1)y' + (4x + 2)y = 0$ ;  $y_1 = e^{2x}$
26.  $4x^2(\sin x)y'' - 4x(x \cos x + \sin x)y' + (2x \cos x + 3 \sin x)y = 0$ ;  $y_1 = x^{1/2}$
27.  $4x^2y'' - 4xy' + (3 - 16x^2)y = 0$ ;  $y_1 = x^{1/2}e^{2x}$
28.  $(2x + 1)xy'' - 2(2x^2 - 1)y' - 4(x + 1)y = 0$ ;  $y_1 = 1/x$
29.  $(x^2 - 2x)y'' + (2 - x^2)y' + (2x - 2)y = 0$ ;  $y_1 = e^x$
30.  $xy'' - (4x + 1)y' + (4x + 2)y = 0$ ;  $y_1 = e^{2x}$

In Exercises 31–33 solve the initial value problem, given that  $y_1$  satisfies the complementary equation.

31.  $x^2y'' - 3xy' + 4y = 4x^4$ ,  $y(-1) = 7$ ,  $y'(-1) = -8$ ;  $y_1 = x^2$
32.  $(3x - 1)y'' - (3x + 2)y' - (6x - 8)y = 0$ ,  $y(0) = 2$ ,  $y'(0) = 3$ ;  $y_1 = e^{2x}$

33.  $(x+1)^2 y'' - 2(x+1)y' - (x^2 + 2x - 1)y = (x+1)^3 e^x$ ,  $y(0) = 1$ ,  $y'(0) = -1$ ;  
 $y_1 = (x+1)e^x$

In Exercises 34 and 35 solve the initial value problem and graph the solution, given that  $y_1$  satisfies the complementary equation.

34. C/G  $x^2 y'' + 2xy' - 2y = x^2$ ,  $y(1) = \frac{5}{4}$ ,  $y'(1) = \frac{3}{2}$ ;  $y_1 = x$

35. C/G  $(x^2 - 4)y'' + 4xy' + 2y = x + 2$ ,  $y(0) = -\frac{1}{3}$ ,  $y'(0) = -1$ ;  $y_1 = \frac{1}{x-2}$

36. Suppose  $p_1$  and  $p_2$  are continuous on  $(a, b)$ . Let  $y_1$  be a solution of

$$y'' + p_1(x)y' + p_2(x)y = 0 \quad (\text{A})$$

that has no zeros on  $(a, b)$ , and let  $x_0$  be in  $(a, b)$ . Use reduction of order to show that  $y_1$  and

$$y_2(x) = y_1(x) \int_{x_0}^x \frac{1}{y_1^2(t)} \exp\left(-\int_{x_0}^t p_1(s) ds\right) dt$$

form a fundamental set of solutions of (A) on  $(a, b)$ . (NOTE: This exercise is related to Exercise 9.)

37. The nonlinear first order equation

$$y' + y^2 + p(x)y + q(x) = 0 \quad (\text{A})$$

is a *Riccati equation*. (See Exercise 2.4.55.) Assume that  $p$  and  $q$  are continuous.

- (a) Show that  $y$  is a solution of (A) if and only if  $y = z'/z$ , where

$$z'' + p(x)z' + q(x)z = 0. \quad (\text{B})$$

- (b) Show that the general solution of (A) is

$$y = \frac{c_1 z'_1 + c_2 z'_2}{c_1 z_1 + c_2 z_2}, \quad (\text{C})$$

where  $\{z_1, z_2\}$  is a fundamental set of solutions of (B) and  $c_1$  and  $c_2$  are arbitrary constants.

- (c) Does the formula (C) imply that the first order equation (A) has a two-parameter family of solutions? Explain your answer.

38. Use a method suggested by Exercise 37 to find all solutions of the equation.

(a) $y' + y^2 + k^2 = 0$	(b) $y' + y^2 - 3y + 2 = 0$
(c) $y' + y^2 + 5y - 6 = 0$	(d) $y' + y^2 + 8y + 7 = 0$
(e) $y' + y^2 + 14y + 50 = 0$	(f) $6y' + 6y^2 - y - 1 = 0$
(g) $36y' + 36y^2 - 12y + 1 = 0$	

39. Use a method suggested by Exercise 37 and reduction of order to find all solutions of the equation, given that  $y_1$  is a solution.

(a) $x^2(y' + y^2) - x(x+2)y + x + 2 = 0$ ; $y_1 = 1/x$
(b) $y' + y^2 + 4xy + 4x^2 + 2 = 0$ ; $y_1 = -2x$
(c) $(2x+1)(y' + y^2) - 2y - (2x+3) = 0$ ; $y_1 = -1$
(d) $(3x-1)(y' + y^2) - (3x+2)y - 6x + 8 = 0$ ; $y_1 = 2$

$$(e) \quad x^2(y' + y^2) + xy + x^2 - \frac{1}{4} = 0; \quad y_1 = -\tan x - \frac{1}{2x}$$

$$(f) \quad x^2(y' + y^2) - 7xy + 7 = 0; \quad y_1 = 1/x$$

40. The nonlinear first order equation

$$y' + r(x)y^2 + p(x)y + q(x) = 0 \tag{A}$$

is the *generalized Riccati equation*. (See Exercise 2.4.55.) Assume that  $p$  and  $q$  are continuous and  $r$  is differentiable.

(a) Show that  $y$  is a solution of (A) if and only if  $y = z'/rz$ , where

$$z'' + \left[ p(x) - \frac{r'(x)}{r(x)} \right] z' + r(x)q(x)z = 0. \tag{B}$$

(b) Show that the general solution of (A) is

$$y = \frac{c_1 z_1' + c_2 z_2'}{r(c_1 z_1 + c_2 z_2)},$$

where  $\{z_1, z_2\}$  is a fundamental set of solutions of (B) and  $c_1$  and  $c_2$  are arbitrary constants.

## 5.7 VARIATION OF PARAMETERS

In this section we give a method called *variation of parameters* for finding a particular solution of

$$P_0(x)y'' + P_1(x)y' + P_2(x)y = F(x) \tag{5.7.1}$$

if we know a fundamental set  $\{y_1, y_2\}$  of solutions of the complementary equation

$$P_0(x)y'' + P_1(x)y' + P_2(x)y = 0. \tag{5.7.2}$$

Having found a particular solution  $y_p$  by this method, we can write the general solution of (5.7.1) as

$$y = y_p + c_1 y_1 + c_2 y_2.$$

Since we need only one nontrivial solution of (5.7.2) to find the general solution of (5.7.1) by reduction of order, it's natural to ask why we're interested in variation of parameters, which requires two linearly independent solutions of (5.7.2) to achieve the same goal. Here's the answer:

- If we already know two linearly independent solutions of (5.7.2) then variation of parameters will probably be simpler than reduction of order.
- Variation of parameters generalizes naturally to a method for finding particular solutions of higher order linear equations (Section 9.4) and linear systems of equations (Section 10.7), while reduction of order doesn't.
- Variation of parameters is a powerful theoretical tool used by researchers in differential equations. Although a detailed discussion of this is beyond the scope of this book, you can get an idea of what it means from Exercises 37–39.

We'll now derive the method. As usual, we consider solutions of (5.7.1) and (5.7.2) on an interval  $(a, b)$  where  $P_0$ ,  $P_1$ ,  $P_2$ , and  $F$  are continuous and  $P_0$  has no zeros. Suppose that  $\{y_1, y_2\}$  is a fundamental set of solutions of the complementary equation (5.7.2). We look for a particular solution of (5.7.1) in the form

$$y_p = u_1 y_1 + u_2 y_2 \quad (5.7.3)$$

where  $u_1$  and  $u_2$  are functions to be determined so that  $y_p$  satisfies (5.7.1). You may not think this is a good idea, since there are now two unknown functions to be determined, rather than one. However, since  $u_1$  and  $u_2$  have to satisfy only one condition (that  $y_p$  is a solution of (5.7.1)), we can impose a second condition that produces a convenient simplification, as follows.

Differentiating (5.7.3) yields

$$y_p' = u_1 y_1' + u_2 y_2' + u_1' y_1 + u_2' y_2. \quad (5.7.4)$$

As our second condition on  $u_1$  and  $u_2$  we require that

$$u_1' y_1 + u_2' y_2 = 0. \quad (5.7.5)$$

Then (5.7.4) becomes

$$y_p' = u_1 y_1' + u_2 y_2'; \quad (5.7.6)$$

that is, (5.7.5) permits us to differentiate  $y_p$  (once!) as if  $u_1$  and  $u_2$  are constants. Differentiating (5.7.4) yields

$$y_p'' = u_1 y_1'' + u_2 y_2'' + u_1' y_1' + u_2' y_2'. \quad (5.7.7)$$

(There are no terms involving  $u_1''$  and  $u_2''$  here, as there would be if we hadn't required (5.7.5).) Substituting (5.7.3), (5.7.6), and (5.7.7) into (5.7.1) and collecting the coefficients of  $u_1$  and  $u_2$  yields

$$u_1(P_0 y_1'' + P_1 y_1' + P_2 y_1) + u_2(P_0 y_2'' + P_1 y_2' + P_2 y_2) + P_0(u_1' y_1 + u_2' y_2) = F.$$

As in the derivation of the method of reduction of order, the coefficients of  $u_1$  and  $u_2$  here are both zero because  $y_1$  and  $y_2$  satisfy the complementary equation. Hence, we can rewrite the last equation as

$$P_0(u_1' y_1 + u_2' y_2) = F. \quad (5.7.8)$$

Therefore  $y_p$  in (5.7.3) satisfies (5.7.1) if

$$\begin{aligned} u_1' y_1 + u_2' y_2 &= 0 \\ u_1' y_1 + u_2' y_2 &= \frac{F}{P_0}, \end{aligned} \quad (5.7.9)$$

where the first equation is the same as (5.7.5) and the second is from (5.7.8).

We'll now show that you can always solve (5.7.9) for  $u_1'$  and  $u_2'$ . (The method that we use here will always work, but simpler methods usually work when you're dealing with specific equations.) To obtain  $u_1'$ , multiply the first equation in (5.7.9) by  $y_2'$  and the second equation by  $y_2$ . This yields

$$\begin{aligned} u_1' y_1 y_2' + u_2' y_2 y_2' &= 0 \\ u_1' y_1' y_2 + u_2' y_2' y_2 &= \frac{F y_2}{P_0}. \end{aligned}$$

Subtracting the second equation from the first yields

$$u_1'(y_1 y_2' - y_1' y_2) = -\frac{F y_2}{P_0}. \quad (5.7.10)$$

Since  $\{y_1, y_2\}$  is a fundamental set of solutions of (5.7.2) on  $(a, b)$ , Theorem 5.1.6 implies that the Wronskian  $y_1 y_2' - y_1' y_2$  has no zeros on  $(a, b)$ . Therefore we can solve (5.7.10) for  $u_1'$ , to obtain

$$u_1' = -\frac{F y_2}{P_0(y_1 y_2' - y_1' y_2)}. \quad (5.7.11)$$

We leave it to you to start from (5.7.9) and show by a similar argument that

$$u_2' = \frac{F y_1}{P_0(y_1 y_2' - y_1' y_2)}. \quad (5.7.12)$$

We can now obtain  $u_1$  and  $u_2$  by integrating  $u_1'$  and  $u_2'$ . The constants of integration can be taken to be zero, since any choice of  $u_1$  and  $u_2$  in (5.7.3) will suffice.

You should not memorize (5.7.11) and (5.7.12). On the other hand, you don't want to rederive the whole procedure for every specific problem. We recommend the a compromise:

(a) Write

$$y_p = u_1 y_1 + u_2 y_2 \quad (5.7.13)$$

to remind yourself of what you're doing.

(b) Write the system

$$\begin{aligned} u_1' y_1 + u_2' y_2 &= 0 \\ u_1' y_1' + u_2' y_2' &= \frac{F}{P_0} \end{aligned} \quad (5.7.14)$$

for the specific problem you're trying to solve.

(c) Solve (5.7.14) for  $u_1'$  and  $u_2'$  by any convenient method.

(d) Obtain  $u_1$  and  $u_2$  by integrating  $u_1'$  and  $u_2'$ , taking the constants of integration to be zero.

(e) Substitute  $u_1$  and  $u_2$  into (5.7.13) to obtain  $y_p$ .

**Example 5.7.1** Find a particular solution  $y_p$  of

$$x^2 y'' - 2x y' + 2y = x^{9/2}, \quad (5.7.15)$$

given that  $y_1 = x$  and  $y_2 = x^2$  are solutions of the complementary equation

$$x^2 y'' - 2x y' + 2y = 0.$$

Then find the general solution of (5.7.15).

**Solution** We set

$$y_p = u_1 x + u_2 x^2,$$

where

$$\begin{aligned} u_1' x + u_2' x^2 &= 0 \\ u_1' + 2u_2' x &= \frac{x^{9/2}}{x^2} = x^{5/2}. \end{aligned}$$

From the first equation,  $u_1' = -u_2' x$ . Substituting this into the second equation yields  $u_2' x = x^{5/2}$ , so  $u_2' = x^{3/2}$  and therefore  $u_1' = -u_2' x = -x^{5/2}$ . Integrating and taking the constants of integration to be zero yields

$$u_1 = -\frac{2}{7} x^{7/2} \quad \text{and} \quad u_2 = \frac{2}{5} x^{5/2}.$$

Therefore

$$y_p = u_1x + u_2x^2 = -\frac{2}{7}x^{7/2}x + \frac{2}{5}x^{5/2}x^2 = \frac{4}{35}x^{9/2},$$

and the general solution of (5.7.15) is

$$y = \frac{4}{35}x^{9/2} + c_1x + c_2x^2.$$

**Example 5.7.2** Find a particular solution  $y_p$  of

$$(x-1)y'' - xy' + y = (x-1)^2, \quad (5.7.16)$$

given that  $y_1 = x$  and  $y_2 = e^x$  are solutions of the complementary equation

$$(x-1)y'' - xy' + y = 0.$$

Then find the general solution of (5.7.16).

**Solution** We set

$$y_p = u_1x + u_2e^x,$$

where

$$\begin{aligned} u_1'x + u_2'e^x &= 0 \\ u_1' + u_2'e^x &= \frac{(x-1)^2}{x-1} = x-1. \end{aligned}$$

Subtracting the first equation from the second yields  $-u_1'(x-1) = x-1$ , so  $u_1' = -1$ . From this and the first equation,  $u_2' = -xe^{-x}u_1' = xe^{-x}$ . Integrating and taking the constants of integration to be zero yields

$$u_1 = -x \quad \text{and} \quad u_2 = -(x+1)e^{-x}.$$

Therefore

$$y_p = u_1x + u_2e^x = (-x)x + (-(x+1)e^{-x})e^x = -x^2 - x - 1,$$

so the general solution of (5.7.16) is

$$y = y_p + c_1x + c_2e^x = -x^2 - x - 1 + c_1x + c_2e^x = -x^2 - 1 + (c_1 - 1)x + c_2e^x. \quad (5.7.17)$$

However, since  $c_1$  is an arbitrary constant, so is  $c_1 - 1$ ; therefore, we improve the appearance of this result by renaming the constant and writing the general solution as

$$y = -x^2 - 1 + c_1x + c_2e^x. \quad \blacksquare \quad (5.7.18)$$

There's nothing *wrong* with leaving the general solution of (5.7.16) in the form (5.7.17); however, we think you'll agree that (5.7.18) is preferable. We can also view the transition from (5.7.17) to (5.7.18) differently. In this example the particular solution  $y_p = -x^2 - x - 1$  contained the term  $-x$ , which satisfies the complementary equation. We can drop this term and redefine  $y_p = -x^2 - 1$ , since  $-x^2 - x - 1$  is a solution of (5.7.16) and  $x$  is a solution of the complementary equation; hence,  $-x^2 - 1 = (-x^2 - x - 1) + x$  is also a solution of (5.7.16). In general, it's always legitimate to drop linear combinations of  $\{y_1, y_2\}$  from particular solutions obtained by variation of parameters. (See Exercise 36 for a general discussion of this question.) We'll do this in the following examples and in the answers to exercises that ask for a particular solution. Therefore, don't be concerned if your answer to such an exercise differs from ours only by a solution of the complementary equation.



**Example 5.7.3** Find a particular solution of

$$y'' + 3y' + 2y = \frac{1}{1 + e^x}. \quad (5.7.19)$$

Then find the general solution.

**Solution**

The characteristic polynomial of the complementary equation

$$y'' + 3y' + 2y = 0 \quad (5.7.20)$$

is  $p(r) = r^2 + 3r + 2 = (r + 1)(r + 2)$ , so  $y_1 = e^{-x}$  and  $y_2 = e^{-2x}$  form a fundamental set of solutions of (5.7.20). We look for a particular solution of (5.7.19) in the form

$$y_p = u_1 e^{-x} + u_2 e^{-2x},$$

where

$$\begin{aligned} u_1' e^{-x} + u_2' e^{-2x} &= 0 \\ -u_1' e^{-x} - 2u_2' e^{-2x} &= \frac{1}{1 + e^x}. \end{aligned}$$

Adding these two equations yields

$$-u_2' e^{-2x} = \frac{1}{1 + e^x}, \quad \text{so} \quad u_2' = -\frac{e^{2x}}{1 + e^x}.$$

From the first equation,

$$u_1' = -u_2' e^{-x} = \frac{e^x}{1 + e^x}.$$

Integrating by means of the substitution  $v = e^x$  and taking the constants of integration to be zero yields

$$u_1 = \int \frac{e^x}{1 + e^x} dx = \int \frac{dv}{1 + v} = \ln(1 + v) = \ln(1 + e^x)$$

and

$$\begin{aligned} u_2 &= -\int \frac{e^{2x}}{1 + e^x} dx = -\int \frac{v}{1 + v} dv = \int \left[ \frac{1}{1 + v} - 1 \right] dv \\ &= \ln(1 + v) - v = \ln(1 + e^x) - e^x. \end{aligned}$$

Therefore

$$\begin{aligned} y_p &= u_1 e^{-x} + u_2 e^{-2x} \\ &= [\ln(1 + e^x)] e^{-x} + [\ln(1 + e^x) - e^x] e^{-2x}, \end{aligned}$$

so

$$y_p = (e^{-x} + e^{-2x}) \ln(1 + e^x) - e^{-x}.$$

Since the last term on the right satisfies the complementary equation, we drop it and redefine

$$y_p = (e^{-x} + e^{-2x}) \ln(1 + e^x).$$

The general solution of (5.7.19) is

$$y = y_p + c_1 e^{-x} + c_2 e^{-2x} = (e^{-x} + e^{-2x}) \ln(1 + e^x) + c_1 e^{-x} + c_2 e^{-2x}.$$

**Example 5.7.4** Solve the initial value problem

$$(x^2 - 1)y'' + 4xy' + 2y = \frac{2}{x+1}, \quad y(0) = -1, \quad y'(0) = -5, \quad (5.7.21)$$

given that

$$y_1 = \frac{1}{x-1} \quad \text{and} \quad y_2 = \frac{1}{x+1}$$

are solutions of the complementary equation

$$(x^2 - 1)y'' + 4xy' + 2y = 0.$$

**Solution** We first use variation of parameters to find a particular solution of

$$(x^2 - 1)y'' + 4xy' + 2y = \frac{2}{x+1}$$

on  $(-1, 1)$  in the form

$$y_p = \frac{u_1}{x-1} + \frac{u_2}{x+1},$$

where

$$\begin{aligned} \frac{u_1'}{x-1} + \frac{u_2'}{x+1} &= 0 \\ -\frac{u_1'}{(x-1)^2} - \frac{u_2'}{(x+1)^2} &= \frac{2}{(x+1)(x^2-1)}. \end{aligned} \quad (5.7.22)$$

Multiplying the first equation by  $1/(x-1)$  and adding the result to the second equation yields

$$\left[ \frac{1}{x^2-1} - \frac{1}{(x+1)^2} \right] u_2' = \frac{2}{(x+1)(x^2-1)}. \quad (5.7.23)$$

Since

$$\left[ \frac{1}{x^2-1} - \frac{1}{(x+1)^2} \right] = \frac{(x+1) - (x-1)}{(x+1)(x^2-1)} = \frac{2}{(x+1)(x^2-1)},$$

(5.7.23) implies that  $u_2' = 1$ . From (5.7.22),

$$u_1' = -\frac{x-1}{x+1}u_2' = -\frac{x-1}{x+1}.$$

Integrating and taking the constants of integration to be zero yields

$$\begin{aligned} u_1 &= -\int \frac{x-1}{x+1} dx = -\int \frac{x+1-2}{x+1} dx \\ &= \int \left[ \frac{2}{x+1} - 1 \right] dx = 2 \ln(x+1) - x \end{aligned}$$

and

$$u_2 = \int dx = x.$$

Therefore

$$\begin{aligned} y_p &= \frac{u_1}{x-1} + \frac{u_2}{x+1} = [2\ln(x+1) - x] \frac{1}{x-1} + x \frac{1}{x+1} \\ &= \frac{2\ln(x+1)}{x-1} + x \left[ \frac{1}{x+1} - \frac{1}{x-1} \right] = \frac{2\ln(x+1)}{x-1} - \frac{2x}{(x+1)(x-1)}. \end{aligned}$$

However, since

$$\frac{2x}{(x+1)(x-1)} = \left[ \frac{1}{x+1} + \frac{1}{x-1} \right]$$

is a solution of the complementary equation, we redefine

$$y_p = \frac{2\ln(x+1)}{x-1}.$$

Therefore the general solution of (5.7.24) is

$$y = \frac{2\ln(x+1)}{x-1} + \frac{c_1}{x-1} + \frac{c_2}{x+1}. \quad (5.7.24)$$

Differentiating this yields

$$y' = \frac{2}{x^2-1} - \frac{2\ln(x+1)}{(x-1)^2} - \frac{c_1}{(x-1)^2} - \frac{c_2}{(x+1)^2}.$$

Setting  $x = 0$  in the last two equations and imposing the initial conditions  $y(0) = -1$  and  $y'(0) = -5$  yields the system

$$\begin{aligned} -c_1 + c_2 &= -1 \\ -2 - c_1 - c_2 &= -5. \end{aligned}$$

The solution of this system is  $c_1 = 2$ ,  $c_2 = 1$ . Substituting these into (5.7.24) yields

$$\begin{aligned} y &= \frac{2\ln(x+1)}{x-1} + \frac{2}{x-1} + \frac{1}{x+1} \\ &= \frac{2\ln(x+1)}{x-1} + \frac{3x+1}{x^2-1} \end{aligned}$$

as the solution of (5.7.21). Figure 5.7.1 is a graph of the solution.

### Comparison of Methods

We've now considered three methods for solving nonhomogeneous linear equations: undetermined coefficients, reduction of order, and variation of parameters. It's natural to ask which method is best for a given problem. The method of undetermined coefficients should be used for constant coefficient equations with forcing functions that are linear combinations of polynomials multiplied by functions of the form  $e^{\alpha x}$ ,  $e^{\lambda x} \cos \omega x$ , or  $e^{\lambda x} \sin \omega x$ . Although the other two methods can be used to solve such problems, they will be more difficult except in the most trivial cases, because of the integrations involved.

If the equation isn't a constant coefficient equation or the forcing function isn't of the form just specified, the method of undetermined coefficients does not apply and the choice is necessarily between the other two methods. The case could be made that reduction of order is better because it requires only one solution of the complementary equation while variation of parameters requires two. However, variation of parameters will probably be easier if you already know a fundamental set of solutions of the complementary equation.

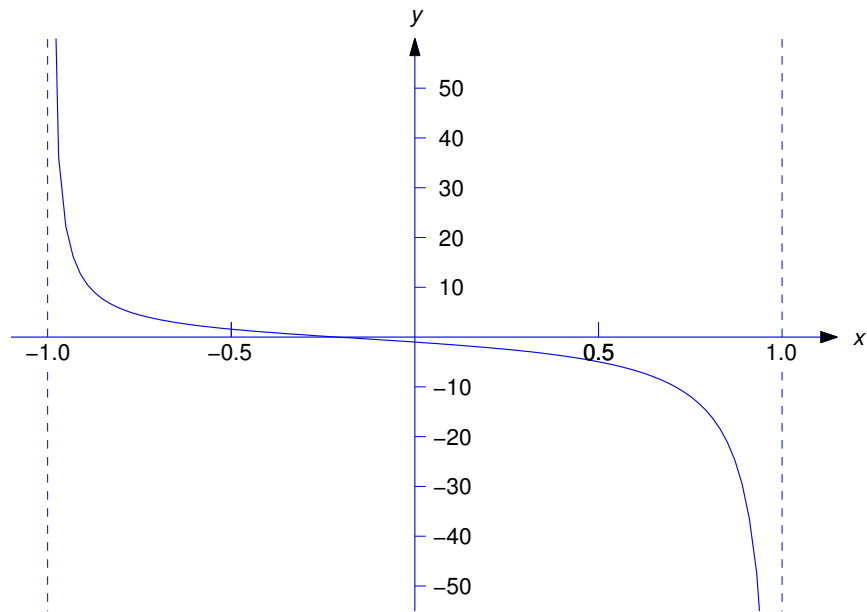

Figure 5.7.1  $y = \frac{2 \ln(x+1)}{x-1} + \frac{3x+1}{x^2-1}$

### 5.7 Exercises

In Exercises 1–6 use variation of parameters to find a particular solution.

1.  $y'' + 9y = \tan 3x$
2.  $y'' + 4y = \sin 2x \sec^2 2x$
3.  $y'' - 3y' + 2y = \frac{4}{1 + e^{-x}}$
4.  $y'' - 2y' + 2y = 3e^x \sec x$
5.  $y'' - 2y' + y = 14x^{3/2}e^x$
6.  $y'' - y = \frac{4e^{-x}}{1 - e^{-2x}}$

In Exercises 7–29 use variation of parameters to find a particular solution, given the solutions  $y_1, y_2$  of the complementary equation.

7.  $x^2y'' + xy' - y = 2x^2 + 2$ ;  $y_1 = x, y_2 = \frac{1}{x}$
8.  $xy'' + (2 - 2x)y' + (x - 2)y = e^{2x}$ ;  $y_1 = e^x, y_2 = \frac{e^x}{x}$
9.  $4x^2y'' + (4x - 8x^2)y' + (4x^2 - 4x - 1)y = 4x^{1/2}e^x, x > 0$ ;  
 $y_1 = x^{1/2}e^x, y_2 = x^{-1/2}e^x$
10.  $y'' + 4xy' + (4x^2 + 2)y = 4e^{-x(x+2)}$ ;  $y_1 = e^{-x^2}, y_2 = xe^{-x^2}$
11.  $x^2y'' - 4xy' + 6y = x^{5/2}, x > 0$ ;  $y_1 = x^2, y_2 = x^3$
12.  $x^2y'' - 3xy' + 3y = 2x^4 \sin x$ ;  $y_1 = x, y_2 = x^3$
13.  $(2x + 1)y'' - 2y' - (2x + 3)y = (2x + 1)^2e^{-x}$ ;  $y_1 = e^{-x}, y_2 = xe^{-x}$
14.  $4xy'' + 2y' + y = \sin \sqrt{x}$ ;  $y_1 = \cos \sqrt{x}, y_2 = \sin \sqrt{x}$
15.  $xy'' - (2x + 2)y' + (x + 2)y = 6x^3e^x$ ;  $y_1 = e^x, y_2 = x^3e^x$
16.  $x^2y'' - (2a - 1)xy' + a^2y = x^{a+1}$ ;  $y_1 = x^a, y_2 = x^a \ln x$
17.  $x^2y'' - 2xy' + (x^2 + 2)y = x^3 \cos x$ ;  $y_1 = x \cos x, y_2 = x \sin x$
18.  $xy'' - y' - 4x^3y = 8x^5$ ;  $y_1 = e^{x^2}, y_2 = e^{-x^2}$
19.  $(\sin x)y'' + (2 \sin x - \cos x)y' + (\sin x - \cos x)y = e^{-x}$ ;  $y_1 = e^{-x}, y_2 = e^{-x} \cos x$
20.  $4x^2y'' - 4xy' + (3 - 16x^2)y = 8x^{5/2}$ ;  $y_1 = \sqrt{x}e^{2x}, y_2 = \sqrt{x}e^{-2x}$
21.  $4x^2y'' - 4xy' + (4x^2 + 3)y = x^{7/2}$ ;  $y_1 = \sqrt{x} \sin x, y_2 = \sqrt{x} \cos x$
22.  $x^2y'' - 2xy' - (x^2 - 2)y = 3x^4$ ;  $y_1 = xe^x, y_2 = xe^{-x}$
23.  $x^2y'' - 2x(x + 1)y' + (x^2 + 2x + 2)y = x^3e^x$ ;  $y_1 = xe^x, y_2 = x^2e^x$
24.  $x^2y'' - xy' - 3y = x^{3/2}$ ;  $y_1 = 1/x, y_2 = x^3$
25.  $x^2y'' - x(x + 4)y' + 2(x + 3)y = x^4e^x$ ;  $y_1 = x^2, y_2 = x^2e^x$
26.  $x^2y'' - 2x(x + 2)y' + (x^2 + 4x + 6)y = 2xe^x$ ;  $y_1 = x^2e^x, y_2 = x^3e^x$
27.  $x^2y'' - 4xy' + (x^2 + 6)y = x^4$ ;  $y_1 = x^2 \cos x, y_2 = x^2 \sin x$
28.  $(x - 1)y'' - xy' + y = 2(x - 1)^2e^x$ ;  $y_1 = x, y_2 = e^x$
29.  $4x^2y'' - 4x(x + 1)y' + (2x + 3)y = x^{5/2}e^x$ ;  $y_1 = \sqrt{x}, y_2 = \sqrt{x}e^x$

In Exercises 30–32 use variation of parameters to solve the initial value problem, given  $y_1, y_2$  are solutions of the complementary equation.

30.  $(3x - 1)y'' - (3x + 2)y' - (6x - 8)y = (3x - 1)^2e^{2x}, y(0) = 1, y'(0) = 2$ ;  
 $y_1 = e^{2x}, y_2 = xe^{-x}$
31.  $(x - 1)^2y'' - 2(x - 1)y' + 2y = (x - 1)^2, y(0) = 3, y'(0) = -6$ ;  
 $y_1 = x - 1, y_2 = x^2 - 1$
32.  $(x - 1)^2y'' - (x^2 - 1)y' + (x + 1)y = (x - 1)^3e^x, y(0) = 4, y'(0) = -6$ ;  
 $y_1 = (x - 1)e^x, y_2 = x - 1$

In Exercises 33–35 use variation of parameters to solve the initial value problem and graph the solution, given that  $y_1, y_2$  are solutions of the complementary equation.

33. C/G  $(x^2 - 1)y'' + 4xy' + 2y = 2x, \quad y(0) = 0, \quad y'(0) = -2; \quad y_1 = \frac{1}{x-1}, \quad y_2 = \frac{1}{x+1}$

34. C/G  $x^2y'' + 2xy' - 2y = -2x^2, \quad y(1) = 1, \quad y'(1) = -1; \quad y_1 = x, \quad y_2 = \frac{1}{x^2}$

35. C/G  $(x+1)(2x+3)y'' + 2(x+2)y' - 2y = (2x+3)^2, \quad y(0) = 0, \quad y'(0) = 0;$   
 $y_1 = x+2, \quad y_2 = \frac{1}{x+1}$

36. Suppose

$$y_p = \bar{y} + a_1y_1 + a_2y_2$$

is a particular solution of

$$P_0(x)y'' + P_1(x)y' + P_2(x)y = F(x), \quad (\text{A})$$

where  $y_1$  and  $y_2$  are solutions of the complementary equation

$$P_0(x)y'' + P_1(x)y' + P_2(x)y = 0.$$

Show that  $\bar{y}$  is also a solution of (A).

37. Suppose  $p, q,$  and  $f$  are continuous on  $(a, b)$  and let  $x_0$  be in  $(a, b)$ . Let  $y_1$  and  $y_2$  be the solutions of

$$y'' + p(x)y' + q(x)y = 0$$

such that

$$y_1(x_0) = 1, \quad y_1'(x_0) = 0, \quad y_2(x_0) = 0, \quad y_2'(x_0) = 1.$$

Use variation of parameters to show that the solution of the initial value problem

$$y'' + p(x)y' + q(x)y = f(x), \quad y(x_0) = k_0, \quad y'(x_0) = k_1,$$

is

$$y(x) = k_0y_1(x) + k_1y_2(x) + \int_{x_0}^x (y_1(t)y_2(x) - y_1(x)y_2(t)) f(t) \exp\left(\int_{x_0}^t p(s) ds\right) dt.$$

HINT: Use Abel's formula for the Wronskian of  $\{y_1, y_2\}$ , and integrate  $u_1'$  and  $u_2'$  from  $x_0$  to  $x$ . Show also that

$$y'(x) = k_0y_1'(x) + k_1y_2'(x) + \int_{x_0}^x (y_1(t)y_2'(x) - y_1'(x)y_2(t)) f(t) \exp\left(\int_{x_0}^t p(s) ds\right) dt.$$

38. Suppose  $f$  is continuous on an open interval that contains  $x_0 = 0$ . Use variation of parameters to find a formula for the solution of the initial value problem

$$y'' - y = f(x), \quad y(0) = k_0, \quad y'(0) = k_1.$$

39. Suppose  $f$  is continuous on  $(a, \infty)$ , where  $a < 0$ , so  $x_0 = 0$  is in  $(a, \infty)$ .

- (a) Use variation of parameters to find a formula for the solution of the initial value problem

$$y'' + y = f(x), \quad y(0) = k_0, \quad y'(0) = k_1.$$

HINT: You will need the addition formulas for the sine and cosine:

$$\begin{aligned} \sin(A + B) &= \sin A \cos B + \cos A \sin B \\ \cos(A + B) &= \cos A \cos B - \sin A \sin B. \end{aligned}$$

For the rest of this exercise assume that the improper integral  $\int_0^\infty f(t) dt$  is absolutely convergent.

- (b) Show that if  $y$  is a solution of

$$y'' + y = f(x) \tag{A}$$

on  $(a, \infty)$ , then

$$\lim_{x \rightarrow \infty} (y(x) - A_0 \cos x - A_1 \sin x) = 0 \tag{B}$$

and

$$\lim_{x \rightarrow \infty} (y'(x) + A_0 \sin x - A_1 \cos x) = 0, \tag{C}$$

where

$$A_0 = k_0 - \int_0^\infty f(t) \sin t dt \quad \text{and} \quad A_1 = k_1 + \int_0^\infty f(t) \cos t dt.$$

HINT: Recall from calculus that if  $\int_0^\infty f(t) dt$  converges absolutely, then  $\lim_{x \rightarrow \infty} \int_x^\infty |f(t)| dt = 0$ .

- (c) Show that if  $A_0$  and  $A_1$  are arbitrary constants, then there's a unique solution of  $y'' + y = f(x)$  on  $(a, \infty)$  that satisfies (B) and (C).





# CHAPTER 6

## Applications of Linear Second Order Equations

IN THIS CHAPTER we study applications of linear second order equations.

SECTIONS 6.1 AND 6.2 is about spring–mass systems.

SECTION 6.2 is about *RLC* circuits, the electrical analogs of spring–mass systems.

SECTION 6.3 is about motion of an object under a central force, which is particularly relevant in the space age, since, for example, a satellite moving in orbit subject only to Earth's gravity is experiencing motion under a central force.

## 6.1 SPRING PROBLEMS I

We consider the motion of an object of mass  $m$ , suspended from a spring of negligible mass. We say that the spring–mass system is in *equilibrium* when the object is at rest and the forces acting on it sum to zero. The position of the object in this case is the *equilibrium position*. We define  $y$  to be the displacement of the object from its equilibrium position (Figure 6.1.1), measured positive upward.

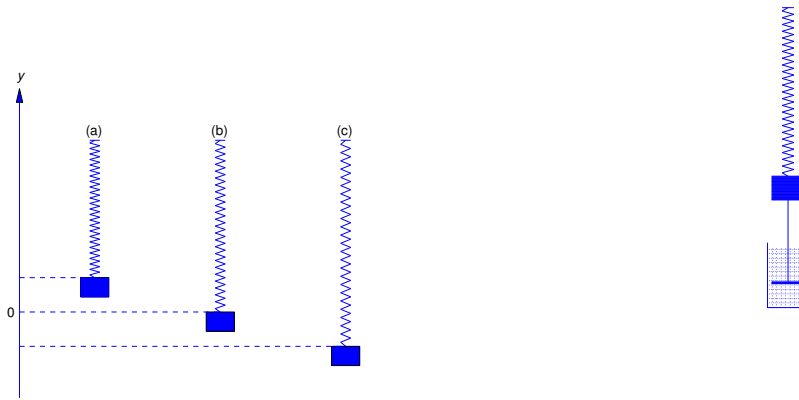

Figure 6.1.1 (a)  $y > 0$  (b)  $y = 0$ , (c)  $y < 0$  Figure 6.1.2 A spring – mass system with damping

Our model accounts for the following kinds of forces acting on the object:

- The force  $-mg$ , due to gravity.
- A force  $F_s$  exerted by the spring resisting change in its length. The *natural length* of the spring is its length with no mass attached. We assume that the spring obeys *Hooke's law*: If the length of the spring is changed by an amount  $\Delta L$  from its natural length, then the spring exerts a force  $F_s = k\Delta L$ , where  $k$  is a positive number called the *spring constant*. If the spring is stretched then  $\Delta L > 0$  and  $F_s > 0$ , so the spring force is upward, while if the spring is compressed then  $\Delta L < 0$  and  $F_s < 0$ , so the spring force is downward.
- A *damping force*  $F_d = -cy'$  that resists the motion with a force proportional to the velocity of the object. It may be due to air resistance or friction in the spring. However, a convenient way to visualize a damping force is to assume that the object is rigidly attached to a piston with negligible mass immersed in a cylinder (called a *dashpot*) filled with a viscous liquid (Figure 6.1.2). As the piston moves, the liquid exerts a damping force. We say that the motion is *undamped* if  $c = 0$ , or *damped* if  $c > 0$ .
- An external force  $F$ , other than the force due to gravity, that may vary with  $t$ , but is independent of displacement and velocity. We say that the motion is *free* if  $F \equiv 0$ , or *forced* if  $F \not\equiv 0$ .

From Newton's second law of motion,

$$my'' = -mg + F_d + F_s + F = -mg - cy' + F_s + F. \quad (6.1.1)$$

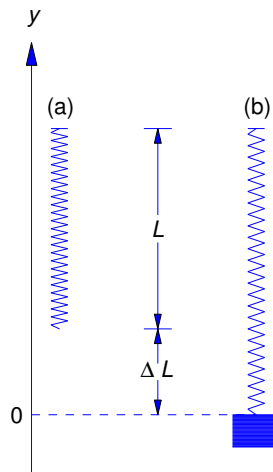

Figure 6.1.3 (a) Natural length of spring (b) Spring stretched by mass

We must now relate  $F_s$  to  $y$ . In the absence of external forces the object stretches the spring by an amount  $\Delta l$  to assume its equilibrium position (Figure 6.1.3). Since the sum of the forces acting on the object is then zero, Hooke's Law implies that  $mg = k\Delta l$ . If the object is displaced  $y$  units from its equilibrium position, the total change in the length of the spring is  $\Delta L = \Delta l - y$ , so Hooke's law implies that

$$F_s = k\Delta L = k\Delta l - ky.$$

Substituting this into (6.1.1) yields

$$my'' = -mg - cy' + k\Delta L - ky + F.$$

Since  $mg = k\Delta l$  this can be written as

$$my'' + cy' + ky = F. \quad (6.1.2)$$

We call this *the equation of motion*.

### Simple Harmonic Motion

Throughout the rest of this section we'll consider spring-mass systems without damping; that is,  $c = 0$ . We'll consider systems with damping in the next section.

We first consider the case where the motion is also free; that is,  $F=0$ . We begin with an example.

**Example 6.1.1** An object stretches a spring 6 inches in equilibrium.

- Set up the equation of motion and find its general solution.
- Find the displacement of the object for  $t > 0$  if it's initially displaced 18 inches above equilibrium and given a downward velocity of 3 ft/s.

**SOLUTION(a)** Setting  $c = 0$  and  $F = 0$  in (6.1.2) yields the equation of motion

$$my'' + ky = 0,$$

which we rewrite as

$$y'' + \frac{k}{m}y = 0. \quad (6.1.3)$$

Although we would need the weight of the object to obtain  $k$  from the equation  $mg = k\Delta l$  we can obtain  $k/m$  from  $\Delta l$  alone; thus,  $k/m = g/\Delta l$ . Consistent with the units used in the problem statement, we take  $g = 32 \text{ ft/s}^2$ . Although  $\Delta l$  is stated in inches, we must convert it to feet to be consistent with this choice of  $g$ ; that is,  $\Delta l = 1/2 \text{ ft}$ . Therefore

$$\frac{k}{m} = \frac{32}{1/2} = 64$$

and (6.1.3) becomes

$$y'' + 64y = 0. \quad (6.1.4)$$

The characteristic equation of (6.1.4) is

$$r^2 + 64 = 0,$$

which has the zeros  $r = \pm 8i$ . Therefore the general solution of (6.1.4) is

$$y = c_1 \cos 8t + c_2 \sin 8t. \quad (6.1.5)$$

**SOLUTION(b)** The initial upward displacement of 18 inches is positive and must be expressed in feet. The initial downward velocity is negative; thus,

$$y(0) = \frac{3}{2} \quad \text{and} \quad y'(0) = -3.$$

Differentiating (6.1.5) yields

$$y' = -8c_1 \sin 8t + 8c_2 \cos 8t. \quad (6.1.6)$$

Setting  $t = 0$  in (6.1.5) and (6.1.6) and imposing the initial conditions shows that  $c_1 = 3/2$  and  $c_2 = -3/8$ . Therefore

$$y = \frac{3}{2} \cos 8t - \frac{3}{8} \sin 8t,$$

where  $y$  is in feet (Figure 6.1.4).

We'll now consider the equation

$$my'' + ky = 0$$

where  $m$  and  $k$  are arbitrary positive numbers. Dividing through by  $m$  and defining  $\omega_0 = \sqrt{k/m}$  yields

$$y'' + \omega_0^2 y = 0.$$

The general solution of this equation is

$$y = c_1 \cos \omega_0 t + c_2 \sin \omega_0 t. \quad (6.1.7)$$

We can rewrite this in a more useful form by defining

$$R = \sqrt{c_1^2 + c_2^2}, \quad (6.1.8)$$

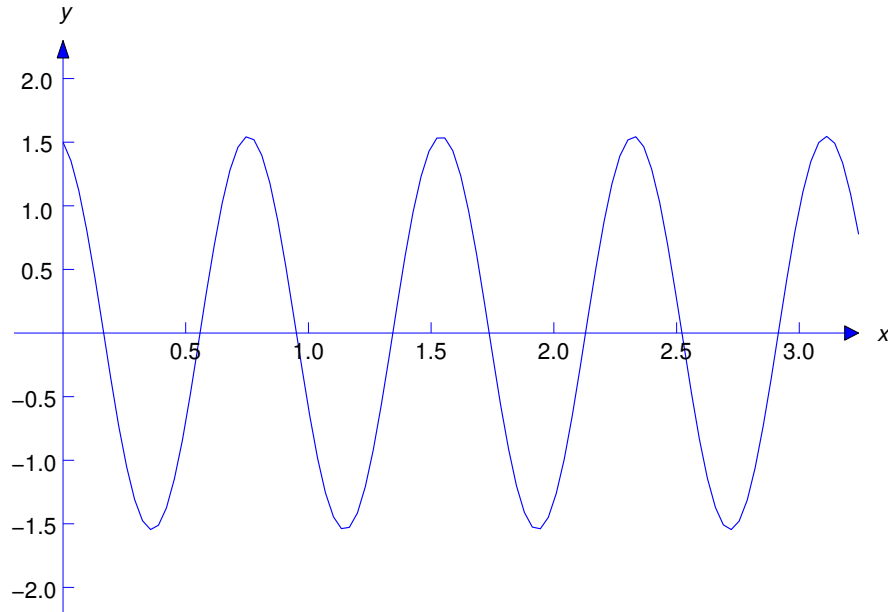

Figure 6.1.4  $y = \frac{3}{2} \cos 8t - \frac{3}{8} \sin 8t$

and

$$c_1 = R \cos \phi \quad \text{and} \quad c_2 = R \sin \phi. \quad (6.1.9)$$

Substituting from (6.1.9) into (6.1.7) and applying the identity

$$\cos \omega_0 t \cos \phi + \sin \omega_0 t \sin \phi = \cos(\omega_0 t - \phi)$$

yields

$$y = R \cos(\omega_0 t - \phi). \quad (6.1.10)$$

From (6.1.8) and (6.1.9) we see that the  $R$  and  $\phi$  can be interpreted as polar coordinates of the point with rectangular coordinates  $(c_1, c_2)$  (Figure 6.1.5). Given  $c_1$  and  $c_2$ , we can compute  $R$  from (6.1.8). From (6.1.8) and (6.1.9), we see that  $\phi$  is related to  $c_1$  and  $c_2$  by

$$\cos \phi = \frac{c_1}{\sqrt{c_1^2 + c_2^2}} \quad \text{and} \quad \sin \phi = \frac{c_2}{\sqrt{c_1^2 + c_2^2}}.$$

There are infinitely many angles  $\phi$ , differing by integer multiples of  $2\pi$ , that satisfy these equations. We will always choose  $\phi$  so that  $-\pi \leq \phi < \pi$ .

The motion described by (6.1.7) or (6.1.10) is *simple harmonic motion*. We see from either of these equations that the motion is periodic, with period

$$T = 2\pi/\omega_0.$$

This is the time required for the object to complete one full cycle of oscillation (for example, to move from its highest position to its lowest position and back to its highest position). Since the highest and lowest positions of the object are  $y = R$  and  $y = -R$ , we say that  $R$  is the *amplitude* of the oscillation. The

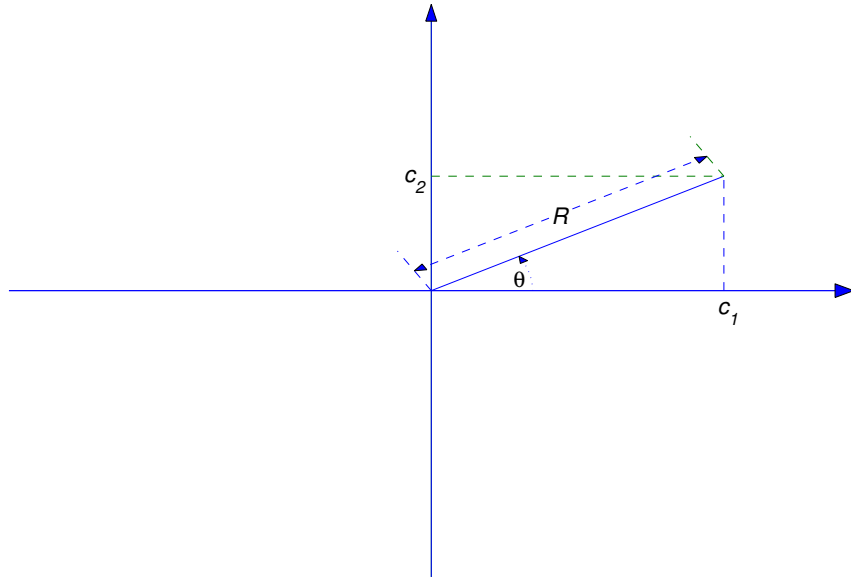

Figure 6.1.5  $R = \sqrt{c_1^2 + c_2^2}$ ;  $c_1 = R \cos \phi$ ;  $c_2 = R \sin \phi$

angle  $\phi$  in (6.1.10) is the *phase angle*. It's measured in radians. Equation (6.1.10) is the *amplitude–phase form* of the displacement. If  $t$  is in seconds then  $\omega_0$  is in radians per second (rad/s); it's the *frequency* of the motion. It is also called the *natural frequency* of the spring–mass system without damping.

**Example 6.1.2** We found the displacement of the object in Example 6.1.1 to be

$$y = \frac{3}{2} \cos 8t - \frac{3}{8} \sin 8t.$$

Find the frequency, period, amplitude, and phase angle of the motion.

**Solution** The frequency is  $\omega_0 = 8$  rad/s, and the period is  $T = 2\pi/\omega_0 = \pi/4$  s. Since  $c_1 = 3/2$  and  $c_2 = -3/8$ , the amplitude is

$$R = \sqrt{c_1^2 + c_2^2} = \sqrt{\left(\frac{3}{2}\right)^2 + \left(\frac{3}{8}\right)^2} = \frac{3}{8}\sqrt{17}.$$

The phase angle is determined by

$$\cos \phi = \frac{\frac{3}{2}}{\frac{3}{8}\sqrt{17}} = \frac{4}{\sqrt{17}} \quad (6.1.11)$$

and

$$\sin \phi = \frac{-\frac{3}{8}}{\frac{3}{8}\sqrt{17}} = -\frac{1}{\sqrt{17}}. \quad (6.1.12)$$

Using a calculator, we see from (6.1.11) that

$$\phi \approx \pm .245 \text{ rad.}$$

Since  $\sin \phi < 0$  (see (6.1.12)), the minus sign applies here; that is,

$$\phi \approx -.245 \text{ rad.}$$

**Example 6.1.3** The natural length of a spring is 1 m. An object is attached to it and the length of the spring increases to 102 cm when the object is in equilibrium. Then the object is initially displaced downward 1 cm and given an upward velocity of 14 cm/s. Find the displacement for  $t > 0$ . Also, find the natural frequency, period, amplitude, and phase angle of the resulting motion. Express the answers in cgs units.

**Solution** In cgs units  $g = 980 \text{ cm/s}^2$ . Since  $\Delta l = 2 \text{ cm}$ ,  $\omega_0^2 = g/\Delta l = 490$ . Therefore

$$y'' + 490y = 0, \quad y(0) = -1, \quad y'(0) = 14.$$

The general solution of the differential equation is

$$y = c_1 \cos 7\sqrt{10}t + c_2 \sin 7\sqrt{10}t,$$

so

$$y' = 7\sqrt{10} \left( -c_1 \sin 7\sqrt{10}t + c_2 \cos 7\sqrt{10}t \right).$$

Substituting the initial conditions into the last two equations yields  $c_1 = -1$  and  $c_2 = 2/\sqrt{10}$ . Hence,

$$y = -\cos 7\sqrt{10}t + \frac{2}{\sqrt{10}} \sin 7\sqrt{10}t.$$

The frequency is  $7\sqrt{10}$  rad/s, and the period is  $T = 2\pi/(7\sqrt{10})$  s. The amplitude is

$$R = \sqrt{c_1^2 + c_2^2} = \sqrt{(-1)^2 + \left(\frac{2}{\sqrt{10}}\right)^2} = \sqrt{\frac{7}{5}} \text{ cm.}$$

The phase angle is determined by

$$\cos \phi = \frac{c_1}{R} = -\sqrt{\frac{5}{7}} \quad \text{and} \quad \sin \phi = \frac{c_2}{R} = \sqrt{\frac{2}{7}}.$$

Therefore  $\phi$  is in the second quadrant and

$$\phi = \cos^{-1} \left( -\sqrt{\frac{5}{7}} \right) \approx 2.58 \text{ rad.}$$

### Undamped Forced Oscillation

In many mechanical problems a device is subjected to periodic external forces. For example, soldiers marching in cadence on a bridge cause periodic disturbances in the bridge, and the engines of a propeller driven aircraft cause periodic disturbances in its wings. In the absence of sufficient damping forces, such disturbances – even if small in magnitude – can cause structural breakdown if they are at certain critical frequencies. To illustrate, this we'll consider the motion of an object in a spring–mass system without damping, subject to an external force

$$F(t) = F_0 \cos \omega t$$

where  $F_0$  is a constant. In this case the equation of motion (6.1.2) is

$$my'' + ky = F_0 \cos \omega t,$$

which we rewrite as

$$y'' + \omega_0^2 y = \frac{F_0}{m} \cos \omega t \quad (6.1.13)$$

with  $\omega_0 = \sqrt{k/m}$ . We'll see from the next two examples that the solutions of (6.1.13) with  $\omega \neq \omega_0$  behave very differently from the solutions with  $\omega = \omega_0$ .

**Example 6.1.4** Solve the initial value problem

$$y'' + \omega_0^2 y = \frac{F_0}{m} \cos \omega t, \quad y(0) = 0, \quad y'(0) = 0, \quad (6.1.14)$$

given that  $\omega \neq \omega_0$ .

**Solution** We first obtain a particular solution of (6.1.13) by the method of undetermined coefficients. Since  $\omega \neq \omega_0$ ,  $\cos \omega t$  isn't a solution of the complementary equation

$$y'' + \omega_0^2 y = 0.$$

Therefore (6.1.13) has a particular solution of the form

$$y_p = A \cos \omega t + B \sin \omega t.$$

Since

$$\begin{aligned} y_p'' &= -\omega^2 (A \cos \omega t + B \sin \omega t), \\ y_p'' + \omega_0^2 y_p &= \frac{F_0}{m} \cos \omega t \end{aligned}$$

if and only if

$$(\omega_0^2 - \omega^2) (A \cos \omega t + B \sin \omega t) = \frac{F_0}{m} \cos \omega t.$$

This holds if and only if

$$A = \frac{F_0}{m(\omega_0^2 - \omega^2)} \quad \text{and} \quad B = 0,$$

so

$$y_p = \frac{F_0}{m(\omega_0^2 - \omega^2)} \cos \omega t.$$

The general solution of (6.1.13) is

$$y = \frac{F_0}{m(\omega_0^2 - \omega^2)} \cos \omega t + c_1 \cos \omega_0 t + c_2 \sin \omega_0 t, \quad (6.1.15)$$

so

$$y' = \frac{-\omega F_0}{m(\omega_0^2 - \omega^2)} \sin \omega t + \omega_0 (-c_1 \sin \omega_0 t + c_2 \cos \omega_0 t).$$

The initial conditions  $y(0) = 0$  and  $y'(0) = 0$  in (6.1.14) imply that

$$c_1 = -\frac{F_0}{m(\omega_0^2 - \omega^2)} \quad \text{and} \quad c_2 = 0.$$



Substituting these into (6.1.15) yields

$$y = \frac{F_0}{m(\omega_0^2 - \omega^2)}(\cos \omega t - \cos \omega_0 t). \quad (6.1.16)$$

It is revealing to write this in a different form. We start with the trigonometric identities

$$\begin{aligned} \cos(\alpha - \beta) &= \cos \alpha \cos \beta + \sin \alpha \sin \beta \\ \cos(\alpha + \beta) &= \cos \alpha \cos \beta - \sin \alpha \sin \beta. \end{aligned}$$

Subtracting the second identity from the first yields

$$\cos(\alpha - \beta) - \cos(\alpha + \beta) = 2 \sin \alpha \sin \beta \quad (6.1.17)$$

Now let

$$\alpha - \beta = \omega t \quad \text{and} \quad \alpha + \beta = \omega_0 t, \quad (6.1.18)$$

so that

$$\alpha = \frac{(\omega_0 + \omega)t}{2} \quad \text{and} \quad \beta = \frac{(\omega_0 - \omega)t}{2}. \quad (6.1.19)$$

Substituting (6.1.18) and (6.1.19) into (6.1.17) yields

$$\cos \omega t - \cos \omega_0 t = 2 \sin \frac{(\omega_0 - \omega)t}{2} \sin \frac{(\omega_0 + \omega)t}{2},$$

and substituting this into (6.1.16) yields

$$y = R(t) \sin \frac{(\omega_0 + \omega)t}{2}, \quad (6.1.20)$$

where

$$R(t) = \frac{2F_0}{m(\omega_0^2 - \omega^2)} \sin \frac{(\omega_0 - \omega)t}{2}. \quad (6.1.21)$$

From (6.1.20) we can regard  $y$  as a sinusoidal variation with frequency  $(\omega_0 + \omega)/2$  and variable amplitude  $|R(t)|$ . In Figure 6.1.6 the dashed curve above the  $t$  axis is  $y = |R(t)|$ , the dashed curve below the  $t$  axis is  $y = -|R(t)|$ , and the displacement  $y$  appears as an oscillation bounded by them. The oscillation of  $y$  for  $t$  on an interval between successive zeros of  $R(t)$  is called a *beat*.

You can see from (6.1.20) and (6.1.21) that

$$|y(t)| \leq \frac{2|F_0|}{m|\omega_0^2 - \omega^2|};$$

moreover, if  $\omega + \omega_0$  is sufficiently large compared with  $\omega - \omega_0$ , then  $|y|$  assumes values close to (perhaps equal to) this upper bound during each beat. However, the oscillation remains bounded for all  $t$ . (This assumes that the spring can withstand deflections of this size and continue to obey Hooke's law.) The next example shows that this isn't so if  $\omega = \omega_0$ .

**Example 6.1.5** Find the general solution of

$$y'' + \omega_0^2 y = \frac{F_0}{m} \cos \omega_0 t. \quad (6.1.22)$$

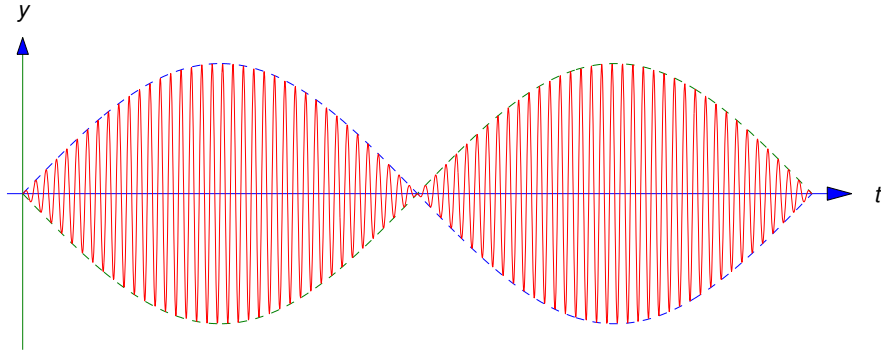

Figure 6.1.6 Undamped oscillation with beats

**Solution** We first obtain a particular solution  $y_p$  of (6.1.22). Since  $\cos \omega_0 t$  is a solution of the complementary equation, the form for  $y_p$  is

$$y_p = t(A \cos \omega_0 t + B \sin \omega_0 t). \quad (6.1.23)$$

Then

$$y_p' = A \cos \omega_0 t + B \sin \omega_0 t + \omega_0 t(-A \sin \omega_0 t + B \cos \omega_0 t)$$

and

$$y_p'' = 2\omega_0(-A \sin \omega_0 t + B \cos \omega_0 t) - \omega_0^2 t(A \cos \omega_0 t + B \sin \omega_0 t). \quad (6.1.24)$$

From (6.1.23) and (6.1.24), we see that  $y_p$  satisfies (6.1.22) if

$$-2A\omega_0 \sin \omega_0 t + 2B\omega_0 \cos \omega_0 t = \frac{F_0}{m} \cos \omega_0 t;$$

that is, if

$$A = 0 \quad \text{and} \quad B = \frac{F_0}{2m\omega_0}.$$

Therefore

$$y_p = \frac{F_0 t}{2m\omega_0} \sin \omega_0 t$$

is a particular solution of (6.1.22). The general solution of (6.1.22) is

$$y = \frac{F_0 t}{2m\omega_0} \sin \omega_0 t + c_1 \cos \omega_0 t + c_2 \sin \omega_0 t.$$

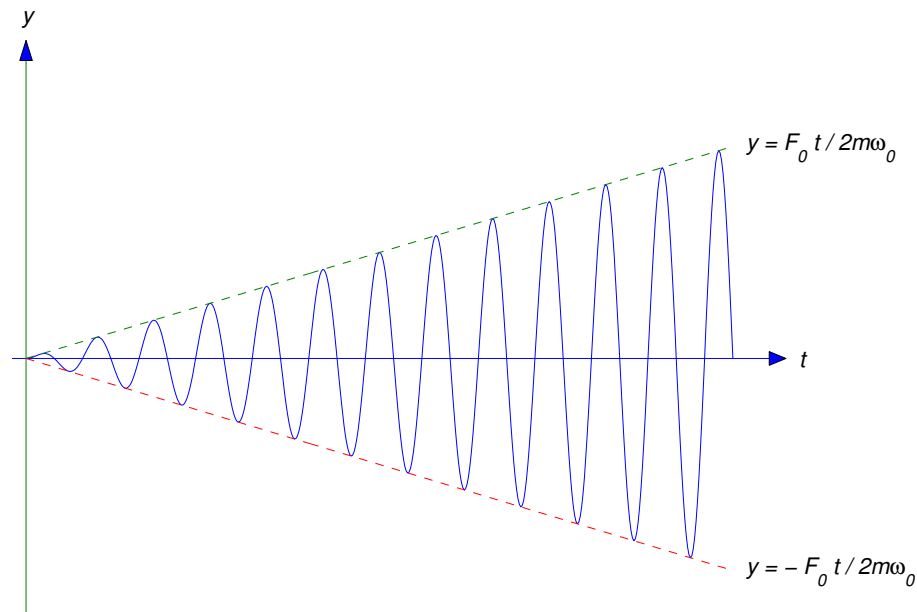

Figure 6.1.7 Unbounded displacement due to resonance

The graph of  $y_p$  is shown in Figure 6.1.7, where it can be seen that  $y_p$  oscillates between the dashed lines

$$y = \frac{F_0 t}{2m\omega_0} \quad \text{and} \quad y = -\frac{F_0 t}{2m\omega_0}$$

with increasing amplitude that approaches  $\infty$  as  $t \rightarrow \infty$ . Of course, this means that the spring must eventually fail to obey Hooke's law or break. ■

This phenomenon of unbounded displacements of a spring–mass system in response to a periodic forcing function at its natural frequency is called *resonance*. More complicated mechanical structures can also exhibit resonance–like phenomena. For example, rhythmic oscillations of a suspension bridge by wind forces or of an airplane wing by periodic vibrations of reciprocating engines can cause damage or even failure if the frequencies of the disturbances are close to critical frequencies determined by the parameters of the mechanical system in question.

### 6.1 Exercises

In the following exercises assume that there's no damping.

1. **C/G** An object stretches a spring 4 inches in equilibrium. Find and graph its displacement for  $t > 0$  if it's initially displaced 36 inches above equilibrium and given a downward velocity of 2 ft/s.
2. An object stretches a string 1.2 inches in equilibrium. Find its displacement for  $t > 0$  if it's initially displaced 3 inches below equilibrium and given a downward velocity of 2 ft/s.
3. A spring with natural length .5 m has length 50.5 cm with a mass of 2 gm suspended from it. The mass is initially displaced 1.5 cm below equilibrium and released with zero velocity. Find its displacement for  $t > 0$ .

4. An object stretches a spring 6 inches in equilibrium. Find its displacement for  $t > 0$  if it's initially displaced 3 inches above equilibrium and given a downward velocity of 6 inches/s. Find the frequency, period, amplitude and phase angle of the motion.
5. **C/G** An object stretches a spring 5 cm in equilibrium. It is initially displaced 10 cm above equilibrium and given an upward velocity of .25 m/s. Find and graph its displacement for  $t > 0$ . Find the frequency, period, amplitude, and phase angle of the motion.
6. A 10 kg mass stretches a spring 70 cm in equilibrium. Suppose a 2 kg mass is attached to the spring, initially displaced 25 cm below equilibrium, and given an upward velocity of 2 m/s. Find its displacement for  $t > 0$ . Find the frequency, period, amplitude, and phase angle of the motion.
7. A weight stretches a spring 1.5 inches in equilibrium. The weight is initially displaced 8 inches above equilibrium and given a downward velocity of 4 ft/s. Find its displacement for  $t > 0$ .
8. A weight stretches a spring 6 inches in equilibrium. The weight is initially displaced 6 inches above equilibrium and given a downward velocity of 3 ft/s. Find its displacement for  $t > 0$ .
9. A spring–mass system has natural frequency  $7\sqrt{10}$  rad/s. The natural length of the spring is .7 m. What is the length of the spring when the mass is in equilibrium?
10. A 64 lb weight is attached to a spring with constant  $k = 8$  lb/ft and subjected to an external force  $F(t) = 2 \sin t$ . The weight is initially displaced 6 inches above equilibrium and given an upward velocity of 2 ft/s. Find its displacement for  $t > 0$ .
11. A unit mass hangs in equilibrium from a spring with constant  $k = 1/16$ . Starting at  $t = 0$ , a force  $F(t) = 3 \sin t$  is applied to the mass. Find its displacement for  $t > 0$ .
12. **C/G** A 4 lb weight stretches a spring 1 ft in equilibrium. An external force  $F(t) = .25 \sin 8t$  lb is applied to the weight, which is initially displaced 4 inches above equilibrium and given a downward velocity of 1 ft/s. Find and graph its displacement for  $t > 0$ .
13. A 2 lb weight stretches a spring 6 inches in equilibrium. An external force  $F(t) = \sin 8t$  lb is applied to the weight, which is released from rest 2 inches below equilibrium. Find its displacement for  $t > 0$ .
14. A 10 gm mass suspended on a spring moves in simple harmonic motion with period 4 s. Find the period of the simple harmonic motion of a 20 gm mass suspended from the same spring.
15. A 6 lb weight stretches a spring 6 inches in equilibrium. Suppose an external force  $F(t) = \frac{3}{16} \sin \omega t + \frac{3}{8} \cos \omega t$  lb is applied to the weight. For what value of  $\omega$  will the displacement be unbounded? Find the displacement if  $\omega$  has this value. Assume that the motion starts from equilibrium with zero initial velocity.
16. **C/G** A 6 lb weight stretches a spring 4 inches in equilibrium. Suppose an external force  $F(t) = 4 \sin \omega t - 6 \cos \omega t$  lb is applied to the weight. For what value of  $\omega$  will the displacement be unbounded? Find and graph the displacement if  $\omega$  has this value. Assume that the motion starts from equilibrium with zero initial velocity.
17. A mass of one kg is attached to a spring with constant  $k = 4$  N/m. An external force  $F(t) = -\cos \omega t - 2 \sin \omega t$  n is applied to the mass. Find the displacement  $y$  for  $t > 0$  if  $\omega$  equals the natural frequency of the spring–mass system. Assume that the mass is initially displaced 3 m above equilibrium and given an upward velocity of 450 cm/s.
18. An object is in simple harmonic motion with frequency  $\omega_0$ , with  $y(0) = y_0$  and  $y'(0) = v_0$ . Find its displacement for  $t > 0$ . Also, find the amplitude of the oscillation and give formulas for the sine and cosine of the initial phase angle.

19. Two objects suspended from identical springs are set into motion. The period of one object is twice the period of the other. How are the weights of the two objects related?
20. Two objects suspended from identical springs are set into motion. The weight of one object is twice the weight of the other. How are the periods of the resulting motions related?
21. Two identical objects suspended from different springs are set into motion. The period of one motion is 3 times the period of the other. How are the two spring constants related?

## 6.2 SPRING PROBLEMS II

### Free Vibrations With Damping

In this section we consider the motion of an object in a spring–mass system with damping. We start with unforced motion, so the equation of motion is

$$my'' + cy' + ky = 0. \quad (6.2.1)$$

Now suppose the object is displaced from equilibrium and given an initial velocity. Intuition suggests that if the damping force is sufficiently weak the resulting motion will be oscillatory, as in the undamped case considered in the previous section, while if it's sufficiently strong the object may just move slowly toward the equilibrium position without ever reaching it. We'll now confirm these intuitive ideas mathematically. The characteristic equation of (6.2.1) is

$$mr^2 + cr + k = 0.$$

The roots of this equation are

$$r_1 = \frac{-c - \sqrt{c^2 - 4mk}}{2m} \quad \text{and} \quad r_2 = \frac{-c + \sqrt{c^2 - 4mk}}{2m}. \quad (6.2.2)$$

In Section 5.2 we saw that the form of the solution of (6.2.1) depends upon whether  $c^2 - 4mk$  is positive, negative, or zero. We'll now consider these three cases.

#### Underdamped Motion

We say the motion is *underdamped* if  $c < \sqrt{4mk}$ . In this case  $r_1$  and  $r_2$  in (6.2.2) are complex conjugates, which we write as

$$r_1 = -\frac{c}{2m} - i\omega_1 \quad \text{and} \quad r_2 = -\frac{c}{2m} + i\omega_1,$$

where

$$\omega_1 = \frac{\sqrt{4mk - c^2}}{2m}.$$

The general solution of (6.2.1) in this case is

$$y = e^{-ct/2m}(c_1 \cos \omega_1 t + c_2 \sin \omega_1 t).$$

By the method used in Section 6.1 to derive the amplitude–phase form of the displacement of an object in simple harmonic motion, we can rewrite this equation as

$$y = Re^{-ct/2m} \cos(\omega_1 t - \phi), \quad (6.2.3)$$

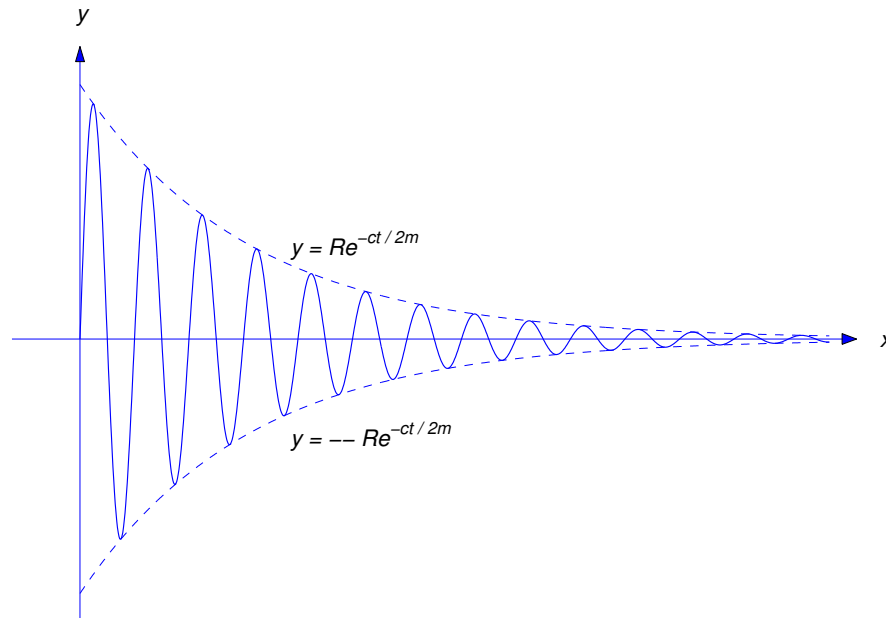

Figure 6.2.1 Underdamped motion

where

$$R = \sqrt{c_1^2 + c_2^2}, \quad R \cos \phi = c_1, \quad \text{and} \quad R \sin \phi = c_2.$$

The factor  $Re^{-ct/2m}$  in (6.2.3) is called the *time-varying amplitude* of the motion, the quantity  $\omega_1$  is called the *frequency*, and  $T = 2\pi/\omega_1$  (which is the period of the cosine function in (6.2.3)) is called the *quasi-period*. A typical graph of (6.2.3) is shown in Figure 6.2.1. As illustrated in that figure, the graph of  $y$  oscillates between the dashed exponential curves  $y = \pm Re^{-ct/2m}$ .

**Overdamped Motion**

We say the motion is *overdamped* if  $c > \sqrt{4mk}$ . In this case the zeros  $r_1$  and  $r_2$  of the characteristic polynomial are real, with  $r_1 < r_2 < 0$  (see (6.2.2)), and the general solution of (6.2.1) is

$$y = c_1 e^{r_1 t} + c_2 e^{r_2 t}.$$

Again  $\lim_{t \rightarrow \infty} y(t) = 0$  as in the underdamped case, but the motion isn't oscillatory, since  $y$  can't equal zero for more than one value of  $t$  unless  $c_1 = c_2 = 0$ . (Exercise 23.)

**Critically Damped Motion**

We say the motion is *critically damped* if  $c = \sqrt{4mk}$ . In this case  $r_1 = r_2 = -c/2m$  and the general solution of (6.2.1) is

$$y = e^{-ct/2m}(c_1 + c_2 t).$$

Again  $\lim_{t \rightarrow \infty} y(t) = 0$  and the motion is nonoscillatory, since  $y$  can't equal zero for more than one value of  $t$  unless  $c_1 = c_2 = 0$ . (Exercise 22).

**Example 6.2.1** Suppose a 64 lb weight stretches a spring 6 inches in equilibrium and a dashpot provides a damping force of  $c$  lb for each ft/sec of velocity.

- Write the equation of motion of the object and determine the value of  $c$  for which the motion is critically damped.
- Find the displacement  $y$  for  $t > 0$  if the motion is critically damped and the initial conditions are  $y(0) = 1$  and  $y'(0) = 20$ .
- Find the displacement  $y$  for  $t > 0$  if the motion is critically damped and the initial conditions are  $y(0) = 1$  and  $y'(0) = -20$ .

**SOLUTION(a)** Here  $m = 2$  slugs and  $k = 64/.5 = 128$  lb/ft. Therefore the equation of motion (6.2.1) is

$$2y'' + cy' + 128y = 0. \quad (6.2.4)$$

The characteristic equation is

$$2r^2 + cr + 128 = 0,$$

which has roots

$$r = \frac{-c \pm \sqrt{c^2 - 8 \cdot 128}}{4}.$$

Therefore the damping is critical if

$$c = \sqrt{8 \cdot 128} = 32 \text{ lb-sec/ft.}$$

**SOLUTION(b)** Setting  $c = 32$  in (6.2.4) and cancelling the common factor 2 yields

$$y'' + 16y' + 64y = 0.$$

The characteristic equation is

$$r^2 + 16r + 64y = (r + 8)^2 = 0.$$

Hence, the general solution is

$$y = e^{-8t}(c_1 + c_2 t). \quad (6.2.5)$$

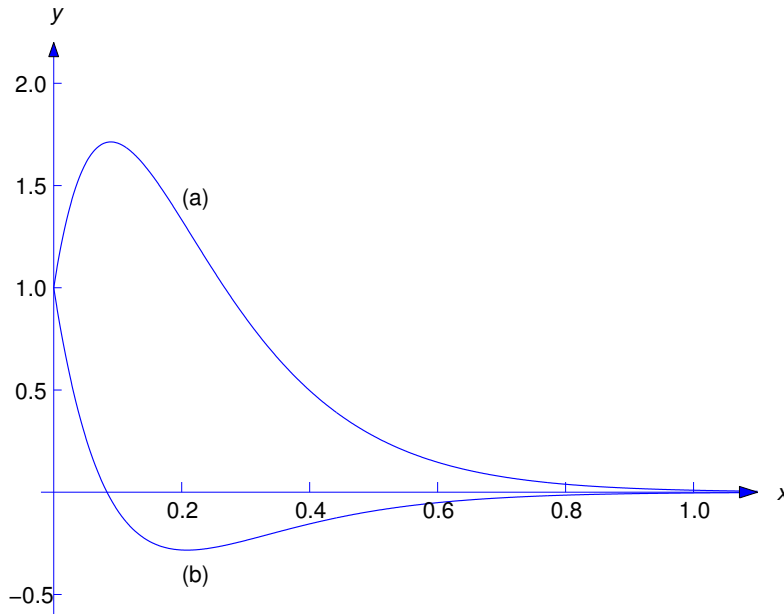

Figure 6.2.2 (a)  $y = e^{-8t}(1 + 28t)$  (b)  $y = e^{-8t}(1 - 12t)$

Differentiating this yields

$$y' = -8y + c_2 e^{-8t}. \quad (6.2.6)$$

Imposing the initial conditions  $y(0) = 1$  and  $y'(0) = 20$  in the last two equations shows that  $1 = c_1$  and  $20 = -8 + c_2$ . Hence, the solution of the initial value problem is

$$y = e^{-8t}(1 + 28t).$$

Therefore the object approaches equilibrium from above as  $t \rightarrow \infty$ . There's no oscillation.

**SOLUTION(c)** Imposing the initial conditions  $y(0) = 1$  and  $y'(0) = -20$  in (6.2.5) and (6.2.6) yields  $1 = c_1$  and  $-20 = -8 + c_2$ . Hence, the solution of this initial value problem is

$$y = e^{-8t}(1 - 12t).$$

Therefore the object moves downward through equilibrium just once, and then approaches equilibrium from below as  $t \rightarrow \infty$ . Again, there's no oscillation. The solutions of these two initial value problems are graphed in Figure 6.2.2.

**Example 6.2.2** Find the displacement of the object in Example 6.2.1 if the damping constant is  $c = 4$  lb-sec/ft and the initial conditions are  $y(0) = 1.5$  ft and  $y'(0) = -3$  ft/sec.

**Solution** With  $c = 4$ , the equation of motion (6.2.4) becomes

$$y'' + 2y' + 64y = 0 \quad (6.2.7)$$

after cancelling the common factor 2. The characteristic equation

$$r^2 + 2r + 64 = 0$$



has complex conjugate roots

$$r = \frac{-2 \pm \sqrt{4 - 4 \cdot 64}}{2} = -1 \pm 3\sqrt{7}i.$$

Therefore the motion is underdamped and the general solution of (6.2.7) is

$$y = e^{-t}(c_1 \cos 3\sqrt{7}t + c_2 \sin 3\sqrt{7}t).$$

Differentiating this yields

$$y' = -y + 3\sqrt{7}e^{-t}(-c_1 \sin 3\sqrt{7}t + c_2 \cos 3\sqrt{7}t).$$

Imposing the initial conditions  $y(0) = 1.5$  and  $y'(0) = -3$  in the last two equations yields  $1.5 = c_1$  and  $-3 = -1.5 + 3\sqrt{7}c_2$ . Hence, the solution of the initial value problem is

$$y = e^{-t} \left( \frac{3}{2} \cos 3\sqrt{7}t - \frac{1}{2\sqrt{7}} \sin 3\sqrt{7}t \right). \quad (6.2.8)$$

The amplitude of the function in parentheses is

$$R = \sqrt{\left(\frac{3}{2}\right)^2 + \left(\frac{1}{2\sqrt{7}}\right)^2} = \sqrt{\frac{9}{4} + \frac{1}{4 \cdot 7}} = \sqrt{\frac{64}{4 \cdot 7}} = \frac{4}{\sqrt{7}}.$$

Therefore we can rewrite (6.2.8) as

$$y = \frac{4}{\sqrt{7}} e^{-t} \cos(3\sqrt{7}t - \phi),$$

where

$$\cos \phi = \frac{3}{2R} = \frac{3\sqrt{7}}{8} \quad \text{and} \quad \sin \phi = -\frac{1}{2\sqrt{7}R} = -\frac{1}{8}.$$

Therefore  $\phi \cong -.125$  radians.

**Example 6.2.3** Let the damping constant in Example 1 be  $c = 40$  lb-sec/ft. Find the displacement  $y$  for  $t > 0$  if  $y(0) = 1$  and  $y'(0) = 1$ .

**Solution** With  $c = 40$ , the equation of motion (6.2.4) reduces to

$$y'' + 20y' + 64y = 0 \quad (6.2.9)$$

after cancelling the common factor 2. The characteristic equation

$$r^2 + 20r + 64 = (r + 16)(r + 4) = 0$$

has the roots  $r_1 = -4$  and  $r_2 = -16$ . Therefore the general solution of (6.2.9) is

$$y = c_1 e^{-4t} + c_2 e^{-16t}. \quad (6.2.10)$$

Differentiating this yields

$$y' = -4c_1 e^{-4t} - 16c_2 e^{-16t}.$$

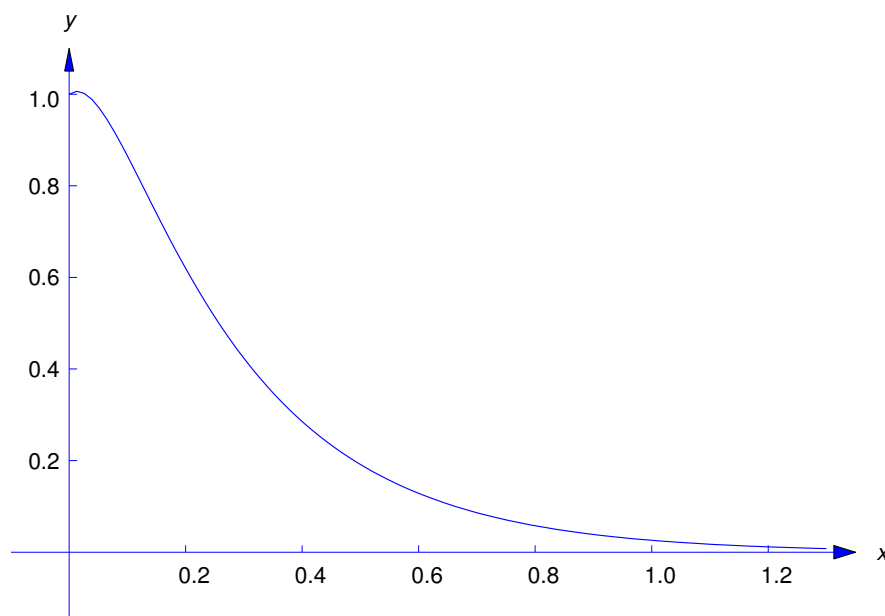

Figure 6.2.3  $y = \frac{17}{12}e^{-4t} - \frac{5}{12}e^{-16t}$

The last two equations and the initial conditions  $y(0) = 1$  and  $y'(0) = 1$  imply that

$$\begin{aligned} c_1 + c_2 &= 1 \\ -4c_1 - 16c_2 &= 1. \end{aligned}$$

The solution of this system is  $c_1 = 17/12$ ,  $c_2 = -5/12$ . Substituting these into (6.2.10) yields

$$y = \frac{17}{12}e^{-4t} - \frac{5}{12}e^{-16t}$$

as the solution of the given initial value problem (Figure 6.2.3).

### Forced Vibrations With Damping

Now we consider the motion of an object in a spring-mass system with damping, under the influence of a periodic forcing function  $F(t) = F_0 \cos \omega t$ , so that the equation of motion is

$$my'' + cy' + ky = F_0 \cos \omega t. \quad (6.2.11)$$

In Section 6.1 we considered this equation with  $c = 0$  and found that the resulting displacement  $y$  assumed arbitrarily large values in the case of resonance (that is, when  $\omega = \omega_0 = \sqrt{k/m}$ ). Here we'll see that in the presence of damping the displacement remains bounded for all  $t$ , and the initial conditions have little effect on the motion as  $t \rightarrow \infty$ . In fact, we'll see that for large  $t$  the displacement is closely approximated by a function of the form

$$y = R \cos(\omega t - \phi), \quad (6.2.12)$$

where the amplitude  $R$  depends upon  $m$ ,  $c$ ,  $k$ ,  $F_0$ , and  $\omega$ . We're interested in the following question:

QUESTION: Assuming that  $m$ ,  $c$ ,  $k$ , and  $F_0$  are held constant, what value of  $\omega$  produces the largest amplitude  $R$  in (6.2.12), and what is this largest amplitude?

To answer this question, we must solve (6.2.11) and determine  $R$  in terms of  $F_0, \omega_0, \omega$ , and  $c$ . We can obtain a particular solution of (6.2.11) by the method of undetermined coefficients. Since  $\cos \omega t$  does not satisfy the complementary equation

$$my'' + cy' + ky = 0,$$

we can obtain a particular solution of (6.2.11) in the form

$$y_p = A \cos \omega t + B \sin \omega t. \quad (6.2.13)$$

Differentiating this yields

$$y'_p = \omega(-A \sin \omega t + B \cos \omega t)$$

and

$$y''_p = -\omega^2(A \cos \omega t + B \sin \omega t).$$

From the last three equations,

$$my''_p + cy'_p + ky_p = (-m\omega^2 A + c\omega B + kA) \cos \omega t + (-m\omega^2 B - c\omega A + kB) \sin \omega t,$$

so  $y_p$  satisfies (6.2.11) if

$$\begin{aligned} (k - m\omega^2)A + c\omega B &= F_0 \\ -c\omega A + (k - m\omega^2)B &= 0. \end{aligned}$$

Solving for  $A$  and  $B$  and substituting the results into (6.2.13) yields

$$y_p = \frac{F_0}{(k - m\omega^2)^2 + c^2\omega^2} [(k - m\omega^2) \cos \omega t + c\omega \sin \omega t],$$

which can be written in amplitude–phase form as

$$y_p = \frac{F_0}{\sqrt{(k - m\omega^2)^2 + c^2\omega^2}} \cos(\omega t - \phi), \quad (6.2.14)$$

where

$$\cos \phi = \frac{k - m\omega^2}{\sqrt{(k - m\omega^2)^2 + c^2\omega^2}} \quad \text{and} \quad \sin \phi = \frac{c\omega}{\sqrt{(k - m\omega^2)^2 + c^2\omega^2}}. \quad (6.2.15)$$

To compare this with the undamped forced vibration that we considered in Section 6.1 it's useful to write

$$k - m\omega^2 = m \left( \frac{k}{m} - \omega^2 \right) = m(\omega_0^2 - \omega^2), \quad (6.2.16)$$

where  $\omega_0 = \sqrt{k/m}$  is the natural angular frequency of the undamped simple harmonic motion of an object with mass  $m$  on a spring with constant  $k$ . Substituting (6.2.16) into (6.2.14) yields

$$y_p = \frac{F_0}{\sqrt{m^2(\omega_0^2 - \omega^2)^2 + c^2\omega^2}} \cos(\omega t - \phi). \quad (6.2.17)$$

The solution of an initial value problem

$$my'' + cy' + ky = F_0 \cos \omega t, \quad y(0) = y_0, \quad y'(0) = v_0,$$

is of the form  $y = y_c + y_p$ , where  $y_c$  has one of the three forms

$$\begin{aligned}y_c &= e^{-ct/2m}(c_1 \cos \omega_1 t + c_2 \sin \omega_1 t), \\y_c &= e^{-ct/2m}(c_1 + c_2 t), \\y_c &= c_1 e^{r_1 t} + c_2 e^{r_2 t} \quad (r_1, r_2 < 0).\end{aligned}$$

In all three cases  $\lim_{t \rightarrow \infty} y_c(t) = 0$  for any choice of  $c_1$  and  $c_2$ . For this reason we say that  $y_c$  is the *transient component* of the solution  $y$ . The behavior of  $y$  for large  $t$  is determined by  $y_p$ , which we call the *steady state component* of  $y$ . Thus, for large  $t$  the motion is like simple harmonic motion at the frequency of the external force.

The amplitude of  $y_p$  in (6.2.17) is

$$R = \frac{F_0}{\sqrt{m^2(\omega_0^2 - \omega^2)^2 + c^2\omega^2}}, \quad (6.2.18)$$

which is finite for all  $\omega$ ; that is, the presence of damping precludes the phenomenon of resonance that we encountered in studying undamped vibrations under a periodic forcing function. We'll now find the value  $\omega_{\max}$  of  $\omega$  for which  $R$  is maximized. This is the value of  $\omega$  for which the function

$$\rho(\omega) = m^2(\omega_0^2 - \omega^2)^2 + c^2\omega^2$$

in the denominator of (6.2.18) attains its minimum value. By rewriting this as

$$\rho(\omega) = m^2(\omega_0^4 + \omega^4) + (c^2 - 2m^2\omega_0^2)\omega^2, \quad (6.2.19)$$

you can see that  $\rho$  is a strictly increasing function of  $\omega^2$  if

$$c \geq \sqrt{2m^2\omega_0^2} = \sqrt{2mk}.$$

(Recall that  $\omega_0^2 = k/m$ .) Therefore  $\omega_{\max} = 0$  if this inequality holds. From (6.2.15), you can see that  $\phi = 0$  if  $\omega = 0$ . In this case, (6.2.14) reduces to

$$y_p = \frac{F_0}{\sqrt{m^2\omega_0^4}} = \frac{F_0}{k},$$

which is consistent with Hooke's law: if the mass is subjected to a constant force  $F_0$ , its displacement should approach a constant  $y_p$  such that  $ky_p = F_0$ . Now suppose  $c < \sqrt{2mk}$ . Then, from (6.2.19),

$$\rho'(\omega) = 2\omega(2m^2\omega^2 + c^2 - 2m^2\omega_0^2),$$

and  $\omega_{\max}$  is the value of  $\omega$  for which the expression in parentheses equals zero; that is,

$$\omega_{\max} = \sqrt{\omega_0^2 - \frac{c^2}{2m^2}} = \sqrt{\frac{k}{m} \left(1 - \frac{c^2}{2km}\right)}.$$

(To see that  $\rho(\omega_{\max})$  is the minimum value of  $\rho(\omega)$ , note that  $\rho'(\omega) < 0$  if  $\omega < \omega_{\max}$  and  $\rho'(\omega) > 0$  if  $\omega > \omega_{\max}$ .) Substituting  $\omega = \omega_{\max}$  in (6.2.18) and simplifying shows that the maximum amplitude  $R_{\max}$  is

$$R_{\max} = \frac{2mF_0}{c\sqrt{4mk - c^2}} \quad \text{if } c < \sqrt{2mk}.$$

We summarize our results as follows.

**Theorem 6.2.1** Suppose we consider the amplitude  $R$  of the steady state component of the solution of

$$my'' + cy' + ky = F_0 \cos \omega t$$

as a function of  $\omega$ .

- (a) If  $c \geq \sqrt{2mk}$ , the maximum amplitude is  $R_{\max} = F_0/k$  and it's attained when  $\omega = \omega_{\max} = 0$ .  
 (b) If  $c < \sqrt{2mk}$ , the maximum amplitude is

$$R_{\max} = \frac{2mF_0}{c\sqrt{4mk - c^2}}, \quad (6.2.20)$$

and it's attained when

$$\omega = \omega_{\max} = \sqrt{\frac{k}{m} \left(1 - \frac{c^2}{2km}\right)}. \quad (6.2.21)$$

Note that  $R_{\max}$  and  $\omega_{\max}$  are continuous functions of  $c$ , for  $c \geq 0$ , since (6.2.20) and (6.2.21) reduce to  $R_{\max} = F_0/k$  and  $\omega_{\max} = 0$  if  $c = \sqrt{2km}$ .

## 6.2 Exercises

---

1. A 64 lb object stretches a spring 4 ft in equilibrium. It is attached to a dashpot with damping constant  $c = 8$  lb-sec/ft. The object is initially displaced 18 inches above equilibrium and given a downward velocity of 4 ft/sec. Find its displacement and time-varying amplitude for  $t > 0$ .
2. C/G A 16 lb weight is attached to a spring with natural length 5 ft. With the weight attached, the spring measures 8.2 ft. The weight is initially displaced 3 ft below equilibrium and given an upward velocity of 2 ft/sec. Find and graph its displacement for  $t > 0$  if the medium resists the motion with a force of one lb for each ft/sec of velocity. Also, find its time-varying amplitude.
3. C/G An 8 lb weight stretches a spring 1.5 inches. It is attached to a dashpot with damping constant  $c=8$  lb-sec/ft. The weight is initially displaced 3 inches above equilibrium and given an upward velocity of 6 ft/sec. Find and graph its displacement for  $t > 0$ .
4. A 96 lb weight stretches a spring 3.2 ft in equilibrium. It is attached to a dashpot with damping constant  $c=18$  lb-sec/ft. The weight is initially displaced 15 inches below equilibrium and given a downward velocity of 12 ft/sec. Find its displacement for  $t > 0$ .
5. A 16 lb weight stretches a spring 6 inches in equilibrium. It is attached to a damping mechanism with constant  $c$ . Find all values of  $c$  such that the free vibration of the weight has infinitely many oscillations.
6. An 8 lb weight stretches a spring .32 ft. The weight is initially displaced 6 inches above equilibrium and given an upward velocity of 4 ft/sec. Find its displacement for  $t > 0$  if the medium exerts a damping force of 1.5 lb for each ft/sec of velocity.
7. A 32 lb weight stretches a spring 2 ft in equilibrium. It is attached to a dashpot with constant  $c = 8$  lb-sec/ft. The weight is initially displaced 8 inches below equilibrium and released from rest. Find its displacement for  $t > 0$ .
8. A mass of 20 gm stretches a spring 5 cm. The spring is attached to a dashpot with damping constant 400 dyne sec/cm. Determine the displacement for  $t > 0$  if the mass is initially displaced 9 cm above equilibrium and released from rest.
9. A 64 lb weight is suspended from a spring with constant  $k = 25$  lb/ft. It is initially displaced 18 inches above equilibrium and released from rest. Find its displacement for  $t > 0$  if the medium resists the motion with 6 lb of force for each ft/sec of velocity.
10. A 32 lb weight stretches a spring 1 ft in equilibrium. The weight is initially displaced 6 inches above equilibrium and given a downward velocity of 3 ft/sec. Find its displacement for  $t > 0$  if the medium resists the motion with a force equal to 3 times the speed in ft/sec.
11. An 8 lb weight stretches a spring 2 inches. It is attached to a dashpot with damping constant  $c=4$  lb-sec/ft. The weight is initially displaced 3 inches above equilibrium and given a downward velocity of 4 ft/sec. Find its displacement for  $t > 0$ .
12. C/G A 2 lb weight stretches a spring .32 ft. The weight is initially displaced 4 inches below equilibrium and given an upward velocity of 5 ft/sec. The medium provides damping with constant  $c = 1/8$  lb-sec/ft. Find and graph the displacement for  $t > 0$ .
13. An 8 lb weight stretches a spring 8 inches in equilibrium. It is attached to a dashpot with damping constant  $c = .5$  lb-sec/ft and subjected to an external force  $F(t) = 4 \cos 2t$  lb. Determine the steady state component of the displacement for  $t > 0$ .

14. A 32 lb weight stretches a spring 1 ft in equilibrium. It is attached to a dashpot with constant  $c = 12$  lb-sec/ft. The weight is initially displaced 8 inches above equilibrium and released from rest. Find its displacement for  $t > 0$ .
15. A mass of one kg stretches a spring 49 cm in equilibrium. A dashpot attached to the spring supplies a damping force of 4 N for each m/sec of speed. The mass is initially displaced 10 cm above equilibrium and given a downward velocity of 1 m/sec. Find its displacement for  $t > 0$ .
16. A mass of 100 grams stretches a spring 98 cm in equilibrium. A dashpot attached to the spring supplies a damping force of 600 dynes for each cm/sec of speed. The mass is initially displaced 10 cm above equilibrium and given a downward velocity of 1 m/sec. Find its displacement for  $t > 0$ .
17. A 192 lb weight is suspended from a spring with constant  $k = 6$  lb/ft and subjected to an external force  $F(t) = 8 \cos 3t$  lb. Find the steady state component of the displacement for  $t > 0$  if the medium resists the motion with a force equal to 8 times the speed in ft/sec.
18. A 2 gm mass is attached to a spring with constant 20 dyne/cm. Find the steady state component of the displacement if the mass is subjected to an external force  $F(t) = 3 \cos 4t - 5 \sin 4t$  dynes and a dashpot supplies 4 dynes of damping for each cm/sec of velocity.
19. **C/G** A 96 lb weight is attached to a spring with constant 12 lb/ft. Find and graph the steady state component of the displacement if the mass is subjected to an external force  $F(t) = 18 \cos t - 9 \sin t$  lb and a dashpot supplies 24 lb of damping for each ft/sec of velocity.
20. A mass of one kg stretches a spring 49 cm in equilibrium. It is attached to a dashpot that supplies a damping force of 4 N for each m/sec of speed. Find the steady state component of its displacement if it's subjected to an external force  $F(t) = 8 \sin 2t - 6 \cos 2t$  N.
21. A mass  $m$  is suspended from a spring with constant  $k$  and subjected to an external force  $F(t) = \alpha \cos \omega_0 t + \beta \sin \omega_0 t$ , where  $\omega_0$  is the natural frequency of the spring-mass system without damping. Find the steady state component of the displacement if a dashpot with constant  $c$  supplies damping.
22. Show that if  $c_1$  and  $c_2$  are not both zero then

$$y = e^{r_1 t}(c_1 + c_2 t)$$

can't equal zero for more than one value of  $t$ .

23. Show that if  $c_1$  and  $c_2$  are not both zero then

$$y = c_1 e^{r_1 t} + c_2 e^{r_2 t}$$

can't equal zero for more than one value of  $t$ .

24. Find the solution of the initial value problem

$$my'' + cy' + ky = 0, \quad y(0) = y_0, \quad y'(0) = v_0,$$

given that the motion is underdamped, so the general solution of the equation is

$$y = e^{-ct/2m}(c_1 \cos \omega_1 t + c_2 \sin \omega_1 t).$$

25. Find the solution of the initial value problem

$$my'' + cy' + ky = 0, \quad y(0) = y_0, \quad y'(0) = v_0,$$

given that the motion is overdamped, so the general solution of the equation is

$$y = c_1 e^{r_1 t} + c_2 e^{r_2 t} \quad (r_1, r_2 < 0).$$

26. Find the solution of the initial value problem

$$my'' + cy' + ky = 0, \quad y(0) = y_0, \quad y'(0) = v_0,$$

given that the motion is critically damped, so that the general solution of the equation is of the form

$$y = e^{r_1 t}(c_1 + c_2 t) \quad (r_1 < 0).$$

### 6.3 THE RLC CIRCUIT

In this section we consider the *RLC circuit*, shown schematically in Figure 6.3.1. As we'll see, the *RLC* circuit is an electrical analog of a spring-mass system with damping.

Nothing happens while the switch is open (dashed line). When the switch is closed (solid line) we say that the *circuit is closed*. Differences in electrical potential in a closed circuit cause current to flow in the circuit. The battery or generator in Figure 6.3.1 creates a difference in electrical potential  $E = E(t)$  between its two terminals, which we've marked arbitrarily as positive and negative. (We could just as well interchange the markings.) We'll say that  $E(t) > 0$  if the potential at the positive terminal is greater than the potential at the negative terminal,  $E(t) < 0$  if the potential at the positive terminal is less than the potential at the negative terminal, and  $E(t) = 0$  if the potential is the same at the two terminals. We call  $E$  the *impressed voltage*.

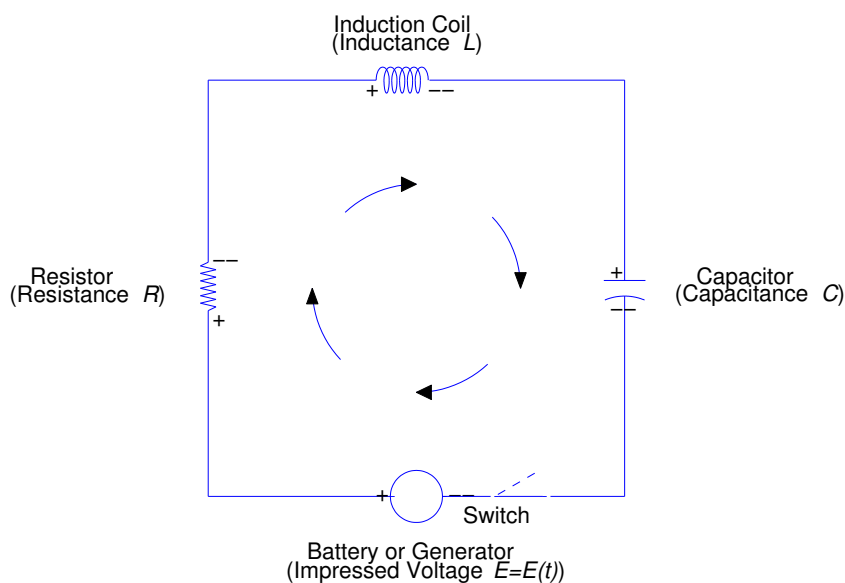

Figure 6.3.1 An *RLC* circuit

At any time  $t$ , the same current flows in all points of the circuit. We denote current by  $I = I(t)$ . We say that  $I(t) > 0$  if the direction of flow is around the circuit from the positive terminal of the battery or generator back to the negative terminal, as indicated by the arrows in Figure 6.3.1  $I(t) < 0$  if the flow is in the opposite direction, and  $I(t) = 0$  if no current flows at time  $t$ .



Differences in potential occur at the resistor, induction coil, and capacitor in Figure 6.3.1. Note that the two sides of each of these components are also identified as positive and negative. The *voltage drop across* each component is defined to be the potential on the positive side of the component minus the potential on the negative side. This terminology is somewhat misleading, since “drop” suggests a decrease even though changes in potential are signed quantities and therefore may be increases. Nevertheless, we’ll go along with tradition and call them voltage drops. The voltage drop across the resistor in Figure 6.3.1 is given by

$$V_R = IR, \quad (6.3.1)$$

where  $I$  is current and  $R$  is a positive constant, the *resistance* of the resistor. The voltage drop across the induction coil is given by

$$V_I = L \frac{dI}{dt} = LI', \quad (6.3.2)$$

where  $L$  is a positive constant, the *inductance* of the coil.

A capacitor stores electrical charge  $Q = Q(t)$ , which is related to the current in the circuit by the equation

$$Q(t) = Q_0 + \int_0^t I(\tau) d\tau, \quad (6.3.3)$$

where  $Q_0$  is the charge on the capacitor at  $t = 0$ . The voltage drop across a capacitor is given by

$$V_C = \frac{Q}{C}, \quad (6.3.4)$$

where  $C$  is a positive constant, the *capacitance* of the capacitor.

Table 6.3.8 names the units for the quantities that we’ve discussed. The units are defined so that

$$\begin{aligned} 1 \text{ volt} &= 1 \text{ ampere} \cdot 1 \text{ ohm} \\ &= 1 \text{ henry} \cdot 1 \text{ ampere/second} \\ &= 1 \text{ coulomb/farad} \end{aligned}$$

and

$$1 \text{ ampere} = 1 \text{ coulomb/second.}$$

Table 6.3.8. Electrical Units

Symbol	Name	Unit
$E$	Impressed Voltage	volt
$I$	Current	ampere
$Q$	Charge	coulomb
$R$	Resistance	ohm
$L$	Inductance	henry
$C$	Capacitance	farad

According to *Kirchoff’s law*, the sum of the voltage drops in a closed  $RLC$  circuit equals the impressed voltage. Therefore, from (6.3.1), (6.3.2), and (6.3.4),

$$LI' + RI + \frac{1}{C}Q = E(t). \quad (6.3.5)$$

This equation contains two unknowns, the current  $I$  in the circuit and the charge  $Q$  on the capacitor. However, (6.3.3) implies that  $Q' = I$ , so (6.3.5) can be converted into the second order equation

$$LQ'' + RQ' + \frac{1}{C}Q = E(t) \quad (6.3.6)$$

in  $Q$ . To find the current flowing in an  $RLC$  circuit, we solve (6.3.6) for  $Q$  and then differentiate the solution to obtain  $I$ .

In Sections 6.1 and 6.2 we encountered the equation

$$my'' + cy' + ky = F(t) \quad (6.3.7)$$

in connection with spring-mass systems. Except for notation this equation is the same as (6.3.6). The correspondence between electrical and mechanical quantities connected with (6.3.6) and (6.3.7) is shown in Table 6.3.9.

Table 6.3.9. Electrical and Mechanical Units

Electrical		Mechanical	
charge	$Q$	displacement	$y$
current	$I$	velocity	$y'$
impressed voltage	$E(t)$	external force	$F(t)$
inductance	$L$	Mass	$m$
resistance	$R$	damping	$c$
1/capacitance	$1/C$	spring constant	$k$

The equivalence between (6.3.6) and (6.3.7) is an example of how mathematics unifies fundamental similarities in diverse physical phenomena. Since we've already studied the properties of solutions of (6.3.7) in Sections 6.1 and 6.2, we can obtain results concerning solutions of (6.3.6) by simply changing notation, according to Table 6.3.8.

### Free Oscillations

We say that an  $RLC$  circuit is in *free oscillation* if  $E(t) = 0$  for  $t > 0$ , so that (6.3.6) becomes

$$LQ'' + RQ' + \frac{1}{C}Q = 0. \quad (6.3.8)$$

The characteristic equation of (6.3.8) is

$$Lr^2 + Rr + \frac{1}{C} = 0,$$

with roots

$$r_1 = \frac{-R - \sqrt{R^2 - 4L/C}}{2L} \quad \text{and} \quad r_2 = \frac{-R + \sqrt{R^2 - 4L/C}}{2L}. \quad (6.3.9)$$

There are three cases to consider, all analogous to the cases considered in Section 6.2 for free vibrations of a damped spring-mass system.

CASE 1. The oscillation is *underdamped* if  $R < \sqrt{4L/C}$ . In this case,  $r_1$  and  $r_2$  in (6.3.9) are complex conjugates, which we write as

$$r_1 = -\frac{R}{2L} + i\omega_1 \quad \text{and} \quad r_2 = -\frac{R}{2L} - i\omega_1,$$

where

$$\omega_1 = \frac{\sqrt{4L/C - R^2}}{2L}.$$

The general solution of (6.3.8) is

$$Q = e^{-Rt/2L}(c_1 \cos \omega_1 t + c_2 \sin \omega_1 t),$$

which we can write as

$$Q = Ae^{-Rt/2L} \cos(\omega_1 t - \phi), \quad (6.3.10)$$

where

$$A = \sqrt{c_1^2 + c_2^2}, \quad A \cos \phi = c_1, \quad \text{and} \quad A \sin \phi = c_2.$$

In the idealized case where  $R = 0$ , the solution (6.3.10) reduces to

$$Q = A \cos\left(\frac{t}{\sqrt{LC}} - \phi\right),$$

which is analogous to the simple harmonic motion of an undamped spring-mass system in free vibration.

Actual RLC circuits are usually underdamped, so the case we've just considered is the most important. However, for completeness we'll consider the other two possibilities.

CASE 2. The oscillation is *overdamped* if  $R > \sqrt{4L/C}$ . In this case, the zeros  $r_1$  and  $r_2$  of the characteristic polynomial are real, with  $r_1 < r_2 < 0$  (see (6.3.9)), and the general solution of (6.3.8) is

$$Q = c_1 e^{r_1 t} + c_2 e^{r_2 t}. \quad (6.3.11)$$

CASE 3. The oscillation is *critically damped* if  $R = \sqrt{4L/C}$ . In this case,  $r_1 = r_2 = -R/2L$  and the general solution of (6.3.8) is

$$Q = e^{-Rt/2L}(c_1 + c_2 t). \quad (6.3.12)$$

If  $R \neq 0$ , the exponentials in (6.3.10), (6.3.11), and (6.3.12) are negative, so the solution of any homogeneous initial value problem

$$LQ'' + RQ' + \frac{1}{C}Q = 0, \quad Q(0) = Q_0, \quad Q'(0) = I_0,$$

approaches zero exponentially as  $t \rightarrow \infty$ . Thus, all such solutions are *transient*, in the sense defined Section 6.2 in the discussion of forced vibrations of a spring-mass system with damping.

**Example 6.3.1** At  $t = 0$  a current of 2 amperes flows in an RLC circuit with resistance  $R = 40$  ohms, inductance  $L = .2$  henrys, and capacitance  $C = 10^{-5}$  farads. Find the current flowing in the circuit at  $t > 0$  if the initial charge on the capacitor is 1 coulomb. Assume that  $E(t) = 0$  for  $t > 0$ .

**Solution** The equation for the charge  $Q$  is

$$\frac{1}{5}Q'' + 40Q' + 10000Q = 0,$$

or

$$Q'' + 200Q' + 50000Q = 0. \quad (6.3.13)$$

Therefore we must solve the initial value problem

$$Q'' + 200Q' + 50000Q = 0, \quad Q(0) = 1, \quad Q'(0) = 2. \quad (6.3.14)$$

The desired current is the derivative of the solution of this initial value problem.

The characteristic equation of (6.3.13) is

$$r^2 + 200r + 50000 = 0,$$

which has complex zeros  $r = -100 \pm 200i$ . Therefore the general solution of (6.3.13) is

$$Q = e^{-100t}(c_1 \cos 200t + c_2 \sin 200t). \quad (6.3.15)$$

Differentiating this and collecting like terms yields

$$Q' = -e^{-100t}[(100c_1 - 200c_2) \cos 200t + (100c_2 + 200c_1) \sin 200t]. \quad (6.3.16)$$

To find the solution of the initial value problem (6.3.14), we set  $t = 0$  in (6.3.15) and (6.3.16) to obtain

$$c_1 = Q(0) = 1 \quad \text{and} \quad -100c_1 + 200c_2 = Q'(0) = 2;$$

therefore,  $c_1 = 1$  and  $c_2 = 51/100$ , so

$$Q = e^{-100t} \left( \cos 200t + \frac{51}{100} \sin 200t \right)$$

is the solution of (6.3.14). Differentiating this yields

$$I = e^{-100t}(2 \cos 200t - 251 \sin 200t).$$

### Forced Oscillations With Damping

An initial value problem for (6.3.6) has the form

$$LQ'' + RQ' + \frac{1}{C}Q = E(t), \quad Q(0) = Q_0, \quad Q'(0) = I_0, \quad (6.3.17)$$

where  $Q_0$  is the initial charge on the capacitor and  $I_0$  is the initial current in the circuit. We've already seen that if  $E \equiv 0$  then all solutions of (6.3.17) are transient. If  $E \neq 0$ , we know that the solution of (6.3.17) has the form  $Q = Q_c + Q_p$ , where  $Q_c$  satisfies the complementary equation, and approaches zero exponentially as  $t \rightarrow \infty$  for any initial conditions, while  $Q_p$  depends only on  $E$  and is independent of the initial conditions. As in the case of forced oscillations of a spring-mass system with damping, we call  $Q_p$  the *steady state* charge on the capacitor of the *RLC* circuit. Since  $I = Q' = Q'_c + Q'_p$  and  $Q'_c$  also tends to zero exponentially as  $t \rightarrow \infty$ , we say that  $I_c = Q'_c$  is the *transient* current and  $I_p = Q'_p$  is the *steady state* current. In most applications we're interested only in the steady state charge and current.

**Example 6.3.2** Find the amplitude-phase form of the steady state current in the *RLC* circuit in Figure 6.3.1 if the impressed voltage, provided by an alternating current generator, is  $E(t) = E_0 \cos \omega t$ .

**Solution** We'll first find the steady state charge on the capacitor as a particular solution of

$$LQ'' + RQ' + \frac{1}{C}Q = E_0 \cos \omega t.$$

To do, this we'll simply reinterpret a result obtained in Section 6.2, where we found that the steady state solution of

$$my'' + cy' + ky = F_0 \cos \omega t$$

is

$$y_p = \frac{F_0}{\sqrt{(k - m\omega^2)^2 + c^2\omega^2}} \cos(\omega t - \phi),$$

where

$$\cos \phi = \frac{k - m\omega^2}{\sqrt{(k - m\omega^2)^2 + c^2\omega^2}} \quad \text{and} \quad \sin \phi = \frac{c\omega}{\sqrt{(k - m\omega^2)^2 + c^2\omega^2}}.$$

(See Equations (6.2.14) and (6.2.15).) By making the appropriate changes in the symbols (according to Table 2) yields the steady state charge

$$Q_p = \frac{E_0}{\sqrt{(1/C - L\omega^2)^2 + R^2\omega^2}} \cos(\omega t - \phi),$$

where

$$\cos \phi = \frac{1/C - L\omega^2}{\sqrt{(1/C - L\omega^2)^2 + R^2\omega^2}} \quad \text{and} \quad \sin \phi = \frac{R\omega}{\sqrt{(1/C - L\omega^2)^2 + R^2\omega^2}}.$$

Therefore the steady state current in the circuit is

$$I_p = Q'_p = -\frac{\omega E_0}{\sqrt{(1/C - L\omega^2)^2 + R^2\omega^2}} \sin(\omega t - \phi).$$

### 6.3 Exercises

In Exercises 1-5 find the current in the RLC circuit, assuming that  $E(t) = 0$  for  $t > 0$ .

1.  $R = 3$  ohms;  $L = .1$  henrys;  $C = .01$  farads;  $Q_0 = 0$  coulombs;  $I_0 = 2$  amperes.
2.  $R = 2$  ohms;  $L = .05$  henrys;  $C = .01$  farads;  $Q_0 = 2$  coulombs;  $I_0 = -2$  amperes.
3.  $R = 2$  ohms;  $L = .1$  henrys;  $C = .01$  farads;  $Q_0 = 2$  coulombs;  $I_0 = 0$  amperes.
4.  $R = 6$  ohms;  $L = .1$  henrys;  $C = .004$  farads;  $Q_0 = 3$  coulombs;  $I_0 = -10$  amperes.
5.  $R = 4$  ohms;  $L = .05$  henrys;  $C = .008$  farads;  $Q_0 = -1$  coulombs;  $I_0 = 2$  amperes.

In Exercises 6-10 find the steady state current in the circuit described by the equation.

6.  $\frac{1}{10}Q'' + 3Q' + 100Q = 5 \cos 10t - 5 \sin 10t$
7.  $\frac{1}{20}Q'' + 2Q' + 100Q = 10 \cos 25t - 5 \sin 25t$
8.  $\frac{1}{10}Q'' + 2Q' + 100Q = 3 \cos 50t - 6 \sin 50t$
9.  $\frac{1}{10}Q'' + 6Q' + 250Q = 10 \cos 100t + 30 \sin 100t$
10.  $\frac{1}{20}Q'' + 4Q' + 125Q = 15 \cos 30t - 30 \sin 30t$
11. Show that if  $E(t) = U \cos \omega t + V \sin \omega t$  where  $U$  and  $V$  are constants then the steady state current in the RLC circuit shown in Figure 6.3.1 is

$$I_p = \frac{\omega^2 RE(t) + (1/C - L\omega^2)E'(t)}{\Delta},$$

where

$$\Delta = (1/C - L\omega^2)^2 + R^2\omega^2.$$

12. Find the amplitude of the steady state current  $I_p$  in the  $RLC$  circuit shown in Figure 6.3.1 if  $E(t) = U \cos \omega t + V \sin \omega t$ , where  $U$  and  $V$  are constants. Then find the value  $\omega_0$  of  $\omega$  maximizes the amplitude, and find the maximum amplitude.

In Exercises 13-17 plot the amplitude of the steady state current against  $\omega$ . Estimate the value of  $\omega$  that maximizes the amplitude of the steady state current, and estimate this maximum amplitude. HINT: You can confirm your results by doing Exercise 12.

13.  $\boxed{\text{L}}$   $\frac{1}{10}Q'' + 3Q' + 100Q = U \cos \omega t + V \sin \omega t$

14.  $\boxed{\text{L}}$   $\frac{1}{20}Q'' + 2Q' + 100Q = U \cos \omega t + V \sin \omega t$

15.  $\boxed{\text{L}}$   $\frac{1}{10}Q'' + 2Q' + 100Q = U \cos \omega t + V \sin \omega t$

16.  $\boxed{\text{L}}$   $\frac{1}{10}Q'' + 6Q' + 250Q = U \cos \omega t + V \sin \omega t$

17.  $\boxed{\text{L}}$   $\frac{1}{20}Q'' + 4Q' + 125Q = U \cos \omega t + V \sin \omega t$

#### 6.4 MOTION UNDER A CENTRAL FORCE

We'll now study the motion of a object moving under the influence of a *central force*; that is, a force whose magnitude at any point  $P$  other than the origin depends only on the distance from  $P$  to the origin, and whose direction at  $P$  is parallel to the line connecting  $P$  and the origin, as indicated in Figure 6.4.1 for the case where the direction of the force at every point is toward the origin. Gravitational forces are central forces; for example, as mentioned in Section 4.3, if we assume that Earth is a perfect sphere with constant mass density then Newton's law of gravitation asserts that the force exerted on an object by Earth's gravitational field is proportional to the mass of the object and inversely proportional to the square of its distance from the center of Earth, which we take to be the origin.

If the initial position and velocity vectors of an object moving under a central force are parallel, then the subsequent motion is along the line from the origin to the initial position. Here we'll assume that the initial position and velocity vectors are not parallel; in this case the subsequent motion is in the plane determined by them. For convenience we take this to be the  $xy$ -plane. We'll consider the problem of determining the curve traversed by the object. We call this curve the *orbit*.

We can represent a central force in terms of polar coordinates

$$x = r \cos \theta, \quad y = r \sin \theta$$

as

$$\mathbf{F}(r, \theta) = f(r)(\cos \theta \mathbf{i} + \sin \theta \mathbf{j}).$$

We assume that  $f$  is continuous for all  $r > 0$ . The magnitude of  $\mathbf{F}$  at  $(x, y) = (r \cos \theta, r \sin \theta)$  is  $|f(r)|$ , so it depends only on the distance  $r$  from the point to the origin the direction of  $\mathbf{F}$  is from the point to the origin if  $f(r) < 0$ , or from the origin to the point if  $f(r) > 0$ . We'll show that the orbit of an object with mass  $m$  moving under this force is given by

$$r(\theta) = \frac{1}{u(\theta)},$$

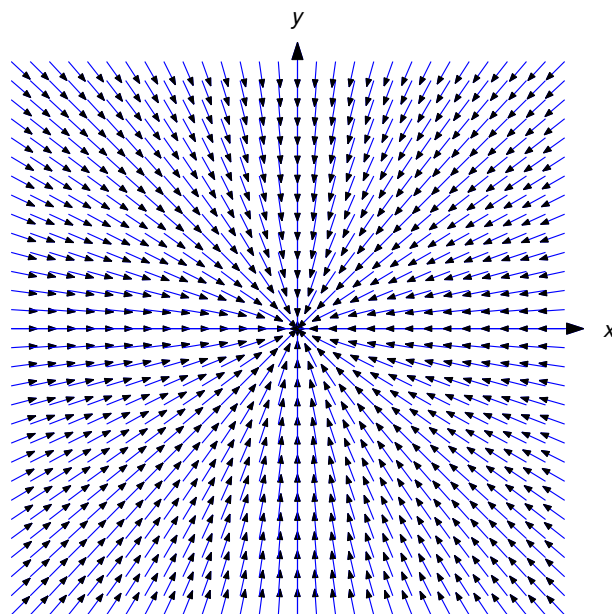

Figure 6.4.1

where  $u$  is solution of the differential equation

$$\frac{d^2u}{d\theta^2} + u = -\frac{1}{mh^2u^2}f(1/u), \quad (6.4.1)$$

and  $h$  is a constant defined below.

Newton's second law of motion ( $\mathbf{F} = m\mathbf{a}$ ) says that the polar coordinates  $r = r(t)$  and  $\theta = \theta(t)$  of the particle satisfy the vector differential equation

$$m(r \cos \theta \mathbf{i} + r \sin \theta \mathbf{j})'' = f(r)(\cos \theta \mathbf{i} + \sin \theta \mathbf{j}). \quad (6.4.2)$$

To deal with this equation we introduce the unit vectors

$$\mathbf{e}_1 = \cos \theta \mathbf{i} + \sin \theta \mathbf{j} \quad \text{and} \quad \mathbf{e}_2 = -\sin \theta \mathbf{i} + \cos \theta \mathbf{j}.$$

Note that  $\mathbf{e}_1$  points in the direction of increasing  $r$  and  $\mathbf{e}_2$  points in the direction of increasing  $\theta$  (Figure 6.4.2); moreover,

$$\frac{d\mathbf{e}_1}{d\theta} = \mathbf{e}_2, \quad \frac{d\mathbf{e}_2}{d\theta} = -\mathbf{e}_1, \quad (6.4.3)$$

and

$$\mathbf{e}_1 \cdot \mathbf{e}_2 = \cos \theta (-\sin \theta) + \sin \theta \cos \theta = 0,$$

so  $\mathbf{e}_1$  and  $\mathbf{e}_2$  are perpendicular. Recalling that the single prime ( $'$ ) stands for differentiation with respect to  $t$ , we see from (6.4.3) and the chain rule that

$$\mathbf{e}_1' = \theta' \mathbf{e}_2 \quad \text{and} \quad \mathbf{e}_2' = -\theta' \mathbf{e}_1. \quad (6.4.4)$$

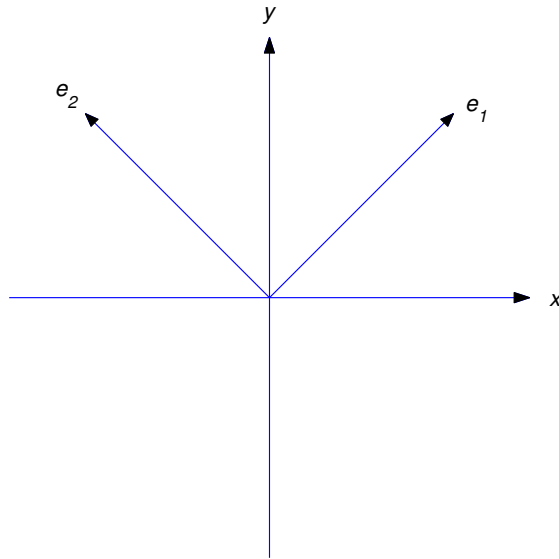

Figure 6.4.2

Now we can write (6.4.2) as

$$m(re_1)'' = f(r)e_1. \tag{6.4.5}$$

But

$$(re_1)' = r'e_1 + re_1' = r'e_1 + r\theta'e_2$$

(from (6.4.4)), and

$$\begin{aligned} (re_1)'' &= (r'e_1 + r\theta'e_2)' \\ &= r''e_1 + r'e_1' + (r\theta'' + r'\theta')e_2 + r\theta'e_2' \\ &= r''e_1 + r'\theta'e_2 + (r\theta'' + r'\theta')e_2 - r(\theta')^2e_1 \quad (\text{from (6.4.4)}) \\ &= (r'' - r(\theta')^2)e_1 + (r\theta'' + 2r'\theta')e_2. \end{aligned}$$

Substituting this into (6.4.5) yields

$$m(r'' - r(\theta')^2)e_1 + m(r\theta'' + 2r'\theta')e_2 = f(r)e_1.$$

By equating the coefficients of  $e_1$  and  $e_2$  on the two sides of this equation we see that

$$m(r'' - r(\theta')^2) = f(r) \tag{6.4.6}$$

and

$$r\theta'' + 2r'\theta' = 0.$$

Multiplying the last equation by  $r$  yields

$$r^2\theta'' + 2rr'\theta' = (r^2\theta')' = 0,$$



so

$$r^2\theta' = h, \quad (6.4.7)$$

where  $h$  is a constant that we can write in terms of the initial conditions as

$$h = r^2(0)\theta'(0).$$

Since the initial position and velocity vectors are

$$r(0)\mathbf{e}_1(0) \quad \text{and} \quad r'(0)\mathbf{e}_1(0) + r(0)\theta'(0)\mathbf{e}_2(0),$$

our assumption that these two vectors are not parallel implies that  $\theta'(0) \neq 0$ , so  $h \neq 0$ .

Now let  $u = 1/r$ . Then  $u^2 = \theta'/h$  (from (6.4.7)) and

$$r' = -\frac{u'}{u^2} = -h \left( \frac{u'}{\theta'} \right),$$

which implies that

$$r' = -h \frac{du}{d\theta}, \quad (6.4.8)$$

since

$$\frac{u'}{\theta'} = \frac{du}{dt} \bigg/ \frac{d\theta}{dt} = \frac{du}{d\theta}.$$

Differentiating (6.4.8) with respect to  $t$  yields

$$r'' = -h \frac{d}{dt} \left( \frac{du}{d\theta} \right) = -h \frac{d^2u}{d\theta^2} \theta',$$

which implies that

$$r'' = -h^2 u^2 \frac{d^2u}{d\theta^2} \quad \text{since} \quad \theta' = hu^2.$$

Substituting from these equalities into (6.4.6) and recalling that  $r = 1/u$  yields

$$-m \left( h^2 u^2 \frac{d^2u}{d\theta^2} + \frac{1}{u} h^2 u^4 \right) = f(1/u),$$

and dividing through by  $-mh^2u^2$  yields (6.4.1).

Eqn. (6.4.7) has the following geometrical interpretation, which is known as *Kepler's Second Law*.

**Theorem 6.4.1** *The position vector of an object moving under a central force sweeps out equal areas in equal times; more precisely, if  $\theta(t_1) \leq \theta(t_2)$  then the (signed) area of the sector*

$$\{(x, y) = (r \cos \theta, r \sin \theta) : 0 \leq r \leq r(\theta), \theta(t_1) \leq \theta(t_2)\}$$

(Figure 6.4.3) is given by

$$A = \frac{h(t_2 - t_1)}{2},$$

where  $h = r^2\theta'$ , which we have shown to be constant.

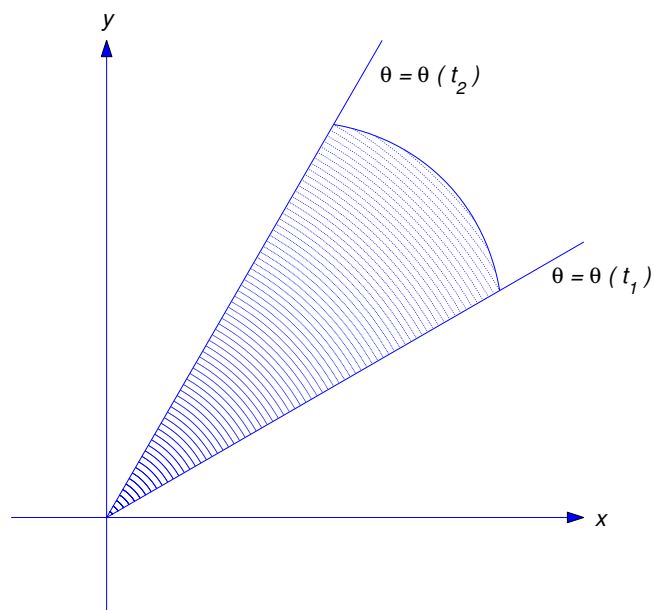

Figure 6.4.3

**Proof** Recall from calculus that the area of the shaded sector in Figure 6.4.3 is

$$A = \frac{1}{2} \int_{\theta(t_1)}^{\theta(t_2)} r^2(\theta) d\theta,$$

where  $r = r(\theta)$  is the polar representation of the orbit. Making the change of variable  $\theta = \theta(t)$  yields

$$A = \frac{1}{2} \int_{t_1}^{t_2} r^2(\theta(t)) \theta'(t) dt. \quad (6.4.9)$$

But (6.4.7) and (6.4.9) imply that

$$A = \frac{1}{2} \int_{t_1}^{t_2} h dt = \frac{h(t_2 - t_1)}{2},$$

which completes the proof.

#### Motion Under an Inverse Square Law Force

In the special case where  $f(r) = -mk/r^2 = -mku^2$ , so  $\mathbf{F}$  can be interpreted as a gravitational force, (6.4.1) becomes

$$\frac{d^2u}{d\theta^2} + u = \frac{k}{h^2}. \quad (6.4.10)$$

The general solution of the complementary equation

$$\frac{d^2u}{d\theta^2} + u = 0$$

can be written in amplitude–phase form as

$$u = A \cos(\theta - \phi),$$

where  $A \geq 0$  and  $\phi$  is a phase angle. Since  $u_p = k/h^2$  is a particular solution of (6.4.10), the general solution of (6.4.10) is

$$u = A \cos(\theta - \phi) + \frac{k}{h^2};$$

hence, the orbit is given by

$$r = \left( A \cos(\theta - \phi) + \frac{k}{h^2} \right)^{-1},$$

which we rewrite as

$$r = \frac{\rho}{1 + e \cos(\theta - \phi)}, \quad (6.4.11)$$

where

$$\rho = \frac{h^2}{k} \quad \text{and} \quad e = A\rho.$$

A curve satisfying (6.4.11) is a conic section with a focus at the origin (Exercise 1). The nonnegative constant  $e$  is the *eccentricity* of the orbit, which is an ellipse if  $e < 1$  (a circle if  $e = 0$ ), a parabola if  $e = 1$ , or a hyperbola if  $e > 1$ .

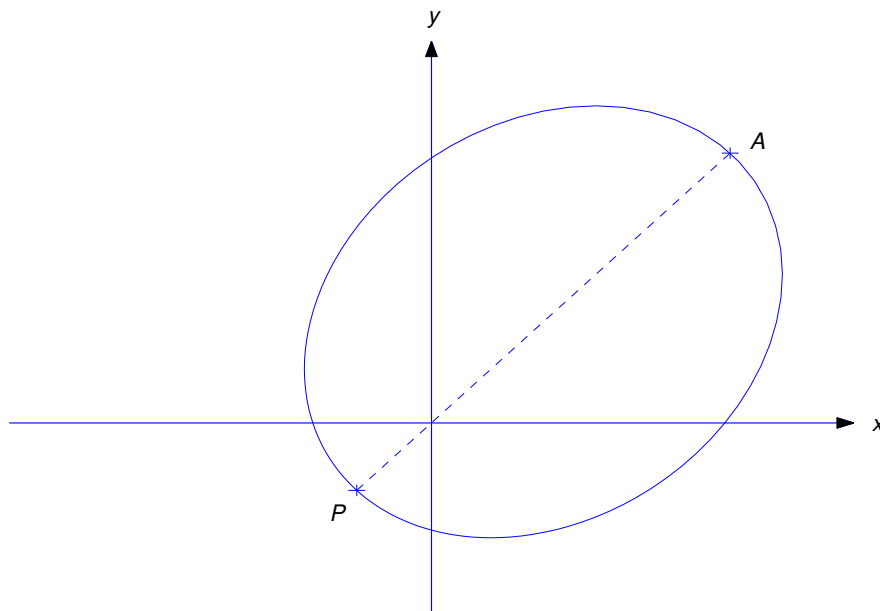

Figure 6.4.4

If the orbit is an ellipse, then the minimum and maximum values of  $r$  are

$$\begin{aligned} r_{\min} &= \frac{\rho}{1 + e} \quad (\text{the } \textit{perihelion distance}, \text{ attained when } \theta = \phi) \\ r_{\max} &= \frac{\rho}{1 - e} \quad (\text{the } \textit{aphelion distance}, \text{ attained when } \theta = \phi + \pi). \end{aligned}$$

Figure 6.4.4 shows a typical elliptic orbit. The point  $P$  on the orbit where  $r = r_{\min}$  is the *perigee* and the point  $A$  where  $r = r_{\max}$  is the *apogee*.

For example, Earth's orbit around the Sun is approximately an ellipse with  $e \approx .017$ ,  $r_{\min} \approx 91 \times 10^6$  miles, and  $r_{\max} \approx 95 \times 10^6$  miles. Halley's comet has a very elongated approximately elliptical orbit around the sun, with  $e \approx .967$ ,  $r_{\min} \approx 55 \times 10^6$  miles, and  $r_{\max} \approx 33 \times 10^8$  miles. Some comets (the nonrecurring type) have parabolic or hyperbolic orbits.

### 6.4 Exercises

1. Find the equation of the curve

$$r = \frac{\rho}{1 + e \cos(\theta - \phi)} \quad (\text{A})$$

in terms of  $(X, Y) = (r \cos(\theta - \phi), r \sin(\theta - \phi))$ , which are rectangular coordinates with respect to the axes shown in Figure 6.4.5. Use your results to verify that (A) is the equation of an ellipse if  $0 < e < 1$ , a parabola if  $e = 1$ , or a hyperbola if  $e > 1$ . If  $e < 1$ , leave your answer in the form

$$\frac{(X - X_0)^2}{a^2} + \frac{(Y - Y_0)^2}{b^2} = 1,$$

and show that the area of the ellipse is

$$A = \frac{\pi \rho^2}{(1 - e^2)^{3/2}}.$$

Then use Theorem 6.4.1 to show that the time required for the object to traverse the entire orbit is

$$T = \frac{2\pi \rho^2}{h(1 - e^2)^{3/2}}.$$

(This is *Kepler's third law*;  $T$  is called the *period* of the orbit.)

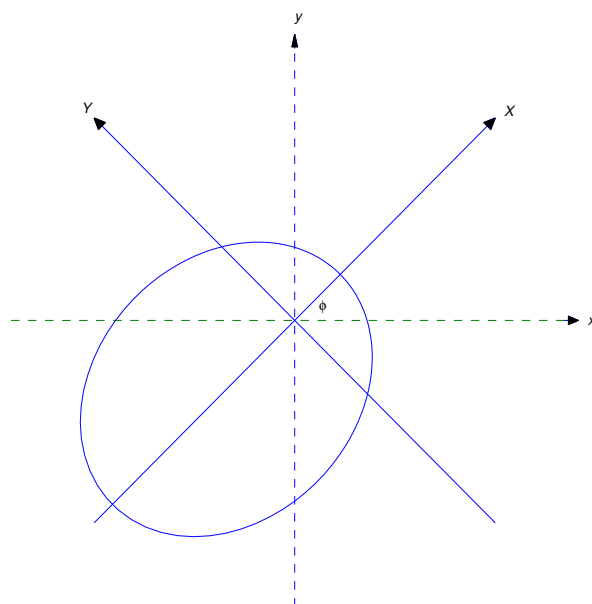

Figure 6.4.5

2. Suppose an object with mass  $m$  moves in the  $xy$ -plane under the central force

$$\mathbf{F}(r, \theta) = -\frac{mk}{r^2}(\cos \theta \mathbf{i} + \sin \theta \mathbf{j}),$$

where  $k$  is a positive constant. As we shown, the orbit of the object is given by

$$r = \frac{\rho}{1 + e \cos(\theta - \phi)}.$$

Determine  $\rho$ ,  $e$ , and  $\phi$  in terms of the initial conditions

$$r(0) = r_0, \quad r'(0) = r'_0, \quad \text{and} \quad \theta(0) = \theta_0, \quad \theta'(0) = \theta'_0.$$

Assume that the initial position and velocity vectors are not collinear.

3. Suppose we wish to put a satellite with mass  $m$  into an elliptical orbit around Earth. Assume that the only force acting on the object is Earth's gravity, given by

$$\mathbf{F}(r, \theta) = -mg \left( \frac{R^2}{r^2} \right) (\cos \theta \mathbf{i} + \sin \theta \mathbf{j}),$$

where  $R$  is Earth's radius,  $g$  is the acceleration due to gravity at Earth's surface, and  $r$  and  $\theta$  are polar coordinates in the plane of the orbit, with the origin at Earth's center.

- (a) Find the eccentricity required to make the aphelion and perihelion distances equal to  $R\gamma_1$  and  $R\gamma_2$ , respectively, where  $1 < \gamma_1 < \gamma_2$ .  
 (b) Find the initial conditions

$$r(0) = r_0, \quad r'(0) = r'_0, \quad \text{and} \quad \theta(0) = \theta_0, \quad \theta'(0) = \theta'_0$$

required to make the initial point the perigee, and the motion along the orbit in the direction of increasing  $\theta$ . HINT: Use the results of Exercise 2.

4. An object with mass  $m$  moves in a spiral orbit  $r = c\theta^2$  under a central force

$$\mathbf{F}(r, \theta) = f(r)(\cos \theta \mathbf{i} + \sin \theta \mathbf{j}).$$

Find  $f$ .

5. An object with mass  $m$  moves in the orbit  $r = r_0 e^{\gamma\theta}$  under a central force

$$\mathbf{F}(r, \theta) = f(r)(\cos \theta \mathbf{i} + \sin \theta \mathbf{j}).$$

Find  $f$ .

6. Suppose an object with mass  $m$  moves under the central force

$$\mathbf{F}(r, \theta) = -\frac{mk}{r^3}(\cos \theta \mathbf{i} + \sin \theta \mathbf{j}),$$

with

$$r(0) = r_0, \quad r'(0) = r'_0, \quad \text{and} \quad \theta(0) = \theta_0, \quad \theta'(0) = \theta'_0,$$

where  $h = r_0^2 \theta'_0 \neq 0$ .

- (a) Set up a second order initial value problem for  $u = 1/r$  as a function of  $\theta$ .  
 (b) Determine  $r = r(\theta)$  if (i)  $h^2 < k$ ; (ii)  $h^2 = k$ ; (iii)  $h^2 > k$ .



# CHAPTER 7

## Series Solutions of Linear Second Equations

IN THIS CHAPTER we study a class of second order differential equations that occur in many applications, but can't be solved in closed form in terms of elementary functions. Here are some examples:

(1) Bessel's equation

$$x^2y'' + xy' + (x^2 - \nu^2)y = 0,$$

which occurs in problems displaying cylindrical symmetry, such as diffraction of light through a circular aperture, propagation of electromagnetic radiation through a coaxial cable, and vibrations of a circular drum head.

(2) Airy's equation,

$$y'' - xy = 0,$$

which occurs in astronomy and quantum physics.

(3) Legendre's equation

$$(1 - x^2)y'' - 2xy' + \alpha(\alpha + 1)y = 0,$$

which occurs in problems displaying spherical symmetry, particularly in electromagnetism. These equations and others considered in this chapter can be written in the form

$$P_0(x)y'' + P_1(x)y' + P_2(x)y = 0, \tag{A}$$

where  $P_0$ ,  $P_1$ , and  $P_2$  are polynomials with no common factor. For most equations that occur in applications, these polynomials are of degree two or less. We'll impose this restriction, although the methods that we'll develop can be extended to the case where the coefficient functions are polynomials of arbitrary degree, or even power series that converge in some circle around the origin in the complex plane.

Since (A) does not in general have closed form solutions, we seek series representations for solutions. We'll see that if  $P_0(0) \neq 0$  then solutions of (A) can be written as power series

$$y = \sum_{n=0}^{\infty} a_n x^n$$

that converge in an open interval centered at  $x = 0$ .

SECTION 7.1 reviews the properties of power series.

SECTIONS 7.2 AND 7.3 are devoted to finding power series solutions of (A) in the case where  $P_0(0) \neq 0$ . The situation is more complicated if  $P_0(0) = 0$ ; however, if  $P_1$  and  $P_2$  satisfy assumptions that apply to most equations of interest, then we're able to use a modified series method to obtain solutions of (A).

SECTION 7.4 introduces the appropriate assumptions on  $P_1$  and  $P_2$  in the case where  $P_0(0) = 0$ , and deals with *Euler's equation*

$$ax^2y'' + bxy' + cy = 0,$$

where  $a$ ,  $b$ , and  $c$  are constants. This is the simplest equation that satisfies these assumptions.

SECTIONS 7.5 –7.7 deal with three distinct cases satisfying the assumptions introduced in Section 7.4. In all three cases, (A) has at least one solution of the form

$$y_1 = x^r \sum_{n=0}^{\infty} a_n x^n,$$

where  $r$  need not be an integer. The problem is that there are three possibilities – each requiring a different approach – for the form of a second solution  $y_2$  such that  $\{y_1, y_2\}$  is a fundamental pair of solutions of (A).



## 7.1 REVIEW OF POWER SERIES

Many applications give rise to differential equations with solutions that can't be expressed in terms of elementary functions such as polynomials, rational functions, exponential and logarithmic functions, and trigonometric functions. The solutions of some of the most important of these equations can be expressed in terms of power series. We'll study such equations in this chapter. In this section we review relevant properties of power series. We'll omit proofs, which can be found in any standard calculus text.

**Definition 7.1.1** An infinite series of the form

$$\sum_{n=0}^{\infty} a_n(x - x_0)^n, \quad (7.1.1)$$

where  $x_0$  and  $a_0, a_1, \dots, a_n, \dots$  are constants, is called a *power series in  $x - x_0$* . We say that the power series (7.1.1) *converges* for a given  $x$  if the limit

$$\lim_{N \rightarrow \infty} \sum_{n=0}^N a_n(x - x_0)^n$$

exists; otherwise, we say that the power series *diverges* for the given  $x$ .

A power series in  $x - x_0$  must converge if  $x = x_0$ , since the positive powers of  $x - x_0$  are all zero in this case. This may be the only value of  $x$  for which the power series converges. However, the next theorem shows that if the power series converges for some  $x \neq x_0$  then the set of all values of  $x$  for which it converges forms an interval.

**Theorem 7.1.2** For any power series

$$\sum_{n=0}^{\infty} a_n(x - x_0)^n,$$

exactly one of the these statements is true:

- (i) The power series converges only for  $x = x_0$ .
- (ii) The power series converges for all values of  $x$ .
- (iii) There's a positive number  $R$  such that the power series converges if  $|x - x_0| < R$  and diverges if  $|x - x_0| > R$ .

In case (iii) we say that  $R$  is the *radius of convergence* of the power series. For convenience, we include the other two cases in this definition by defining  $R = 0$  in case (i) and  $R = \infty$  in case (ii). We define the *open interval of convergence* of  $\sum_{n=0}^{\infty} a_n(x - x_0)^n$  to be

$$(x_0 - R, x_0 + R) \quad \text{if } 0 < R < \infty, \quad \text{or} \quad (-\infty, \infty) \quad \text{if } R = \infty.$$

If  $R$  is finite, no general statement can be made concerning convergence at the endpoints  $x = x_0 \pm R$  of the open interval of convergence; the series may converge at one or both points, or diverge at both.

Recall from calculus that a series of constants  $\sum_{n=0}^{\infty} \alpha_n$  is said to *converge absolutely* if the series of absolute values  $\sum_{n=0}^{\infty} |\alpha_n|$  converges. It can be shown that a power series  $\sum_{n=0}^{\infty} a_n(x - x_0)^n$  with a positive radius of convergence  $R$  converges absolutely in its open interval of convergence; that is, the series

$$\sum_{n=0}^{\infty} |a_n| |x - x_0|^n$$

of absolute values converges if  $|x - x_0| < R$ . However, if  $R < \infty$ , the series may fail to converge absolutely at an endpoint  $x_0 \pm R$ , even if it converges there.

The next theorem provides a useful method for determining the radius of convergence of a power series. It's derived in calculus by applying the ratio test to the corresponding series of absolute values. For related theorems see Exercises 2 and 4.

**Theorem 7.1.3** *Suppose there's an integer  $N$  such that  $a_n \neq 0$  if  $n \geq N$  and*

$$\lim_{n \rightarrow \infty} \left| \frac{a_{n+1}}{a_n} \right| = L,$$

where  $0 \leq L \leq \infty$ . Then the radius of convergence of  $\sum_{n=0}^{\infty} a_n(x - x_0)^n$  is  $R = 1/L$ , which should be interpreted to mean that  $R = 0$  if  $L = \infty$ , or  $R = \infty$  if  $L = 0$ .

**Example 7.1.1** Find the radius of convergence of the series:

$$\text{(a)} \quad \sum_{n=0}^{\infty} n!x^n \quad \text{(b)} \quad \sum_{n=10}^{\infty} (-1)^n \frac{x^n}{n!} \quad \text{(c)} \quad \sum_{n=0}^{\infty} 2^n n^2 (x - 1)^n.$$

**SOLUTION(a)** Here  $a_n = n!$ , so

$$\lim_{n \rightarrow \infty} \left| \frac{a_{n+1}}{a_n} \right| = \lim_{n \rightarrow \infty} \frac{(n+1)!}{n!} = \lim_{n \rightarrow \infty} (n+1) = \infty.$$

Hence,  $R = 0$ .

**SOLUTION(b)** Here  $a_n = (1)^n/n!$  for  $n \geq N = 10$ , so

$$\lim_{n \rightarrow \infty} \left| \frac{a_{n+1}}{a_n} \right| = \lim_{n \rightarrow \infty} \frac{n!}{(n+1)!} = \lim_{n \rightarrow \infty} \frac{1}{n+1} = 0.$$

Hence,  $R = \infty$ .

**SOLUTION(c)** Here  $a_n = 2^n n^2$ , so

$$\lim_{n \rightarrow \infty} \left| \frac{a_{n+1}}{a_n} \right| = \lim_{n \rightarrow \infty} \frac{2^{n+1}(n+1)^2}{2^n n^2} = 2 \lim_{n \rightarrow \infty} \left(1 + \frac{1}{n}\right)^2 = 2.$$

Hence,  $R = 1/2$ .

### Taylor Series

If a function  $f$  has derivatives of all orders at a point  $x = x_0$ , then the *Taylor series of  $f$  about  $x_0$*  is defined by

$$\sum_{n=0}^{\infty} \frac{f^{(n)}(x_0)}{n!} (x - x_0)^n.$$

In the special case where  $x_0 = 0$ , this series is also called the *Maclaurin series of  $f$* .

Taylor series for most of the common elementary functions converge to the functions on their open intervals of convergence. For example, you are probably familiar with the following Maclaurin series:

$$e^x = \sum_{n=0}^{\infty} \frac{x^n}{n!}, \quad -\infty < x < \infty, \quad (7.1.2)$$

$$\sin x = \sum_{n=0}^{\infty} (-1)^n \frac{x^{2n+1}}{(2n+1)!}, \quad -\infty < x < \infty, \quad (7.1.3)$$

$$\cos x = \sum_{n=0}^{\infty} (-1)^n \frac{x^{2n}}{(2n)!}, \quad -\infty < x < \infty, \quad (7.1.4)$$

$$\frac{1}{1-x} = \sum_{n=0}^{\infty} x^n, \quad -1 < x < 1. \quad (7.1.5)$$

### Differentiation of Power Series

A power series with a positive radius of convergence defines a function

$$f(x) = \sum_{n=0}^{\infty} a_n(x-x_0)^n$$

on its open interval of convergence. We say that the series *represents*  $f$  on the open interval of convergence. A function  $f$  represented by a power series may be a familiar elementary function as in (7.1.2)–(7.1.5); however, it often happens that  $f$  isn't a familiar function, so the series actually *defines*  $f$ .

The next theorem shows that a function represented by a power series has derivatives of all orders on the open interval of convergence of the power series, and provides power series representations of the derivatives.

#### Theorem 7.1.4 A power series

$$f(x) = \sum_{n=0}^{\infty} a_n(x-x_0)^n$$

with positive radius of convergence  $R$  has derivatives of all orders in its open interval of convergence, and successive derivatives can be obtained by repeatedly differentiating term by term; that is,

$$f'(x) = \sum_{n=1}^{\infty} n a_n(x-x_0)^{n-1}, \quad (7.1.6)$$

$$f''(x) = \sum_{n=2}^{\infty} n(n-1) a_n(x-x_0)^{n-2}, \quad (7.1.7)$$

⋮

$$f^{(k)}(x) = \sum_{n=k}^{\infty} n(n-1)\cdots(n-k+1) a_n(x-x_0)^{n-k}. \quad (7.1.8)$$

Moreover, all of these series have the same radius of convergence  $R$ .

**Example 7.1.2** Let  $f(x) = \sin x$ . From (7.1.3),

$$f(x) = \sum_{n=0}^{\infty} (-1)^n \frac{x^{2n+1}}{(2n+1)!}.$$

From (7.1.6),

$$f'(x) = \sum_{n=0}^{\infty} (-1)^n \frac{d}{dx} \left[ \frac{x^{2n+1}}{(2n+1)!} \right] = \sum_{n=0}^{\infty} (-1)^n \frac{x^{2n}}{(2n)!},$$

which is the series (7.1.4) for  $\cos x$ .

### Uniqueness of Power Series

The next theorem shows that if  $f$  is *defined* by a power series in  $x - x_0$  with a positive radius of convergence, then the power series is the Taylor series of  $f$  about  $x_0$ .

**Theorem 7.1.5** *If the power series*

$$f(x) = \sum_{n=0}^{\infty} a_n (x - x_0)^n$$

*has a positive radius of convergence, then*

$$a_n = \frac{f^{(n)}(x_0)}{n!}; \quad (7.1.9)$$

*that is,  $\sum_{n=0}^{\infty} a_n (x - x_0)^n$  is the Taylor series of  $f$  about  $x_0$ .*

This result can be obtained by setting  $x = x_0$  in (7.1.8), which yields

$$f^{(k)}(x_0) = k(k-1) \cdots 1 \cdot a_k = k! a_k.$$

This implies that

$$a_k = \frac{f^{(k)}(x_0)}{k!}.$$

Except for notation, this is the same as (7.1.9).

The next theorem lists two important properties of power series that follow from Theorem 7.1.5.

**Theorem 7.1.6**

(a) *If*

$$\sum_{n=0}^{\infty} a_n (x - x_0)^n = \sum_{n=0}^{\infty} b_n (x - x_0)^n$$

*for all  $x$  in an open interval that contains  $x_0$ , then  $a_n = b_n$  for  $n = 0, 1, 2, \dots$*

(b) *If*

$$\sum_{n=0}^{\infty} a_n (x - x_0)^n = 0$$

*for all  $x$  in an open interval that contains  $x_0$ , then  $a_n = 0$  for  $n = 0, 1, 2, \dots$*

To obtain **(a)** we observe that the two series represent the same function  $f$  on the open interval; hence, Theorem 7.1.5 implies that

$$a_n = b_n = \frac{f^{(n)}(x_0)}{n!}, \quad n = 0, 1, 2, \dots$$

**(b)** can be obtained from **(a)** by taking  $b_n = 0$  for  $n = 0, 1, 2, \dots$

### Taylor Polynomials

If  $f$  has  $N$  derivatives at a point  $x_0$ , we say that

$$T_N(x) = \sum_{n=0}^N \frac{f^{(n)}(x_0)}{n!} (x - x_0)^n$$

is the  $N$ -th Taylor polynomial of  $f$  about  $x_0$ . This definition and Theorem 7.1.5 imply that if

$$f(x) = \sum_{n=0}^{\infty} a_n (x - x_0)^n,$$

where the power series has a positive radius of convergence, then the Taylor polynomials of  $f$  about  $x_0$  are given by

$$T_N(x) = \sum_{n=0}^N a_n (x - x_0)^n.$$

In numerical applications, we use the Taylor polynomials to approximate  $f$  on subintervals of the open interval of convergence of the power series. For example, (7.1.2) implies that the Taylor polynomial  $T_N$  of  $f(x) = e^x$  is

$$T_N(x) = \sum_{n=0}^N \frac{x^n}{n!}.$$

The solid curve in Figure 7.1.1 is the graph of  $y = e^x$  on the interval  $[0, 5]$ . The dotted curves in Figure 7.1.1 are the graphs of the Taylor polynomials  $T_1, \dots, T_6$  of  $y = e^x$  about  $x_0 = 0$ . From this figure, we conclude that the accuracy of the approximation of  $y = e^x$  by its Taylor polynomial  $T_N$  improves as  $N$  increases.

### Shifting the Summation Index

In Definition 7.1.1 of a power series in  $x - x_0$ , the  $n$ -th term is a constant multiple of  $(x - x_0)^n$ . This isn't true in (7.1.6), (7.1.7), and (7.1.8), where the general terms are constant multiples of  $(x - x_0)^{n-1}$ ,  $(x - x_0)^{n-2}$ , and  $(x - x_0)^{n-k}$ , respectively. However, these series can all be rewritten so that their  $n$ -th terms are constant multiples of  $(x - x_0)^n$ . For example, letting  $n = k + 1$  in the series in (7.1.6) yields

$$f'(x) = \sum_{k=0}^{\infty} (k+1)a_{k+1}(x - x_0)^k, \quad (7.1.10)$$

where we start the new summation index  $k$  from zero so that the first term in (7.1.10) (obtained by setting  $k = 0$ ) is the same as the first term in (7.1.6) (obtained by setting  $n = 1$ ). However, the sum of a series is independent of the symbol used to denote the summation index, just as the value of a definite integral is independent of the symbol used to denote the variable of integration. Therefore we can replace  $k$  by  $n$  in (7.1.10) to obtain

$$f'(x) = \sum_{n=0}^{\infty} (n+1)a_{n+1}(x - x_0)^n, \quad (7.1.11)$$

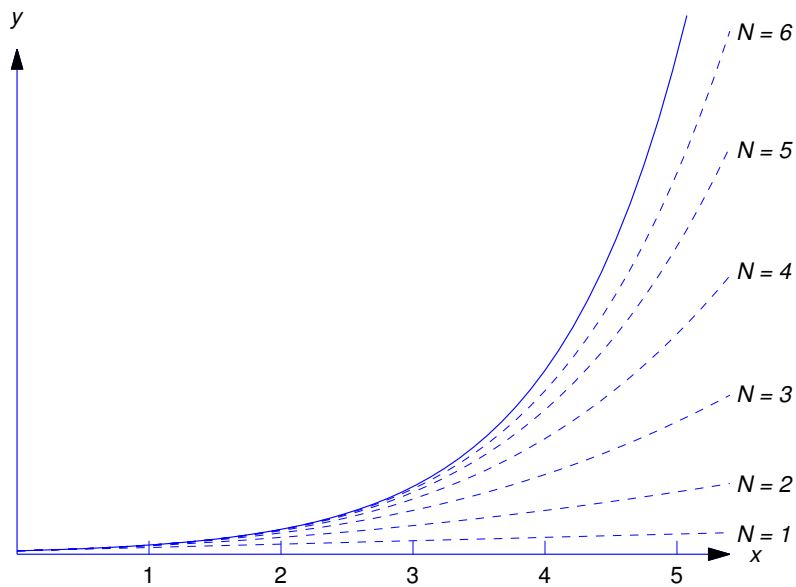

Figure 7.1.1 Approximation of  $y = e^x$  by Taylor polynomials about  $x = 0$

where the general term is a constant multiple of  $(x - x_0)^n$ .

It isn't really necessary to introduce the intermediate summation index  $k$ . We can obtain (7.1.11) directly from (7.1.6) by replacing  $n$  by  $n + 1$  in the general term of (7.1.6) and subtracting 1 from the lower limit of (7.1.6). More generally, we use the following procedure for shifting indices.

### Shifting the Summation Index in a Power Series

For any integer  $k$ , the power series

$$\sum_{n=n_0}^{\infty} b_n (x - x_0)^{n-k}$$

can be rewritten as

$$\sum_{n=n_0-k}^{\infty} b_{n+k} (x - x_0)^n;$$

that is, replacing  $n$  by  $n + k$  in the general term and subtracting  $k$  from the lower limit of summation leaves the series unchanged.

**Example 7.1.3** Rewrite the following power series from (7.1.7) and (7.1.8) so that the general term in

each is a constant multiple of  $(x - x_0)^n$ :

$$\text{(a)} \sum_{n=2}^{\infty} n(n-1)a_n(x-x_0)^{n-2} \quad \text{(b)} \sum_{n=k}^{\infty} n(n-1)\cdots(n-k+1)a_n(x-x_0)^{n-k}.$$

**SOLUTION(a)** Replacing  $n$  by  $n + 2$  in the general term and subtracting 2 from the lower limit of summation yields

$$\sum_{n=2}^{\infty} n(n-1)a_n(x-x_0)^{n-2} = \sum_{n=0}^{\infty} (n+2)(n+1)a_{n+2}(x-x_0)^n.$$

**SOLUTION(b)** Replacing  $n$  by  $n + k$  in the general term and subtracting  $k$  from the lower limit of summation yields

$$\sum_{n=k}^{\infty} n(n-1)\cdots(n-k+1)a_n(x-x_0)^{n-k} = \sum_{n=0}^{\infty} (n+k)(n+k-1)\cdots(n+1)a_{n+k}(x-x_0)^n.$$

**Example 7.1.4** Given that

$$f(x) = \sum_{n=0}^{\infty} a_n x^n,$$

write the function  $x f''$  as a power series in which the general term is a constant multiple of  $x^n$ .

**Solution** From Theorem 7.1.4 with  $x_0 = 0$ ,

$$f''(x) = \sum_{n=2}^{\infty} n(n-1)a_n x^{n-2}.$$

Therefore

$$x f''(x) = \sum_{n=2}^{\infty} n(n-1)a_n x^{n-1}.$$

Replacing  $n$  by  $n + 1$  in the general term and subtracting 1 from the lower limit of summation yields

$$x f''(x) = \sum_{n=1}^{\infty} (n+1)n a_{n+1} x^n.$$

We can also write this as

$$x f''(x) = \sum_{n=0}^{\infty} (n+1)n a_{n+1} x^n,$$

since the first term in this last series is zero. (We'll see later that sometimes it's useful to include zero terms at the beginning of a series.)

### Linear Combinations of Power Series

If a power series is multiplied by a constant, then the constant can be placed inside the summation; that is,

$$c \sum_{n=0}^{\infty} a_n (x - x_0)^n = \sum_{n=0}^{\infty} c a_n (x - x_0)^n.$$

Two power series

$$f(x) = \sum_{n=0}^{\infty} a_n(x-x_0)^n \quad \text{and} \quad g(x) = \sum_{n=0}^{\infty} b_n(x-x_0)^n$$

with positive radii of convergence can be added term by term at points common to their open intervals of convergence; thus, if the first series converges for  $|x-x_0| < R_1$  and the second converges for  $|x-x_0| < R_2$ , then

$$f(x) + g(x) = \sum_{n=0}^{\infty} (a_n + b_n)(x-x_0)^n$$

for  $|x-x_0| < R$ , where  $R$  is the smaller of  $R_1$  and  $R_2$ . More generally, linear combinations of power series can be formed term by term; for example,

$$c_1f(x) + c_2f(x) = \sum_{n=0}^{\infty} (c_1a_n + c_2b_n)(x-x_0)^n.$$

**Example 7.1.5** Find the Maclaurin series for  $\cosh x$  as a linear combination of the Maclaurin series for  $e^x$  and  $e^{-x}$ .

**Solution** By definition,

$$\cosh x = \frac{1}{2}e^x + \frac{1}{2}e^{-x}.$$

Since

$$e^x = \sum_{n=0}^{\infty} \frac{x^n}{n!} \quad \text{and} \quad e^{-x} = \sum_{n=0}^{\infty} (-1)^n \frac{x^n}{n!},$$

it follows that

$$\cosh x = \sum_{n=0}^{\infty} \frac{1}{2} [1 + (-1)^n] \frac{x^n}{n!}. \quad (7.1.12)$$

Since

$$\frac{1}{2} [1 + (-1)^n] = \begin{cases} 1 & \text{if } n = 2m, \text{ an even integer,} \\ 0 & \text{if } n = 2m + 1, \text{ an odd integer,} \end{cases}$$

we can rewrite (7.1.12) more simply as

$$\cosh x = \sum_{m=0}^{\infty} \frac{x^{2m}}{(2m)!}.$$

This result is valid on  $(-\infty, \infty)$ , since this is the open interval of convergence of the Maclaurin series for  $e^x$  and  $e^{-x}$ .

**Example 7.1.6** Suppose

$$y = \sum_{n=0}^{\infty} a_n x^n$$

on an open interval  $I$  that contains the origin.

(a) Express

$$(2-x)y'' + 2y$$

as a power series in  $x$  on  $I$ .



- (b) Use the result of (a) to find necessary and sufficient conditions on the coefficients  $\{a_n\}$  for  $y$  to be a solution of the homogeneous equation

$$(2 - x)y'' + 2y = 0 \quad (7.1.13)$$

on  $I$ .

**SOLUTION(a)** From (7.1.7) with  $x_0 = 0$ ,

$$y'' = \sum_{n=2}^{\infty} n(n-1)a_n x^{n-2}.$$

Therefore

$$\begin{aligned} (2 - x)y'' + 2y &= 2y'' - xy' + 2y \\ &= \sum_{n=2}^{\infty} 2n(n-1)a_n x^{n-2} - \sum_{n=2}^{\infty} n(n-1)a_n x^{n-1} + \sum_{n=0}^{\infty} 2a_n x^n. \end{aligned} \quad (7.1.14)$$

To combine the three series we shift indices in the first two to make their general terms constant multiples of  $x^n$ ; thus,

$$\sum_{n=2}^{\infty} 2n(n-1)a_n x^{n-2} = \sum_{n=0}^{\infty} 2(n+2)(n+1)a_{n+2} x^n \quad (7.1.15)$$

and

$$\sum_{n=2}^{\infty} n(n-1)a_n x^{n-1} = \sum_{n=1}^{\infty} (n+1)na_{n+1} x^n = \sum_{n=0}^{\infty} (n+1)na_{n+1} x^n, \quad (7.1.16)$$

where we added a zero term in the last series so that when we substitute from (7.1.15) and (7.1.16) into (7.1.14) all three series will start with  $n = 0$ ; thus,

$$(2 - x)y'' + 2y = \sum_{n=0}^{\infty} [2(n+2)(n+1)a_{n+2} - (n+1)na_{n+1} + 2a_n]x^n. \quad (7.1.17)$$

**SOLUTION(b)** From (7.1.17) we see that  $y$  satisfies (7.1.13) on  $I$  if

$$2(n+2)(n+1)a_{n+2} - (n+1)na_{n+1} + 2a_n = 0, \quad n = 0, 1, 2, \dots \quad (7.1.18)$$

Conversely, Theorem 7.1.6 (b) implies that if  $y = \sum_{n=0}^{\infty} a_n x^n$  satisfies (7.1.13) on  $I$ , then (7.1.18) holds.

**Example 7.1.7** Suppose

$$y = \sum_{n=0}^{\infty} a_n (x-1)^n$$

on an open interval  $I$  that contains  $x_0 = 1$ . Express the function

$$(1+x)y'' + 2(x-1)^2 y' + 3y \quad (7.1.19)$$

as a power series in  $x-1$  on  $I$ .

**Solution** Since we want a power series in  $x - 1$ , we rewrite the coefficient of  $y''$  in (7.1.19) as  $1 + x = 2 + (x - 1)$ , so (7.1.19) becomes

$$2y'' + (x - 1)y'' + 2(x - 1)^2y' + 3y.$$

From (7.1.6) and (7.1.7) with  $x_0 = 1$ ,

$$y' = \sum_{n=1}^{\infty} na_n(x - 1)^{n-1} \quad \text{and} \quad y'' = \sum_{n=2}^{\infty} n(n - 1)a_n(x - 1)^{n-2}.$$

Therefore

$$\begin{aligned} 2y'' &= \sum_{n=2}^{\infty} 2n(n - 1)a_n(x - 1)^{n-2}, \\ (x - 1)y'' &= \sum_{n=2}^{\infty} n(n - 1)a_n(x - 1)^{n-1}, \\ 2(x - 1)^2y' &= \sum_{n=1}^{\infty} 2na_n(x - 1)^{n+1}, \\ 3y &= \sum_{n=0}^{\infty} 3a_n(x - 1)^n. \end{aligned}$$

Before adding these four series we shift indices in the first three so that their general terms become constant multiples of  $(x - 1)^n$ . This yields

$$2y'' = \sum_{n=0}^{\infty} 2(n + 2)(n + 1)a_{n+2}(x - 1)^n, \quad (7.1.20)$$

$$(x - 1)y'' = \sum_{n=0}^{\infty} (n + 1)na_{n+1}(x - 1)^n, \quad (7.1.21)$$

$$2(x - 1)^2y' = \sum_{n=1}^{\infty} 2(n - 1)a_{n-1}(x - 1)^n, \quad (7.1.22)$$

$$3y = \sum_{n=0}^{\infty} 3a_n(x - 1)^n, \quad (7.1.23)$$

where we added initial zero terms to the series in (7.1.21) and (7.1.22). Adding (7.1.20)–(7.1.23) yields

$$\begin{aligned} (1 + x)y'' + 2(x - 1)^2y' + 3y &= 2y'' + (x - 1)y'' + 2(x - 1)^2y' + 3y \\ &= \sum_{n=0}^{\infty} b_n(x - 1)^n, \end{aligned}$$

where

$$b_0 = 4a_2 + 3a_0, \quad (7.1.24)$$

$$b_n = 2(n + 2)(n + 1)a_{n+2} + (n + 1)na_{n+1} + 2(n - 1)a_{n-1} + 3a_n, \quad n \geq 1. \quad (7.1.25)$$

The formula (7.1.24) for  $b_0$  can't be obtained by setting  $n = 0$  in (7.1.25), since the summation in (7.1.22) begins with  $n = 1$ , while those in (7.1.20), (7.1.21), and (7.1.23) begin with  $n = 0$ .

## 7.1 Exercises

1. For each power series use Theorem 7.1.3 to find the radius of convergence  $R$ . If  $R > 0$ , find the open interval of convergence.

$$(a) \sum_{n=0}^{\infty} \frac{(-1)^n}{2^n n} (x-1)^n$$

$$(b) \sum_{n=0}^{\infty} 2^n n (x-2)^n$$

$$(c) \sum_{n=0}^{\infty} \frac{n!}{9^n} x^n$$

$$(d) \sum_{n=0}^{\infty} \frac{n(n+1)}{16^n} (x-2)^n$$

$$(e) \sum_{n=0}^{\infty} (-1)^n \frac{7^n}{n!} x^n$$

$$(f) \sum_{n=0}^{\infty} \frac{3^n}{4^{n+1}(n+1)^2} (x+7)^n$$

2. Suppose there's an integer  $M$  such that  $b_m \neq 0$  for  $m \geq M$ , and

$$\lim_{m \rightarrow \infty} \left| \frac{b_{m+1}}{b_m} \right| = L,$$

where  $0 \leq L \leq \infty$ . Show that the radius of convergence of

$$\sum_{m=0}^{\infty} b_m (x-x_0)^{2m}$$

is  $R = 1/\sqrt{L}$ , which is interpreted to mean that  $R = 0$  if  $L = \infty$  or  $R = \infty$  if  $L = 0$ . HINT: Apply Theorem 7.1.3 to the series  $\sum_{m=0}^{\infty} b_m z^m$  and then let  $z = (x-x_0)^2$ .

3. For each power series, use the result of Exercise 2 to find the radius of convergence  $R$ . If  $R > 0$ , find the open interval of convergence.

$$(a) \sum_{m=0}^{\infty} (-1)^m (3m+1) (x-1)^{2m+1}$$

$$(b) \sum_{m=0}^{\infty} (-1)^m \frac{m(2m+1)}{2^m} (x+2)^{2m}$$

$$(c) \sum_{m=0}^{\infty} \frac{m!}{(2m)!} (x-1)^{2m}$$

$$(d) \sum_{m=0}^{\infty} (-1)^m \frac{m!}{9^m} (x+8)^{2m}$$

$$(e) \sum_{m=0}^{\infty} (-1)^m \frac{(2m-1)}{3^m} x^{2m+1}$$

$$(f) \sum_{m=0}^{\infty} (x-1)^{2m}$$

4. Suppose there's an integer  $M$  such that  $b_m \neq 0$  for  $m \geq M$ , and

$$\lim_{m \rightarrow \infty} \left| \frac{b_{m+1}}{b_m} \right| = L,$$

where  $0 \leq L \leq \infty$ . Let  $k$  be a positive integer. Show that the radius of convergence of

$$\sum_{m=0}^{\infty} b_m (x-x_0)^{km}$$

is  $R = 1/\sqrt[k]{L}$ , which is interpreted to mean that  $R = 0$  if  $L = \infty$  or  $R = \infty$  if  $L = 0$ . HINT: Apply Theorem 7.1.3 to the series  $\sum_{m=0}^{\infty} b_m z^m$  and then let  $z = (x-x_0)^k$ .

5. For each power series use the result of Exercise 4 to find the radius of convergence  $R$ . If  $R > 0$ , find the open interval of convergence.

$$\begin{array}{ll}
 \text{(a)} \sum_{m=0}^{\infty} \frac{(-1)^m}{(27)^m} (x-3)^{3m+2} & \text{(b)} \sum_{m=0}^{\infty} \frac{x^{7m+6}}{m} \\
 \text{(c)} \sum_{m=0}^{\infty} \frac{9^m(m+1)}{(m+2)} (x-3)^{4m+2} & \text{(d)} \sum_{m=0}^{\infty} (-1)^m \frac{2^m}{m!} x^{4m+3} \\
 \text{(e)} \sum_{m=0}^{\infty} \frac{m!}{(26)^m} (x+1)^{4m+3} & \text{(f)} \sum_{m=0}^{\infty} \frac{(-1)^m}{8^m m(m+1)} (x-1)^{3m+1}
 \end{array}$$

6. **L** Graph  $y = \sin x$  and the Taylor polynomial

$$T_{2M+1}(x) = \sum_{n=0}^M \frac{(-1)^n x^{2n+1}}{(2n+1)!}$$

on the interval  $(-2\pi, 2\pi)$  for  $M = 1, 2, 3, \dots$ , until you find a value of  $M$  for which there's no perceptible difference between the two graphs.

7. **L** Graph  $y = \cos x$  and the Taylor polynomial

$$T_{2M}(x) = \sum_{n=0}^M \frac{(-1)^n x^{2n}}{(2n)!}$$

on the interval  $(-2\pi, 2\pi)$  for  $M = 1, 2, 3, \dots$ , until you find a value of  $M$  for which there's no perceptible difference between the two graphs.

8. **L** Graph  $y = 1/(1-x)$  and the Taylor polynomial

$$T_N(x) = \sum_{n=0}^N x^n$$

on the interval  $[0, .95]$  for  $N = 1, 2, 3, \dots$ , until you find a value of  $N$  for which there's no perceptible difference between the two graphs. Choose the scale on the  $y$ -axis so that  $0 \leq y \leq 20$ .

9. **L** Graph  $y = \cosh x$  and the Taylor polynomial

$$T_{2M}(x) = \sum_{n=0}^M \frac{x^{2n}}{(2n)!}$$

on the interval  $(-5, 5)$  for  $M = 1, 2, 3, \dots$ , until you find a value of  $M$  for which there's no perceptible difference between the two graphs. Choose the scale on the  $y$ -axis so that  $0 \leq y \leq 75$ .

10. **L** Graph  $y = \sinh x$  and the Taylor polynomial

$$T_{2M+1}(x) = \sum_{n=0}^M \frac{x^{2n+1}}{(2n+1)!}$$

on the interval  $(-5, 5)$  for  $M = 0, 1, 2, \dots$ , until you find a value of  $M$  for which there's no perceptible difference between the two graphs. Choose the scale on the  $y$ -axis so that  $-75 \leq y \leq 75$ .

In Exercises 11–15 find a power series solution  $y(x) = \sum_{n=0}^{\infty} a_n x^n$ .

11.  $(2+x)y'' + xy' + 3y$

12.  $(1+3x^2)y'' + 3x^2y' - 2y$

13.  $(1+2x^2)y'' + (2-3x)y' + 4y$

14.  $(1+x^2)y'' + (2-x)y' + 3y$

15.  $(1 + 3x^2)y'' - 2xy' + 4y$
16. Suppose  $y(x) = \sum_{n=0}^{\infty} a_n(x+1)^n$  on an open interval that contains  $x_0 = -1$ . Find a power series in  $x+1$  for

$$xy'' + (4 + 2x)y' + (2 + x)y.$$

17. Suppose  $y(x) = \sum_{n=0}^{\infty} a_n(x-2)^n$  on an open interval that contains  $x_0 = 2$ . Find a power series in  $x-2$  for

$$x^2y'' + 2xy' - 3xy.$$

18. **L** Do the following experiment for various choices of real numbers  $a_0$  and  $a_1$ .

- (a) Use differential equations software to solve the initial value problem

$$(2-x)y'' + 2y = 0, \quad y(0) = a_0, \quad y'(0) = a_1,$$

numerically on  $(-1.95, 1.95)$ . Choose the most accurate method your software package provides. (See Section 10.1 for a brief discussion of one such method.)

- (b) For  $N = 2, 3, 4, \dots$ , compute  $a_2, \dots, a_N$  from Eqn.(7.1.18) and graph

$$T_N(x) = \sum_{n=0}^N a_n x^n$$

and the solution obtained in (a) on the same axes. Continue increasing  $N$  until it's obvious that there's no point in continuing. (This sounds vague, but you'll know when to stop.)

19. **L** Follow the directions of Exercise 18 for the initial value problem

$$(1+x)y'' + 2(x-1)^2y' + 3y = 0, \quad y(1) = a_0, \quad y'(1) = a_1,$$

on the interval  $(0, 2)$ . Use Eqns. (7.1.24) and (7.1.25) to compute  $\{a_n\}$ .

20. Suppose the series  $\sum_{n=0}^{\infty} a_n x^n$  converges on an open interval  $(-R, R)$ , let  $r$  be an arbitrary real number, and define

$$y(x) = x^r \sum_{n=0}^{\infty} a_n x^n = \sum_{n=0}^{\infty} a_n x^{n+r}$$

on  $(0, R)$ . Use Theorem 7.1.4 and the rule for differentiating the product of two functions to show that

$$\begin{aligned} y'(x) &= \sum_{n=0}^{\infty} (n+r)a_n x^{n+r-1}, \\ y''(x) &= \sum_{n=0}^{\infty} (n+r)(n+r-1)a_n x^{n+r-2}, \\ &\vdots \\ y^{(k)}(x) &= \sum_{n=0}^{\infty} (n+r)(n+r-1)\cdots(n+r-k)a_n x^{n+r-k} \end{aligned}$$

on  $(0, R)$

In Exercises 21–26 let  $y$  be as defined in Exercise 20, and write the given expression in the form  $x^r \sum_{n=0}^{\infty} b_n x^n$ .

21.  $x^2(1-x)y'' + x(4+x)y' + (2-x)y$
22.  $x^2(1+x)y'' + x(1+2x)y' - (4+6x)y$
23.  $x^2(1+x)y'' - x(1-6x-x^2)y' + (1+6x+x^2)y$
24.  $x^2(1+3x)y'' + x(2+12x+x^2)y' + 2x(3+x)y$
25.  $x^2(1+2x^2)y'' + x(4+2x^2)y' + 2(1-x^2)y$
26.  $x^2(2+x^2)y'' + 2x(5+x^2)y' + 2(3-x^2)y$

## 7.2 SERIES SOLUTIONS NEAR AN ORDINARY POINT I

Many physical applications give rise to second order homogeneous linear differential equations of the form

$$P_0(x)y'' + P_1(x)y' + P_2(x)y = 0, \quad (7.2.1)$$

where  $P_0$ ,  $P_1$ , and  $P_2$  are polynomials. Usually the solutions of these equations can't be expressed in terms of familiar elementary functions. Therefore we'll consider the problem of representing solutions of (7.2.1) with series.

We assume throughout that  $P_0$ ,  $P_1$  and  $P_2$  have no common factors. Then we say that  $x_0$  is an *ordinary point* of (7.2.1) if  $P_0(x_0) \neq 0$ , or a *singular point* if  $P_0(x_0) = 0$ . For Legendre's equation,

$$(1-x^2)y'' - 2xy' + \alpha(\alpha+1)y = 0, \quad (7.2.2)$$

$x_0 = 1$  and  $x_0 = -1$  are singular points and all other points are ordinary points. For Bessel's equation,

$$x^2y'' + xy' + (x^2 - \nu^2)y = 0,$$

$x_0 = 0$  is a singular point and all other points are ordinary points. If  $P_0$  is a nonzero constant as in Airy's equation,

$$y'' - xy = 0, \quad (7.2.3)$$

then every point is an ordinary point.

Since polynomials are continuous everywhere,  $P_1/P_0$  and  $P_2/P_0$  are continuous at any point  $x_0$  that isn't a zero of  $P_0$ . Therefore, if  $x_0$  is an ordinary point of (7.2.1) and  $a_0$  and  $a_1$  are arbitrary real numbers, then the initial value problem

$$P_0(x)y'' + P_1(x)y' + P_2(x)y = 0, \quad y(x_0) = a_0, \quad y'(x_0) = a_1 \quad (7.2.4)$$

has a unique solution on the largest open interval that contains  $x_0$  and does not contain any zeros of  $P_0$ . To see this, we rewrite the differential equation in (7.2.4) as

$$y'' + \frac{P_1(x)}{P_0(x)}y' + \frac{P_2(x)}{P_0(x)}y = 0$$

and apply Theorem 5.1.1 with  $p = P_1/P_0$  and  $q = P_2/P_0$ . In this section and the next we consider the problem of representing solutions of (7.2.1) by power series that converge for values of  $x$  near an ordinary point  $x_0$ .

We state the next theorem without proof.

**Theorem 7.2.1** Suppose  $P_0$ ,  $P_1$ , and  $P_2$  are polynomials with no common factor and  $P_0$  isn't identically zero. Let  $x_0$  be a point such that  $P_0(x_0) \neq 0$ , and let  $\rho$  be the distance from  $x_0$  to the nearest zero of  $P_0$  in the complex plane. (If  $P_0$  is constant, then  $\rho = \infty$ .) Then every solution of

$$P_0(x)y'' + P_1(x)y' + P_2(x)y = 0 \quad (7.2.5)$$

can be represented by a power series

$$y = \sum_{n=0}^{\infty} a_n(x - x_0)^n \quad (7.2.6)$$

that converges at least on the open interval  $(x_0 - \rho, x_0 + \rho)$ . (If  $P_0$  is nonconstant, so that  $\rho$  is necessarily finite, then the open interval of convergence of (7.2.6) may be larger than  $(x_0 - \rho, x_0 + \rho)$ . If  $P_0$  is constant then  $\rho = \infty$  and  $(x_0 - \rho, x_0 + \rho) = (-\infty, \infty)$ .)

We call (7.2.6) a *power series solution in  $x - x_0$*  of (7.2.5). We'll now develop a method for finding power series solutions of (7.2.5). For this purpose we write (7.2.5) as  $Ly = 0$ , where

$$Ly = P_0y'' + P_1y' + P_2y. \quad (7.2.7)$$

Theorem 7.2.1 implies that every solution of  $Ly = 0$  on  $(x_0 - \rho, x_0 + \rho)$  can be written as

$$y = \sum_{n=0}^{\infty} a_n(x - x_0)^n.$$

Setting  $x = x_0$  in this series and in the series

$$y' = \sum_{n=1}^{\infty} na_n(x - x_0)^{n-1}$$

shows that  $y(x_0) = a_0$  and  $y'(x_0) = a_1$ . Since every initial value problem (7.2.4) has a unique solution, this means that  $a_0$  and  $a_1$  can be chosen arbitrarily, and  $a_2, a_3, \dots$  are uniquely determined by them.

To find  $a_2, a_3, \dots$ , we write  $P_0, P_1$ , and  $P_2$  in powers of  $x - x_0$ , substitute

$$\begin{aligned} y &= \sum_{n=0}^{\infty} a_n(x - x_0)^n, \\ y' &= \sum_{n=1}^{\infty} na_n(x - x_0)^{n-1}, \\ y'' &= \sum_{n=2}^{\infty} n(n-1)a_n(x - x_0)^{n-2} \end{aligned}$$

into (7.2.7), and collect the coefficients of like powers of  $x - x_0$ . This yields

$$Ly = \sum_{n=0}^{\infty} b_n(x - x_0)^n, \quad (7.2.8)$$

where  $\{b_0, b_1, \dots, b_n, \dots\}$  are expressed in terms of  $\{a_0, a_1, \dots, a_n, \dots\}$  and the coefficients of  $P_0, P_1$ , and  $P_2$ , written in powers of  $x - x_0$ . Since (7.2.8) and (a) of Theorem 7.1.6 imply that  $Ly = 0$  if and only if  $b_n = 0$  for  $n \geq 0$ , all power series solutions in  $x - x_0$  of  $Ly = 0$  can be obtained by choosing  $a_0$  and  $a_1$  arbitrarily and computing  $a_2, a_3, \dots$ , successively so that  $b_n = 0$  for  $n \geq 0$ . For simplicity, we call the power series obtained this way *the power series in  $x - x_0$  for the general solution* of  $Ly = 0$ , without explicitly identifying the open interval of convergence of the series.

**Example 7.2.1** Let  $x_0$  be an arbitrary real number. Find the power series in  $x - x_0$  for the general solution of

$$y'' + y = 0. \quad (7.2.9)$$

**Solution** Here

$$Ly = y'' + y.$$

If

$$y = \sum_{n=0}^{\infty} a_n (x - x_0)^n,$$

then

$$y'' = \sum_{n=2}^{\infty} n(n-1)a_n (x - x_0)^{n-2},$$

so

$$Ly = \sum_{n=2}^{\infty} n(n-1)a_n (x - x_0)^{n-2} + \sum_{n=0}^{\infty} a_n (x - x_0)^n.$$

To collect coefficients of like powers of  $x - x_0$ , we shift the summation index in the first sum. This yields

$$Ly = \sum_{n=0}^{\infty} (n+2)(n+1)a_{n+2} (x - x_0)^n + \sum_{n=0}^{\infty} a_n (x - x_0)^n = \sum_{n=0}^{\infty} b_n (x - x_0)^n,$$

with

$$b_n = (n+2)(n+1)a_{n+2} + a_n.$$

Therefore  $Ly = 0$  if and only if

$$a_{n+2} = \frac{-a_n}{(n+2)(n+1)}, \quad n \geq 0, \quad (7.2.10)$$

where  $a_0$  and  $a_1$  are arbitrary. Since the indices on the left and right sides of (7.2.10) differ by two, we write (7.2.10) separately for  $n$  even ( $n = 2m$ ) and  $n$  odd ( $n = 2m + 1$ ). This yields

$$a_{2m+2} = \frac{-a_{2m}}{(2m+2)(2m+1)}, \quad m \geq 0, \quad (7.2.11)$$

and

$$a_{2m+3} = \frac{-a_{2m+1}}{(2m+3)(2m+2)}, \quad m \geq 0. \quad (7.2.12)$$

Computing the coefficients of the even powers of  $x - x_0$  from (7.2.11) yields

$$\begin{aligned} a_2 &= -\frac{a_0}{2 \cdot 1} \\ a_4 &= -\frac{a_2}{4 \cdot 3} = -\frac{1}{4 \cdot 3} \left( -\frac{a_0}{2 \cdot 1} \right) = \frac{a_0}{4 \cdot 3 \cdot 2 \cdot 1}, \\ a_6 &= -\frac{a_4}{6 \cdot 5} = -\frac{1}{6 \cdot 5} \left( \frac{a_0}{4 \cdot 3 \cdot 2 \cdot 1} \right) = -\frac{a_0}{6 \cdot 5 \cdot 4 \cdot 3 \cdot 2 \cdot 1}, \end{aligned}$$

and, in general,

$$a_{2m} = (-1)^m \frac{a_0}{(2m)!}, \quad m \geq 0. \quad (7.2.13)$$



Computing the coefficients of the odd powers of  $x - x_0$  from (7.2.12) yields

$$\begin{aligned} a_3 &= -\frac{a_1}{3 \cdot 2} \\ a_5 &= -\frac{a_3}{5 \cdot 4} = -\frac{1}{5 \cdot 4} \left( -\frac{a_1}{3 \cdot 2} \right) = \frac{a_1}{5 \cdot 4 \cdot 3 \cdot 2}, \\ a_7 &= -\frac{a_5}{7 \cdot 6} = -\frac{1}{7 \cdot 6} \left( \frac{a_1}{5 \cdot 4 \cdot 3 \cdot 2} \right) = -\frac{a_1}{7 \cdot 6 \cdot 5 \cdot 4 \cdot 3 \cdot 2}, \end{aligned}$$

and, in general,

$$a_{2m+1} = \frac{(-1)^m a_1}{(2m+1)!} \quad m \geq 0. \quad (7.2.14)$$

Thus, the general solution of (7.2.9) can be written as

$$y = \sum_{m=0}^{\infty} a_{2m} (x - x_0)^{2m} + \sum_{m=0}^{\infty} a_{2m+1} (x - x_0)^{2m+1},$$

or, from (7.2.13) and (7.2.14), as

$$y = a_0 \sum_{m=0}^{\infty} (-1)^m \frac{(x - x_0)^{2m}}{(2m)!} + a_1 \sum_{m=0}^{\infty} (-1)^m \frac{(x - x_0)^{2m+1}}{(2m+1)!}. \quad (7.2.15)$$

If we recall from calculus that

$$\sum_{m=0}^{\infty} (-1)^m \frac{(x - x_0)^{2m}}{(2m)!} = \cos(x - x_0) \quad \text{and} \quad \sum_{m=0}^{\infty} (-1)^m \frac{(x - x_0)^{2m+1}}{(2m+1)!} = \sin(x - x_0),$$

then (7.2.15) becomes

$$y = a_0 \cos(x - x_0) + a_1 \sin(x - x_0),$$

which should look familiar. ■

Equations like (7.2.10), (7.2.11), and (7.2.12), which define a given coefficient in the sequence  $\{a_n\}$  in terms of one or more coefficients with lesser indices are called *recurrence relations*. When we use a recurrence relation to compute terms of a sequence we're computing *recursively*.

In the remainder of this section we consider the problem of finding power series solutions in  $x - x_0$  for equations of the form

$$(1 + \alpha(x - x_0)^2) y'' + \beta(x - x_0) y' + \gamma y = 0. \quad (7.2.16)$$

Many important equations that arise in applications are of this form with  $x_0 = 0$ , including Legendre's equation (7.2.2), Airy's equation (7.2.3), *Chebyshev's equation*,

$$(1 - x^2) y'' - x y' + \alpha^2 y = 0,$$

and *Hermite's equation*,

$$y'' - 2x y' + 2\alpha y = 0.$$

Since

$$P_0(x) = 1 + \alpha(x - x_0)^2$$

in (7.2.16), the point  $x_0$  is an ordinary point of (7.2.16), and Theorem 7.2.1 implies that the solutions of (7.2.16) can be written as power series in  $x - x_0$  that converge on the interval  $(x_0 - 1/\sqrt{|\alpha|}, x_0 + 1/\sqrt{|\alpha|})$

if  $\alpha \neq 0$ , or on  $(-\infty, \infty)$  if  $\alpha = 0$ . We'll see that the coefficients in these power series can be obtained by methods similar to the one used in Example 7.2.1.

To simplify finding the coefficients, we introduce some notation for products:

$$\prod_{j=r}^s b_j = b_r b_{r+1} \cdots b_s \quad \text{if } s \geq r.$$

Thus,

$$\prod_{j=2}^7 b_j = b_2 b_3 b_4 b_5 b_6 b_7,$$

$$\prod_{j=0}^4 (2j+1) = (1)(3)(5)(7)(9) = 945,$$

and

$$\prod_{j=2}^2 j^2 = 2^2 = 4.$$

We define

$$\prod_{j=r}^s b_j = 1 \quad \text{if } s < r,$$

no matter what the form of  $b_j$ .

**Example 7.2.2** Find the power series in  $x$  for the general solution of

$$(1 + 2x^2)y'' + 6xy' + 2y = 0. \quad (7.2.17)$$

**Solution** Here

$$Ly = (1 + 2x^2)y'' + 6xy' + 2y.$$

If

$$y = \sum_{n=0}^{\infty} a_n x^n$$

then

$$y' = \sum_{n=1}^{\infty} n a_n x^{n-1} \quad \text{and} \quad y'' = \sum_{n=2}^{\infty} n(n-1) a_n x^{n-2},$$

so

$$\begin{aligned} Ly &= (1 + 2x^2) \sum_{n=2}^{\infty} n(n-1) a_n x^{n-2} + 6x \sum_{n=1}^{\infty} n a_n x^{n-1} + 2 \sum_{n=0}^{\infty} a_n x^n \\ &= \sum_{n=2}^{\infty} n(n-1) a_n x^{n-2} + \sum_{n=0}^{\infty} [2n(n-1) + 6n + 2] a_n x^n \\ &= \sum_{n=2}^{\infty} n(n-1) a_n x^{n-2} + 2 \sum_{n=0}^{\infty} (n+1)^2 a_n x^n. \end{aligned}$$

To collect coefficients of  $x^n$ , we shift the summation index in the first sum. This yields

$$Ly = \sum_{n=0}^{\infty} (n+2)(n+1)a_{n+2}x^n + 2 \sum_{n=0}^{\infty} (n+1)^2 a_n x^n = \sum_{n=0}^{\infty} b_n x^n,$$

with

$$b_n = (n+2)(n+1)a_{n+2} + 2(n+1)^2 a_n, \quad n \geq 0.$$

To obtain solutions of (7.2.17), we set  $b_n = 0$  for  $n \geq 0$ . This is equivalent to the recurrence relation

$$a_{n+2} = -2 \frac{n+1}{n+2} a_n, \quad n \geq 0. \quad (7.2.18)$$

Since the indices on the left and right differ by two, we write (7.2.18) separately for  $n = 2m$  and  $n = 2m + 1$ , as in Example 7.2.1. This yields

$$a_{2m+2} = -2 \frac{2m+1}{2m+2} a_{2m} = -\frac{2m+1}{m+1} a_{2m}, \quad m \geq 0, \quad (7.2.19)$$

and

$$a_{2m+3} = -2 \frac{2m+2}{2m+3} a_{2m+1} = -4 \frac{m+1}{2m+3} a_{2m+1}, \quad m \geq 0. \quad (7.2.20)$$

Computing the coefficients of even powers of  $x$  from (7.2.19) yields

$$\begin{aligned} a_2 &= -\frac{1}{1} a_0, \\ a_4 &= -\frac{3}{2} a_2 = \left(-\frac{3}{2}\right) \left(-\frac{1}{1}\right) a_0 = \frac{1 \cdot 3}{1 \cdot 2} a_0, \\ a_6 &= -\frac{5}{3} a_4 = -\frac{5}{3} \left(\frac{1 \cdot 3}{1 \cdot 2}\right) a_0 = -\frac{1 \cdot 3 \cdot 5}{1 \cdot 2 \cdot 3} a_0, \\ a_8 &= -\frac{7}{4} a_6 = -\frac{7}{4} \left(-\frac{1 \cdot 3 \cdot 5}{1 \cdot 2 \cdot 3}\right) a_0 = \frac{1 \cdot 3 \cdot 5 \cdot 7}{1 \cdot 2 \cdot 3 \cdot 4} a_0. \end{aligned}$$

In general,

$$a_{2m} = (-1)^m \frac{\prod_{j=1}^m (2j-1)}{m!} a_0, \quad m \geq 0. \quad (7.2.21)$$

(Note that (7.2.21) is correct for  $m = 0$  because we defined  $\prod_{j=1}^0 b_j = 1$  for any  $b_j$ .)

Computing the coefficients of odd powers of  $x$  from (7.2.20) yields

$$\begin{aligned} a_3 &= -4 \frac{1}{3} a_1, \\ a_5 &= -4 \frac{2}{5} a_3 = -4 \frac{2}{5} \left(-4 \frac{1}{3}\right) a_1 = 4^2 \frac{1 \cdot 2}{3 \cdot 5} a_1, \\ a_7 &= -4 \frac{3}{7} a_5 = -4 \frac{3}{7} \left(4^2 \frac{1 \cdot 2}{3 \cdot 5}\right) a_1 = -4^3 \frac{1 \cdot 2 \cdot 3}{3 \cdot 5 \cdot 7} a_1, \\ a_9 &= -4 \frac{4}{9} a_7 = -4 \frac{4}{9} \left(-4^3 \frac{1 \cdot 2 \cdot 3}{3 \cdot 5 \cdot 7}\right) a_1 = 4^4 \frac{1 \cdot 2 \cdot 3 \cdot 4}{3 \cdot 5 \cdot 7 \cdot 9} a_1. \end{aligned}$$

In general,

$$a_{2m+1} = \frac{(-1)^m 4^m m!}{\prod_{j=1}^m (2j+1)} a_1, \quad m \geq 0. \quad (7.2.22)$$

From (7.2.21) and (7.2.22),

$$y = a_0 \sum_{m=0}^{\infty} (-1)^m \frac{\prod_{j=1}^m (2j-1)}{m!} x^{2m} + a_1 \sum_{m=0}^{\infty} (-1)^m \frac{4^m m!}{\prod_{j=1}^m (2j+1)} x^{2m+1}.$$

is the power series in  $x$  for the general solution of (7.2.17). Since  $P_0(x) = 1+2x^2$  has no real zeros, Theorem 5.1.1 implies that every solution of (7.2.17) is defined on  $(-\infty, \infty)$ . However, since  $P_0(\pm i/\sqrt{2}) = 0$ , Theorem 7.2.1 implies only that the power series converges in  $(-1/\sqrt{2}, 1/\sqrt{2})$  for any choice of  $a_0$  and  $a_1$ .

The results in Examples 7.2.1 and 7.2.2 are consequences of the following general theorem.

**Theorem 7.2.2** *The coefficients  $\{a_n\}$  in any solution  $y = \sum_{n=0}^{\infty} a_n(x-x_0)^n$  of*

$$(1 + \alpha(x-x_0)^2)y'' + \beta(x-x_0)y' + \gamma y = 0 \quad (7.2.23)$$

*satisfy the recurrence relation*

$$a_{n+2} = -\frac{p(n)}{(n+2)(n+1)} a_n, \quad n \geq 0, \quad (7.2.24)$$

*where*

$$p(n) = \alpha n(n-1) + \beta n + \gamma. \quad (7.2.25)$$

*Moreover, the coefficients of the even and odd powers of  $x-x_0$  can be computed separately as*

$$a_{2m+2} = -\frac{p(2m)}{(2m+2)(2m+1)} a_{2m}, \quad m \geq 0 \quad (7.2.26)$$

*and*

$$a_{2m+3} = -\frac{p(2m+1)}{(2m+3)(2m+2)} a_{2m+1}, \quad m \geq 0, \quad (7.2.27)$$

*where  $a_0$  and  $a_1$  are arbitrary.*

**Proof** Here

$$Ly = (1 + \alpha(x-x_0)^2)y'' + \beta(x-x_0)y' + \gamma y.$$

If

$$y = \sum_{n=0}^{\infty} a_n(x-x_0)^n,$$

then

$$y' = \sum_{n=1}^{\infty} n a_n(x-x_0)^{n-1} \quad \text{and} \quad y'' = \sum_{n=2}^{\infty} n(n-1) a_n(x-x_0)^{n-2}.$$

Hence,

$$\begin{aligned} Ly &= \sum_{n=2}^{\infty} n(n-1) a_n(x-x_0)^{n-2} + \sum_{n=0}^{\infty} [\alpha n(n-1) + \beta n + \gamma] a_n(x-x_0)^n \\ &= \sum_{n=2}^{\infty} n(n-1) a_n(x-x_0)^{n-2} + \sum_{n=0}^{\infty} p(n) a_n(x-x_0)^n, \end{aligned}$$

from (7.2.25). To collect coefficients of powers of  $x - x_0$ , we shift the summation index in the first sum. This yields

$$Ly = \sum_{n=0}^{\infty} [(n+2)(n+1)a_{n+2} + p(n)a_n] (x - x_0)^n.$$

Thus,  $Ly = 0$  if and only if

$$(n+2)(n+1)a_{n+2} + p(n)a_n = 0, \quad n \geq 0,$$

which is equivalent to (7.2.24). Writing (7.2.24) separately for the cases where  $n = 2m$  and  $n = 2m + 1$  yields (7.2.26) and (7.2.27).

**Example 7.2.3** Find the power series in  $x - 1$  for the general solution of

$$(2 + 4x - 2x^2)y'' - 12(x - 1)y' - 12y = 0. \quad (7.2.28)$$

**Solution** We must first write the coefficient  $P_0(x) = 2 + 4x - x^2$  in powers of  $x - 1$ . To do this, we write  $x = (x - 1) + 1$  in  $P_0(x)$  and then expand the terms, collecting powers of  $x - 1$ ; thus,

$$\begin{aligned} 2 + 4x - 2x^2 &= 2 + 4[(x - 1) + 1] - 2[(x - 1) + 1]^2 \\ &= 4 - 2(x - 1)^2. \end{aligned}$$

Therefore we can rewrite (7.2.28) as

$$(4 - 2(x - 1)^2)y'' - 12(x - 1)y' - 12y = 0,$$

or, equivalently,

$$\left(1 - \frac{1}{2}(x - 1)^2\right)y'' - 3(x - 1)y' - 3y = 0.$$

This is of the form (7.2.23) with  $\alpha = -1/2$ ,  $\beta = -3$ , and  $\gamma = -3$ . Therefore, from (7.2.25)

$$p(n) = -\frac{n(n-1)}{2} - 3n - 3 = -\frac{(n+2)(n+3)}{2}.$$

Hence, Theorem 7.2.2 implies that

$$\begin{aligned} a_{2m+2} &= -\frac{p(2m)}{(2m+2)(2m+1)}a_{2m} \\ &= \frac{(2m+2)(2m+3)}{2(2m+2)(2m+1)}a_{2m} = \frac{2m+3}{2(2m+1)}a_{2m}, \quad m \geq 0 \end{aligned}$$

and

$$\begin{aligned} a_{2m+3} &= -\frac{p(2m+1)}{(2m+3)(2m+2)}a_{2m+1} \\ &= \frac{(2m+3)(2m+4)}{2(2m+3)(2m+2)}a_{2m+1} = \frac{m+2}{2(m+1)}a_{2m+1}, \quad m \geq 0. \end{aligned}$$

We leave it to you to show that

$$a_{2m} = \frac{2m+1}{2^m}a_0 \quad \text{and} \quad a_{2m+1} = \frac{m+1}{2^m}a_1, \quad m \geq 0,$$

which implies that the power series in  $x - 1$  for the general solution of (7.2.28) is

$$y = a_0 \sum_{m=0}^{\infty} \frac{2m+1}{2^m} (x-1)^{2m} + a_1 \sum_{m=0}^{\infty} \frac{m+1}{2^m} (x-1)^{2m+1}. \blacksquare$$

In the examples considered so far we were able to obtain closed formulas for coefficients in the power series solutions. In some cases this is impossible, and we must settle for computing a finite number of terms in the series. The next example illustrates this with an initial value problem.

**Example 7.2.4** Compute  $a_0, a_1, \dots, a_7$  in the series solution  $y = \sum_{n=0}^{\infty} a_n x^n$  of the initial value problem

$$(1 + 2x^2)y'' + 10xy' + 8y = 0, \quad y(0) = 2, \quad y'(0) = -3. \quad (7.2.29)$$

**Solution** Since  $\alpha = 2$ ,  $\beta = 10$ , and  $\gamma = 8$  in (7.2.29),

$$p(n) = 2n(n-1) + 10n + 8 = 2(n+2)^2.$$

Therefore

$$a_{n+2} = -2 \frac{(n+2)^2}{(n+2)(n+1)} a_n = -2 \frac{n+2}{n+1} a_n, \quad n \geq 0.$$

Writing this equation separately for  $n = 2m$  and  $n = 2m + 1$  yields

$$a_{2m+2} = -2 \frac{(2m+2)}{2m+1} a_{2m} = -4 \frac{m+1}{2m+1} a_{2m}, \quad m \geq 0 \quad (7.2.30)$$

and

$$a_{2m+3} = -2 \frac{2m+3}{2m+2} a_{2m+1} = -\frac{2m+3}{m+1} a_{2m+1}, \quad m \geq 0. \quad (7.2.31)$$

Starting with  $a_0 = y(0) = 2$ , we compute  $a_2, a_4$ , and  $a_6$  from (7.2.30):

$$\begin{aligned} a_2 &= -4 \frac{1}{1} 2 = -8, \\ a_4 &= -4 \frac{2}{3} (-8) = \frac{64}{3}, \\ a_6 &= -4 \frac{3}{5} \left( \frac{64}{3} \right) = -\frac{256}{5}. \end{aligned}$$

Starting with  $a_1 = y'(0) = -3$ , we compute  $a_3, a_5$  and  $a_7$  from (7.2.31):

$$\begin{aligned} a_3 &= -\frac{3}{1} (-3) = 9, \\ a_5 &= -\frac{5}{2} 9 = -\frac{45}{2}, \\ a_7 &= -\frac{7}{3} \left( -\frac{45}{2} \right) = \frac{105}{2}. \end{aligned}$$

Therefore the solution of (7.2.29) is

$$y = 2 - 3x - 8x^2 + 9x^3 + \frac{64}{3}x^4 - \frac{45}{2}x^5 - \frac{256}{5}x^6 + \frac{105}{2}x^7 + \dots$$

**USING TECHNOLOGY**

Computing coefficients recursively as in Example 7.2.4 is tedious. We recommend that you do this kind of computation by writing a short program to implement the appropriate recurrence relation on a calculator or computer. You may wish to do this in verifying examples and doing exercises (identified by the symbol **C**) in this chapter that call for numerical computation of the coefficients in series solutions. We obtained the answers to these exercises by using software that can produce answers in the form of rational numbers. However, it's perfectly acceptable - and more practical - to get your answers in decimal form. You can always check them by converting our fractions to decimals.

If you're interested in actually using series to compute numerical approximations to solutions of a differential equation, then whether or not there's a simple closed form for the coefficients is essentially irrelevant. For computational purposes it's usually more efficient to start with the given coefficients  $a_0 = y(x_0)$  and  $a_1 = y'(x_0)$ , compute  $a_2, \dots, a_N$  recursively, and then compute approximate values of the solution from the Taylor polynomial

$$T_N(x) = \sum_{n=0}^N a_n(x - x_0)^n.$$

The trick is to decide how to choose  $N$  so the approximation  $y(x) \approx T_N(x)$  is sufficiently accurate on the subinterval of the interval of convergence that you're interested in. In the computational exercises in this and the next two sections, you will often be asked to obtain the solution of a given problem by numerical integration with software of your choice (see Section 10.1 for a brief discussion of one such method), and to compare the solution obtained in this way with the approximations obtained with  $T_N$  for various values of  $N$ . This is a typical textbook kind of exercise, designed to give you insight into how the accuracy of the approximation  $y(x) \approx T_N(x)$  behaves as a function of  $N$  and the interval that you're working on. In real life, you would choose one or the other of the two methods (numerical integration or series solution). If you choose the method of series solution, then a practical procedure for determining a suitable value of  $N$  is to continue increasing  $N$  until the maximum of  $|T_N - T_{N-1}|$  on the interval of interest is within the margin of error that you're willing to accept.

In doing computational problems that call for numerical solution of differential equations you should choose the most accurate numerical integration procedure your software supports, and experiment with the step size until you're confident that the numerical results are sufficiently accurate for the problem at hand.

**7.2 Exercises**

In Exercises 1–8 find the power series in  $x$  for the general solution.

- |                                    |   |
|------------------------------------|---|
| 1. $(1 + x^2)y'' + 6xy' + 6y = 0$  | 2. $(1 + x^2)y'' + 2xy' - 2y = 0$           |
| 3. $(1 + x^2)y'' - 8xy' + 20y = 0$ | 4. $(1 - x^2)y'' - 8xy' - 12y = 0$          |
| 5. $(1 + 2x^2)y'' + 7xy' + 2y = 0$ | 6. $(1 + x^2)y'' + 2xy' + \frac{1}{4}y = 0$ |
| 7. $(1 - x^2)y'' - 5xy' - 4y = 0$  | 8. $(1 + x^2)y'' - 10xy' + 28y = 0$         |

9. **L**

- (a) Find the power series in  $x$  for the general solution of  $y'' + xy' + 2y = 0$ .  
 (b) For several choices of  $a_0$  and  $a_1$ , use differential equations software to solve the initial value problem

$$y'' + xy' + 2y = 0, \quad y(0) = a_0, \quad y'(0) = a_1, \quad (\text{A})$$

numerically on  $(-5, 5)$ .

- (c) For fixed  $r$  in  $\{1, 2, 3, 4, 5\}$  graph

$$T_N(x) = \sum_{n=0}^N a_n x^n$$

and the solution obtained in (a) on  $(-r, r)$ . Continue increasing  $N$  until there's no perceptible difference between the two graphs.

10. **L** Follow the directions of Exercise 9 for the differential equation

$$y'' + 2xy' + 3y = 0.$$

In Exercises 11–13 find  $a_0, \dots, a_N$  for  $N$  at least 7 in the power series solution  $y = \sum_{n=0}^{\infty} a_n x^n$  of the initial value problem.

11. **C**  $(1 + x^2)y'' + xy' + y = 0, \quad y(0) = 2, \quad y'(0) = -1$ 12. **C**  $(1 + 2x^2)y'' - 9xy' - 6y = 0, \quad y(0) = 1, \quad y'(0) = -1$ 13. **C**  $(1 + 8x^2)y'' + 2y = 0, \quad y(0) = 2, \quad y'(0) = -1$ 14. **L** Do the next experiment for various choices of real numbers  $a_0, a_1$ , and  $r$ , with  $0 < r < 1/\sqrt{2}$ .

- (a) Use differential equations software to solve the initial value problem

$$(1 - 2x^2)y'' - xy' + 3y = 0, \quad y(0) = a_0, \quad y'(0) = a_1, \quad (\text{A})$$

numerically on  $(-r, r)$ .

- (b) For  $N = 2, 3, 4, \dots$ , compute  $a_2, \dots, a_N$  in the power series solution  $y = \sum_{n=0}^{\infty} a_n x^n$  of (A), and graph

$$T_N(x) = \sum_{n=0}^N a_n x^n$$

and the solution obtained in (a) on  $(-r, r)$ . Continue increasing  $N$  until there's no perceptible difference between the two graphs.

15. **L** Do (a) and (b) for several values of  $r$  in  $(0, 1)$ :

- (a) Use differential equations software to solve the initial value problem

$$(1 + x^2)y'' + 10xy' + 14y = 0, \quad y(0) = 5, \quad y'(0) = 1, \quad (\text{A})$$

numerically on  $(-r, r)$ .

- (b) For  $N = 2, 3, 4, \dots$ , compute  $a_2, \dots, a_N$  in the power series solution  $y = \sum_{n=0}^{\infty} a_n x^n$  of (A), and graph

$$T_N(x) = \sum_{n=0}^N a_n x^n$$

and the solution obtained in (a) on  $(-r, r)$ . Continue increasing  $N$  until there's no perceptible difference between the two graphs. What happens to the required  $N$  as  $r \rightarrow 1$ ?

- (c) Try (a) and (b) with  $r = 1.2$ . Explain your results.



In Exercises 16–20 find the power series in  $x - x_0$  for the general solution.

16.  $y'' - y = 0; \quad x_0 = 3$     17.  $y'' - (x-3)y' - y = 0; \quad x_0 = 3$

18.  $(1 - 4x + 2x^2)y'' + 10(x - 1)y' + 6y = 0; \quad x_0 = 1$

19.  $(11 - 8x + 2x^2)y'' - 16(x - 2)y' + 36y = 0; \quad x_0 = 2$

20.  $(5 + 6x + 3x^2)y'' + 9(x + 1)y' + 3y = 0; \quad x_0 = -1$

In Exercises 21–26 find  $a_0, \dots, a_N$  for  $N$  at least 7 in the power series  $y = \sum_{n=0}^{\infty} a_n(x - x_0)^n$  for the solution of the initial value problem. Take  $x_0$  to be the point where the initial conditions are imposed.

21.  $\boxed{C} \quad (x^2 - 4)y'' - xy' - 3y = 0, \quad y(0) = -1, \quad y'(0) = 2$

22.  $\boxed{C} \quad y'' + (x - 3)y' + 3y = 0, \quad y(3) = -2, \quad y'(3) = 3$

23.  $\boxed{C} \quad (5 - 6x + 3x^2)y'' + (x - 1)y' + 12y = 0, \quad y(1) = -1, \quad y'(1) = 1$

24.  $\boxed{C} \quad (4x^2 - 24x + 37)y'' + y = 0, \quad y(3) = 4, \quad y'(3) = -6$

25.  $\boxed{C} \quad (x^2 - 8x + 14)y'' - 8(x - 4)y' + 20y = 0, \quad y(4) = 3, \quad y'(4) = -4$

26.  $\boxed{C} \quad (2x^2 + 4x + 5)y'' - 20(x + 1)y' + 60y = 0, \quad y(-1) = 3, \quad y'(-1) = -3$

27. (a) Find a power series in  $x$  for the general solution of

$$(1 + x^2)y'' + 4xy' + 2y = 0. \quad (\text{A})$$

(b) Use (a) and the formula

$$\frac{1}{1-r} = 1 + r + r^2 + \cdots + r^n + \cdots \quad (-1 < r < 1)$$

for the sum of a geometric series to find a closed form expression for the general solution of (A) on  $(-1, 1)$ .

(c) Show that the expression obtained in (b) is actually the general solution of (A) on  $(-\infty, \infty)$ .

28. Use Theorem 7.2.2 to show that the power series in  $x$  for the general solution of

$$(1 + \alpha x^2)y'' + \beta xy' + \gamma y = 0$$

is

$$y = a_0 \sum_{m=0}^{\infty} (-1)^m \left[ \prod_{j=0}^{m-1} p(2j) \right] \frac{x^{2m}}{(2m)!} + a_1 \sum_{m=0}^{\infty} (-1)^m \left[ \prod_{j=0}^{m-1} p(2j+1) \right] \frac{x^{2m+1}}{(2m+1)!}.$$

29. Use Exercise 28 to show that all solutions of

$$(1 + \alpha x^2)y'' + \beta xy' + \gamma y = 0$$

are polynomials if and only if

$$\alpha n(n-1) + \beta n + \gamma = \alpha(n-2r)(n-2s-1),$$

where  $r$  and  $s$  are nonnegative integers.

30. (a) Use Exercise 28 to show that the power series in  $x$  for the general solution of

$$(1 - x^2)y'' - 2bxy' + \alpha(\alpha + 2b - 1)y = 0$$

is  $y = a_0y_1 + a_1y_2$ , where

$$y_1 = \sum_{m=0}^{\infty} \left[ \prod_{j=0}^{m-1} (2j - \alpha)(2j + \alpha + 2b - 1) \right] \frac{x^{2m}}{(2m)!}$$

and

$$y_2 = \sum_{m=0}^{\infty} \left[ \prod_{j=0}^{m-1} (2j + 1 - \alpha)(2j + \alpha + 2b) \right] \frac{x^{2m+1}}{(2m + 1)!}.$$

- (b) Suppose  $2b$  isn't a negative odd integer and  $k$  is a nonnegative integer. Show that  $y_1$  is a polynomial of degree  $2k$  such that  $y_1(-x) = y_1(x)$  if  $\alpha = 2k$ , while  $y_2$  is a polynomial of degree  $2k+1$  such that  $y_2(-x) = -y_2(x)$  if  $\alpha = 2k+1$ . Conclude that if  $n$  is a nonnegative integer, then there's a polynomial  $P_n$  of degree  $n$  such that  $P_n(-x) = (-1)^n P_n(x)$  and

$$(1 - x^2)P_n'' - 2bP_n' + n(n + 2b - 1)P_n = 0. \quad (\text{A})$$

- (c) Show that (A) implies that

$$[(1 - x^2)^b P_n']' = -n(n + 2b - 1)(1 - x^2)^{b-1} P_n,$$

and use this to show that if  $m$  and  $n$  are nonnegative integers, then

$$\begin{aligned} & [(1 - x^2)^b P_n']' P_m - [(1 - x^2)^b P_m']' P_n = \\ & [m(m + 2b - 1) - n(n + 2b - 1)] (1 - x^2)^{b-1} P_m P_n. \end{aligned} \quad (\text{B})$$

- (d) Now suppose  $b > 0$ . Use (B) and integration by parts to show that if  $m \neq n$ , then

$$\int_{-1}^1 (1 - x^2)^{b-1} P_m(x) P_n(x) dx = 0.$$

(We say that  $P_m$  and  $P_n$  are *orthogonal on*  $(-1, 1)$  *with respect to the weighting function*  $(1 - x^2)^{b-1}$ .)

31. (a) Use Exercise 28 to show that the power series in  $x$  for the general solution of Hermite's equation

$$y'' - 2xy' + 2\alpha y = 0$$

is  $y = a_0y_1 + a_1y_2$ , where

$$y_1 = \sum_{m=0}^{\infty} \left[ \prod_{j=0}^{m-1} (2j - \alpha) \right] \frac{2^m x^{2m}}{(2m)!}$$

and

$$y_2 = \sum_{m=0}^{\infty} \left[ \prod_{j=0}^{m-1} (2j + 1 - \alpha) \right] \frac{2^m x^{2m+1}}{(2m + 1)!}.$$

- (b) Suppose  $k$  is a nonnegative integer. Show that  $y_1$  is a polynomial of degree  $2k$  such that  $y_1(-x) = y_1(x)$  if  $\alpha = 2k$ , while  $y_2$  is a polynomial of degree  $2k + 1$  such that  $y_2(-x) = -y_2(x)$  if  $\alpha = 2k + 1$ . Conclude that if  $n$  is a nonnegative integer then there's a polynomial  $P_n$  of degree  $n$  such that  $P_n(-x) = (-1)^n P_n(x)$  and

$$P_n'' - 2xP_n' + 2nP_n = 0. \quad (\text{A})$$

- (c) Show that (A) implies that

$$[e^{-x^2} P_n']' = -2ne^{-x^2} P_n,$$

and use this to show that if  $m$  and  $n$  are nonnegative integers, then

$$[e^{-x^2} P_n']' P_m - [e^{-x^2} P_m']' P_n = 2(m - n)e^{-x^2} P_m P_n. \quad (\text{B})$$

- (d) Use (B) and integration by parts to show that if  $m \neq n$ , then

$$\int_{-\infty}^{\infty} e^{-x^2} P_m(x) P_n(x) dx = 0.$$

(We say that  $P_m$  and  $P_n$  are *orthogonal on*  $(-\infty, \infty)$  *with respect to the weighting function*  $e^{-x^2}$ .)

32. Consider the equation

$$(1 + \alpha x^3) y'' + \beta x^2 y' + \gamma xy = 0, \quad (\text{A})$$

and let  $p(n) = \alpha n(n - 1) + \beta n + \gamma$ . (The special case  $y'' - xy = 0$  of (A) is Airy's equation.)

- (a) Modify the argument used to prove Theorem 7.2.2 to show that

$$y = \sum_{n=0}^{\infty} a_n x^n$$

is a solution of (A) if and only if  $a_2 = 0$  and

$$a_{n+3} = -\frac{p(n)}{(n+3)(n+2)} a_n, \quad n \geq 0.$$

- (b) Show from (a) that  $a_n = 0$  unless  $n = 3m$  or  $n = 3m + 1$  for some nonnegative integer  $m$ , and that

$$a_{3m+3} = -\frac{p(3m)}{(3m+3)(3m+2)} a_{3m}, \quad m \geq 0,$$

and

$$a_{3m+4} = -\frac{p(3m+1)}{(3m+4)(3m+3)} a_{3m+1}, \quad m \geq 0,$$

where  $a_0$  and  $a_1$  may be specified arbitrarily.

- (c) Conclude from (b) that the power series in  $x$  for the general solution of (A) is

$$y = a_0 \sum_{m=0}^{\infty} (-1)^m \left[ \prod_{j=0}^{m-1} \frac{p(3j)}{3j+2} \right] \frac{x^{3m}}{3^m m!} \\ + a_1 \sum_{m=0}^{\infty} (-1)^m \left[ \prod_{j=0}^{m-1} \frac{p(3j+1)}{3j+4} \right] \frac{x^{3m+1}}{3^m m!}.$$

In Exercises 33–37 use the method of Exercise 32 to find the power series in  $x$  for the general solution.

33.  $y'' - xy = 0$       34.  $(1 - 2x^3)y'' - 10x^2y' - 8xy = 0$   
 35.  $(1 + x^3)y'' + 7x^2y' + 9xy = 0$       36.  $(1 - 2x^3)y'' + 6x^2y' + 24xy = 0$   
 37.  $(1 - x^3)y'' + 15x^2y' - 63xy = 0$

38. Consider the equation

$$(1 + \alpha x^{k+2})y'' + \beta x^{k+1}y' + \gamma x^k y = 0, \quad (\text{A})$$

where  $k$  is a positive integer, and let  $p(n) = \alpha n(n-1) + \beta n + \gamma$ .

(a) Modify the argument used to prove Theorem 7.2.2 to show that

$$y = \sum_{n=0}^{\infty} a_n x^n$$

is a solution of (A) if and only if  $a_n = 0$  for  $2 \leq n \leq k+1$  and

$$a_{n+k+2} = -\frac{p(n)}{(n+k+2)(n+k+1)} a_n, \quad n \geq 0.$$

(b) Show from (a) that  $a_n = 0$  unless  $n = (k+2)m$  or  $n = (k+2)m+1$  for some nonnegative integer  $m$ , and that

$$a_{(k+2)(m+1)} = -\frac{p((k+2)m)}{(k+2)(m+1)[(k+2)(m+1)-1]} a_{(k+2)m}, \quad m \geq 0,$$

and

$$a_{(k+2)(m+1)+1} = -\frac{p((k+2)m+1)}{[(k+2)(m+1)+1](k+2)(m+1)} a_{(k+2)m+1}, \quad m \geq 0,$$

where  $a_0$  and  $a_1$  may be specified arbitrarily.

(c) Conclude from (b) that the power series in  $x$  for the general solution of (A) is

$$y = a_0 \sum_{m=0}^{\infty} (-1)^m \left[ \prod_{j=0}^{m-1} \frac{p((k+2)j)}{(k+2)(j+1)-1} \right] \frac{x^{(k+2)m}}{(k+2)^m m!} \\ + a_1 \sum_{m=0}^{\infty} (-1)^m \left[ \prod_{j=0}^{m-1} \frac{p((k+2)j+1)}{(k+2)(j+1)+1} \right] \frac{x^{(k+2)m+1}}{(k+2)^m m!}.$$

In Exercises 39–44 use the method of Exercise 38 to find the power series in  $x$  for the general solution.

39.  $(1 + 2x^5)y'' + 14x^4y' + 10x^3y = 0$   
 40.  $y'' + x^2y = 0$       41.  $y'' + x^6y' + 7x^5y = 0$   
 42.  $(1 + x^8)y'' - 16x^7y' + 72x^6y = 0$   
 43.  $(1 - x^6)y'' - 12x^5y' - 30x^4y = 0$   
 44.  $y'' + x^5y' + 6x^4y = 0$

### 7.3 SERIES SOLUTIONS NEAR AN ORDINARY POINT II

In this section we continue to find series solutions

$$y = \sum_{n=0}^{\infty} a_n(x - x_0)^n$$

of initial value problems

$$P_0(x)y'' + P_1(x)y' + P_2(x)y = 0, \quad y(x_0) = a_0, \quad y'(x_0) = a_1, \quad (7.3.1)$$

where  $P_0, P_1,$  and  $P_2$  are polynomials and  $P_0(x_0) \neq 0$ , so  $x_0$  is an ordinary point of (7.3.1). However, here we consider cases where the differential equation in (7.3.1) is not of the form

$$(1 + \alpha(x - x_0)^2)y'' + \beta(x - x_0)y' + \gamma y = 0,$$

so Theorem 7.2.2 does not apply, and the computation of the coefficients  $\{a_n\}$  is more complicated. For the equations considered here it's difficult or impossible to obtain an explicit formula for  $a_n$  in terms of  $n$ . Nevertheless, we can calculate as many coefficients as we wish. The next three examples illustrate this.

**Example 7.3.1** Find the coefficients  $a_0, \dots, a_7$  in the series solution  $y = \sum_{n=0}^{\infty} a_n x^n$  of the initial value problem

$$(1 + x + 2x^2)y'' + (1 + 7x)y' + 2y = 0, \quad y(0) = -1, \quad y'(0) = -2. \quad (7.3.2)$$

**Solution** Here

$$Ly = (1 + x + 2x^2)y'' + (1 + 7x)y' + 2y.$$

The zeros  $(-1 \pm i\sqrt{7})/4$  of  $P_0(x) = 1 + x + 2x^2$  have absolute value  $1/\sqrt{2}$ , so Theorem 7.2.2 implies that the series solution converges to the solution of (7.3.2) on  $(-1/\sqrt{2}, 1/\sqrt{2})$ . Since

$$y = \sum_{n=0}^{\infty} a_n x^n, \quad y' = \sum_{n=1}^{\infty} n a_n x^{n-1} \quad \text{and} \quad y'' = \sum_{n=2}^{\infty} n(n-1) a_n x^{n-2},$$

$$\begin{aligned} Ly &= \sum_{n=2}^{\infty} n(n-1) a_n x^{n-2} + \sum_{n=2}^{\infty} n(n-1) a_n x^{n-1} + 2 \sum_{n=2}^{\infty} n(n-1) a_n x^n \\ &\quad + \sum_{n=1}^{\infty} n a_n x^{n-1} + 7 \sum_{n=1}^{\infty} n a_n x^n + 2 \sum_{n=0}^{\infty} a_n x^n. \end{aligned}$$

Shifting indices so the general term in each series is a constant multiple of  $x^n$  yields

$$\begin{aligned} Ly &= \sum_{n=0}^{\infty} (n+2)(n+1) a_{n+2} x^n + \sum_{n=0}^{\infty} (n+1) n a_{n+1} x^n + 2 \sum_{n=0}^{\infty} n(n-1) a_n x^n \\ &\quad + \sum_{n=0}^{\infty} (n+1) a_{n+1} x^n + 7 \sum_{n=0}^{\infty} n a_n x^n + 2 \sum_{n=0}^{\infty} a_n x^n = \sum_{n=0}^{\infty} b_n x^n, \end{aligned}$$

where

$$b_n = (n+2)(n+1)a_{n+2} + (n+1)^2 a_{n+1} + (n+2)(2n+1)a_n.$$

Therefore  $y = \sum_{n=0}^{\infty} a_n x^n$  is a solution of  $Ly = 0$  if and only if

$$a_{n+2} = -\frac{n+1}{n+2} a_{n+1} - \frac{2n+1}{n+1} a_n, \quad n \geq 0. \quad (7.3.3)$$

From the initial conditions in (7.3.2),  $a_0 = y(0) = -1$  and  $a_1 = y'(0) = -2$ . Setting  $n = 0$  in (7.3.3) yields

$$a_2 = -\frac{1}{2} a_1 - a_0 = -\frac{1}{2}(-2) - (-1) = 2.$$

Setting  $n = 1$  in (7.3.3) yields

$$a_3 = -\frac{2}{3} a_2 - \frac{3}{2} a_1 = -\frac{2}{3}(2) - \frac{3}{2}(-2) = \frac{5}{3}.$$

We leave it to you to compute  $a_4, a_5, a_6, a_7$  from (7.3.3) and show that

$$y = -1 - 2x + 2x^2 + \frac{5}{3}x^3 - \frac{55}{12}x^4 + \frac{3}{4}x^5 + \frac{61}{8}x^6 - \frac{443}{56}x^7 + \dots$$

We also leave it to you (Exercise 13) to verify numerically that the Taylor polynomials  $T_N(x) = \sum_{n=0}^N a_n x^n$  converge to the solution of (7.3.2) on  $(-1/\sqrt{2}, 1/\sqrt{2})$ .

**Example 7.3.2** Find the coefficients  $a_0, \dots, a_5$  in the series solution

$$y = \sum_{n=0}^{\infty} a_n (x+1)^n$$

of the initial value problem

$$(3+x)y'' + (1+2x)y' - (2-x)y = 0, \quad y(-1) = 2, \quad y'(-1) = -3. \quad (7.3.4)$$

**Solution** Since the desired series is in powers of  $x+1$  we rewrite the differential equation in (7.3.4) as  $Ly = 0$ , with

$$Ly = (2+(x+1))y'' - (1-2(x+1))y' - (3-(x+1))y.$$

Since

$$y = \sum_{n=0}^{\infty} a_n (x+1)^n, \quad y' = \sum_{n=1}^{\infty} n a_n (x+1)^{n-1} \quad \text{and} \quad y'' = \sum_{n=2}^{\infty} n(n-1) a_n (x+1)^{n-2},$$

$$\begin{aligned} Ly &= 2 \sum_{n=2}^{\infty} n(n-1) a_n (x+1)^{n-2} + \sum_{n=2}^{\infty} n(n-1) a_n (x+1)^{n-1} \\ &\quad - \sum_{n=1}^{\infty} n a_n (x+1)^{n-1} + 2 \sum_{n=1}^{\infty} n a_n (x+1)^n \\ &\quad - 3 \sum_{n=0}^{\infty} a_n (x+1)^n + \sum_{n=0}^{\infty} a_n (x+1)^{n+1}. \end{aligned}$$

Shifting indices so that the general term in each series is a constant multiple of  $(x + 1)^n$  yields

$$\begin{aligned} Ly &= 2 \sum_{n=0}^{\infty} (n+2)(n+1)a_{n+2}(x+1)^n + \sum_{n=0}^{\infty} (n+1)na_{n+1}(x+1)^n \\ &\quad - \sum_{n=0}^{\infty} (n+1)a_{n+1}(x+1)^n + \sum_{n=0}^{\infty} (2n-3)a_n(x+1)^n + \sum_{n=1}^{\infty} a_{n-1}(x+1)^n \\ &= \sum_{n=0}^{\infty} b_n(x+1)^n, \end{aligned}$$

where

$$b_0 = 4a_2 - a_1 - 3a_0$$

and

$$b_n = 2(n+2)(n+1)a_{n+2} + (n^2 - 1)a_{n+1} + (2n - 3)a_n + a_{n-1}, \quad n \geq 1.$$

Therefore  $y = \sum_{n=0}^{\infty} a_n(x+1)^n$  is a solution of  $Ly = 0$  if and only if

$$a_2 = \frac{1}{4}(a_1 + 3a_0) \quad (7.3.5)$$

and

$$a_{n+2} = -\frac{1}{2(n+2)(n+1)} [(n^2 - 1)a_{n+1} + (2n - 3)a_n + a_{n-1}], \quad n \geq 1. \quad (7.3.6)$$

From the initial conditions in (7.3.4),  $a_0 = y(-1) = 2$  and  $a_1 = y'(-1) = -3$ . We leave it to you to compute  $a_2, \dots, a_5$  with (7.3.5) and (7.3.6) and show that the solution of (7.3.4) is

$$y = -2 - 3(x+1) + \frac{3}{4}(x+1)^2 - \frac{5}{12}(x+1)^3 + \frac{7}{48}(x+1)^4 - \frac{1}{60}(x+1)^5 + \dots$$

We also leave it to you (Exercise 14) to verify numerically that the Taylor polynomials  $T_N(x) = \sum_{n=0}^N a_n x^n$  converge to the solution of (7.3.4) on the interval of convergence of the power series solution.

**Example 7.3.3** Find the coefficients  $a_0, \dots, a_5$  in the series solution  $y = \sum_{n=0}^{\infty} a_n x^n$  of the initial value problem

$$y'' + 3xy' + (4 + 2x^2)y = 0, \quad y(0) = 2, \quad y'(0) = -3. \quad (7.3.7)$$

**Solution** Here

$$Ly = y'' + 3xy' + (4 + 2x^2)y.$$

Since

$$y = \sum_{n=0}^{\infty} a_n x^n, \quad y' = \sum_{n=1}^{\infty} n a_n x^{n-1}, \quad \text{and} \quad y'' = \sum_{n=2}^{\infty} n(n-1) a_n x^{n-2},$$

$$Ly = \sum_{n=2}^{\infty} n(n-1) a_n x^{n-2} + 3 \sum_{n=1}^{\infty} n a_n x^n + 4 \sum_{n=0}^{\infty} a_n x^n + 2 \sum_{n=0}^{\infty} a_n x^{n+2}.$$

Shifting indices so that the general term in each series is a constant multiple of  $x^n$  yields

$$Ly = \sum_{n=0}^{\infty} (n+2)(n+1)a_{n+2}x^n + \sum_{n=0}^{\infty} (3n+4)a_n x^n + 2 \sum_{n=2}^{\infty} a_{n-2}x^n = \sum_{n=0}^{\infty} b_n x^n$$

where

$$b_0 = 2a_2 + 4a_0, \quad b_1 = 6a_3 + 7a_1,$$

and

$$b_n = (n+2)(n+1)a_{n+2} + (3n+4)a_n + 2a_{n-2}, \quad n \geq 2.$$

Therefore  $y = \sum_{n=0}^{\infty} a_n x^n$  is a solution of  $Ly = 0$  if and only if

$$a_2 = -2a_0, \quad a_3 = -\frac{7}{6}a_1, \quad (7.3.8)$$

and

$$a_{n+2} = -\frac{1}{(n+2)(n+1)} [(3n+4)a_n + 2a_{n-2}], \quad n \geq 2. \quad (7.3.9)$$

From the initial conditions in (7.3.7),  $a_0 = y(0) = 2$  and  $a_1 = y'(0) = -3$ . We leave it to you to compute  $a_2, \dots, a_5$  with (7.3.8) and (7.3.9) and show that the solution of (7.3.7) is

$$y = 2 - 3x - 4x^2 + \frac{7}{2}x^3 + 3x^4 - \frac{79}{40}x^5 + \dots$$

We also leave it to you (Exercise 15) to verify numerically that the Taylor polynomials  $T_N(x) = \sum_{n=0}^N a_n x^n$  converge to the solution of (7.3.9) on the interval of convergence of the power series solution.

### 7.3 Exercises

In Exercises 1–12 find the coefficients  $a_0, \dots, a_N$  for  $N$  at least 7 in the series solution  $y = \sum_{n=0}^{\infty} a_n x^n$  of the initial value problem.

1.  C  $(1 + 3x)y'' + xy' + 2y = 0, \quad y(0) = 2, \quad y'(0) = -3$
2.  C  $(1 + x + 2x^2)y'' + (2 + 8x)y' + 4y = 0, \quad y(0) = -1, \quad y'(0) = 2$
3.  C  $(1 - 2x^2)y'' + (2 - 6x)y' - 2y = 0, \quad y(0) = 1, \quad y'(0) = 0$
4.  C  $(1 + x + 3x^2)y'' + (2 + 15x)y' + 12y = 0, \quad y(0) = 0, \quad y'(0) = 1$
5.  C  $(2 + x)y'' + (1 + x)y' + 3y = 0, \quad y(0) = 4, \quad y'(0) = 3$
6.  C  $(3 + 3x + x^2)y'' + (6 + 4x)y' + 2y = 0, \quad y(0) = 7, \quad y'(0) = 3$
7.  C  $(4 + x)y'' + (2 + x)y' + 2y = 0, \quad y(0) = 2, \quad y'(0) = 5$
8.  C  $(2 - 3x + 2x^2)y'' - (4 - 6x)y' + 2y = 0, \quad y(1) = 1, \quad y'(1) = -1$
9.  C  $(3x + 2x^2)y'' + 10(1 + x)y' + 8y = 0, \quad y(-1) = 1, \quad y'(-1) = -1$
10.  C  $(1 - x + x^2)y'' - (1 - 4x)y' + 2y = 0, \quad y(1) = 2, \quad y'(1) = -1$
11.  C  $(2 + x)y'' + (2 + x)y' + y = 0, \quad y(-1) = -2, \quad y'(-1) = 3$
12.  C  $x^2y'' - (6 - 7x)y' + 8y = 0, \quad y(1) = 1, \quad y'(1) = -2$
13.  L Do the following experiment for various choices of real numbers  $a_0, a_1$ , and  $r$ , with  $0 < r < 1/\sqrt{2}$ .



- (a) Use differential equations software to solve the initial value problem

$$(1 + x + 2x^2)y'' + (1 + 7x)y' + 2y = 0, \quad y(0) = a_0, \quad y'(0) = a_1, \quad (\text{A})$$

numerically on  $(-r, r)$ . (See Example 7.3.1.)

- (b) For  $N = 2, 3, 4, \dots$ , compute  $a_2, \dots, a_N$  in the power series solution  $y = \sum_{n=0}^{\infty} a_n x^n$  of (A), and graph

$$T_N(x) = \sum_{n=0}^N a_n x^n$$

and the solution obtained in (a) on  $(-r, r)$ . Continue increasing  $N$  until there's no perceptible difference between the two graphs.

14. **L** Do the following experiment for various choices of real numbers  $a_0, a_1$ , and  $r$ , with  $0 < r < 2$ .

- (a) Use differential equations software to solve the initial value problem

$$(3 + x)y'' + (1 + 2x)y' - (2 - x)y = 0, \quad y(-1) = a_0, \quad y'(-1) = a_1, \quad (\text{A})$$

numerically on  $(-1 - r, -1 + r)$ . (See Example 7.3.2. Why this interval?)

- (b) For  $N = 2, 3, 4, \dots$ , compute  $a_2, \dots, a_N$  in the power series solution

$$y = \sum_{n=0}^{\infty} a_n (x + 1)^n$$

of (A), and graph

$$T_N(x) = \sum_{n=0}^N a_n (x + 1)^n$$

and the solution obtained in (a) on  $(-1 - r, -1 + r)$ . Continue increasing  $N$  until there's no perceptible difference between the two graphs.

15. **L** Do the following experiment for several choices of  $a_0, a_1$ , and  $r$ , with  $r > 0$ .

- (a) Use differential equations software to solve the initial value problem

$$y'' + 3xy' + (4 + 2x^2)y = 0, \quad y(0) = a_0, \quad y'(0) = a_1, \quad (\text{A})$$

numerically on  $(-r, r)$ . (See Example 7.3.3.)

- (b) Find the coefficients  $a_0, a_1, \dots, a_N$  in the power series solution  $y = \sum_{n=0}^{\infty} a_n x^n$  of (A), and graph

$$T_N(x) = \sum_{n=0}^N a_n x^n$$

and the solution obtained in (a) on  $(-r, r)$ . Continue increasing  $N$  until there's no perceptible difference between the two graphs.

16. **L** Do the following experiment for several choices of  $a_0$  and  $a_1$ .

(a) Use differential equations software to solve the initial value problem

$$(1-x)y'' - (2-x)y' + y = 0, \quad y(0) = a_0, \quad y'(0) = a_1, \quad (\text{A})$$

numerically on  $(-r, r)$ .

(b) Find the coefficients  $a_0, a_1, \dots, a_N$  in the power series solution  $y = \sum_{n=0}^N a_n x^n$  of (A), and graph

$$T_N(x) = \sum_{n=0}^N a_n x^n$$

and the solution obtained in (a) on  $(-r, r)$ . Continue increasing  $N$  until there's no perceptible difference between the two graphs. What happens as you let  $r \rightarrow 1$ ?

17. **L** Follow the directions of Exercise 16 for the initial value problem

$$(1+x)y'' + 3y' + 32y = 0, \quad y(0) = a_0, \quad y'(0) = a_1.$$

18. **L** Follow the directions of Exercise 16 for the initial value problem

$$(1+x^2)y'' + y' + 2y = 0, \quad y(0) = a_0, \quad y'(0) = a_1.$$

In Exercises 19–28 find the coefficients  $a_0, \dots, a_N$  for  $N$  at least 7 in the series solution

$$y = \sum_{n=0}^{\infty} a_n (x - x_0)^n$$

of the initial value problem. Take  $x_0$  to be the point where the initial conditions are imposed.

19. **C**  $(2+4x)y'' - 4y' - (6+4x)y = 0, \quad y(0) = 2, \quad y'(0) = -7$

20. **C**  $(1+2x)y'' - (1-2x)y' - (3-2x)y = 0, \quad y(1) = 1, \quad y'(1) = -2$

21. **C**  $(5+2x)y'' - y' + (5+x)y = 0, \quad y(-2) = 2, \quad y'(-2) = -1$

22. **C**  $(4+x)y'' - (4+2x)y' + (6+x)y = 0, \quad y(-3) = 2, \quad y'(-3) = -2$

23. **C**  $(2+3x)y'' - xy' + 2xy = 0, \quad y(0) = -1, \quad y'(0) = 2$

24. **C**  $(3+2x)y'' + 3y' - xy = 0, \quad y(-1) = 2, \quad y'(-1) = -3$

25. **C**  $(3+2x)y'' - 3y' - (2+x)y = 0, \quad y(-2) = -2, \quad y'(-2) = 3$

26. **C**  $(10-2x)y'' + (1+x)y = 0, \quad y(2) = 2, \quad y'(2) = -4$

27. **C**  $(7+x)y'' + (8+2x)y' + (5+x)y = 0, \quad y(-4) = 1, \quad y'(-4) = 2$

28. **C**  $(6+4x)y'' + (1+2x)y = 0, \quad y(-1) = -1, \quad y'(-1) = 2$

29. Show that the coefficients in the power series in  $x$  for the general solution of

$$(1 + \alpha x + \beta x^2)y'' + (\gamma + \delta x)y' + \epsilon y = 0$$

satisfy the recurrence relation

$$a_{n+2} = -\frac{\gamma + \alpha n}{n+2} a_{n+1} - \frac{\beta n(n-1) + \delta n + \epsilon}{(n+2)(n+1)} a_n.$$

30. (a) Let  $\alpha$  and  $\beta$  be constants, with  $\beta \neq 0$ . Show that  $y = \sum_{n=0}^{\infty} a_n x^n$  is a solution of

$$(1 + \alpha x + \beta x^2)y'' + (2\alpha + 4\beta x)y' + 2\beta y = 0 \quad (\text{A})$$

if and only if

$$a_{n+2} + \alpha a_{n+1} + \beta a_n = 0, \quad n \geq 0. \quad (\text{B})$$

An equation of this form is called a *second order homogeneous linear difference equation*. The polynomial  $p(r) = r^2 + \alpha r + \beta$  is called the *characteristic polynomial* of (B). If  $r_1$  and  $r_2$  are the zeros of  $p$ , then  $1/r_1$  and  $1/r_2$  are the zeros of

$$P_0(x) = 1 + \alpha x + \beta x^2.$$

- (b) Suppose  $p(r) = (r - r_1)(r - r_2)$  where  $r_1$  and  $r_2$  are real and distinct, and let  $\rho$  be the smaller of the two numbers  $\{1/|r_1|, 1/|r_2|\}$ . Show that if  $c_1$  and  $c_2$  are constants then the sequence

$$a_n = c_1 r_1^n + c_2 r_2^n, \quad n \geq 0$$

satisfies (B). Conclude from this that any function of the form

$$y = \sum_{n=0}^{\infty} (c_1 r_1^n + c_2 r_2^n) x^n$$

is a solution of (A) on  $(-\rho, \rho)$ .

- (c) Use (b) and the formula for the sum of a geometric series to show that the functions

$$y_1 = \frac{1}{1 - r_1 x} \quad \text{and} \quad y_2 = \frac{1}{1 - r_2 x}$$

form a fundamental set of solutions of (A) on  $(-\rho, \rho)$ .

- (d) Show that  $\{y_1, y_2\}$  is a fundamental set of solutions of (A) on any interval that does not contain either  $1/r_1$  or  $1/r_2$ .
- (e) Suppose  $p(r) = (r - r_1)^2$ , and let  $\rho = 1/|r_1|$ . Show that if  $c_1$  and  $c_2$  are constants then the sequence

$$a_n = (c_1 + c_2 n) r_1^n, \quad n \geq 0$$

satisfies (B). Conclude from this that any function of the form

$$y = \sum_{n=0}^{\infty} (c_1 + c_2 n) r_1^n x^n$$

is a solution of (A) on  $(-\rho, \rho)$ .

- (f) Use (e) and the formula for the sum of a geometric series to show that the functions

$$y_1 = \frac{1}{1 - r_1 x} \quad \text{and} \quad y_2 = \frac{x}{(1 - r_1 x)^2}$$

form a fundamental set of solutions of (A) on  $(-\rho, \rho)$ .

- (g) Show that  $\{y_1, y_2\}$  is a fundamental set of solutions of (A) on any interval that does not contain  $1/r_1$ .

31. Use the results of Exercise 30 to find the general solution of the given equation on any interval on which polynomial multiplying  $y''$  has no zeros.

(a)  $(1 + 3x + 2x^2)y'' + (6 + 8x)y' + 4y = 0$

(b)  $(1 - 5x + 6x^2)y'' - (10 - 24x)y' + 12y = 0$

(c)  $(1 - 4x + 4x^2)y'' - (8 - 16x)y' + 8y = 0$

(d)  $(4 + 4x + x^2)y'' + (8 + 4x)y' + 2y = 0$

(e)  $(4 + 8x + 3x^2)y'' + (16 + 12x)y' + 6y = 0$

In Exercises 32–38 find the coefficients  $a_0, \dots, a_N$  for  $N$  at least 7 in the series solution  $y = \sum_{n=0}^{\infty} a_n x^n$  of the initial value problem.

32.   $y'' + 2xy' + (3 + 2x^2)y = 0, \quad y(0) = 1, \quad y'(0) = -2$

33.   $y'' - 3xy' + (5 + 2x^2)y = 0, \quad y(0) = 1, \quad y'(0) = -2$

34.   $y'' + 5xy' - (3 - x^2)y = 0, \quad y(0) = 6, \quad y'(0) = -2$

35.   $y'' - 2xy' - (2 + 3x^2)y = 0, \quad y(0) = 2, \quad y'(0) = -5$

36.   $y'' - 3xy' + (2 + 4x^2)y = 0, \quad y(0) = 3, \quad y'(0) = 6$

37.   $2y'' + 5xy' + (4 + 2x^2)y = 0, \quad y(0) = 3, \quad y'(0) = -2$

38.   $3y'' + 2xy' + (4 - x^2)y = 0, \quad y(0) = -2, \quad y'(0) = 3$

39. Find power series in  $x$  for the solutions  $y_1$  and  $y_2$  of

$$y'' + 4xy' + (2 + 4x^2)y = 0$$

such that  $y_1(0) = 1, y_1'(0) = 0, y_2(0) = 0, y_2'(0) = 1$ , and identify  $y_1$  and  $y_2$  in terms of familiar elementary functions.

In Exercises 40–49 find the coefficients  $a_0, \dots, a_N$  for  $N$  at least 7 in the series solution

$$y = \sum_{n=0}^{\infty} a_n (x - x_0)^n$$

of the initial value problem. Take  $x_0$  to be the point where the initial conditions are imposed.

40.   $(1 + x)y'' + x^2y' + (1 + 2x)y = 0, \quad y(0) = 2, \quad y'(0) = 3$

41.   $y'' + (1 + 2x + x^2)y' + 2y = 0, \quad y(0) = 2, \quad y'(0) = 3$

42.   $(1 + x^2)y'' + (2 + x^2)y' + xy = 0, \quad y(0) = -3, \quad y'(0) = 5$

43.   $(1 + x)y'' + (1 - 3x + 2x^2)y' - (x - 4)y = 0, \quad y(1) = -2, \quad y'(1) = 3$

44.   $y'' + (13 + 12x + 3x^2)y' + (5 + 2x)y = 0, \quad y(-2) = 2, \quad y'(-2) = -3$

45.   $(1 + 2x + 3x^2)y'' + (2 - x^2)y' + (1 + x)y = 0, \quad y(0) = 1, \quad y'(0) = -2$

46.   $(3 + 4x + x^2)y'' - (5 + 4x - x^2)y' - (2 + x)y = 0, \quad y(-2) = 2, \quad y'(-2) = -1$

47.   $(1 + 2x + x^2)y'' + (1 - x)y = 0, \quad y(0) = 2, \quad y'(0) = -1$

48.   $(x - 2x^2)y'' + (1 + 3x - x^2)y' + (2 + x)y = 0, \quad y(1) = 1, \quad y'(1) = 0$

49.   $(16 - 11x + 2x^2)y'' + (10 - 6x + x^2)y' - (2 - x)y, \quad y(3) = 1, \quad y'(3) = -2$

## 7.4 REGULAR SINGULAR POINTS EULER EQUATIONS

This section sets the stage for Sections 1.5, 1.6, and 1.7. If you're not interested in those sections, but wish to learn about Euler equations, omit the introductory paragraphs and start reading at Definition 7.4.2.

In the next three sections we'll continue to study equations of the form

$$P_0(x)y'' + P_1(x)y' + P_2(x)y = 0 \quad (7.4.1)$$

where  $P_0$ ,  $P_1$ , and  $P_2$  are polynomials, but the emphasis will be different from that of Sections 7.2 and 7.3, where we obtained solutions of (7.4.1) near an ordinary point  $x_0$  in the form of power series in  $x - x_0$ . If  $x_0$  is a singular point of (7.4.1) (that is, if  $P_0(x_0) = 0$ ), the solutions can't in general be represented by power series in  $x - x_0$ . Nevertheless, it's often necessary in physical applications to study the behavior of solutions of (7.4.1) near a singular point. Although this can be difficult in the absence of some sort of assumption on the nature of the singular point, equations that satisfy the requirements of the next definition can be solved by series methods discussed in the next three sections. Fortunately, many equations arising in applications satisfy these requirements.

**Definition 7.4.1** Let  $P_0$ ,  $P_1$ , and  $P_2$  be polynomials with no common factor and suppose  $P_0(x_0) = 0$ . Then  $x_0$  is a *regular singular point* of the equation

$$P_0(x)y'' + P_1(x)y' + P_2(x)y = 0 \quad (7.4.2)$$

if (7.4.2) can be written as

$$(x - x_0)^2 A(x)y'' + (x - x_0)B(x)y' + C(x)y = 0 \quad (7.4.3)$$

where  $A$ ,  $B$ , and  $C$  are polynomials and  $A(x_0) \neq 0$ ; otherwise,  $x_0$  is an *irregular* singular point of (7.4.2).

**Example 7.4.1** Bessel's equation,

$$x^2 y'' + xy' + (x^2 - \nu^2)y = 0, \quad (7.4.4)$$

has the singular point  $x_0 = 0$ . Since this equation is of the form (7.4.3) with  $x_0 = 0$ ,  $A(x) = 1$ ,  $B(x) = 1$ , and  $C(x) = x^2 - \nu^2$ , it follows that  $x_0 = 0$  is a regular singular point of (7.4.4).

**Example 7.4.2** Legendre's equation,

$$(1 - x^2)y'' - 2xy' + \alpha(\alpha + 1)y = 0, \quad (7.4.5)$$

has the singular points  $x_0 = \pm 1$ . Multiplying through by  $1 - x$  yields

$$(x - 1)^2(x + 1)y'' + 2x(x - 1)y' - \alpha(\alpha + 1)(x - 1)y = 0,$$

which is of the form (7.4.3) with  $x_0 = 1$ ,  $A(x) = x + 1$ ,  $B(x) = 2x$ , and  $C(x) = -\alpha(\alpha + 1)(x - 1)$ . Therefore  $x_0 = 1$  is a regular singular point of (7.4.5). We leave it to you to show that  $x_0 = -1$  is also a regular singular point of (7.4.5).

**Example 7.4.3** The equation

$$x^3y'' + xy' + y = 0$$

has an irregular singular point at  $x_0 = 0$ . (Verify.)

For convenience we restrict our attention to the case where  $x_0 = 0$  is a regular singular point of (7.4.2). This isn't really a restriction, since if  $x_0 \neq 0$  is a regular singular point of (7.4.2) then introducing the new independent variable  $t = x - x_0$  and the new unknown  $Y(t) = y(t + x_0)$  leads to a differential equation with polynomial coefficients that has a regular singular point at  $t_0 = 0$ . This is illustrated in Exercise 22 for Legendre's equation, and in Exercise 23 for the general case.

### Euler Equations

The simplest kind of equation with a regular singular point at  $x_0 = 0$  is the Euler equation, defined as follows.

**Definition 7.4.2** An Euler equation is an equation that can be written in the form

$$ax^2y'' + bxy' + cy = 0, \quad (7.4.6)$$

where  $a, b$ , and  $c$  are real constants and  $a \neq 0$ .

Theorem 5.1.1 implies that (7.4.6) has solutions defined on  $(0, \infty)$  and  $(-\infty, 0)$ , since (7.4.6) can be rewritten as

$$ay'' + \frac{b}{x}y' + \frac{c}{x^2}y = 0.$$

For convenience we'll restrict our attention to the interval  $(0, \infty)$ . (Exercise 19 deals with solutions of (7.4.6) on  $(-\infty, 0)$ .) The key to finding solutions on  $(0, \infty)$  is that if  $x > 0$  then  $x^r$  is defined as a real-valued function on  $(0, \infty)$  for all values of  $r$ , and substituting  $y = x^r$  into (7.4.6) produces

$$\begin{aligned} ax^2(x^r)'' + bx(x^r)' + cx^r &= ax^2r(r-1)x^{r-2} + bxx^rx^{r-1} + cx^r \\ &= [ar(r-1) + br + c]x^r. \end{aligned} \quad (7.4.7)$$

The polynomial

$$p(r) = ar(r-1) + br + c$$

is called the *indicial polynomial* of (7.4.6), and  $p(r) = 0$  is its *indicial equation*. From (7.4.7) we can see that  $y = x^r$  is a solution of (7.4.6) on  $(0, \infty)$  if and only if  $p(r) = 0$ . Therefore, if the indicial equation has distinct real roots  $r_1$  and  $r_2$  then  $y_1 = x^{r_1}$  and  $y_2 = x^{r_2}$  form a fundamental set of solutions of (7.4.6) on  $(0, \infty)$ , since  $y_2/y_1 = x^{r_2-r_1}$  is nonconstant. In this case

$$y = c_1x^{r_1} + c_2x^{r_2}$$

is the general solution of (7.4.6) on  $(0, \infty)$ .

**Example 7.4.4** Find the general solution of

$$x^2y'' - xy' - 8y = 0 \quad (7.4.8)$$

on  $(0, \infty)$ .

**Solution** The indicial polynomial of (7.4.8) is

$$p(r) = r(r-1) - r - 8 = (r-4)(r+2).$$

Therefore  $y_1 = x^4$  and  $y_2 = x^{-2}$  are solutions of (7.4.8) on  $(0, \infty)$ , and its general solution on  $(0, \infty)$  is

$$y = c_1x^4 + \frac{c_2}{x^2}.$$

**Example 7.4.5** Find the general solution of

$$6x^2y'' + 5xy' - y = 0 \quad (7.4.9)$$

on  $(0, \infty)$ .

**Solution** The indicial polynomial of (7.4.9) is

$$p(r) = 6r(r - 1) + 5r - 1 = (2r - 1)(3r + 1).$$

Therefore the general solution of (7.4.9) on  $(0, \infty)$  is

$$y = c_1x^{1/2} + c_2x^{-1/3}. \blacksquare$$

If the indicial equation has a repeated root  $r_1$ , then  $y_1 = x^{r_1}$  is a solution of

$$ax^2y'' + bxy' + cy = 0, \quad (7.4.10)$$

on  $(0, \infty)$ , but (7.4.10) has no other solution of the form  $y = x^r$ . If the indicial equation has complex conjugate zeros then (7.4.10) has no real-valued solutions of the form  $y = x^r$ . Fortunately we can use the results of Section 5.2 for constant coefficient equations to solve (7.4.10) in any case.

**Theorem 7.4.3** *Suppose the roots of the indicial equation*

$$ar(r - 1) + br + c = 0 \quad (7.4.11)$$

*are  $r_1$  and  $r_2$ . Then the general solution of the Euler equation*

$$ax^2y'' + bxy' + cy = 0 \quad (7.4.12)$$

*on  $(0, \infty)$  is*

$$\begin{aligned} y &= c_1x^{r_1} + c_2x^{r_2} \text{ if } r_1 \text{ and } r_2 \text{ are distinct real numbers;} \\ y &= x^{r_1}(c_1 + c_2 \ln x) \text{ if } r_1 = r_2; \\ y &= x^\lambda [c_1 \cos(\omega \ln x) + c_2 \sin(\omega \ln x)] \text{ if } r_1, r_2 = \lambda \pm i\omega \text{ with } \omega > 0. \end{aligned}$$

**Proof** We first show that  $y = y(x)$  satisfies (7.4.12) on  $(0, \infty)$  if and only if  $Y(t) = y(e^t)$  satisfies the constant coefficient equation

$$a \frac{d^2Y}{dt^2} + (b - a) \frac{dY}{dt} + cY = 0 \quad (7.4.13)$$

on  $(-\infty, \infty)$ . To do this, it's convenient to write  $x = e^t$ , or, equivalently,  $t = \ln x$ ; thus,  $Y(t) = y(x)$ , where  $x = e^t$ . From the chain rule,

$$\frac{dY}{dt} = \frac{dy}{dx} \frac{dx}{dt}$$

and, since

$$\frac{dx}{dt} = e^t = x,$$

it follows that

$$\frac{dY}{dt} = x \frac{dy}{dx}. \quad (7.4.14)$$

Differentiating this with respect to  $t$  and using the chain rule again yields

$$\begin{aligned}\frac{d^2Y}{dt^2} &= \frac{d}{dt} \left( \frac{dY}{dt} \right) = \frac{d}{dt} \left( x \frac{dy}{dx} \right) \\ &= \frac{dx}{dt} \frac{dy}{dx} + x \frac{d^2y}{dx^2} \frac{dx}{dt} \\ &= x \frac{dy}{dx} + x^2 \frac{d^2y}{dx^2} \quad \left( \text{since } \frac{dx}{dt} = x \right).\end{aligned}$$

From this and (7.4.14),

$$x^2 \frac{d^2y}{dx^2} = \frac{d^2Y}{dt^2} - \frac{dY}{dt}.$$

Substituting this and (7.4.14) into (7.4.12) yields (7.4.13). Since (7.4.11) is the characteristic equation of (7.4.13), Theorem 5.2.1 implies that the general solution of (7.4.13) on  $(-\infty, \infty)$  is

$$\begin{aligned}Y(t) &= c_1 e^{r_1 t} + c_2 e^{r_2 t} \text{ if } r_1 \text{ and } r_2 \text{ are distinct real numbers;} \\ Y(t) &= e^{r_1 t} (c_1 + c_2 t) \text{ if } r_1 = r_2; \\ Y(t) &= e^{\lambda t} (c_1 \cos \omega t + c_2 \sin \omega t) \text{ if } r_1, r_2 = \lambda \pm i\omega \text{ with } \omega \neq 0.\end{aligned}$$

Since  $Y(t) = y(e^t)$ , substituting  $t = \ln x$  in the last three equations shows that the general solution of (7.4.12) on  $(0, \infty)$  has the form stated in the theorem.

**Example 7.4.6** Find the general solution of

$$x^2 y'' - 5xy' + 9y = 0 \tag{7.4.15}$$

on  $(0, \infty)$ .

**Solution** The indicial polynomial of (7.4.15) is

$$p(r) = r(r-1) - 5r + 9 = (r-3)^2.$$

Therefore the general solution of (7.4.15) on  $(0, \infty)$  is

$$y = x^3(c_1 + c_2 \ln x).$$

**Example 7.4.7** Find the general solution of

$$x^2 y'' + 3xy' + 2y = 0 \tag{7.4.16}$$

on  $(0, \infty)$ .

**Solution** The indicial polynomial of (7.4.16) is

$$p(r) = r(r-1) + 3r + 2 = (r+1)^2 + 1.$$

The roots of the indicial equation are  $r = -1 \pm i$  and the general solution of (7.4.16) on  $(0, \infty)$  is

$$y = \frac{1}{x} [c_1 \cos(\ln x) + c_2 \sin(\ln x)].$$



## 7.4 Exercises

In Exercises 1–18 find the general solution of the given Euler equation on  $(0, \infty)$ .

- |                               |                                |
|-------------------------------|--------------------------------|
| 1. $x^2y'' + 7xy' + 8y = 0$   | 2. $x^2y'' - 7xy' + 7y = 0$    |
| 3. $x^2y'' - xy' + y = 0$     | 4. $x^2y'' + 5xy' + 4y = 0$    |
| 5. $x^2y'' + xy' + y = 0$     | 6. $x^2y'' - 3xy' + 13y = 0$   |
| 7. $x^2y'' + 3xy' - 3y = 0$   | 8. $12x^2y'' - 5xy' + 6y = 0$  |
| 9. $4x^2y'' + 8xy' + y = 0$   | 10. $3x^2y'' - xy' + y = 0$    |
| 11. $2x^2y'' - 3xy' + 2y = 0$ | 12. $x^2y'' + 3xy' + 5y = 0$   |
| 13. $9x^2y'' + 15xy' + y = 0$ | 14. $x^2y'' - xy' + 10y = 0$   |
| 15. $x^2y'' - 6y = 0$         | 16. $2x^2y'' + 3xy' - y = 0$   |
| 17. $x^2y'' - 3xy' + 4y = 0$  | 18. $2x^2y'' + 10xy' + 9y = 0$ |
19. (a) Adapt the proof of Theorem 7.4.3 to show that  $y = y(x)$  satisfies the Euler equation

$$ax^2y'' + bxy' + cy = 0 \quad (7.4.1)$$

on  $(-\infty, 0)$  if and only if  $Y(t) = y(-e^t)$

$$a \frac{d^2Y}{dt^2} + (b-a) \frac{dY}{dt} + cY = 0.$$

on  $(-\infty, \infty)$ .

(b) Use (a) to show that the general solution of (7.4.1) on  $(-\infty, 0)$  is

$$\begin{aligned} y &= c_1|x|^{r_1} + c_2|x|^{r_2} \text{ if } r_1 \text{ and } r_2 \text{ are distinct real numbers;} \\ y &= |x|^{r_1}(c_1 + c_2 \ln|x|) \text{ if } r_1 = r_2; \\ y &= |x|^\lambda [c_1 \cos(\omega \ln|x|) + c_2 \sin(\omega \ln|x|)] \text{ if } r_1, r_2 = \lambda \pm i\omega \text{ with } \omega > 0. \end{aligned}$$

20. Use reduction of order to show that if

$$ar(r-1) + br + c = 0$$

has a repeated root  $r_1$  then  $y = x^{r_1}(c_1 + c_2 \ln x)$  is the general solution of

$$ax^2y'' + bxy' + cy = 0$$

on  $(0, \infty)$ .

21. A nontrivial solution of

$$P_0(x)y'' + P_1(x)y' + P_2(x)y = 0$$

is said to be *oscillatory* on an interval  $(a, b)$  if it has infinitely many zeros on  $(a, b)$ . Otherwise  $y$  is said to be *nonoscillatory* on  $(a, b)$ . Show that the equation

$$x^2y'' + ky = 0 \quad (k = \text{constant})$$

has oscillatory solutions on  $(0, \infty)$  if and only if  $k > 1/4$ .

22. In Example 7.4.2 we saw that  $x_0 = 1$  and  $x_0 = -1$  are regular singular points of Legendre's equation

$$(1 - x^2)y'' - 2xy' + \alpha(\alpha + 1)y = 0. \quad (\text{A})$$

- (a) Introduce the new variables  $t = x - 1$  and  $Y(t) = y(t + 1)$ , and show that  $y$  is a solution of (A) if and only if  $Y$  is a solution of

$$t(2 + t)\frac{d^2Y}{dt^2} + 2(1 + t)\frac{dY}{dt} - \alpha(\alpha + 1)Y = 0,$$

which has a regular singular point at  $t_0 = 0$ .

- (b) Introduce the new variables  $t = x + 1$  and  $Y(t) = y(t - 1)$ , and show that  $y$  is a solution of (A) if and only if  $Y$  is a solution of

$$t(2 - t)\frac{d^2Y}{dt^2} + 2(1 - t)\frac{dY}{dt} + \alpha(\alpha + 1)Y = 0,$$

which has a regular singular point at  $t_0 = 0$ .

23. Let  $P_0, P_1,$  and  $P_2$  be polynomials with no common factor, and suppose  $x_0 \neq 0$  is a singular point of

$$P_0(x)y'' + P_1(x)y' + P_2(x)y = 0. \quad (\text{A})$$

Let  $t = x - x_0$  and  $Y(t) = y(t + x_0)$ .

- (a) Show that  $y$  is a solution of (A) if and only if  $Y$  is a solution of

$$R_0(t)\frac{d^2Y}{dt^2} + R_1(t)\frac{dY}{dt} + R_2(t)Y = 0. \quad (\text{B})$$

where

$$R_i(t) = P_i(t + x_0), \quad i = 0, 1, 2.$$

- (b) Show that  $R_0, R_1,$  and  $R_2$  are polynomials in  $t$  with no common factors, and  $R_0(0) = 0$ ; thus,  $t_0 = 0$  is a singular point of (B).

## 7.5 THE METHOD OF FROBENIUS I

In this section we begin to study series solutions of a homogeneous linear second order differential equation with a regular singular point at  $x_0 = 0$ , so it can be written as

$$x^2A(x)y'' + xB(x)y' + C(x)y = 0, \quad (7.5.1)$$

where  $A, B, C$  are polynomials and  $A(0) \neq 0$ .

We'll see that (7.5.1) always has at least one solution of the form

$$y = x^r \sum_{n=0}^{\infty} a_n x^n$$

where  $a_0 \neq 0$  and  $r$  is a suitably chosen number. The method we will use to find solutions of this form and other forms that we'll encounter in the next two sections is called *the method of Frobenius*, and we'll call them *Frobenius solutions*.

It can be shown that the power series  $\sum_{n=0}^{\infty} a_n x^n$  in a Frobenius solution of (7.5.1) converges on some open interval  $(-\rho, \rho)$ , where  $0 < \rho \leq \infty$ . However, since  $x^r$  may be complex for negative  $x$  or undefined if  $x = 0$ , we'll consider solutions defined for positive values of  $x$ . Easy modifications of our results yield solutions defined for negative values of  $x$ . (Exercise 54).

We'll restrict our attention to the case where  $A$ ,  $B$ , and  $C$  are polynomials of degree not greater than two, so (7.5.1) becomes

$$x^2(\alpha_0 + \alpha_1 x + \alpha_2 x^2)y'' + x(\beta_0 + \beta_1 x + \beta_2 x^2)y' + (\gamma_0 + \gamma_1 x + \gamma_2 x^2)y = 0, \quad (7.5.2)$$

where  $\alpha_i$ ,  $\beta_i$ , and  $\gamma_i$  are real constants and  $\alpha_0 \neq 0$ . Most equations that arise in applications can be written this way. Some examples are

$$\begin{aligned} \alpha x^2 y'' + \beta x y' + \gamma y &= 0 && \text{(Euler's equation),} \\ x^2 y'' + x y' + (x^2 - \nu^2) y &= 0 && \text{(Bessel's equation),} \end{aligned}$$

and

$$x y'' + (1 - x) y' + \lambda y = 0, \quad \text{(Laguerre's equation),}$$

where we would multiply the last equation through by  $x$  to put it in the form (7.5.2). However, the method of Frobenius can be extended to the case where  $A$ ,  $B$ , and  $C$  are functions that can be represented by power series in  $x$  on some interval that contains zero, and  $A_0(0) \neq 0$  (Exercises 57 and 58).

The next two theorems will enable us to develop systematic methods for finding Frobenius solutions of (7.5.2).

**Theorem 7.5.1** *Let*

$$Ly = x^2(\alpha_0 + \alpha_1 x + \alpha_2 x^2)y'' + x(\beta_0 + \beta_1 x + \beta_2 x^2)y' + (\gamma_0 + \gamma_1 x + \gamma_2 x^2)y,$$

*and define*

$$\begin{aligned} p_0(r) &= \alpha_0 r(r-1) + \beta_0 r + \gamma_0, \\ p_1(r) &= \alpha_1 r(r-1) + \beta_1 r + \gamma_1, \\ p_2(r) &= \alpha_2 r(r-1) + \beta_2 r + \gamma_2. \end{aligned}$$

*Suppose the series*

$$y = \sum_{n=0}^{\infty} a_n x^{n+r} \quad (7.5.3)$$

*converges on  $(0, \rho)$ . Then*

$$Ly = \sum_{n=0}^{\infty} b_n x^{n+r} \quad (7.5.4)$$

on  $(0, \rho)$ , where

$$\begin{aligned} b_0 &= p_0(r)a_0, \\ b_1 &= p_0(r+1)a_1 + p_1(r)a_0, \\ b_n &= p_0(n+r)a_n + p_1(n+r-1)a_{n-1} + p_2(n+r-2)a_{n-2}, \quad n \geq 2. \end{aligned} \quad (7.5.5)$$

**Proof** We begin by showing that if  $y$  is given by (7.5.3) and  $\alpha$ ,  $\beta$ , and  $\gamma$  are constants, then

$$\alpha x^2 y'' + \beta x y' + \gamma y = \sum_{n=0}^{\infty} p(n+r)a_n x^{n+r}, \quad (7.5.6)$$

where

$$p(r) = \alpha r(r-1) + \beta r + \gamma.$$

Differentiating (3) twice yields

$$y' = \sum_{n=0}^{\infty} (n+r)a_n x^{n+r-1} \quad (7.5.7)$$

and

$$y'' = \sum_{n=0}^{\infty} (n+r)(n+r-1)a_n x^{n+r-2}. \quad (7.5.8)$$

Multiplying (7.5.7) by  $x$  and (7.5.8) by  $x^2$  yields

$$x y' = \sum_{n=0}^{\infty} (n+r)a_n x^{n+r}$$

and

$$x^2 y'' = \sum_{n=0}^{\infty} (n+r)(n+r-1)a_n x^{n+r}.$$

Therefore

$$\begin{aligned} \alpha x^2 y'' + \beta x y' + \gamma y &= \sum_{n=0}^{\infty} [\alpha(n+r)(n+r-1) + \beta(n+r) + \gamma] a_n x^{n+r} \\ &= \sum_{n=0}^{\infty} p(n+r)a_n x^{n+r}, \end{aligned}$$

which proves (7.5.6).

Multiplying (7.5.6) by  $x$  yields

$$x(\alpha x^2 y'' + \beta x y' + \gamma y) = \sum_{n=0}^{\infty} p(n+r)a_n x^{n+r+1} = \sum_{n=1}^{\infty} p(n+r-1)a_{n-1} x^{n+r}. \quad (7.5.9)$$

Multiplying (7.5.6) by  $x^2$  yields

$$x^2(\alpha x^2 y'' + \beta x y' + \gamma y) = \sum_{n=0}^{\infty} p(n+r)a_n x^{n+r+2} = \sum_{n=2}^{\infty} p(n+r-2)a_{n-2} x^{n+r}. \quad (7.5.10)$$

To use these results, we rewrite

$$Ly = x^2(\alpha_0 + \alpha_1x + \alpha_2x^2)y'' + x(\beta_0 + \beta_1x + \beta_2x^2)y' + (\gamma_0 + \gamma_1x + \gamma_2x^2)y$$

as

$$\begin{aligned} Ly = & (\alpha_0x^2y'' + \beta_0xy' + \gamma_0y) + x(\alpha_1x^2y'' + \beta_1xy' + \gamma_1y) \\ & + x^2(\alpha_2x^2y'' + \beta_2xy' + \gamma_2y). \end{aligned} \quad (7.5.11)$$

From (7.5.6) with  $p = p_0$ ,

$$\alpha_0x^2y'' + \beta_0xy' + \gamma_0y = \sum_{n=0}^{\infty} p_0(n+r)a_nx^{n+r}.$$

From (7.5.9) with  $p = p_1$ ,

$$x(\alpha_1x^2y'' + \beta_1xy' + \gamma_1y) = \sum_{n=1}^{\infty} p_1(n+r-1)a_{n-1}x^{n+r}.$$

From (7.5.10) with  $p = p_2$ ,

$$x^2(\alpha_2x^2y'' + \beta_2xy' + \gamma_2y) = \sum_{n=2}^{\infty} p_2(n+r-2)a_{n-2}x^{n+r}.$$

Therefore we can rewrite (7.5.11) as

$$\begin{aligned} Ly = & \sum_{n=0}^{\infty} p_0(n+r)a_nx^{n+r} + \sum_{n=1}^{\infty} p_1(n+r-1)a_{n-1}x^{n+r} \\ & + \sum_{n=2}^{\infty} p_2(n+r-2)a_{n-2}x^{n+r}, \end{aligned}$$

or

$$\begin{aligned} Ly = & p_0(r)a_0x^r + [p_0(r+1)a_1 + p_1(r)a_2]x^{r+1} \\ & + \sum_{n=2}^{\infty} [p_0(n+r)a_n + p_1(n+r-1)a_{n-1} + p_2(n+r-2)a_{n-2}]x^{n+r}, \end{aligned}$$

which implies (7.5.4) with  $\{b_n\}$  defined as in (7.5.5).

**Theorem 7.5.2** *Let*

$$Ly = x^2(\alpha_0 + \alpha_1x + \alpha_2x^2)y'' + x(\beta_0 + \beta_1x + \beta_2x^2)y' + (\gamma_0 + \gamma_1x + \gamma_2x^2)y,$$

where  $\alpha_0 \neq 0$ , and define

$$\begin{aligned} p_0(r) &= \alpha_0r(r-1) + \beta_0r + \gamma_0, \\ p_1(r) &= \alpha_1r(r-1) + \beta_1r + \gamma_1, \\ p_2(r) &= \alpha_2r(r-1) + \beta_2r + \gamma_2. \end{aligned}$$

Suppose  $r$  is a real number such that  $p_0(n+r)$  is nonzero for all positive integers  $n$ . Define

$$\begin{aligned} a_0(r) &= 1, \\ a_1(r) &= -\frac{p_1(r)}{p_0(r+1)}, \\ a_n(r) &= -\frac{p_1(n+r-1)a_{n-1}(r) + p_2(n+r-2)a_{n-2}(r)}{p_0(n+r)}, \quad n \geq 2. \end{aligned} \quad (7.5.12)$$

Then the Frobenius series

$$y(x, r) = x^r \sum_{n=0}^{\infty} a_n(r)x^n \quad (7.5.13)$$

converges and satisfies

$$Ly(x, r) = p_0(r)x^r \quad (7.5.14)$$

on the interval  $(0, \rho)$ , where  $\rho$  is the distance from the origin to the nearest zero of  $A(x) = \alpha_0 + \alpha_1x + \alpha_2x^2$  in the complex plane. (If  $A$  is constant, then  $\rho = \infty$ .)

If  $\{a_n(r)\}$  is determined by the recurrence relation (7.5.12) then substituting  $a_n = a_n(r)$  into (7.5.5) yields  $b_0 = p_0(r)$  and  $b_n = 0$  for  $n \geq 1$ , so (7.5.4) reduces to (7.5.14). We omit the proof that the series (7.5.13) converges on  $(0, \rho)$ . ■

If  $\alpha_i = \beta_i = \gamma_i = 0$  for  $i = 1, 2$ , then  $Ly = 0$  reduces to the Euler equation

$$\alpha_0x^2y'' + \beta_0xy' + \gamma_0y = 0.$$

Theorem 7.4.3 shows that the solutions of this equation are determined by the zeros of the indicial polynomial

$$p_0(r) = \alpha_0r(r-1) + \beta_0r + \gamma_0.$$

Since (7.5.14) implies that this is also true for the solutions of  $Ly = 0$ , we'll also say that  $p_0$  is the *indicial polynomial* of (7.5.2), and that  $p_0(r) = 0$  is the *indicial equation* of  $Ly = 0$ . We'll consider only cases where the indicial equation has real roots  $r_1$  and  $r_2$ , with  $r_1 \geq r_2$ .

**Theorem 7.5.3** Let  $L$  and  $\{a_n(r)\}$  be as in Theorem 7.5.2, and suppose the indicial equation  $p_0(r) = 0$  of  $Ly = 0$  has real roots  $r_1$  and  $r_2$ , where  $r_1 \geq r_2$ . Then

$$y_1(x) = y(x, r_1) = x^{r_1} \sum_{n=0}^{\infty} a_n(r_1)x^n$$

is a Frobenius solution of  $Ly = 0$ . Moreover, if  $r_1 - r_2$  isn't an integer then

$$y_2(x) = y(x, r_2) = x^{r_2} \sum_{n=0}^{\infty} a_n(r_2)x^n$$

is also a Frobenius solution of  $Ly = 0$ , and  $\{y_1, y_2\}$  is a fundamental set of solutions.

**Proof** Since  $r_1$  and  $r_2$  are roots of  $p_0(r) = 0$ , the indicial polynomial can be factored as

$$p_0(r) = \alpha_0(r - r_1)(r - r_2). \quad (7.5.15)$$

Therefore

$$p_0(n + r_1) = n\alpha_0(n + r_1 - r_2),$$

which is nonzero if  $n > 0$ , since  $r_1 - r_2 \geq 0$ . Therefore the assumptions of Theorem 7.5.2 hold with  $r = r_1$ , and (7.5.14) implies that  $Ly_1 = p_0(r_1)x^{r_1} = 0$ .

Now suppose  $r_1 - r_2$  isn't an integer. From (7.5.15),

$$p_0(n + r_2) = n\alpha_0(n - r_1 + r_2) \neq 0 \quad \text{if } n = 1, 2, \dots$$

Hence, the assumptions of Theorem 7.5.2 hold with  $r = r_2$ , and (7.5.14) implies that  $Ly_2 = p_0(r_2)x^{r_2} = 0$ . We leave the proof that  $\{y_1, y_2\}$  is a fundamental set of solutions as an exercise (Exercise 52). ■

It isn't always possible to obtain explicit formulas for the coefficients in Frobenius solutions. However, we can always set up the recurrence relations and use them to compute as many coefficients as we want. The next example illustrates this.

**Example 7.5.1** Find a fundamental set of Frobenius solutions of

$$2x^2(1 + x + x^2)y'' + x(9 + 11x + 11x^2)y' + (6 + 10x + 7x^2)y = 0. \quad (7.5.16)$$

Compute just the first six coefficients  $a_0, \dots, a_5$  in each solution.

**Solution** For the given equation, the polynomials defined in Theorem 7.5.2 are

$$\begin{aligned} p_0(r) &= 2r(r-1) + 9r + 6 = (2r+3)(r+2), \\ p_1(r) &= 2r(r-1) + 11r + 10 = (2r+5)(r+2), \\ p_2(r) &= 2r(r-1) + 11r + 7 = (2r+7)(r+1). \end{aligned}$$

The zeros of the indicial polynomial  $p_0$  are  $r_1 = -3/2$  and  $r_2 = -2$ , so  $r_1 - r_2 = 1/2$ . Therefore Theorem 7.5.3 implies that

$$y_1 = x^{-3/2} \sum_{n=0}^{\infty} a_n(-3/2)x^n \quad \text{and} \quad y_2 = x^{-2} \sum_{n=0}^{\infty} a_n(-2)x^n \quad (7.5.17)$$

form a fundamental set of Frobenius solutions of (7.5.16). To find the coefficients in these series, we use the recurrence relation of Theorem 7.5.2; thus,

$$\begin{aligned} a_0(r) &= 1, \\ a_1(r) &= -\frac{p_1(r)}{p_0(r+1)} = -\frac{(2r+5)(r+2)}{(2r+5)(r+3)} = -\frac{r+2}{r+3}, \\ a_n(r) &= -\frac{p_1(n+r-1)a_{n-1} + p_2(n+r-2)a_{n-2}}{p_0(n+r)} \\ &= -\frac{(n+r+1)(2n+2r+3)a_{n-1}(r) + (n+r-1)(2n+2r+3)a_{n-2}(r)}{(n+r+2)(2n+2r+3)} \\ &= -\frac{(n+r+1)a_{n-1}(r) + (n+r-1)a_{n-2}(r)}{n+r+2}, \quad n \geq 2. \end{aligned}$$

Setting  $r = -3/2$  in these equations yields

$$\begin{aligned} a_0(-3/2) &= 1, \\ a_1(-3/2) &= -1/3, \\ a_n(-3/2) &= -\frac{(2n-1)a_{n-1}(-3/2) + (2n-5)a_{n-2}(-3/2)}{2n+1}, \quad n \geq 2, \end{aligned} \quad (7.5.18)$$

and setting  $r = -2$  yields

$$\begin{aligned} a_0(-2) &= 1, \\ a_1(-2) &= 0, \\ a_n(-2) &= -\frac{(n-1)a_{n-1}(-2) + (n-3)a_{n-2}(-2)}{n}, \quad n \geq 2. \end{aligned} \tag{7.5.19}$$

Calculating with (7.5.18) and (7.5.19) and substituting the results into (7.5.17) yields the fundamental set of Frobenius solutions

$$\begin{aligned} y_1 &= x^{-3/2} \left( 1 - \frac{1}{3}x + \frac{2}{5}x^2 - \frac{5}{21}x^3 + \frac{7}{135}x^4 + \frac{76}{1155}x^5 + \cdots \right), \\ y_2 &= x^{-2} \left( 1 + \frac{1}{2}x^2 - \frac{1}{3}x^3 + \frac{1}{8}x^4 + \frac{1}{30}x^5 + \cdots \right). \end{aligned}$$

### Special Cases With Two Term Recurrence Relations

For  $n \geq 2$ , the recurrence relation (7.5.12) of Theorem 7.5.2 involves the three coefficients  $a_n(r)$ ,  $a_{n-1}(r)$ , and  $a_{n-2}(r)$ . We'll now consider some special cases where (7.5.12) reduces to a two term recurrence relation; that is, a relation involving only  $a_n(r)$  and  $a_{n-1}(r)$  or only  $a_n(r)$  and  $a_{n-2}(r)$ . This simplification often makes it possible to obtain explicit formulas for the coefficients of Frobenius solutions.

We first consider equations of the form

$$x^2(\alpha_0 + \alpha_1x)y'' + x(\beta_0 + \beta_1x)y' + (\gamma_0 + \gamma_1x)y = 0$$

with  $\alpha_0 \neq 0$ . For this equation,  $\alpha_2 = \beta_2 = \gamma_2 = 0$ , so  $p_2 \equiv 0$  and the recurrence relations in Theorem 7.5.2 simplify to

$$\begin{aligned} a_0(r) &= 1, \\ a_n(r) &= -\frac{p_1(n+r-1)}{p_0(n+r)}a_{n-1}(r), \quad n \geq 1. \end{aligned} \tag{7.5.20}$$

**Example 7.5.2** Find a fundamental set of Frobenius solutions of

$$x^2(3+x)y'' + 5x(1+x)y' - (1-4x)y = 0. \tag{7.5.21}$$

Give explicit formulas for the coefficients in the solutions.

**Solution** For this equation, the polynomials defined in Theorem 7.5.2 are

$$\begin{aligned} p_0(r) &= 3r(r-1) + 5r - 1 = (3r-1)(r+1), \\ p_1(r) &= r(r-1) + 5r + 4 = (r+2)^2, \\ p_2(r) &= 0. \end{aligned}$$

The zeros of the indicial polynomial  $p_0$  are  $r_1 = 1/3$  and  $r_2 = -1$ , so  $r_1 - r_2 = 4/3$ . Therefore Theorem 7.5.3 implies that

$$y_1 = x^{1/3} \sum_{n=0}^{\infty} a_n(1/3)x^n \quad \text{and} \quad y_2 = x^{-1} \sum_{n=0}^{\infty} a_n(-1)x^n$$



form a fundamental set of Frobenius solutions of (7.5.21). To find the coefficients in these series, we use the recurrence relations (7.5.20); thus,

$$\begin{aligned} a_0(r) &= 1, \\ a_n(r) &= -\frac{p_1(n+r-1)}{p_0(n+r)}a_{n-1}(r) \\ &= -\frac{(n+r+1)^2}{(3n+3r-1)(n+r+1)}a_{n-1}(r) \\ &= -\frac{n+r+1}{3n+3r-1}a_{n-1}(r), \quad n \geq 1. \end{aligned} \tag{7.5.22}$$

Setting  $r = 1/3$  in (7.5.22) yields

$$\begin{aligned} a_0(1/3) &= 1, \\ a_n(1/3) &= -\frac{3n+4}{9n}a_{n-1}(1/3), \quad n \geq 1. \end{aligned}$$

By using the product notation introduced in Section 7.2 and proceeding as we did in the examples in that section yields

$$a_n(1/3) = \frac{(-1)^n \prod_{j=1}^n (3j+4)}{9^n n!}, \quad n \geq 0.$$

Therefore

$$y_1 = x^{1/3} \sum_{n=0}^{\infty} \frac{(-1)^n \prod_{j=1}^n (3j+4)}{9^n n!} x^n$$

is a Frobenius solution of (7.5.21).

Setting  $r = -1$  in (7.5.22) yields

$$\begin{aligned} a_0(-1) &= 1, \\ a_n(-1) &= -\frac{n}{3n-4}a_{n-1}(-1), \quad n \geq 1, \end{aligned}$$

so

$$a_n(-1) = \frac{(-1)^n n!}{\prod_{j=1}^n (3j-4)}.$$

Therefore

$$y_2 = x^{-1} \sum_{n=0}^{\infty} \frac{(-1)^n n!}{\prod_{j=1}^n (3j-4)} x^n$$

is a Frobenius solution of (7.5.21), and  $\{y_1, y_2\}$  is a fundamental set of solutions. ■

We now consider equations of the form

$$x^2(\alpha_0 + \alpha_2 x^2)y'' + x(\beta_0 + \beta_2 x^2)y' + (\gamma_0 + \gamma_2 x^2)y = 0 \tag{7.5.23}$$

with  $\alpha_0 \neq 0$ . For this equation,  $\alpha_1 = \beta_1 = \gamma_1 = 0$ , so  $p_1 \equiv 0$  and the recurrence relations in Theorem 7.5.2 simplify to

$$\begin{aligned} a_0(r) &= 1, \\ a_1(r) &= 0, \\ a_n(r) &= -\frac{p_2(n+r-2)}{p_0(n+r)}a_{n-2}(r), \quad n \geq 2. \end{aligned}$$

Since  $a_1(r) = 0$ , the last equation implies that  $a_n(r) = 0$  if  $n$  is odd, so the Frobenius solutions are of the form

$$y(x, r) = x^r \sum_{m=0}^{\infty} a_{2m}(r) x^{2m},$$

where

$$\begin{aligned} a_0(r) &= 1, \\ a_{2m}(r) &= -\frac{p_2(2m+r-2)}{p_0(2m+r)} a_{2m-2}(r), \quad m \geq 1. \end{aligned} \quad (7.5.24)$$

**Example 7.5.3** Find a fundamental set of Frobenius solutions of

$$x^2(2-x^2)y'' - x(3+4x^2)y' + (2-2x^2)y = 0. \quad (7.5.25)$$

Give explicit formulas for the coefficients in the solutions.

**Solution** For this equation, the polynomials defined in Theorem 7.5.2 are

$$\begin{aligned} p_0(r) &= 2r(r-1) - 3r + 2 = (r-2)(2r-1), \\ p_1(r) &= 0 \\ p_2(r) &= -[r(r-1) + 4r + 2] = -(r+1)(r+2). \end{aligned}$$

The zeros of the indicial polynomial  $p_0$  are  $r_1 = 2$  and  $r_2 = 1/2$ , so  $r_1 - r_2 = 3/2$ . Therefore Theorem 7.5.3 implies that

$$y_1 = x^2 \sum_{m=0}^{\infty} a_{2m}(1/3) x^{2m} \quad \text{and} \quad y_2 = x^{1/2} \sum_{m=0}^{\infty} a_{2m}(1/2) x^{2m}$$

form a fundamental set of Frobenius solutions of (7.5.25). To find the coefficients in these series, we use the recurrence relation (7.5.24); thus,

$$\begin{aligned} a_0(r) &= 1, \\ a_{2m}(r) &= -\frac{p_2(2m+r-2)}{p_0(2m+r)} a_{2m-2}(r) \\ &= \frac{(2m+r)(2m+r-1)}{(2m+r-2)(4m+2r-1)} a_{2m-2}(r), \quad m \geq 1. \end{aligned} \quad (7.5.26)$$

Setting  $r = 2$  in (7.5.26) yields

$$\begin{aligned} a_0(2) &= 1, \\ a_{2m}(2) &= \frac{(m+1)(2m+1)}{m(4m+3)} a_{2m-2}(2), \quad m \geq 1, \end{aligned}$$

so

$$a_{2m}(2) = (m+1) \prod_{j=1}^m \frac{2j+1}{4j+3}.$$

Therefore

$$y_1 = x^2 \sum_{m=0}^{\infty} (m+1) \left( \prod_{j=1}^m \frac{2j+1}{4j+3} \right) x^{2m}$$

is a Frobenius solution of (7.5.25).

Setting  $r = 1/2$  in (7.5.26) yields

$$\begin{aligned} a_0(1/2) &= 1, \\ a_{2m}(1/2) &= \frac{(4m-1)(4m+1)}{8m(4m-3)} a_{2m-2}(1/2), \quad m \geq 1, \end{aligned}$$

so

$$a_{2m}(1/2) = \frac{1}{8^m m!} \prod_{j=1}^m \frac{(4j-1)(4j+1)}{4j-3}.$$

Therefore

$$y_2 = x^{1/2} \sum_{m=0}^{\infty} \frac{1}{8^m m!} \left( \prod_{j=1}^m \frac{(4j-1)(4j+1)}{4j-3} \right) x^{2m}$$

is a Frobenius solution of (7.5.25) and  $\{y_1, y_2\}$  is a fundamental set of solutions.

**REMARK:** Thus far, we considered only the case where the indicial equation has real roots that don't differ by an integer, which allows us to apply Theorem 7.5.3. However, for equations of the form (7.5.23), the sequence  $\{a_{2m}(r)\}$  in (7.5.24) is defined for  $r = r_2$  if  $r_1 - r_2$  isn't an *even* integer. It can be shown (Exercise 56) that in this case

$$y_1 = x^{r_1} \sum_{m=0}^{\infty} a_{2m}(r_1) x^{2m} \quad \text{and} \quad y_2 = x^{r_2} \sum_{m=0}^{\infty} a_{2m}(r_2) x^{2m}$$

form a fundamental set Frobenius solutions of (7.5.23).

#### USING TECHNOLOGY

As we said at the end of Section 7.2, if you're interested in actually using series to compute numerical approximations to solutions of a differential equation, then whether or not there's a simple closed form for the coefficients is essentially irrelevant; recursive computation is usually more efficient. Since it's also laborious, we encourage you to write short programs to implement recurrence relations on a calculator or computer, even in exercises where this is not specifically required.

In practical use of the method of Frobenius when  $x_0 = 0$  is a regular singular point, we're interested in how well the functions

$$y_N(x, r_i) = x^{r_i} \sum_{n=0}^N a_n(r_i) x^n, \quad i = 1, 2,$$

approximate solutions to a given equation when  $r_i$  is a zero of the indicial polynomial. In dealing with the corresponding problem for the case where  $x_0 = 0$  is an ordinary point, we used numerical integration to solve the differential equation subject to initial conditions  $y(0) = a_0$ ,  $y'(0) = a_1$ , and compared the result with values of the Taylor polynomial

$$T_N(x) = \sum_{n=0}^N a_n x^n.$$

We can't do that here, since in general we can't prescribe arbitrary initial values for solutions of a differential equation at a singular point. Therefore, motivated by Theorem 7.5.2 (specifically, (7.5.14)), we suggest the following procedure.

**Verification Procedure**

Let  $L$  and  $Y_n(x; r_i)$  be defined by

$$Ly = x^2(\alpha_0 + \alpha_1x + \alpha_2x^2)y'' + x(\beta_0 + \beta_1x + \beta_2x^2)y' + (\gamma_0 + \gamma_1x + \gamma_2x^2)y$$

and

$$y_N(x; r_i) = x^{r_i} \sum_{n=0}^N a_n(r_i)x^n,$$

where the coefficients  $\{a_n(r_i)\}_{n=0}^N$  are computed as in (7.5.12), Theorem 7.5.2. Compute the error

$$E_N(x; r_i) = x^{-r_i} Ly_N(x; r_i) / \alpha_0 \quad (7.5.27)$$

for various values of  $N$  and various values of  $x$  in the interval  $(0, \rho)$ , with  $\rho$  as defined in Theorem 7.5.2.

The multiplier  $x^{-r_i} / \alpha_0$  on the right of (7.5.27) eliminates the effects of small or large values of  $x^{r_i}$  near  $x = 0$ , and of multiplication by an arbitrary constant. In some exercises you will be asked to estimate the maximum value of  $E_N(x; r_i)$  on an interval  $(0, \delta]$  by computing  $E_N(x_m; r_i)$  at the  $M$  points  $x_m = m\delta/M$ ,  $m = 1, 2, \dots, M$ , and finding the maximum of the absolute values:

$$\sigma_N(\delta) = \max\{|E_N(x_m; r_i)|, m = 1, 2, \dots, M\}. \quad (7.5.28)$$

(For simplicity, this notation ignores the dependence of the right side of the equation on  $i$  and  $M$ .)

To implement this procedure, you'll have to write a computer program to calculate  $\{a_n(r_i)\}$  from the applicable recurrence relation, and to evaluate  $E_N(x; r_i)$ .

The next exercise set contains five exercises specifically identified by **L** that ask you to implement the verification procedure. These particular exercises were chosen arbitrarily you can just as well formulate such laboratory problems for any of the equations in any of the Exercises 1–10, 14–25, and 28–51

**7.5 Exercises**

This set contains exercises specifically identified by **L** that ask you to implement the verification procedure. These particular exercises were chosen arbitrarily you can just as well formulate such laboratory problems for any of the equations in Exercises 1–10, 14–25, and 28–51.

In Exercises 1–10 find a fundamental set of Frobenius solutions. Compute  $a_0, a_1, \dots, a_N$  for  $N$  at least 7 in each solution.

1. **C**  $2x^2(1 + x + x^2)y'' + x(3 + 3x + 5x^2)y' - y = 0$
2. **C**  $3x^2y'' + 2x(1 + x - 2x^2)y' + (2x - 8x^2)y = 0$
3. **C**  $x^2(3 + 3x + x^2)y'' + x(5 + 8x + 7x^2)y' - (1 - 2x - 9x^2)y = 0$
4. **C**  $4x^2y'' + x(7 + 2x + 4x^2)y' - (1 - 4x - 7x^2)y = 0$
5. **C**  $12x^2(1 + x)y'' + x(11 + 35x + 3x^2)y' - (1 - 10x - 5x^2)y = 0$
6. **C**  $x^2(5 + x + 10x^2)y'' + x(4 + 3x + 48x^2)y' + (x + 36x^2)y = 0$
7. **C**  $8x^2y'' - 2x(3 - 4x - x^2)y' + (3 + 6x + x^2)y = 0$
8. **C**  $18x^2(1 + x)y'' + 3x(5 + 11x + x^2)y' - (1 - 2x - 5x^2)y = 0$
9. **C**  $x(3 + x + x^2)y'' + (4 + x - x^2)y' + xy = 0$

10.  $\boxed{\text{C}}$   $10x^2(1+x+2x^2)y'' + x(13+13x+66x^2)y' - (1+4x+10x^2)y = 0$

11.  $\boxed{\text{L}}$  The Frobenius solutions of

$$2x^2(1+x+x^2)y'' + x(9+11x+11x^2)y' + (6+10x+7x^2)y = 0$$

obtained in Example 7.5.1 are defined on  $(0, \rho)$ , where  $\rho$  is defined in Theorem 7.5.2. Find  $\rho$ . Then do the following experiments for each Frobenius solution, with  $M = 20$  and  $\delta = .5\rho, .7\rho$ , and  $.9\rho$  in the verification procedure described at the end of this section.

(a) Compute  $\sigma_N(\delta)$  (see Eqn. (7.5.28)) for  $N = 5, 10, 15, \dots, 50$ .

(b) Find  $N$  such that  $\sigma_N(\delta) < 10^{-5}$ .

(c) Find  $N$  such that  $\sigma_N(\delta) < 10^{-10}$ .

12.  $\boxed{\text{L}}$  By Theorem 7.5.2 the Frobenius solutions of the equation in Exercise 4 are defined on  $(0, \infty)$ . Do experiments (a), (b), and (c) of Exercise 11 for each Frobenius solution, with  $M = 20$  and  $\delta = 1, 2$ , and  $3$  in the verification procedure described at the end of this section.

13.  $\boxed{\text{L}}$  The Frobenius solutions of the equation in Exercise 6 are defined on  $(0, \rho)$ , where  $\rho$  is defined in Theorem 7.5.2. Find  $\rho$  and do experiments (a), (b), and (c) of Exercise 11 for each Frobenius solution, with  $M = 20$  and  $\delta = .3\rho, .4\rho$ , and  $.5\rho$ , in the verification procedure described at the end of this section.

*In Exercises 14–25 find a fundamental set of Frobenius solutions. Give explicit formulas for the coefficients in each solution.*

14.  $2x^2y'' + x(3+2x)y' - (1-x)y = 0$

15.  $x^2(3+x)y'' + x(5+4x)y' - (1-2x)y = 0$

16.  $2x^2y'' + x(5+x)y' - (2-3x)y = 0$

17.  $3x^2y'' + x(1+x)y' - y = 0$

18.  $2x^2y'' - xy' + (1-2x)y = 0$

19.  $9x^2y'' + 9xy' - (1+3x)y = 0$

20.  $3x^2y'' + x(1+x)y' - (1+3x)y = 0$

21.  $2x^2(3+x)y'' + x(1+5x)y' + (1+x)y = 0$

22.  $x^2(4+x)y'' - x(1-3x)y' + y = 0$

23.  $2x^2y'' + 5xy' + (1+x)y = 0$

24.  $x^2(3+4x)y'' + x(5+18x)y' - (1-12x)y = 0$

25.  $6x^2y'' + x(10-x)y' - (2+x)y = 0$

26.  $\boxed{\text{L}}$  By Theorem 7.5.2 the Frobenius solutions of the equation in Exercise 17 are defined on  $(0, \infty)$ . Do experiments (a), (b), and (c) of Exercise 11 for each Frobenius solution, with  $M = 20$  and  $\delta = 3, 6, 9$ , and  $12$  in the verification procedure described at the end of this section.

27.  $\boxed{\text{L}}$  The Frobenius solutions of the equation in Exercise 22 are defined on  $(0, \rho)$ , where  $\rho$  is defined in Theorem 7.5.2. Find  $\rho$  and do experiments (a), (b), and (c) of Exercise 11 for each Frobenius solution, with  $M = 20$  and  $\delta = .25\rho, .5\rho$ , and  $.75\rho$  in the verification procedure described at the end of this section.

In Exercises 28–32 find a fundamental set of Frobenius solutions. Compute coefficients  $a_0, \dots, a_N$  for  $N$  at least 7 in each solution.

28.   $x^2(8+x)y'' + x(2+3x)y' + (1+x)y = 0$   
 29.   $x^2(3+4x)y'' + x(11+4x)y' - (3+4x)y = 0$   
 30.   $2x^2(2+3x)y'' + x(4+11x)y' - (1-x)y = 0$   
 31.   $x^2(2+x)y'' + 5x(1-x)y' - (2-8x)y$   
 32.   $x^2(6+x)y'' + x(11+4x)y' + (1+2x)y = 0$

In Exercises 33–46 find a fundamental set of Frobenius solutions. Give explicit formulas for the coefficients in each solution.

33.  $8x^2y'' + x(2+x^2)y' + y = 0$   
 34.  $8x^2(1-x^2)y'' + 2x(1-13x^2)y' + (1-9x^2)y = 0$   
 35.  $x^2(1+x^2)y'' - 2x(2-x^2)y' + 4y = 0$   
 36.  $x(3+x^2)y'' + (2-x^2)y' - 8xy = 0$   
 37.  $4x^2(1-x^2)y'' + x(7-19x^2)y' - (1+14x^2)y = 0$   
 38.  $3x^2(2-x^2)y'' + x(1-11x^2)y' + (1-5x^2)y = 0$   
 39.  $2x^2(2+x^2)y'' - x(12-7x^2)y' + (7+3x^2)y = 0$   
 40.  $2x^2(2+x^2)y'' + x(4+7x^2)y' - (1-3x^2)y = 0$   
 41.  $2x^2(1+2x^2)y'' + 5x(1+6x^2)y' - (2-40x^2)y = 0$   
 42.  $3x^2(1+x^2)y'' + 5x(1+x^2)y' - (1+5x^2)y = 0$   
 43.  $x(1+x^2)y'' + (4+7x^2)y' + 8xy = 0$   
 44.  $x^2(2+x^2)y'' + x(3+x^2)y' - y = 0$   
 45.  $2x^2(1+x^2)y'' + x(3+8x^2)y' - (3-4x^2)y = 0$   
 46.  $9x^2y'' + 3x(3+x^2)y' - (1-5x^2)y = 0$

In Exercises 47–51 find a fundamental set of Frobenius solutions. Compute the coefficients  $a_0, \dots, a_{2M}$  for  $M$  at least 7 in each solution.

47.   $6x^2y'' + x(1+6x^2)y' + (1+9x^2)y = 0$   
 48.   $x^2(8+x^2)y'' + 7x(2+x^2)y' - (2-9x^2)y = 0$   
 49.   $9x^2(1+x^2)y'' + 3x(3+13x^2)y' - (1-25x^2)y = 0$   
 50.   $4x^2(1+x^2)y'' + 4x(1+6x^2)y' - (1-25x^2)y = 0$   
 51.   $8x^2(1+2x^2)y'' + 2x(5+34x^2)y' - (1-30x^2)y = 0$   
 52. Suppose  $r_1 > r_2$ ,  $a_0 = b_0 = 1$ , and the Frobenius series

$$y_1 = x^{r_1} \sum_{n=0}^{\infty} a_n x^n \quad \text{and} \quad y_2 = x^{r_2} \sum_{n=0}^{\infty} b_n x^n$$

both converge on an interval  $(0, \rho)$ .

- (a) Show that  $y_1$  and  $y_2$  are linearly independent on  $(0, \rho)$ . HINT: Show that if  $c_1$  and  $c_2$  are constants such that  $c_1 y_1 + c_2 y_2 \equiv 0$  on  $(0, \rho)$ , then

$$c_1 x^{r_1-r_2} \sum_{n=0}^{\infty} a_n x^n + c_2 \sum_{n=0}^{\infty} b_n x^n = 0, \quad 0 < x < \rho.$$

Then let  $x \rightarrow 0+$  to conclude that  $c_2 = 0$ .

- (b) Use the result of (b) to complete the proof of Theorem 7.5.3.

53. The equation

$$x^2 y'' + x y' + (x^2 - \nu^2) y = 0 \quad (7.5.1)$$

is *Bessel's equation of order  $\nu$* . (Here  $\nu$  is a parameter, and this use of "order" should not be confused with its usual use as in "the order of the equation.") The solutions of (7.5.1) are *Bessel functions of order  $\nu$* .

- (a) Assuming that  $\nu$  isn't an integer, find a fundamental set of Frobenius solutions of (7.5.1).  
 (b) If  $\nu = 1/2$ , the solutions of (7.5.1) reduce to familiar elementary functions. Identify these functions.

54. (a) Verify that

$$\frac{d}{dx} (|x|^r x^n) = (n+r)|x|^r x^{n-1} \quad \text{and} \quad \frac{d^2}{dx^2} (|x|^r x^n) = (n+r)(n+r-1)|x|^r x^{n-2}$$

if  $x \neq 0$ .

- (b) Let

$$Ly = x^2(\alpha_0 + \alpha_1 x + \alpha_2 x^2)y'' + x(\beta_0 + \beta_1 x + \beta_2 x^2)y' + (\gamma_0 + \gamma_1 x + \gamma_2 x^2)y = 0.$$

Show that if  $x^r \sum_{n=0}^{\infty} a_n x^n$  is a solution of  $Ly = 0$  on  $(0, \rho)$  then  $|x|^r \sum_{n=0}^{\infty} a_n x^n$  is a solution on  $(-\rho, 0)$  and  $(0, \rho)$ .

55. (a) Deduce from Eqn. (7.5.20) that

$$a_n(r) = (-1)^n \prod_{j=1}^n \frac{p_1(j+r-1)}{p_0(j+r)}.$$

- (b) Conclude that if  $p_0(r) = \alpha_0(r-r_1)(r-r_2)$  where  $r_1 - r_2$  is not an integer, then

$$y_1 = x^{r_1} \sum_{n=0}^{\infty} a_n(r_1) x^n \quad \text{and} \quad y_2 = x^{r_2} \sum_{n=0}^{\infty} a_n(r_2) x^n$$

form a fundamental set of Frobenius solutions of

$$x^2(\alpha_0 + \alpha_1 x)y'' + x(\beta_0 + \beta_1 x)y' + (\gamma_0 + \gamma_1 x)y = 0.$$

- (c) Show that if  $p_0$  satisfies the hypotheses of (b) then

$$y_1 = x^{r_1} \sum_{n=0}^{\infty} \frac{(-1)^n}{n! \prod_{j=1}^n (j+r_1-r_2)} \left( \frac{\gamma_1}{\alpha_0} \right)^n x^n$$

and

$$y_2 = x^{r_2} \sum_{n=0}^{\infty} \frac{(-1)^n}{n! \prod_{j=1}^n (j+r_2-r_1)} \left( \frac{\gamma_1}{\alpha_0} \right)^n x^n$$

form a fundamental set of Frobenius solutions of

$$\alpha_0 x^2 y'' + \beta_0 x y' + (\gamma_0 + \gamma_1 x) y = 0.$$

56. Let

$$Ly = x^2(\alpha_0 + \alpha_2 x^2)y'' + x(\beta_0 + \beta_2 x^2)y' + (\gamma_0 + \gamma_2 x^2)y = 0$$

and define

$$p_0(r) = \alpha_0 r(r-1) + \beta_0 r + \gamma_0 \quad \text{and} \quad p_2(r) = \alpha_2 r(r-1) + \beta_2 r + \gamma_2.$$

(a) Use Theorem 7.5.2 to show that if

$$\begin{aligned} a_0(r) &= 1, \\ p_0(2m+r)a_{2m}(r) + p_2(2m+r-2)a_{2m-2}(r) &= 0, \quad m \geq 1, \end{aligned} \quad (7.5.1)$$

then the Frobenius series  $y(x, r) = x^r \sum_{m=0}^{\infty} a_{2m} x^{2m}$  satisfies  $Ly(x, r) = p_0(r)x^r$ .

(b) Deduce from (7.5.1) that if  $p_0(2m+r)$  is nonzero for every positive integer  $m$  then

$$a_{2m}(r) = (-1)^m \prod_{j=1}^m \frac{p_2(2j+r-2)}{p_0(2j+r)}.$$

(c) Conclude that if  $p_0(r) = \alpha_0(r-r_1)(r-r_2)$  where  $r_1 - r_2$  is not an even integer, then

$$y_1 = x^{r_1} \sum_{m=0}^{\infty} a_{2m}(r_1)x^{2m} \quad \text{and} \quad y_2 = x^{r_2} \sum_{m=0}^{\infty} a_{2m}(r_2)x^{2m}$$

form a fundamental set of Frobenius solutions of  $Ly = 0$ .

(d) Show that if  $p_0$  satisfies the hypotheses of (c) then

$$y_1 = x^{r_1} \sum_{m=0}^{\infty} \frac{(-1)^m}{2^m m! \prod_{j=1}^m (2j+r_1-r_2)} \left( \frac{\gamma_2}{\alpha_0} \right)^m x^{2m}$$

and

$$y_2 = x^{r_2} \sum_{m=0}^{\infty} \frac{(-1)^m}{2^m m! \prod_{j=1}^m (2j+r_2-r_1)} \left( \frac{\gamma_2}{\alpha_0} \right)^m x^{2m}$$

form a fundamental set of Frobenius solutions of

$$\alpha_0 x^2 y'' + \beta_0 x y' + (\gamma_0 + \gamma_2 x^2) y = 0.$$

57. Let

$$Ly = x^2 q_0(x)y'' + x q_1(x)y' + q_2(x)y,$$

where

$$q_0(x) = \sum_{j=0}^{\infty} \alpha_j x^j, \quad q_1(x) = \sum_{j=0}^{\infty} \beta_j x^j, \quad q_2(x) = \sum_{j=0}^{\infty} \gamma_j x^j,$$

and define

$$p_j(r) = \alpha_j r(r-1) + \beta_j r + \gamma_j, \quad j = 0, 1, \dots$$

Let  $y = x^r \sum_{n=0}^{\infty} a_n x^n$ . Show that

$$Ly = x^r \sum_{n=0}^{\infty} b_n x^n,$$

where

$$b_n = \sum_{j=0}^n p_j(n+r-j)a_{n-j}.$$



58. (a) Let  $L$  be as in Exercise 57. Show that if

$$y(x, r) = x^r \sum_{n=0}^{\infty} a_n(r)x^n$$

where

$$\begin{aligned} a_0(r) &= 1, \\ a_n(r) &= -\frac{1}{p_0(n+r)} \sum_{j=1}^n p_j(n+r-j)a_{n-j}(r), \quad n \geq 1, \end{aligned}$$

then

$$Ly(x, r) = p_0(r)x^r.$$

(b) Conclude that if

$$p_0(r) = \alpha_0(r - r_1)(r - r_2)$$

where  $r_1 - r_2$  isn't an integer then  $y_1 = y(x, r_1)$  and  $y_2 = y(x, r_2)$  are solutions of  $Ly = 0$ .

59. Let

$$Ly = x^2(\alpha_0 + \alpha_q x^q)y'' + x(\beta_0 + \beta_q x^q)y' + (\gamma_0 + \gamma_q x^q)y$$

where  $q$  is a positive integer, and define

$$p_0(r) = \alpha_0 r(r-1) + \beta_0 r + \gamma_0 \quad \text{and} \quad p_q(r) = \alpha_q r(r-1) + \beta_q r + \gamma_q.$$

(a) Show that if

$$y(x, r) = x^r \sum_{m=0}^{\infty} a_{qm}(r)x^{qm}$$

where

$$\begin{aligned} a_0(r) &= 1, \\ a_{qm}(r) &= -\frac{p_q(q(m-1)+r)}{p_0(qm+r)} a_{q(m-1)}(r), \quad m \geq 1, \end{aligned} \tag{7.5.1}$$

then

$$Ly(x, r) = p_0(r)x^r.$$

(b) Deduce from (7.5.1) that

$$a_{qm}(r) = (-1)^m \prod_{j=1}^m \frac{p_q(q(j-1)+r)}{p_0(qj+r)}.$$

(c) Conclude that if  $p_0(r) = \alpha_0(r - r_1)(r - r_2)$  where  $r_1 - r_2$  is not an integer multiple of  $q$ , then

$$y_1 = x^{r_1} \sum_{m=0}^{\infty} a_{qm}(r_1)x^{qm} \quad \text{and} \quad y_2 = x^{r_2} \sum_{m=0}^{\infty} a_{qm}(r_2)x^{qm}$$

form a fundamental set of Frobenius solutions of  $Ly = 0$ .

(d) Show that if  $p_0$  satisfies the hypotheses of (c) then

$$y_1 = x^{r_1} \sum_{m=0}^{\infty} \frac{(-1)^m}{q^m m! \prod_{j=1}^m (qj + r_1 - r_2)} \left(\frac{\gamma q}{\alpha_0}\right)^m x^{qm}$$

and

$$y_2 = x^{r_2} \sum_{m=0}^{\infty} \frac{(-1)^m}{q^m m! \prod_{j=1}^m (qj + r_2 - r_1)} \left(\frac{\gamma q}{\alpha_0}\right)^m x^{qm}$$

form a fundamental set of Frobenius solutions of

$$\alpha_0 x^2 y'' + \beta_0 x y' + (\gamma_0 + \gamma_q x^q) y = 0.$$

60. (a) Suppose  $\alpha_0, \alpha_1,$  and  $\alpha_2$  are real numbers with  $\alpha_0 \neq 0$ , and  $\{a_n\}_{n=0}^{\infty}$  is defined by

$$\alpha_0 a_1 + \alpha_1 a_0 = 0$$

and

$$\alpha_0 a_n + \alpha_1 a_{n-1} + \alpha_2 a_{n-2} = 0, \quad n \geq 2.$$

Show that

$$(\alpha_0 + \alpha_1 x + \alpha_2 x^2) \sum_{n=0}^{\infty} a_n x^n = \alpha_0 a_0,$$

and infer that

$$\sum_{n=0}^{\infty} a_n x^n = \frac{\alpha_0 a_0}{\alpha_0 + \alpha_1 x + \alpha_2 x^2}.$$

(b) With  $\alpha_0, \alpha_1,$  and  $\alpha_2$  as in (a), consider the equation

$$x^2(\alpha_0 + \alpha_1 x + \alpha_2 x^2)y'' + x(\beta_0 + \beta_1 x + \beta_2 x^2)y' + (\gamma_0 + \gamma_1 x + \gamma_2 x^2)y = 0, \quad (7.5.1)$$

and define

$$p_j(r) = \alpha_j r(r-1) + \beta_j r + \gamma_j, \quad j = 0, 1, 2.$$

Suppose

$$\frac{p_1(r-1)}{p_0(r)} = \frac{\alpha_1}{\alpha_0}, \quad \frac{p_2(r-2)}{p_0(r)} = \frac{\alpha_2}{\alpha_0},$$

and

$$p_0(r) = \alpha_0(r-r_1)(r-r_2),$$

where  $r_1 > r_2$ . Show that

$$y_1 = \frac{x^{r_1}}{\alpha_0 + \alpha_1 x + \alpha_2 x^2} \quad \text{and} \quad y_2 = \frac{x^{r_2}}{\alpha_0 + \alpha_1 x + \alpha_2 x^2}$$

form a fundamental set of Frobenius solutions of (7.5.1) on any interval  $(0, \rho)$  on which  $\alpha_0 + \alpha_1 x + \alpha_2 x^2$  has no zeros.

In Exercises 61–68 use the method suggested by Exercise 60 to find the general solution on some interval  $(0, \rho)$ .

61.  $2x^2(1+x)y'' - x(1-3x)y' + y = 0$

62.  $6x^2(1 + 2x^2)y'' + x(1 + 50x^2)y' + (1 + 30x^2)y = 0$   
 63.  $28x^2(1 - 3x)y'' - 7x(5 + 9x)y' + 7(2 + 9x)y = 0$   
 64.  $9x^2(5 + x)y'' + 9x(5 + 3x)y' - (5 - 8x)y = 0$   
 65.  $8x^2(2 - x^2)y'' + 2x(10 - 21x^2)y' - (2 + 35x^2)y = 0$   
 66.  $4x^2(1 + 3x + x^2)y'' - 4x(1 - 3x - 3x^2)y' + 3(1 - x + x^2)y = 0$   
 67.  $3x^2(1 + x)^2y'' - x(1 - 10x - 11x^2)y' + (1 + 5x^2)y = 0$   
 68.  $4x^2(3 + 2x + x^2)y'' - x(3 - 14x - 15x^2)y' + (3 + 7x^2)y = 0$

## 7.6 THE METHOD OF FROBENIUS II

In this section we discuss a method for finding two linearly independent Frobenius solutions of a homogeneous linear second order equation near a regular singular point in the case where the indicial equation has a repeated real root. As in the preceding section, we consider equations that can be written as

$$x^2(\alpha_0 + \alpha_1x + \alpha_2x^2)y'' + x(\beta_0 + \beta_1x + \beta_2x^2)y' + (\gamma_0 + \gamma_1x + \gamma_2x^2)y = 0 \quad (7.6.1)$$

where  $\alpha_0 \neq 0$ . We assume that the indicial equation  $p_0(r) = 0$  has a repeated real root  $r_1$ . In this case Theorem 7.5.3 implies that (7.6.1) has one solution of the form

$$y_1 = x^{r_1} \sum_{n=0}^{\infty} a_n x^n,$$

but does not provide a second solution  $y_2$  such that  $\{y_1, y_2\}$  is a fundamental set of solutions. The following extension of Theorem 7.5.2 provides a way to find a second solution.

**Theorem 7.6.1** *Let*

$$Ly = x^2(\alpha_0 + \alpha_1x + \alpha_2x^2)y'' + x(\beta_0 + \beta_1x + \beta_2x^2)y' + (\gamma_0 + \gamma_1x + \gamma_2x^2)y, \quad (7.6.2)$$

where  $\alpha_0 \neq 0$  and define

$$\begin{aligned} p_0(r) &= \alpha_0 r(r-1) + \beta_0 r + \gamma_0, \\ p_1(r) &= \alpha_1 r(r-1) + \beta_1 r + \gamma_1, \\ p_2(r) &= \alpha_2 r(r-1) + \beta_2 r + \gamma_2. \end{aligned}$$

Suppose  $r$  is a real number such that  $p_0(n+r)$  is nonzero for all positive integers  $n$ , and define

$$\begin{aligned} a_0(r) &= 1, \\ a_1(r) &= -\frac{p_1(r)}{p_0(r+1)}, \\ a_n(r) &= -\frac{p_1(n+r-1)a_{n-1}(r) + p_2(n+r-2)a_{n-2}(r)}{p_0(n+r)}, \quad n \geq 2. \end{aligned}$$

Then the Frobenius series

$$y(x, r) = x^r \sum_{n=0}^{\infty} a_n(r) x^n \quad (7.6.3)$$

satisfies

$$Ly(x, r) = p_0(r)x^r. \quad (7.6.4)$$

Moreover,

$$\frac{\partial y}{\partial r}(x, r) = y(x, r) \ln x + x^r \sum_{n=1}^{\infty} a'_n(r)x^n, \quad (7.6.5)$$

and

$$L\left(\frac{\partial y}{\partial r}(x, r)\right) = p'_0(r)x^r + x^r p_0(r) \ln x. \quad (7.6.6)$$

**Proof** Theorem 7.5.2 implies (7.6.4). Differentiating formally with respect to  $r$  in (7.6.3) yields

$$\begin{aligned} \frac{\partial y}{\partial r}(x, r) &= \frac{\partial}{\partial r}(x^r) \sum_{n=0}^{\infty} a_n(r)x^n + x^r \sum_{n=1}^{\infty} a'_n(r)x^n \\ &= x^r \ln x \sum_{n=0}^{\infty} a_n(r)x^n + x^r \sum_{n=1}^{\infty} a'_n(r)x^n \\ &= y(x, r) \ln x + x^r \sum_{n=1}^{\infty} a'_n(r)x^n, \end{aligned}$$

which proves (7.6.5).

To prove that  $\partial y(x, r)/\partial r$  satisfies (7.6.6), we view  $y$  in (7.6.2) as a function  $y = y(x, r)$  of two variables, where the prime indicates partial differentiation with respect to  $x$ ; thus,

$$y' = y'(x, r) = \frac{\partial y}{\partial x}(x, r) \quad \text{and} \quad y'' = y''(x, r) = \frac{\partial^2 y}{\partial x^2}(x, r).$$

With this notation we can use (7.6.2) to rewrite (7.6.4) as

$$x^2 q_0(x) \frac{\partial^2 y}{\partial x^2}(x, r) + x q_1(x) \frac{\partial y}{\partial x}(x, r) + q_2(x) y(x, r) = p_0(r) x^r, \quad (7.6.7)$$

where

$$\begin{aligned} q_0(x) &= \alpha_0 + \alpha_1 x + \alpha_2 x^2, \\ q_1(x) &= \beta_0 + \beta_1 x + \beta_2 x^2, \\ q_2(x) &= \gamma_0 + \gamma_1 x + \gamma_2 x^2. \end{aligned}$$

Differentiating both sides of (7.6.7) with respect to  $r$  yields

$$x^2 q_0(x) \frac{\partial^3 y}{\partial r \partial x^2}(x, r) + x q_1(x) \frac{\partial^2 y}{\partial r \partial x}(x, r) + q_2(x) \frac{\partial y}{\partial r}(x, r) = p'_0(r) x^r + p_0(r) x^r \ln x.$$

By changing the order of differentiation in the first two terms on the left we can rewrite this as

$$x^2 q_0(x) \frac{\partial^3 y}{\partial x^2 \partial r}(x, r) + x q_1(x) \frac{\partial^2 y}{\partial x \partial r}(x, r) + q_2(x) \frac{\partial y}{\partial r}(x, r) = p'_0(r) x^r + p_0(r) x^r \ln x,$$

or

$$x^2 q_0(x) \frac{\partial^2}{\partial x^2} \left( \frac{\partial y}{\partial r}(x, r) \right) + x q_1(x) \frac{\partial}{\partial r} \left( \frac{\partial y}{\partial x}(x, r) \right) + q_2(x) \frac{\partial y}{\partial r}(x, r) = p_0'(r)x^r + p_0(r)x^r \ln x,$$

which is equivalent to (7.6.6).

**Theorem 7.6.2** *Let  $L$  be as in Theorem 7.6.1 and suppose the indicial equation  $p_0(r) = 0$  has a repeated real root  $r_1$ . Then*

$$y_1(x) = y(x, r_1) = x^{r_1} \sum_{n=0}^{\infty} a_n(r_1)x^n$$

and

$$y_2(x) = \frac{\partial y}{\partial r}(x, r_1) = y_1(x) \ln x + x^{r_1} \sum_{n=1}^{\infty} a_n'(r_1)x^n \quad (7.6.8)$$

form a fundamental set of solutions of  $Ly = 0$ .

**Proof** Since  $r_1$  is a repeated root of  $p_0(r) = 0$ , the indicial polynomial can be factored as

$$p_0(r) = \alpha_0(r - r_1)^2,$$

so

$$p_0(n + r_1) = \alpha_0 n^2,$$

which is nonzero if  $n > 0$ . Therefore the assumptions of Theorem 7.6.1 hold with  $r = r_1$ , and (7.6.4) implies that  $Ly_1 = p_0(r_1)x^{r_1} = 0$ . Since

$$p_0'(r) = 2\alpha_0(r - r_1)$$

it follows that  $p_0'(r_1) = 0$ , so (7.6.6) implies that

$$Ly_2 = p_0'(r_1)x^{r_1} + x^{r_1}p_0(r_1) \ln x = 0.$$

This proves that  $y_1$  and  $y_2$  are both solutions of  $Ly = 0$ . We leave the proof that  $\{y_1, y_2\}$  is a fundamental set as an exercise (Exercise 53).

**Example 7.6.1** Find a fundamental set of solutions of

$$x^2(1 - 2x + x^2)y'' - x(3 + x)y' + (4 + x)y = 0. \quad (7.6.9)$$

Compute just the terms involving  $x^{n+r_1}$ , where  $0 \leq n \leq 4$  and  $r_1$  is the root of the indicial equation.

**Solution** For the given equation, the polynomials defined in Theorem 7.6.1 are

$$\begin{aligned} p_0(r) &= r(r-1) - 3r + 4 = (r-2)^2, \\ p_1(r) &= -2r(r-1) - r + 1 = -(r-1)(2r+1), \\ p_2(r) &= r(r-1). \end{aligned}$$

Since  $r_1 = 2$  is a repeated root of the indicial polynomial  $p_0$ , Theorem 7.6.2 implies that

$$y_1 = x^2 \sum_{n=0}^{\infty} a_n(2)x^n \quad \text{and} \quad y_2 = y_1 \ln x + x^2 \sum_{n=1}^{\infty} a_n'(2)x^n \quad (7.6.10)$$

form a fundamental set of Frobenius solutions of (7.6.9). To find the coefficients in these series, we use the recurrence formulas from Theorem 7.6.1:

$$\begin{aligned}
 a_0(r) &= 1, \\
 a_1(r) &= -\frac{p_1(r)}{p_0(r+1)} = -\frac{(r-1)(2r+1)}{(r-1)^2} = \frac{2r+1}{r-1}, \\
 a_n(r) &= -\frac{p_1(n+r-1)a_{n-1}(r) + p_2(n+r-2)a_{n-2}(r)}{p_0(n+r)} \\
 &= \frac{(n+r-2)[(2n+2r-1)a_{n-1}(r) - (n+r-3)a_{n-2}(r)]}{(n+r-2)^2} \\
 &= \frac{(2n+2r-1)}{(n+r-2)}a_{n-1}(r) - \frac{(n+r-3)}{(n+r-2)}a_{n-2}(r), \quad n \geq 2.
 \end{aligned} \tag{7.6.11}$$

Differentiating yields

$$\begin{aligned}
 a'_1(r) &= -\frac{3}{(r-1)^2}, \\
 a'_n(r) &= \frac{2n+2r-1}{n+r-2}a'_{n-1}(r) - \frac{n+r-3}{n+r-2}a'_{n-2}(r) \\
 &\quad - \frac{3}{(n+r-2)^2}a_{n-1}(r) - \frac{1}{(n+r-2)^2}a_{n-2}(r), \quad n \geq 2.
 \end{aligned} \tag{7.6.12}$$

Setting  $r = 2$  in (7.6.11) and (7.6.12) yields

$$\begin{aligned}
 a_0(2) &= 1, \\
 a_1(2) &= 5, \\
 a_n(2) &= \frac{(2n+3)}{n}a_{n-1}(2) - \frac{(n-1)}{n}a_{n-2}(2), \quad n \geq 2
 \end{aligned} \tag{7.6.13}$$

and

$$\begin{aligned}
 a'_1(2) &= -3, \\
 a'_n(2) &= \frac{2n+3}{n}a'_{n-1}(2) - \frac{n-1}{n}a'_{n-2}(2) - \frac{3}{n^2}a_{n-1}(2) - \frac{1}{n^2}a_{n-2}(2), \quad n \geq 2.
 \end{aligned} \tag{7.6.14}$$

Computing recursively with (7.6.13) and (7.6.14) yields

$$a_0(2) = 1, a_1(2) = 5, a_2(2) = 17, a_3(2) = \frac{143}{3}, a_4(2) = \frac{355}{3},$$

and

$$a'_1(2) = -3, a'_2(2) = -\frac{29}{2}, a'_3(2) = -\frac{859}{18}, a'_4(2) = -\frac{4693}{36}.$$

Substituting these coefficients into (7.6.10) yields

$$y_1 = x^2 \left( 1 + 5x + 17x^2 + \frac{143}{3}x^3 + \frac{355}{3}x^4 + \dots \right)$$

and

$$y_2 = y_1 \ln x - x^3 \left( 3 + \frac{29}{2}x + \frac{859}{18}x^2 + \frac{4693}{36}x^3 + \dots \right). \blacksquare$$

Since the recurrence formula (7.6.11) involves three terms, it's not possible to obtain a simple explicit formula for the coefficients in the Frobenius solutions of (7.6.9). However, as we saw in the preceding sections, the recurrence formula for  $\{a_n(r)\}$  involves only two terms if either  $\alpha_1 = \beta_1 = \gamma_1 = 0$  or  $\alpha_2 = \beta_2 = \gamma_2 = 0$  in (7.6.1). In this case, it's often possible to find explicit formulas for the coefficients. The next two examples illustrate this.

**Example 7.6.2** Find a fundamental set of Frobenius solutions of

$$2x^2(2+x)y'' + 5x^2y' + (1+x)y = 0. \quad (7.6.15)$$

Give explicit formulas for the coefficients in the solutions.

**Solution** For the given equation, the polynomials defined in Theorem 7.6.1 are

$$\begin{aligned} p_0(r) &= 4r(r-1) + 1 = (2r-1)^2, \\ p_1(r) &= 2r(r-1) + 5r + 1 = (r+1)(2r+1), \\ p_2(r) &= 0. \end{aligned}$$

Since  $r_1 = 1/2$  is a repeated zero of the indicial polynomial  $p_0$ , Theorem 7.6.2 implies that

$$y_1 = x^{1/2} \sum_{n=0}^{\infty} a_n(1/2)x^n \quad (7.6.16)$$

and

$$y_2 = y_1 \ln x + x^{1/2} \sum_{n=1}^{\infty} a'_n(1/2)x^n \quad (7.6.17)$$

form a fundamental set of Frobenius solutions of (7.6.15). Since  $p_2 \equiv 0$ , the recurrence formulas in Theorem 7.6.1 reduce to

$$\begin{aligned} a_0(r) &= 1, \\ a_n(r) &= -\frac{p_1(n+r-1)}{p_0(n+r)} a_{n-1}(r), \\ &= -\frac{(n+r)(2n+2r-1)}{(2n+2r-1)^2} a_{n-1}(r), \\ &= -\frac{n+r}{2n+2r-1} a_{n-1}(r), \quad n \geq 0. \end{aligned}$$

We leave it to you to show that

$$a_n(r) = (-1)^n \prod_{j=1}^n \frac{j+r}{2j+2r-1}, \quad n \geq 0. \quad (7.6.18)$$

Setting  $r = 1/2$  yields

$$\begin{aligned} a_n(1/2) &= (-1)^n \prod_{j=1}^n \frac{j+1/2}{2j} = (-1)^n \prod_{j=1}^n \frac{2j+1}{4j}, \\ &= \frac{(-1)^n \prod_{j=1}^n (2j+1)}{4^n n!}, \quad n \geq 0. \end{aligned} \quad (7.6.19)$$

Substituting this into (7.6.16) yields

$$y_1 = x^{1/2} \sum_{n=0}^{\infty} \frac{(-1)^n \prod_{j=1}^n (2j+1)}{4^n n!} x^n.$$

To obtain  $y_2$  in (7.6.17), we must compute  $a'_n(1/2)$  for  $n = 1, 2, \dots$ . We'll do this by logarithmic differentiation. From (7.6.18),

$$|a_n(r)| = \prod_{j=1}^n \frac{|j+r|}{|2j+2r-1|}, \quad n \geq 1.$$

Therefore

$$\ln |a_n(r)| = \sum_{j=1}^n (\ln |j+r| - \ln |2j+2r-1|).$$

Differentiating with respect to  $r$  yields

$$\frac{a'_n(r)}{a_n(r)} = \sum_{j=1}^n \left( \frac{1}{j+r} - \frac{2}{2j+2r-1} \right).$$

Therefore

$$a'_n(r) = a_n(r) \sum_{j=1}^n \left( \frac{1}{j+r} - \frac{2}{2j+2r-1} \right).$$

Setting  $r = 1/2$  here and recalling (7.6.19) yields

$$a'_n(1/2) = \frac{(-1)^n \prod_{j=1}^n (2j+1)}{4^n n!} \left( \sum_{j=1}^n \frac{1}{j+1/2} - \sum_{j=1}^n \frac{1}{j} \right). \quad (7.6.20)$$

Since

$$\frac{1}{j+1/2} - \frac{1}{j} = \frac{j-j-1/2}{j(j+1/2)} = -\frac{1}{j(2j+1)},$$

(7.6.20) can be rewritten as

$$a'_n(1/2) = -\frac{(-1)^n \prod_{j=1}^n (2j+1)}{4^n n!} \sum_{j=1}^n \frac{1}{j(2j+1)}.$$

Therefore, from (7.6.17),

$$y_2 = y_1 \ln x - x^{1/2} \sum_{n=1}^{\infty} \frac{(-1)^n \prod_{j=1}^n (2j+1)}{4^n n!} \left( \sum_{j=1}^n \frac{1}{j(2j+1)} \right) x^n.$$

**Example 7.6.3** Find a fundamental set of Frobenius solutions of

$$x^2(2-x^2)y'' - 2x(1+2x^2)y' + (2-2x^2)y = 0. \quad (7.6.21)$$

Give explicit formulas for the coefficients in the solutions.



**Solution** For (7.6.21), the polynomials defined in Theorem 7.6.1 are

$$\begin{aligned} p_0(r) &= 2r(r-1) - 2r + 2 = 2(r-1)^2, \\ p_1(r) &= 0, \\ p_2(r) &= -r(r-1) - 4r - 2 = -(r+1)(r+2). \end{aligned}$$

As in Section 7.5, since  $p_1 \equiv 0$ , the recurrence formulas of Theorem 7.6.1 imply that  $a_n(r) = 0$  if  $n$  is odd, and

$$\begin{aligned} a_0(r) &= 1, \\ a_{2m}(r) &= -\frac{p_2(2m+r-2)}{p_0(2m+r)} a_{2m-2}(r) \\ &= \frac{(2m+r-1)(2m+r)}{2(2m+r-1)^2} a_{2m-2}(r) \\ &= \frac{2m+r}{2(2m+r-1)} a_{2m-2}(r), \quad m \geq 1. \end{aligned}$$

Since  $r_1 = 1$  is a repeated root of the indicial polynomial  $p_0$ , Theorem 7.6.2 implies that

$$y_1 = x \sum_{m=0}^{\infty} a_{2m}(1)x^{2m} \quad (7.6.22)$$

and

$$y_2 = y_1 \ln x + x \sum_{m=1}^{\infty} a'_{2m}(1)x^{2m} \quad (7.6.23)$$

form a fundamental set of Frobenius solutions of (7.6.21). We leave it to you to show that

$$a_{2m}(r) = \frac{1}{2^m} \prod_{j=1}^m \frac{2j+r}{2j+r-1}. \quad (7.6.24)$$

Setting  $r = 1$  yields

$$a_{2m}(1) = \frac{1}{2^m} \prod_{j=1}^m \frac{2j+1}{2j} = \frac{\prod_{j=1}^m (2j+1)}{4^m m!}, \quad (7.6.25)$$

and substituting this into (7.6.22) yields

$$y_1 = x \sum_{m=0}^{\infty} \frac{\prod_{j=1}^m (2j+1)}{4^m m!} x^{2m}.$$

To obtain  $y_2$  in (7.6.23), we must compute  $a'_{2m}(1)$  for  $m = 1, 2, \dots$ . Again we use logarithmic differentiation. From (7.6.24),

$$|a_{2m}(r)| = \frac{1}{2^m} \prod_{j=1}^m \frac{|2j+r|}{|2j+r-1|}.$$

Taking logarithms yields

$$\ln |a_{2m}(r)| = -m \ln 2 + \sum_{j=1}^m (\ln |2j+r| - \ln |2j+r-1|).$$

Differentiating with respect to  $r$  yields

$$\frac{a'_{2m}(r)}{a_{2m}(r)} = \sum_{j=1}^m \left( \frac{1}{2j+r} - \frac{1}{2j+r-1} \right).$$

Therefore

$$a'_{2m}(r) = a_{2m}(r) \sum_{j=1}^m \left( \frac{1}{2j+r} - \frac{1}{2j+r-1} \right).$$

Setting  $r = 1$  and recalling (7.6.25) yields

$$a'_{2m}(1) = \frac{\prod_{j=1}^m (2j+1)}{4^m m!} \sum_{j=1}^m \left( \frac{1}{2j+1} - \frac{1}{2j} \right). \quad (7.6.26)$$

Since

$$\frac{1}{2j+1} - \frac{1}{2j} = -\frac{1}{2j(2j+1)},$$

(7.6.26) can be rewritten as

$$a'_{2m}(1) = -\frac{\prod_{j=1}^m (2j+1)}{2 \cdot 4^m m!} \sum_{j=1}^m \frac{1}{j(2j+1)}.$$

Substituting this into (7.6.23) yields

$$y_2 = y_1 \ln x - \frac{x}{2} \sum_{m=1}^{\infty} \frac{\prod_{j=1}^m (2j+1)}{4^m m!} \left( \sum_{j=1}^m \frac{1}{j(2j+1)} \right) x^{2m}. \blacksquare$$

If the solution  $y_1 = y(x, r_1)$  of  $Ly = 0$  reduces to a finite sum, then there's a difficulty in using logarithmic differentiation to obtain the coefficients  $\{a'_n(r_1)\}$  in the second solution. The next example illustrates this difficulty and shows how to overcome it.

**Example 7.6.4** Find a fundamental set of Frobenius solutions of

$$x^2 y'' - x(5-x)y' + (9-4x)y = 0. \quad (7.6.27)$$

Give explicit formulas for the coefficients in the solutions.

**Solution** For (7.6.27) the polynomials defined in Theorem 7.6.1 are

$$\begin{aligned} p_0(r) &= r(r-1) - 5r + 9 = (r-3)^2, \\ p_1(r) &= r - 4, \\ p_2(r) &= 0. \end{aligned}$$

Since  $r_1 = 3$  is a repeated zero of the indicial polynomial  $p_0$ , Theorem 7.6.2 implies that

$$y_1 = x^3 \sum_{n=0}^{\infty} a_n(3) x^n \quad (7.6.28)$$

and

$$y_2 = y_1 \ln x + x^3 \sum_{n=1}^{\infty} a'_n(3)x^n \quad (7.6.29)$$

are linearly independent Frobenius solutions of (7.6.27). To find the coefficients in (7.6.28) we use the recurrence formulas

$$\begin{aligned} a_0(r) &= 1, \\ a_n(r) &= -\frac{p_1(n+r-1)}{p_0(n+r)}a_{n-1}(r) \\ &= -\frac{n+r-5}{(n+r-3)^2}a_{n-1}(r), \quad n \geq 1. \end{aligned}$$

We leave it to you to show that

$$a_n(r) = (-1)^n \prod_{j=1}^n \frac{j+r-5}{(j+r-3)^2}. \quad (7.6.30)$$

Setting  $r = 3$  here yields

$$a_n(3) = (-1)^n \prod_{j=1}^n \frac{j-2}{j^2},$$

so  $a_1(3) = 1$  and  $a_n(3) = 0$  if  $n \geq 2$ . Substituting these coefficients into (7.6.28) yields

$$y_1 = x^3(1+x).$$

To obtain  $y_2$  in (7.6.29) we must compute  $a'_n(3)$  for  $n = 1, 2, \dots$ . Let's first try logarithmic differentiation. From (7.6.30),

$$|a_n(r)| = \prod_{j=1}^n \frac{|j+r-5|}{|j+r-3|^2}, \quad n \geq 1,$$

so

$$\ln |a_n(r)| = \sum_{j=1}^n (\ln |j+r-5| - 2 \ln |j+r-3|).$$

Differentiating with respect to  $r$  yields

$$\frac{a'_n(r)}{a_n(r)} = \sum_{j=1}^n \left( \frac{1}{j+r-5} - \frac{2}{j+r-3} \right).$$

Therefore

$$a'_n(r) = a_n(r) \sum_{j=1}^n \left( \frac{1}{j+r-5} - \frac{2}{j+r-3} \right). \quad (7.6.31)$$

However, we can't simply set  $r = 3$  here if  $n \geq 2$ , since the bracketed expression in the sum corresponding to  $j = 2$  contains the term  $1/(r-3)$ . In fact, since  $a_n(3) = 0$  for  $n \geq 2$ , the formula (7.6.31) for  $a'_n(r)$  is actually an indeterminate form at  $r = 3$ .

We overcome this difficulty as follows. From (7.6.30) with  $n = 1$ ,

$$a_1(r) = -\frac{r-4}{(r-2)^2}.$$

Therefore

$$a'_1(r) = \frac{r-6}{(r-2)^3},$$

so

$$a'_1(3) = -3. \quad (7.6.32)$$

From (7.6.30) with  $n \geq 2$ ,

$$a_n(r) = (-1)^n(r-4)(r-3) \frac{\prod_{j=3}^n(j+r-5)}{\prod_{j=1}^n(j+r-3)^2} = (r-3)c_n(r),$$

where

$$c_n(r) = (-1)^n(r-4) \frac{\prod_{j=3}^n(j+r-5)}{\prod_{j=1}^n(j+r-3)^2}, \quad n \geq 2.$$

Therefore

$$a'_n(r) = c_n(r) + (r-3)c'_n(r), \quad n \geq 2,$$

which implies that  $a'_n(3) = c_n(3)$  if  $n \geq 3$ . We leave it to you to verify that

$$a'_n(3) = c_n(3) = \frac{(-1)^{n+1}}{n(n-1)n!}, \quad n \geq 2.$$

Substituting this and (7.6.32) into (7.6.29) yields

$$y_2 = x^3(1+x) \ln x - 3x^4 - x^3 \sum_{n=2}^{\infty} \frac{(-1)^n}{n(n-1)n!} x^n.$$

## 7.6 Exercises

In Exercises 1–11 find a fundamental set of Frobenius solutions. Compute the terms involving  $x^{n+r_1}$ , where  $0 \leq n \leq N$  ( $N$  at least 7) and  $r_1$  is the root of the indicial equation. Optionally, write a computer program to implement the applicable recurrence formulas and take  $N > 7$ .

1.   $x^2y'' - x(1-x)y' + (1-x^2)y = 0$
2.   $x^2(1+x+2x^2)y' + x(3+6x+7x^2)y' + (1+6x-3x^2)y = 0$
3.   $x^2(1+2x+x^2)y'' + x(1+3x+4x^2)y' - x(1-2x)y = 0$
4.   $4x^2(1+x+x^2)y'' + 12x^2(1+x)y' + (1+3x+3x^2)y = 0$
5.   $x^2(1+x+x^2)y'' - x(1-4x-2x^2)y' + y = 0$
6.   $9x^2y'' + 3x(5+3x-2x^2)y' + (1+12x-14x^2)y = 0$
7.   $x^2y'' + x(1+x+x^2)y' + x(2-x)y = 0$
8.   $x^2(1+2x)y'' + x(5+14x+3x^2)y' + (4+18x+12x^2)y = 0$
9.   $4x^2y'' + 2x(4+x+x^2)y' + (1+5x+3x^2)y = 0$
10.   $16x^2y'' + 4x(6+x+2x^2)y' + (1+5x+18x^2)y = 0$
11.   $9x^2(1+x)y'' + 3x(5+11x-x^2)y' + (1+16x-7x^2)y = 0$

In Exercises 12–22 find a fundamental set of Frobenius solutions. Give explicit formulas for the coefficients.

12.  $4x^2y'' + (1 + 4x)y = 0$
13.  $36x^2(1 - 2x)y'' + 24x(1 - 9x)y' + (1 - 70x)y = 0$
14.  $x^2(1 + x)y'' - x(3 - x)y' + 4y = 0$
15.  $x^2(1 - 2x)y'' - x(5 - 4x)y' + (9 - 4x)y = 0$
16.  $25x^2y'' + x(15 + x)y' + (1 + x)y = 0$
17.  $2x^2(2 + x)y'' + x^2y' + (1 - x)y = 0$
18.  $x^2(9 + 4x)y'' + 3xy' + (1 + x)y = 0$
19.  $x^2y'' - x(3 - 2x)y' + (4 + 3x)y = 0$
20.  $x^2(1 - 4x)y'' + 3x(1 - 6x)y' + (1 - 12x)y = 0$
21.  $x^2(1 + 2x)y'' + x(3 + 5x)y' + (1 - 2x)y = 0$
22.  $2x^2(1 + x)y'' - x(6 - x)y' + (8 - x)y = 0$

In Exercises 23–27 find a fundamental set of Frobenius solutions. Compute the terms involving  $x^{n+r_1}$ , where  $0 \leq n \leq N$  ( $N$  at least 7) and  $r_1$  is the root of the indicial equation. Optionally, write a computer program to implement the applicable recurrence formulas and take  $N > 7$ .

23.   $x^2(1 + 2x)y'' + x(5 + 9x)y' + (4 + 3x)y = 0$
24.   $x^2(1 - 2x)y'' - x(5 + 4x)y' + (9 + 4x)y = 0$
25.   $x^2(1 + 4x)y'' - x(1 - 4x)y' + (1 + x)y = 0$
26.   $x^2(1 + x)y'' + x(1 + 2x)y' + xy = 0$
27.   $x^2(1 - x)y'' + x(7 + x)y' + (9 - x)y = 0$

In Exercises 28–38 find a fundamental set of Frobenius solutions. Give explicit formulas for the coefficients.

28.  $x^2y'' - x(1 - x^2)y' + (1 + x^2)y = 0$
29.  $x^2(1 + x^2)y'' - 3x(1 - x^2)y' + 4y = 0$
30.  $4x^2y'' + 2x^3y' + (1 + 3x^2)y = 0$
31.  $x^2(1 + x^2)y'' - x(1 - 2x^2)y' + y = 0$
32.  $2x^2(2 + x^2)y'' + 7x^3y' + (1 + 3x^2)y = 0$
33.  $x^2(1 + x^2)y'' - x(1 - 4x^2)y' + (1 + 2x^2)y = 0$
34.  $4x^2(4 + x^2)y'' + 3x(8 + 3x^2)y' + (1 - 9x^2)y = 0$
35.  $3x^2(3 + x^2)y'' + x(3 + 11x^2)y' + (1 + 5x^2)y = 0$
36.  $4x^2(1 + 4x^2)y'' + 32x^3y' + y = 0$
37.  $9x^2y'' - 3x(7 - 2x^2)y' + (25 + 2x^2)y = 0$
38.  $x^2(1 + 2x^2)y'' + x(3 + 7x^2)y' + (1 - 3x^2)y = 0$

In Exercises 39–43 find a fundamental set of Frobenius solutions. Compute the terms involving  $x^{2m+r_1}$ , where  $0 \leq m \leq M$  ( $M$  at least 3) and  $r_1$  is the root of the indicial equation. Optionally, write a computer program to implement the applicable recurrence formulas and take  $M > 3$ .

39.  $\boxed{C}$   $x^2(1+x^2)y'' + x(3+8x^2)y' + (1+12x^2)y$   
 40.  $\boxed{C}$   $x^2y'' - x(1-x^2)y' + (1+x^2)y = 0$   
 41.  $\boxed{C}$   $x^2(1-2x^2)y'' + x(5-9x^2)y' + (4-3x^2)y = 0$   
 42.  $\boxed{C}$   $x^2(2+x^2)y'' + x(14-x^2)y' + 2(9+x^2)y = 0$   
 43.  $\boxed{C}$   $x^2(1+x^2)y'' + x(3+7x^2)y' + (1+8x^2)y = 0$

In Exercises 44–52 find a fundamental set of Frobenius solutions. Give explicit formulas for the coefficients.

44.  $x^2(1-2x)y'' + 3xy' + (1+4x)y = 0$   
 45.  $x(1+x)y'' + (1-x)y' + y = 0$   
 46.  $x^2(1-x)y'' + x(3-2x)y' + (1+2x)y = 0$   
 47.  $4x^2(1+x)y'' - 4x^2y' + (1-5x)y = 0$   
 48.  $x^2(1-x)y'' - x(3-5x)y' + (4-5x)y = 0$   
 49.  $x^2(1+x^2)y'' - x(1+9x^2)y' + (1+25x^2)y = 0$   
 50.  $9x^2y'' + 3x(1-x^2)y' + (1+7x^2)y = 0$   
 51.  $x(1+x^2)y'' + (1-x^2)y' - 8xy = 0$   
 52.  $4x^2y'' + 2x(4-x^2)y' + (1+7x^2)y = 0$   
 53. Under the assumptions of Theorem 7.6.2, suppose the power series

$$\sum_{n=0}^{\infty} a_n(r_1)x^n \quad \text{and} \quad \sum_{n=1}^{\infty} a'_n(r_1)x^n$$

converge on  $(-\rho, \rho)$ .

(a) Show that

$$y_1 = x^{r_1} \sum_{n=0}^{\infty} a_n(r_1)x^n \quad \text{and} \quad y_2 = y_1 \ln x + x^{r_1} \sum_{n=1}^{\infty} a'_n(r_1)x^n$$

are linearly independent on  $(0, \rho)$ . HINT: Show that if  $c_1$  and  $c_2$  are constants such that  $c_1y_1 + c_2y_2 \equiv 0$  on  $(0, \rho)$ , then

$$(c_1 + c_2 \ln x) \sum_{n=0}^{\infty} a_n(r_1)x^n + c_2 \sum_{n=1}^{\infty} a'_n(r_1)x^n = 0, \quad 0 < x < \rho.$$

Then let  $x \rightarrow 0+$  to conclude that  $c_2 = 0$ .

(b) Use the result of (a) to complete the proof of Theorem 7.6.2.

54. Let

$$Ly = x^2(\alpha_0 + \alpha_1x)y'' + x(\beta_0 + \beta_1x)y' + (\gamma_0 + \gamma_1x)y$$

and define

$$p_0(r) = \alpha_0 r(r-1) + \beta_0 r + \gamma_0 \quad \text{and} \quad p_1(r) = \alpha_1 r(r-1) + \beta_1 r + \gamma_1.$$

Theorem 7.6.1 and Exercise 7.5.55(a) imply that if

$$y(x, r) = x^r \sum_{n=0}^{\infty} a_n(r) x^n$$

where

$$a_n(r) = (-1)^n \prod_{j=1}^n \frac{p_1(j+r-1)}{p_0(j+r)},$$

then

$$Ly(x, r) = p_0(r)x^r.$$

Now suppose  $p_0(r) = \alpha_0(r-r_1)^2$  and  $p_1(k+r_1) \neq 0$  if  $k$  is a nonnegative integer.

(a) Show that  $Ly = 0$  has the solution

$$y_1 = x^{r_1} \sum_{n=0}^{\infty} a_n(r_1) x^n,$$

where

$$a_n(r_1) = \frac{(-1)^n}{\alpha_0^n (n!)^2} \prod_{j=1}^n p_1(j+r_1-1).$$

(b) Show that  $Ly = 0$  has the second solution

$$y_2 = y_1 \ln x + x^{r_1} \sum_{n=1}^{\infty} a_n(r_1) J_n x^n,$$

where

$$J_n = \sum_{j=1}^n \frac{p_1'(j+r_1-1)}{p_1(j+r_1-1)} - 2 \sum_{j=1}^n \frac{1}{j}.$$

(c) Conclude from (a) and (b) that if  $\gamma_1 \neq 0$  then

$$y_1 = x^{r_1} \sum_{n=0}^{\infty} \frac{(-1)^n}{(n!)^2} \left( \frac{\gamma_1}{\alpha_0} \right)^n x^n$$

and

$$y_2 = y_1 \ln x - 2x^{r_1} \sum_{n=1}^{\infty} \frac{(-1)^n}{(n!)^2} \left( \frac{\gamma_1}{\alpha_0} \right)^n \left( \sum_{j=1}^n \frac{1}{j} \right) x^n$$

are solutions of

$$\alpha_0 x^2 y'' + \beta_0 x y' + (\gamma_0 + \gamma_1 x) y = 0.$$

(The conclusion is also valid if  $\gamma_1 = 0$ . Why?)

55. Let

$$Ly = x^2(\alpha_0 + \alpha_q x^q)y'' + x(\beta_0 + \beta_q x^q)y' + (\gamma_0 + \gamma_q x^q)y$$

where  $q$  is a positive integer, and define

$$p_0(r) = \alpha_0 r(r-1) + \beta_0 r + \gamma_0 \quad \text{and} \quad p_q(r) = \alpha_q r(r-1) + \beta_q r + \gamma_q.$$

Suppose

$$p_0(r) = \alpha_0(r - r_1)^2 \quad \text{and} \quad p_q(r) \neq 0.$$

(a) Recall from Exercise 7.5.59 that  $Ly = 0$  has the solution

$$y_1 = x^{r_1} \sum_{m=0}^{\infty} a_{qm}(r_1) x^{qm},$$

where

$$a_{qm}(r_1) = \frac{(-1)^m}{(q^2 \alpha_0)^m (m!)^2} \prod_{j=1}^m p_q(q(j-1) + r_1).$$

(b) Show that  $Ly = 0$  has the second solution

$$y_2 = y_1 \ln x + x^{r_1} \sum_{m=1}^{\infty} a'_{qm}(r_1) J_m x^{qm},$$

where

$$J_m = \sum_{j=1}^m \frac{p'_q(q(j-1) + r_1)}{p_q(q(j-1) + r_1)} - \frac{2}{q} \sum_{j=1}^m \frac{1}{j}.$$

(c) Conclude from (a) and (b) that if  $\gamma_q \neq 0$  then

$$y_1 = x^{r_1} \sum_{m=0}^{\infty} \frac{(-1)^m}{(m!)^2} \left( \frac{\gamma_q}{q^2 \alpha_0} \right)^m x^{qm}$$

and

$$y_2 = y_1 \ln x - \frac{2}{q} x^{r_1} \sum_{m=1}^{\infty} \frac{(-1)^m}{(m!)^2} \left( \frac{\gamma_q}{q^2 \alpha_0} \right)^m \left( \sum_{j=1}^m \frac{1}{j} \right) x^{qm}$$

are solutions of

$$\alpha_0 x^2 y'' + \beta_0 x y' + (\gamma_0 + \gamma_q x^q) y = 0.$$

56. The equation

$$xy'' + y' + xy = 0$$

is *Bessel's equation of order zero*. (See Exercise 53.) Find two linearly independent Frobenius solutions of this equation.

57. Suppose the assumptions of Exercise 7.5.53 hold, except that

$$p_0(r) = \alpha_0(r - r_1)^2.$$

Show that

$$y_1 = \frac{x^{r_1}}{\alpha_0 + \alpha_1 x + \alpha_2 x^2} \quad \text{and} \quad y_2 = \frac{x^{r_1} \ln x}{\alpha_0 + \alpha_1 x + \alpha_2 x^2}$$

are linearly independent Frobenius solutions of

$$x^2(\alpha_0 + \alpha_1 x + \alpha_2 x^2)y'' + x(\beta_0 + \beta_1 x + \beta_2 x^2)y' + (\gamma_0 + \gamma_1 x + \gamma_2 x^2)y = 0$$

on any interval  $(0, \rho)$  on which  $\alpha_0 + \alpha_1 x + \alpha_2 x^2$  has no zeros.



In Exercises 58–65 use the method suggested by Exercise 57 to find the general solution on some interval  $(0, \rho)$ .

58.  $4x^2(1+x)y'' + 8x^2y' + (1+x)y = 0$

59.  $9x^2(3+x)y'' + 3x(3+7x)y' + (3+4x)y = 0$

60.  $x^2(2-x^2)y'' - x(2+3x^2)y' + (2-x^2)y = 0$

61.  $16x^2(1+x^2)y'' + 8x(1+9x^2)y' + (1+49x^2)y = 0$

62.  $x^2(4+3x)y'' - x(4-3x)y' + 4y = 0$

63.  $4x^2(1+3x+x^2)y'' + 8x^2(3+2x)y' + (1+3x+9x^2)y = 0$

64.  $x^2(1-x)^2y'' - x(1+2x-3x^2)y' + (1+x^2)y = 0$

65.  $9x^2(1+x+x^2)y'' + 3x(1+7x+13x^2)y' + (1+4x+25x^2)y = 0$

66. (a) Let  $L$  and  $y(x, r)$  be as in Exercises 57 and 58. Extend Theorem 7.6.1 by showing that

$$L\left(\frac{\partial y}{\partial r}(x, r)\right) = p'_0(r)x^r + x^r p_0(r) \ln x.$$

(b) Show that if

$$p_0(r) = \alpha_0(r - r_1)^2$$

then

$$y_1 = y(x, r_1) \quad \text{and} \quad y_2 = \frac{\partial y}{\partial r}(x, r_1)$$

are solutions of  $Ly = 0$ .

## 7.7 THE METHOD OF FROBENIUS III

In Sections 7.5 and 7.6 we discussed methods for finding Frobenius solutions of a homogeneous linear second order equation near a regular singular point in the case where the indicial equation has a repeated root or distinct real roots that don't differ by an integer. In this section we consider the case where the indicial equation has distinct real roots that differ by an integer. We'll limit our discussion to equations that can be written as

$$x^2(\alpha_0 + \alpha_1 x)y'' + x(\beta_0 + \beta_1 x)y' + (\gamma_0 + \gamma_1 x)y = 0 \quad (7.7.1)$$

or

$$x^2(\alpha_0 + \alpha_2 x^2)y'' + x(\beta_0 + \beta_2 x^2)y' + (\gamma_0 + \gamma_2 x^2)y = 0,$$

where the roots of the indicial equation differ by a positive integer.

We begin with a theorem that provides a fundamental set of solutions of equations of the form (7.7.1).

**Theorem 7.7.1** *Let*

$$Ly = x^2(\alpha_0 + \alpha_1 x)y'' + x(\beta_0 + \beta_1 x)y' + (\gamma_0 + \gamma_1 x)y,$$

where  $\alpha_0 \neq 0$ , and define

$$p_0(r) = \alpha_0 r(r-1) + \beta_0 r + \gamma_0,$$

$$p_1(r) = \alpha_1 r(r-1) + \beta_1 r + \gamma_1.$$

Suppose  $r$  is a real number such that  $p_0(n+r)$  is nonzero for all positive integers  $n$ , and define

$$\begin{aligned} a_0(r) &= 1, \\ a_n(r) &= -\frac{p_1(n+r-1)}{p_0(n+r)}a_{n-1}(r), \quad n \geq 1. \end{aligned} \quad (7.7.2)$$

Let  $r_1$  and  $r_2$  be the roots of the indicial equation  $p_0(r) = 0$ , and suppose  $r_1 = r_2 + k$ , where  $k$  is a positive integer. Then

$$y_1 = x^{r_1} \sum_{n=0}^{\infty} a_n(r_1)x^n$$

is a Frobenius solution of  $Ly = 0$ . Moreover, if we define

$$\begin{aligned} a_0(r_2) &= 1, \\ a_n(r_2) &= -\frac{p_1(n+r_2-1)}{p_0(n+r_2)}a_{n-1}(r_2), \quad 1 \leq n \leq k-1, \end{aligned} \quad (7.7.3)$$

and

$$C = -\frac{p_1(r_1-1)}{k\alpha_0}a_{k-1}(r_2), \quad (7.7.4)$$

then

$$y_2 = x^{r_2} \sum_{n=0}^{k-1} a_n(r_2)x^n + C \left( y_1 \ln x + x^{r_1} \sum_{n=1}^{\infty} a'_n(r_1)x^n \right) \quad (7.7.5)$$

is also a solution of  $Ly = 0$ , and  $\{y_1, y_2\}$  is a fundamental set of solutions.

**Proof** Theorem 7.5.3 implies that  $Ly_1 = 0$ . We'll now show that  $Ly_2 = 0$ . Since  $L$  is a linear operator, this is equivalent to showing that

$$L \left( x^{r_2} \sum_{n=0}^{k-1} a_n(r_2)x^n \right) + CL \left( y_1 \ln x + x^{r_1} \sum_{n=1}^{\infty} a'_n(r_1)x^n \right) = 0. \quad (7.7.6)$$

To verify this, we'll show that

$$L \left( x^{r_2} \sum_{n=0}^{k-1} a_n(r_2)x^n \right) = p_1(r_1-1)a_{k-1}(r_2)x^{r_1} \quad (7.7.7)$$

and

$$L \left( y_1 \ln x + x^{r_1} \sum_{n=1}^{\infty} a'_n(r_1)x^n \right) = k\alpha_0 x^{r_1}. \quad (7.7.8)$$

This will imply that  $Ly_2 = 0$ , since substituting (7.7.7) and (7.7.8) into (7.7.6) and using (7.7.4) yields

$$\begin{aligned} Ly_2 &= [p_1(r_1-1)a_{k-1}(r_2) + Ck\alpha_0]x^{r_1} \\ &= [p_1(r_1-1)a_{k-1}(r_2) - p_1(r_1-1)a_{k-1}(r_2)]x^{r_1} = 0. \end{aligned}$$

We'll prove (7.7.8) first. From Theorem 7.6.1,

$$L \left( y(x, r) \ln x + x^r \sum_{n=1}^{\infty} a'_n(r)x^n \right) = p'_0(r)x^r + x^r p_0(r) \ln x.$$

Setting  $r = r_1$  and recalling that  $p_0(r_1) = 0$  and  $y_1 = y(x, r_1)$  yields

$$L\left(y_1 \ln x + x^{r_1} \sum_{n=1}^{\infty} a'_n(r_1)x^n\right) = p'_0(r_1)x^{r_1}. \tag{7.7.9}$$

Since  $r_1$  and  $r_2$  are the roots of the indicial equation, the indicial polynomial can be written as

$$p_0(r) = \alpha_0(r - r_1)(r - r_2) = \alpha_0[r^2 - (r_1 + r_2)r + r_1r_2].$$

Differentiating this yields

$$p'_0(r) = \alpha_0(2r - r_1 - r_2).$$

Therefore  $p'_0(r_1) = \alpha_0(r_1 - r_2) = k\alpha_0$ , so (7.7.9) implies (7.7.8).

Before proving (7.7.7), we first note  $a_n(r_2)$  is well defined by (7.7.3) for  $1 \leq n \leq k - 1$ , since  $p_0(n + r_2) \neq 0$  for these values of  $n$ . However, we can't define  $a_n(r_2)$  for  $n \geq k$  with (7.7.3), since  $p_0(k + r_2) = p_0(r_1) = 0$ . For convenience, we define  $a_n(r_2) = 0$  for  $n \geq k$ . Then, from Theorem 7.5.1,

$$L\left(x^{r_2} \sum_{n=0}^{k-1} a_n(r_2)x^n\right) = L\left(x^{r_2} \sum_{n=0}^{\infty} a_n(r_2)x^n\right) = x^{r_2} \sum_{n=0}^{\infty} b_n x^n, \tag{7.7.10}$$

where  $b_0 = p_0(r_2) = 0$  and

$$b_n = p_0(n + r_2)a_n(r_2) + p_1(n + r_2 - 1)a_{n-1}(r_2), \quad n \geq 1.$$

If  $1 \leq n \leq k - 1$ , then (7.7.3) implies that  $b_n = 0$ . If  $n \geq k + 1$ , then  $b_n = 0$  because  $a_{n-1}(r_2) = a_n(r_2) = 0$ . Therefore (7.7.10) reduces to

$$L\left(x^{r_2} \sum_{n=0}^{k-1} a_n(r_2)x^n\right) = [p_0(k + r_2)a_k(r_2) + p_1(k + r_2 - 1)a_{k-1}(r_2)]x^{k+r_2}.$$

Since  $a_k(r_2) = 0$  and  $k + r_2 = r_1$ , this implies (7.7.7).

We leave the proof that  $\{y_1, y_2\}$  is a fundamental set as an exercise (Exercise 41).

**Example 7.7.1** Find a fundamental set of Frobenius solutions of

$$2x^2(2 + x)y'' - x(4 - 7x)y' - (5 - 3x)y = 0.$$

Give explicit formulas for the coefficients in the solutions.

**Solution** For the given equation, the polynomials defined in Theorem 7.7.1 are

$$\begin{aligned} p_0(r) &= 4r(r - 1) - 4r - 5 = (2r + 1)(2r - 5), \\ p_1(r) &= 2r(r - 1) + 7r + 3 = (r + 1)(2r + 3). \end{aligned}$$

The roots of the indicial equation are  $r_1 = 5/2$  and  $r_2 = -1/2$ , so  $k = r_1 - r_2 = 3$ . Therefore Theorem 7.7.1 implies that

$$y_1 = x^{5/2} \sum_{n=0}^{\infty} a_n(5/2)x^n \tag{7.7.11}$$

and

$$y_2 = x^{-1/2} \sum_{n=0}^2 a_n(-1/2) + C \left( y_1 \ln x + x^{5/2} \sum_{n=1}^{\infty} a'_n(5/2)x^n \right) \tag{7.7.12}$$

(with  $C$  as in (7.7.4)) form a fundamental set of solutions of  $Ly = 0$ . The recurrence formula (7.7.2) is

$$\begin{aligned} a_0(r) &= 1, \\ a_n(r) &= -\frac{p_1(n+r-1)}{p_0(n+r)}a_{n-1}(r) \\ &= -\frac{(n+r)(2n+2r+1)}{(2n+2r+1)(2n+2r-5)}a_{n-1}(r), \\ &= -\frac{n+r}{2n+2r-5}a_{n-1}(r), \quad n \geq 1, \end{aligned} \quad (7.7.13)$$

which implies that

$$a_n(r) = (-1)^n \prod_{j=1}^n \frac{j+r}{2j+2r-5}, \quad n \geq 0. \quad (7.7.14)$$

Therefore

$$a_n(5/2) = \frac{(-1)^n \prod_{j=1}^n (2j+5)}{4^n n!}. \quad (7.7.15)$$

Substituting this into (7.7.11) yields

$$y_1 = x^{5/2} \sum_{n=0}^{\infty} \frac{(-1)^n \prod_{j=1}^n (2j+5)}{4^n n!} x^n.$$

To compute the coefficients  $a_0(-1/2)$ ,  $a_1(-1/2)$  and  $a_2(-1/2)$  in  $y_2$ , we set  $r = -1/2$  in (7.7.13) and apply the resulting recurrence formula for  $n = 1, 2$ ; thus,

$$\begin{aligned} a_0(-1/2) &= 1, \\ a_n(-1/2) &= -\frac{2n-1}{4(n-3)}a_{n-1}(-1/2), \quad n = 1, 2. \end{aligned}$$

The last formula yields

$$a_1(-1/2) = 1/8 \quad \text{and} \quad a_2(-1/2) = 3/32.$$

Substituting  $r_1 = 5/2$ ,  $r_2 = -1/2$ ,  $k = 3$ , and  $\alpha_0 = 4$  into (7.7.4) yields  $C = -15/128$ . Therefore, from (7.7.12),

$$y_2 = x^{-1/2} \left( 1 + \frac{1}{8}x + \frac{3}{32}x^2 \right) - \frac{15}{128} \left( y_1 \ln x + x^{5/2} \sum_{n=1}^{\infty} a'_n(5/2)x^n \right). \quad (7.7.16)$$

We use logarithmic differentiation to obtain  $a'_n(r)$ . From (7.7.14),

$$|a_n(r)| = \prod_{j=1}^n \frac{|j+r|}{|2j+2r-5|}, \quad n \geq 1.$$

Therefore

$$\ln |a_n(r)| = \sum_{j=1}^n (\ln |j+r| - \ln |2j+2r-5|).$$

Differentiating with respect to  $r$  yields

$$\frac{a'_n(r)}{a_n(r)} = \sum_{j=1}^n \left( \frac{1}{j+r} - \frac{2}{2j+2r-5} \right).$$

Therefore

$$a'_n(r) = a_n(r) \sum_{j=1}^n \left( \frac{1}{j+r} - \frac{2}{2j+2r-5} \right).$$

Setting  $r = 5/2$  here and recalling (7.7.15) yields

$$a'_n(5/2) = \frac{(-1)^n \prod_{j=1}^n (2j+5)}{4^n n!} \sum_{j=1}^n \left( \frac{1}{j+5/2} - \frac{1}{j} \right). \tag{7.7.17}$$

Since

$$\frac{1}{j+5/2} - \frac{1}{j} = -\frac{5}{j(2j+5)},$$

we can rewrite (7.7.17) as

$$a'_n(5/2) = -5 \frac{(-1)^n \prod_{j=1}^n (2j+5)}{4^n n!} \left( \sum_{j=1}^n \frac{1}{j(2j+5)} \right).$$

Substituting this into (7.7.16) yields

$$\begin{aligned} y_2 &= x^{-1/2} \left( 1 + \frac{1}{8}x + \frac{3}{32}x^2 \right) - \frac{15}{128}y_1 \ln x \\ &+ \frac{75}{128}x^{5/2} \sum_{n=1}^{\infty} \frac{(-1)^n \prod_{j=1}^n (2j+5)}{4^n n!} \left( \sum_{j=1}^n \frac{1}{j(2j+5)} \right) x^n. \blacksquare \end{aligned}$$

If  $C = 0$  in (7.7.4), there's no need to compute

$$y_1 \ln x + x^{r_1} \sum_{n=1}^{\infty} a'_n(r_1)x^n$$

in the formula (7.7.5) for  $y_2$ . Therefore it's best to compute  $C$  before computing  $\{a'_n(r_1)\}_{n=1}^{\infty}$ . This is illustrated in the next example. (See also Exercises 44 and 45.)

**Example 7.7.2** Find a fundamental set of Frobenius solutions of

$$x^2(1-2x)y'' + x(8-9x)y' + (6-3x)y = 0.$$

Give explicit formulas for the coefficients in the solutions.

**Solution** For the given equation, the polynomials defined in Theorem 7.7.1 are

$$\begin{aligned} p_0(r) &= r(r-1) + 8r + 6 = (r+1)(r+6) \\ p_1(r) &= -2r(r-1) - 9r - 3 = -(r+3)(2r+1). \end{aligned}$$

The roots of the indicial equation are  $r_1 = -1$  and  $r_2 = -6$ , so  $k = r_1 - r_2 = 5$ . Therefore Theorem 7.7.1 implies that

$$y_1 = x^{-1} \sum_{n=0}^{\infty} a_n(-1)x^n \tag{7.7.18}$$

and

$$y_2 = x^{-6} \sum_{n=0}^4 a_n(-6) + C \left( y_1 \ln x + x^{-1} \sum_{n=1}^{\infty} a'_n(-1)x^n \right) \quad (7.7.19)$$

(with  $C$  as in (7.7.4)) form a fundamental set of solutions of  $Ly = 0$ . The recurrence formula (7.7.2) is

$$\begin{aligned} a_0(r) &= 1, \\ a_n(r) &= -\frac{p_1(n+r-1)}{p_0(n+r)} a_{n-1}(r) \\ &= \frac{(n+r+2)(2n+2r-1)}{(n+r+1)(n+r+6)} a_{n-1}(r), \quad n \geq 1, \end{aligned} \quad (7.7.20)$$

which implies that

$$\begin{aligned} a_n(r) &= \prod_{j=1}^n \frac{(j+r+2)(2j+2r-1)}{(j+r+1)(j+r+6)} \\ &= \left( \prod_{j=1}^n \frac{j+r+2}{j+r+1} \right) \left( \prod_{j=1}^n \frac{2j+2r-1}{j+r+6} \right). \end{aligned} \quad (7.7.21)$$

Since

$$\prod_{j=1}^n \frac{j+r+2}{j+r+1} = \frac{(r+3)(r+4) \cdots (n+r+2)}{(r+2)(r+3) \cdots (n+r+1)} = \frac{n+r+2}{r+2}$$

because of cancellations, (7.7.21) simplifies to

$$a_n(r) = \frac{n+r+2}{r+2} \prod_{j=1}^n \frac{2j+2r-1}{j+r+6}.$$

Therefore

$$a_n(-1) = (n+1) \prod_{j=1}^n \frac{2j-3}{j+5}.$$

Substituting this into (7.7.18) yields

$$y_1 = x^{-1} \sum_{n=0}^{\infty} (n+1) \left( \prod_{j=1}^n \frac{2j-3}{j+5} \right) x^n.$$

To compute the coefficients  $a_0(-6), \dots, a_4(-6)$  in  $y_2$ , we set  $r = -6$  in (7.7.20) and apply the resulting recurrence formula for  $n = 1, 2, 3, 4$ ; thus,

$$\begin{aligned} a_0(-6) &= 1, \\ a_n(-6) &= \frac{(n-4)(2n-13)}{n(n-5)} a_{n-1}(-6), \quad n = 1, 2, 3, 4. \end{aligned}$$

The last formula yields

$$a_1(-6) = -\frac{33}{4}, \quad a_2(-6) = \frac{99}{4}, \quad a_3(-6) = -\frac{231}{8}, \quad a_4(-6) = 0.$$

Since  $a_4(-6) = 0$ , (7.7.4) implies that the constant  $C$  in (7.7.19) is zero. Therefore (7.7.19) reduces to

$$y_2 = x^{-6} \left( 1 - \frac{33}{4}x + \frac{99}{4}x^2 - \frac{231}{8}x^3 \right). \quad \blacksquare$$

We now consider equations of the form

$$x^2(\alpha_0 + \alpha_2 x^2)y'' + x(\beta_0 + \beta_2 x^2)y' + (\gamma_0 + \gamma_2 x^2)y = 0,$$

where the roots of the indicial equation are real and differ by an even integer. The case where the roots are real and differ by an odd integer can be handled by the method discussed in 56.

The proof of the next theorem is similar to the proof of Theorem 7.7.1 (Exercise 43).

**Theorem 7.7.2** *Let*

$$Ly = x^2(\alpha_0 + \alpha_2 x^2)y'' + x(\beta_0 + \beta_2 x^2)y' + (\gamma_0 + \gamma_2 x^2)y,$$

where  $\alpha_0 \neq 0$ , and define

$$p_0(r) = \alpha_0 r(r-1) + \beta_0 r + \gamma_0,$$

$$p_2(r) = \alpha_2 r(r-1) + \beta_2 r + \gamma_2.$$

Suppose  $r$  is a real number such that  $p_0(2m+r)$  is nonzero for all positive integers  $m$ , and define

$$\begin{aligned} a_0(r) &= 1, \\ a_{2m}(r) &= -\frac{p_2(2m+r-2)}{p_0(2m+r)} a_{2m-2}(r), \quad m \geq 1. \end{aligned} \quad (7.7.22)$$

Let  $r_1$  and  $r_2$  be the roots of the indicial equation  $p_0(r) = 0$ , and suppose  $r_1 = r_2 + 2k$ , where  $k$  is a positive integer. Then

$$y_1 = x^{r_1} \sum_{m=0}^{\infty} a_{2m}(r_1) x^{2m}$$

is a Frobenius solution of  $Ly = 0$ . Moreover, if we define

$$\begin{aligned} a_0(r_2) &= 1, \\ a_{2m}(r_2) &= -\frac{p_2(2m+r_2-2)}{p_0(2m+r_2)} a_{2m-2}(r_2), \quad 1 \leq m \leq k-1 \end{aligned}$$

and

$$C = -\frac{p_2(r_1-2)}{2k\alpha_0} a_{2k-2}(r_2), \quad (7.7.23)$$

then

$$y_2 = x^{r_2} \sum_{m=0}^{k-1} a_{2m}(r_2) x^{2m} + C \left( y_1 \ln x + x^{r_1} \sum_{m=1}^{\infty} a'_{2m}(r_1) x^{2m} \right) \quad (7.7.24)$$

is also a solution of  $Ly = 0$ , and  $\{y_1, y_2\}$  is a fundamental set of solutions.

**Example 7.7.3** Find a fundamental set of Frobenius solutions of

$$x^2(1+x^2)y'' + x(3+10x^2)y' - (15-14x^2)y = 0.$$

Give explicit formulas for the coefficients in the solutions.

**Solution** For the given equation, the polynomials defined in Theorem 7.7.2 are

$$\begin{aligned} p_0(r) &= r(r-1) + 3r - 15 = (r-3)(r+5) \\ p_2(r) &= r(r-1) + 10r + 14 = (r+2)(r+7). \end{aligned}$$

The roots of the indicial equation are  $r_1 = 3$  and  $r_2 = -5$ , so  $k = (r_1 - r_2)/2 = 4$ . Therefore Theorem 7.7.2 implies that

$$y_1 = x^3 \sum_{m=0}^{\infty} a_{2m}(3)x^{2m} \quad (7.7.25)$$

and

$$y_2 = x^{-5} \sum_{m=0}^3 a_{2m}(-5)x^{2m} + C \left( y_1 \ln x + x^3 \sum_{m=1}^{\infty} a'_{2m}(3)x^{2m} \right)$$

(with  $C$  as in (7.7.23)) form a fundamental set of solutions of  $Ly = 0$ . The recurrence formula (7.7.22) is

$$\begin{aligned} a_0(r) &= 1, \\ a_{2m}(r) &= -\frac{p_2(2m+r-2)}{p_0(2m+r)} a_{2m-2}(r) \\ &= -\frac{(2m+r)(2m+r+5)}{(2m+r-3)(2m+r+5)} a_{2m-2}(r) \\ &= -\frac{2m+r}{2m+r-3} a_{2m-2}(r), \quad m \geq 1, \end{aligned} \quad (7.7.26)$$

which implies that

$$a_{2m}(r) = (-1)^m \prod_{j=1}^m \frac{2j+r}{2j+r-3}, \quad m \geq 0. \quad (7.7.27)$$

Therefore

$$a_{2m}(3) = \frac{(-1)^m \prod_{j=1}^m (2j+3)}{2^m m!}. \quad (7.7.28)$$

Substituting this into (7.7.25) yields

$$y_1 = x^3 \sum_{m=0}^{\infty} \frac{(-1)^m \prod_{j=1}^m (2j+3)}{2^m m!} x^{2m}.$$

To compute the coefficients  $a_2(-5)$ ,  $a_4(-5)$ , and  $a_6(-5)$  in  $y_2$ , we set  $r = -5$  in (7.7.26) and apply the resulting recurrence formula for  $m = 1, 2, 3$ ; thus,

$$a_{2m}(-5) = -\frac{2m-5}{2(m-4)} a_{2m-2}(-5), \quad m = 1, 2, 3.$$

This yields

$$a_2(-5) = -\frac{1}{2}, \quad a_4(-5) = \frac{1}{8}, \quad a_6(-5) = \frac{1}{16}.$$

Substituting  $r_1 = 3$ ,  $r_2 = -5$ ,  $k = 4$ , and  $\alpha_0 = 1$  into (7.7.23) yields  $C = -3/16$ . Therefore, from (7.7.24),

$$y_2 = x^{-5} \left( 1 - \frac{1}{2}x^2 + \frac{1}{8}x^4 + \frac{1}{16}x^6 \right) - \frac{3}{16} \left( y_1 \ln x + x^3 \sum_{m=1}^{\infty} a'_{2m}(3)x^{2m} \right). \quad (7.7.29)$$



To obtain  $a'_{2m}(r)$  we use logarithmic differentiation. From (7.7.27),

$$|a_{2m}(r)| = \prod_{j=1}^m \frac{|2j+r|}{|2j+r-3|}, \quad m \geq 1.$$

Therefore

$$\ln |a_{2m}(r)| = \sum_{j=1}^m (\ln |2j+r| - \ln |2j+r-3|).$$

Differentiating with respect to  $r$  yields

$$\frac{a'_{2m}(r)}{a_{2m}(r)} = \sum_{j=1}^m \left( \frac{1}{2j+r} - \frac{1}{2j+r-3} \right).$$

Therefore

$$a'_{2m}(r) = a_{2m}(r) \sum_{j=1}^m \left( \frac{1}{2j+r} - \frac{1}{2j+r-3} \right).$$

Setting  $r = 3$  here and recalling (7.7.28) yields

$$a'_{2m}(3) = \frac{(-1)^m \prod_{j=1}^m (2j+3)}{2^m m!} \sum_{j=1}^m \left( \frac{1}{2j+3} - \frac{1}{2j} \right). \quad (7.7.30)$$

Since

$$\frac{1}{2j+3} - \frac{1}{2j} = -\frac{3}{2j(2j+3)},$$

we can rewrite (7.7.30) as

$$a'_{2m}(3) = -\frac{3}{2} \frac{(-1)^m \prod_{j=1}^m (2j+3)}{2^m m!} \left( \sum_{j=1}^m \frac{1}{j(2j+3)} \right).$$

Substituting this into (7.7.29) yields

$$\begin{aligned} y_2 &= x^{-5} \left( 1 - \frac{1}{2}x^2 + \frac{1}{8}x^4 + \frac{1}{16}x^6 \right) - \frac{3}{16}y_1 \ln x \\ &\quad + \frac{9}{32}x^3 \sum_{m=1}^{\infty} \frac{(-1)^m \prod_{j=1}^m (2j+3)}{2^m m!} \left( \sum_{j=1}^m \frac{1}{j(2j+3)} \right) x^{2m}. \end{aligned}$$

**Example 7.7.4** Find a fundamental set of Frobenius solutions of

$$x^2(1-2x^2)y'' + x(7-13x^2)y' - 14x^2y = 0.$$

Give explicit formulas for the coefficients in the solutions.

**Solution** For the given equation, the polynomials defined in Theorem 7.7.2 are

$$\begin{aligned} p_0(r) &= r(r-1) + 7r &= r(r+6), \\ p_2(r) &= -2r(r-1) - 13r - 14 &= -(r+2)(2r+7). \end{aligned}$$

The roots of the indicial equation are  $r_1 = 0$  and  $r_2 = -6$ , so  $k = (r_1 - r_2)/2 = 3$ . Therefore Theorem 7.7.2 implies that

$$y_1 = \sum_{m=0}^{\infty} a_{2m}(0)x^{2m}, \quad (7.7.31)$$

and

$$y_2 = x^{-6} \sum_{m=0}^2 a_{2m}(-6)x^{2m} + C \left( y_1 \ln x + \sum_{m=1}^{\infty} a'_{2m}(0)x^{2m} \right) \quad (7.7.32)$$

(with  $C$  as in (7.7.23)) form a fundamental set of solutions of  $Ly = 0$ . The recurrence formulas (7.7.22) are

$$\begin{aligned} a_0(r) &= 1, \\ a_{2m}(r) &= -\frac{p_2(2m+r-2)}{p_0(2m+r)} a_{2m-2}(r) \\ &= \frac{(2m+r)(4m+2r+3)}{(2m+r)(2m+r+6)} a_{2m-2}(r) \\ &= \frac{4m+2r+3}{2m+r+6} a_{2m-2}(r), \quad m \geq 1, \end{aligned} \quad (7.7.33)$$

which implies that

$$a_{2m}(r) = \prod_{j=1}^m \frac{4j+2r+3}{2j+r+6}.$$

Setting  $r = 0$  yields

$$a_{2m}(0) = 6 \frac{\prod_{j=1}^m (4j+3)}{2^m(m+3)!}.$$

Substituting this into (7.7.31) yields

$$y_1 = 6 \sum_{m=0}^{\infty} \frac{\prod_{j=1}^m (4j+3)}{2^m(m+3)!} x^{2m}.$$

To compute the coefficients  $a_0(-6)$ ,  $a_2(-6)$ , and  $a_4(-6)$  in  $y_2$ , we set  $r = -6$  in (7.7.33) and apply the resulting recurrence formula for  $m = 1, 2$ ; thus,

$$\begin{aligned} a_0(-6) &= 1, \\ a_{2m}(-6) &= \frac{4m-9}{2m} a_{2m-2}(-6), \quad m = 1, 2. \end{aligned}$$

The last formula yields

$$a_2(-6) = -\frac{5}{2} \quad \text{and} \quad a_4(-6) = \frac{5}{8}.$$

Since  $p_2(-2) = 0$ , the constant  $C$  in (7.7.23) is zero. Therefore (7.7.32) reduces to

$$y_2 = x^{-6} \left( 1 - \frac{5}{2}x^2 + \frac{5}{8}x^4 \right).$$

## 7.7 Exercises

In Exercises 1–40 find a fundamental set of Frobenius solutions. Give explicit formulas for the coefficients.

1.  $x^2y'' - 3xy' + (3 + 4x)y = 0$
2.  $xy'' + y = 0$
3.  $4x^2(1 + x)y'' + 4x(1 + 2x)y' - (1 + 3x)y = 0$
4.  $xy'' + xy' + y = 0$
5.  $2x^2(2 + 3x)y'' + x(4 + 21x)y' - (1 - 9x)y = 0$
6.  $x^2y'' + x(2 + x)y' - (2 - 3x)y = 0$
7.  $4x^2y'' + 4xy' - (9 - x)y = 0$
8.  $x^2y'' + 10xy' + (14 + x)y = 0$
9.  $4x^2(1 + x)y'' + 4x(3 + 8x)y' - (5 - 49x)y = 0$
10.  $x^2(1 + x)y'' - x(3 + 10x)y' + 30xy = 0$
11.  $x^2y'' + x(1 + x)y' - 3(3 + x)y = 0$
12.  $x^2y'' + x(1 - 2x)y' - (4 + x)y = 0$
13.  $x(1 + x)y'' - 4y' - 2y = 0$
14.  $x^2(1 + 2x)y'' + x(9 + 13x)y' + (7 + 5x)y = 0$
15.  $4x^2y'' - 2x(4 - x)y' - (7 + 5x)y = 0$
16.  $3x^2(3 + x)y'' - x(15 + x)y' - 20y = 0$
17.  $x^2(1 + x)y'' + x(1 - 10x)y' - (9 - 10x)y = 0$
18.  $x^2(1 + x)y'' + 3x^2y' - (6 - x)y = 0$
19.  $x^2(1 + 2x)y'' - 2x(3 + 14x)y' + (6 + 100x)y = 0$
20.  $x^2(1 + x)y'' - x(6 + 11x)y' + (6 + 32x)y = 0$
21.  $4x^2(1 + x)y'' + 4x(1 + 4x)y' - (49 + 27x)y = 0$
22.  $x^2(1 + 2x)y'' - x(9 + 8x)y' - 12xy = 0$
23.  $x^2(1 + x^2)y'' - x(7 - 2x^2)y' + 12y = 0$
24.  $x^2y'' - x(7 - x^2)y' + 12y = 0$
25.  $xy'' - 5y' + xy = 0$
26.  $x^2y'' + x(1 + 2x^2)y' - (1 - 10x^2)y = 0$
27.  $x^2y'' - xy' - (3 - x^2)y = 0$
28.  $4x^2y'' + 2x(8 + x^2)y' + (5 + 3x^2)y = 0$
29.  $x^2y'' + x(1 + x^2)y' - (1 - 3x^2)y = 0$
30.  $x^2y'' + x(1 - 2x^2)y' - 4(1 + 2x^2)y = 0$
31.  $4x^2y'' + 8xy' - (35 - x^2)y = 0$
32.  $9x^2y'' - 3x(11 + 2x^2)y' + (13 + 10x^2)y = 0$
33.  $x^2y'' + x(1 - 2x^2)y' - 4(1 - x^2)y = 0$
34.  $x^2y'' + x(1 - 3x^2)y' - 4(1 - 3x^2)y = 0$
35.  $x^2(1 + x^2)y'' + x(5 + 11x^2)y' + 24x^2y = 0$
36.  $4x^2(1 + x^2)y'' + 8xy' - (35 - x^2)y = 0$
37.  $x^2(1 + x^2)y'' - x(5 - x^2)y' - (7 + 25x^2)y = 0$

38.  $x^2(1+x^2)y'' + x(5+2x^2)y' - 21y = 0$   
 39.  $x^2(1+2x^2)y'' - x(3+x^2)y' - 2x^2y = 0$   
 40.  $4x^2(1+x^2)y'' + 4x(2+x^2)y' - (15+x^2)y = 0$   
 41. (a) Under the assumptions of Theorem 7.7.1, show that

$$y_1 = x^{r_1} \sum_{n=0}^{\infty} a_n(r_1)x^n$$

and

$$y_2 = x^{r_2} \sum_{n=0}^{k-1} a_n(r_2)x^n + C \left( y_1 \ln x + x^{r_1} \sum_{n=1}^{\infty} a'_n(r_1)x^n \right)$$

are linearly independent. HINT: Show that if  $c_1$  and  $c_2$  are constants such that  $c_1y_1 + c_2y_2 \equiv 0$  on an interval  $(0, \rho)$ , then

$$x^{-r_2}(c_1y_1(x) + c_2y_2(x)) = 0, \quad 0 < x < \rho.$$

Then let  $x \rightarrow 0+$  to conclude that  $c_2=0$ .

- (b) Use the result of (a) to complete the proof of Theorem 7.7.1.  
 42. Find a fundamental set of Frobenius solutions of Bessel's equation

$$x^2y'' + xy' + (x^2 - \nu^2)y = 0$$

in the case where  $\nu$  is a positive integer.

43. Prove Theorem 7.7.2.  
 44. Under the assumptions of Theorem 7.7.1, show that  $C = 0$  if and only if  $p_1(r_2 + ) = 0$  for some integer in  $\{0, 1, \dots, k-1\}$ .  
 45. Under the assumptions of Theorem 7.7.2, show that  $C = 0$  if and only if  $p_2(r_2 + 2) = 0$  for some integer  $\ell$  in  $\{0, 1, \dots, k-1\}$ .  
 46. Let

$$Ly = \alpha_0x^2y'' + \beta_0xy' + (\gamma_0 + \gamma_1x)y$$

and define

$$p_0(r) = \alpha_0r(r-1) + \beta_0r + \gamma_0.$$

Show that if

$$p_0(r) = \alpha_0(r-r_1)(r-r_2)$$

where  $r_1 - r_2 = k$ , a positive integer, then  $Ly = 0$  has the solutions

$$y_1 = x^{r_1} \sum_{n=0}^{\infty} \frac{(-1)^n}{n! \prod_{j=1}^n (j+k)} \left( \frac{\gamma_1}{\alpha_0} \right)^n x^n$$

and

$$y_2 = x^{r_2} \sum_{n=0}^{k-1} \frac{(-1)^n}{n! \prod_{j=1}^n (j-k)} \left( \frac{\gamma_1}{\alpha_0} \right)^n x^n - \frac{1}{k!(k-1)!} \left( \frac{\gamma_1}{\alpha_0} \right)^k \left( y_1 \ln x - x^{r_1} \sum_{n=1}^{\infty} \frac{(-1)^n}{n! \prod_{j=1}^n (j+k)} \left( \frac{\gamma_1}{\alpha_0} \right)^n \left( \sum_{j=1}^n \frac{2j+k}{j(j+k)} \right) x^n \right).$$

47. Let

$$Ly = \alpha_0 x^2 y'' + \beta_0 x y' + (\gamma_0 + \gamma_2 x^2) y$$

and define

$$p_0(r) = \alpha_0 r(r - 1) + \beta_0 r + \gamma_0.$$

Show that if

$$p_0(r) = \alpha_0(r - r_1)(r - r_2)$$

where  $r_1 - r_2 = 2k$ , an even positive integer, then  $Ly = 0$  has the solutions

$$y_1 = x^{r_1} \sum_{m=0}^{\infty} \frac{(-1)^m}{4^m m! \prod_{j=1}^m (j+k)} \left(\frac{\gamma_2}{\alpha_0}\right)^m x^{2m}$$

and

$$y_2 = x^{r_2} \sum_{m=0}^{k-1} \frac{(-1)^m}{4^m m! \prod_{j=1}^m (j-k)} \left(\frac{\gamma_2}{\alpha_0}\right)^m x^{2m} - \frac{2}{4^k k!(k-1)!} \left(\frac{\gamma_2}{\alpha_0}\right)^k \left( y_1 \ln x - \frac{x^{r_1}}{2} \sum_{m=1}^{\infty} \frac{(-1)^m}{4^m m! \prod_{j=1}^m (j+k)} \left(\frac{\gamma_2}{\alpha_0}\right)^m \left( \sum_{j=1}^m \frac{2j+k}{j(j+k)} \right) x^{2m} \right).$$

48. Let  $L$  be as in Exercises 7.5.57 and 7.5.58, and suppose the indicial polynomial of  $Ly = 0$  is

$$p_0(r) = \alpha_0(r - r_1)(r - r_2),$$

with  $k = r_1 - r_2$ , where  $k$  is a positive integer. Define  $a_0(r) = 1$  for all  $r$ . If  $r$  is a real number such that  $p_0(n+r)$  is nonzero for all positive integers  $n$ , define

$$a_n(r) = -\frac{1}{p_0(n+r)} \sum_{j=1}^n p_j(n+r-j) a_{n-j}(r), \quad n \geq 1,$$

and let

$$y_1 = x^{r_1} \sum_{n=0}^{\infty} a_n(r_1) x^n.$$

Define

$$a_n(r_2) = -\frac{1}{p_0(n+r_2)} \sum_{j=1}^n p_j(n+r_2-j) a_{n-j}(r_2) \text{ if } n \geq 1 \text{ and } n \neq k,$$

and let  $a_k(r_2)$  be arbitrary.

(a) Conclude from Exercise 7.6..66 that

$$L \left( y_1 \ln x + x^{r_1} \sum_{n=1}^{\infty} a'_n(r_1) x^n \right) = k \alpha_0 x^{r_1}.$$

(b) Conclude from Exercise 7.5..57 that

$$L \left( x^{r_2} \sum_{n=0}^{\infty} a_n(r_2) x^n \right) = A x^{r_1},$$

where

$$A = \sum_{j=1}^k p_j(r_1 - j)a_{k-j}(r_2).$$

(c) Show that  $y_1$  and

$$y_2 = x^{r_2} \sum_{n=0}^{\infty} a_n(r_2)x^n - \frac{A}{k\alpha_0} \left( y_1 \ln x + x^{r_1} \sum_{n=1}^{\infty} a'_n(r_1)x^n \right)$$

form a fundamental set of Frobenius solutions of  $Ly = 0$ .

(d) Show that choosing the arbitrary quantity  $a_k(r_2)$  to be nonzero merely adds a multiple of  $y_1$  to  $y_2$ . Conclude that we may as well take  $a_k(r_2) = 0$ .

# CHAPTER 8

## Laplace Transforms

IN THIS CHAPTER we study the method of *Laplace transforms*, which illustrates one of the basic problem solving techniques in mathematics: transform a difficult problem into an easier one, solve the latter, and then use its solution to obtain a solution of the original problem. The method discussed here transforms an initial value problem for a constant coefficient equation into an algebraic equation whose solution can then be used to solve the initial value problem. In some cases this method is merely an alternative procedure for solving problems that can be solved equally well by methods that we considered previously; however, in other cases the method of Laplace transforms is more efficient than the methods previously discussed. This is especially true in physical problems dealing with discontinuous forcing functions.

SECTION 8.1 defines the Laplace transform and develops its properties.

SECTION 8.2 deals with the problem of finding a function that has a given Laplace transform.

SECTION 8.3 applies the Laplace transform to solve initial value problems for constant coefficient second order differential equations on  $(0, \infty)$ .

SECTION 8.4 introduces the unit step function.

SECTION 8.5 uses the unit step function to solve constant coefficient equations with piecewise continuous forcing functions.

SECTION 8.6 deals with the convolution theorem, an important theoretical property of the Laplace transform.

SECTION 8.7 introduces the idea of impulsive force, and treats constant coefficient equations with impulsive forcing functions.

SECTION 8.8 is a brief table of Laplace transforms.

## 8.1 INTRODUCTION TO THE LAPLACE TRANSFORM

### Definition of the Laplace Transform

To define the Laplace transform, we first recall the definition of an improper integral. If  $g$  is integrable over the interval  $[a, T]$  for every  $T > a$ , then the *improper integral of  $g$  over  $[a, \infty)$*  is defined as

$$\int_a^\infty g(t) dt = \lim_{T \rightarrow \infty} \int_a^T g(t) dt. \quad (8.1.1)$$

We say that the improper integral *converges* if the limit in (8.1.1) exists; otherwise, we say that the improper integral *diverges* or *does not exist*. Here's the definition of the Laplace transform of a function  $f$ .

**Definition 8.1.1** Let  $f$  be defined for  $t \geq 0$  and let  $s$  be a real number. Then the *Laplace transform of  $f$*  is the function  $F$  defined by

$$F(s) = \int_0^\infty e^{-st} f(t) dt, \quad (8.1.2)$$

for those values of  $s$  for which the improper integral converges.

It is important to keep in mind that the variable of integration in (8.1.2) is  $t$ , while  $s$  is a parameter independent of  $t$ . We use  $t$  as the independent variable for  $f$  because in applications the Laplace transform is usually applied to functions of time.

The Laplace transform can be viewed as an operator  $\mathcal{L}$  that transforms the function  $f = f(t)$  into the function  $F = F(s)$ . Thus, (8.1.2) can be expressed as

$$F = \mathcal{L}(f).$$

The functions  $f$  and  $F$  form a *transform pair*, which we'll sometimes denote by

$$f(t) \leftrightarrow F(s).$$

It can be shown that if  $F(s)$  is defined for  $s = s_0$  then it's defined for all  $s > s_0$  (Exercise 14(b)).

### Computation of Some Simple Laplace Transforms

**Example 8.1.1** Find the Laplace transform of  $f(t) = 1$ .

**Solution** From (8.1.2) with  $f(t) = 1$ ,

$$F(s) = \int_0^\infty e^{-st} dt = \lim_{T \rightarrow \infty} \int_0^T e^{-st} dt.$$

If  $s \neq 0$  then

$$\int_0^T e^{-st} dt = -\frac{1}{s} e^{-st} \Big|_0^T = \frac{1 - e^{-sT}}{s}. \quad (8.1.3)$$

Therefore

$$\lim_{T \rightarrow \infty} \int_0^T e^{-st} dt = \begin{cases} \frac{1}{s}, & s > 0, \\ \infty, & s < 0. \end{cases} \quad (8.1.4)$$



If  $s = 0$  the integrand reduces to the constant 1, and

$$\lim_{T \rightarrow \infty} \int_0^T 1 \, dt = \lim_{T \rightarrow \infty} \int_0^T 1 \, dt = \lim_{T \rightarrow \infty} T = \infty.$$

Therefore  $F(0)$  is undefined, and

$$F(s) = \int_0^{\infty} e^{-st} \, dt = \frac{1}{s}, \quad s > 0.$$

This result can be written in operator notation as

$$\mathcal{L}(1) = \frac{1}{s}, \quad s > 0,$$

or as the transform pair

$$1 \leftrightarrow \frac{1}{s}, \quad s > 0.$$

**REMARK:** It is convenient to combine the steps of integrating from 0 to  $T$  and letting  $T \rightarrow \infty$ . Therefore, instead of writing (8.1.3) and (8.1.4) as separate steps we write

$$\int_0^{\infty} e^{-st} \, dt = -\frac{1}{s} e^{-st} \Big|_0^{\infty} = \begin{cases} \frac{1}{s}, & s > 0, \\ \infty, & s < 0. \end{cases}$$

We'll follow this practice throughout this chapter.

**Example 8.1.2** Find the Laplace transform of  $f(t) = t$ .

**Solution** From (8.1.2) with  $f(t) = t$ ,

$$F(s) = \int_0^{\infty} e^{-st} t \, dt. \quad (8.1.5)$$

If  $s \neq 0$ , integrating by parts yields

$$\begin{aligned} \int_0^{\infty} e^{-st} t \, dt &= -\frac{te^{-st}}{s} \Big|_0^{\infty} + \frac{1}{s} \int_0^{\infty} e^{-st} \, dt = -\left[ \frac{t}{s} + \frac{1}{s^2} \right] e^{-st} \Big|_0^{\infty} \\ &= \begin{cases} \frac{1}{s^2}, & s > 0, \\ \infty, & s < 0. \end{cases} \end{aligned}$$

If  $s = 0$ , the integral in (8.1.5) becomes

$$\int_0^{\infty} t \, dt = \frac{t^2}{2} \Big|_0^{\infty} = \infty.$$

Therefore  $F(0)$  is undefined and

$$F(s) = \frac{1}{s^2}, \quad s > 0.$$

This result can also be written as

$$\mathcal{L}(t) = \frac{1}{s^2}, \quad s > 0,$$

or as the transform pair

$$t \leftrightarrow \frac{1}{s^2}, \quad s > 0.$$

**Example 8.1.3** Find the Laplace transform of  $f(t) = e^{at}$ , where  $a$  is a constant.

**Solution** From (8.1.2) with  $f(t) = e^{at}$ ,

$$F(s) = \int_0^{\infty} e^{-st} e^{at} dt.$$

Combining the exponentials yields

$$F(s) = \int_0^{\infty} e^{-(s-a)t} dt.$$

However, we know from Example 8.1.1 that

$$\int_0^{\infty} e^{-st} dt = \frac{1}{s}, \quad s > 0.$$

Replacing  $s$  by  $s - a$  here shows that

$$F(s) = \frac{1}{s-a}, \quad s > a.$$

This can also be written as

$$\mathcal{L}(e^{at}) = \frac{1}{s-a}, \quad s > a, \quad \text{or} \quad e^{at} \leftrightarrow \frac{1}{s-a}, \quad s > a.$$

**Example 8.1.4** Find the Laplace transforms of  $f(t) = \sin \omega t$  and  $g(t) = \cos \omega t$ , where  $\omega$  is a constant.

**Solution** Define

$$F(s) = \int_0^{\infty} e^{-st} \sin \omega t dt \tag{8.1.6}$$

and

$$G(s) = \int_0^{\infty} e^{-st} \cos \omega t dt. \tag{8.1.7}$$

If  $s > 0$ , integrating (8.1.6) by parts yields

$$F(s) = -\frac{e^{-st}}{s} \sin \omega t \Big|_0^{\infty} + \frac{\omega}{s} \int_0^{\infty} e^{-st} \cos \omega t dt,$$

so

$$F(s) = \frac{\omega}{s} G(s). \tag{8.1.8}$$

If  $s > 0$ , integrating (8.1.7) by parts yields

$$G(s) = -\frac{e^{-st} \cos \omega t}{s} \Big|_0^{\infty} - \frac{\omega}{s} \int_0^{\infty} e^{-st} \sin \omega t dt,$$

so

$$G(s) = \frac{1}{s} - \frac{\omega}{s} F(s).$$

Now substitute from (8.1.8) into this to obtain

$$G(s) = \frac{1}{s} - \frac{\omega^2}{s^2} G(s).$$

Solving this for  $G(s)$  yields

$$G(s) = \frac{s}{s^2 + \omega^2}, \quad s > 0.$$

This and (8.1.8) imply that

$$F(s) = \frac{\omega}{s^2 + \omega^2}, \quad s > 0.$$

### Tables of Laplace transforms

Extensive tables of Laplace transforms have been compiled and are commonly used in applications. The brief table of Laplace transforms in the Appendix will be adequate for our purposes.

**Example 8.1.5** Use the table of Laplace transforms to find  $\mathcal{L}(t^3 e^{4t})$ .

**Solution** The table includes the transform pair

$$t^n e^{at} \leftrightarrow \frac{n!}{(s-a)^{n+1}}.$$

Setting  $n = 3$  and  $a = 4$  here yields

$$\mathcal{L}(t^3 e^{4t}) = \frac{3!}{(s-4)^4} = \frac{6}{(s-4)^4}. \blacksquare$$

We'll sometimes write Laplace transforms of specific functions without explicitly stating how they are obtained. In such cases you should refer to the table of Laplace transforms.

### Linearity of the Laplace Transform

The next theorem presents an important property of the Laplace transform.

**Theorem 8.1.2** [*Linearity Property*] Suppose  $\mathcal{L}(f_i)$  is defined for  $s > s_i$ ,  $1 \leq i \leq n$ . Let  $s_0$  be the largest of the numbers  $s_1, s_2, \dots, s_n$ , and let  $c_1, c_2, \dots, c_n$  be constants. Then

$$\mathcal{L}(c_1 f_1 + c_2 f_2 + \dots + c_n f_n) = c_1 \mathcal{L}(f_1) + c_2 \mathcal{L}(f_2) + \dots + c_n \mathcal{L}(f_n) \text{ for } s > s_0.$$

**Proof** We give the proof for the case where  $n = 2$ . If  $s > s_0$  then

$$\begin{aligned} \mathcal{L}(c_1 f_1 + c_2 f_2) &= \int_0^\infty e^{-st} (c_1 f_1(t) + c_2 f_2(t)) dt \\ &= c_1 \int_0^\infty e^{-st} f_1(t) dt + c_2 \int_0^\infty e^{-st} f_2(t) dt \\ &= c_1 \mathcal{L}(f_1) + c_2 \mathcal{L}(f_2). \end{aligned}$$

**Example 8.1.6** Use Theorem 8.1.2 and the known Laplace transform

$$\mathcal{L}(e^{at}) = \frac{1}{s-a}$$

to find  $\mathcal{L}(\cosh bt)$  ( $b \neq 0$ ).

**Solution** By definition,

$$\cosh bt = \frac{e^{bt} + e^{-bt}}{2}.$$

Therefore

$$\begin{aligned} \mathcal{L}(\cosh bt) &= \mathcal{L}\left(\frac{1}{2}e^{bt} + \frac{1}{2}e^{-bt}\right) \\ &= \frac{1}{2}\mathcal{L}(e^{bt}) + \frac{1}{2}\mathcal{L}(e^{-bt}) \quad (\text{linearity property}) \\ &= \frac{1}{2} \frac{1}{s-b} + \frac{1}{2} \frac{1}{s+b}, \end{aligned} \quad (8.1.9)$$

where the first transform on the right is defined for  $s > b$  and the second for  $s > -b$ ; hence, both are defined for  $s > |b|$ . Simplifying the last expression in (8.1.9) yields

$$\mathcal{L}(\cosh bt) = \frac{s}{s^2 - b^2}, \quad s > |b|.$$

### The First Shifting Theorem

The next theorem enables us to start with known transform pairs and derive others. (For other results of this kind, see Exercises 6 and 13.)

**Theorem 8.1.3** [*First Shifting Theorem*] *If*

$$F(s) = \int_0^{\infty} e^{-st} f(t) dt \quad (8.1.10)$$

*is the Laplace transform of  $f(t)$  for  $s > s_0$ , then  $F(s - a)$  is the Laplace transform of  $e^{at} f(t)$  for  $s > s_0 + a$ .*

PROOF. Replacing  $s$  by  $s - a$  in (8.1.10) yields

$$F(s - a) = \int_0^{\infty} e^{-(s-a)t} f(t) dt \quad (8.1.11)$$

if  $s - a > s_0$ ; that is, if  $s > s_0 + a$ . However, (8.1.11) can be rewritten as

$$F(s - a) = \int_0^{\infty} e^{-st} (e^{at} f(t)) dt,$$

which implies the conclusion.

**Example 8.1.7** Use Theorem 8.1.3 and the known Laplace transforms of 1,  $t$ ,  $\cos \omega t$ , and  $\sin \omega t$  to find

$$\mathcal{L}(e^{at}), \quad \mathcal{L}(te^{at}), \quad \mathcal{L}(e^{\lambda t} \sin \omega t), \quad \text{and} \quad \mathcal{L}(e^{\lambda t} \cos \omega t).$$

**Solution** In the following table the known transform pairs are listed on the left and the required transform pairs listed on the right are obtained by applying Theorem 8.1.3.

$f(t) \leftrightarrow F(s)$	$e^{at}f(t) \leftrightarrow F(s-a)$
$1 \leftrightarrow \frac{1}{s}, \quad s > 0$	$e^{at} \leftrightarrow \frac{1}{(s-a)}, \quad s > a$
$t \leftrightarrow \frac{1}{s^2}, \quad s > 0$	$te^{at} \leftrightarrow \frac{1}{(s-a)^2}, \quad s > a$
$\sin \omega t \leftrightarrow \frac{\omega}{s^2 + \omega^2}, \quad s > 0$	$e^{\lambda t} \sin \omega t \leftrightarrow \frac{\omega}{(s-\lambda)^2 + \omega^2}, \quad s > \lambda$
$\cos \omega t \leftrightarrow \frac{s}{s^2 + \omega^2}, \quad s > 0$	$e^{\lambda t} \cos \omega t \leftrightarrow \frac{s-\lambda}{(s-\lambda)^2 + \omega^2}, \quad s > \lambda$

**Existence of Laplace Transforms**

Not every function has a Laplace transform. For example, it can be shown (Exercise 3) that

$$\int_0^\infty e^{-st} e^{t^2} dt = \infty$$

for every real number  $s$ . Hence, the function  $f(t) = e^{t^2}$  does not have a Laplace transform.

Our next objective is to establish conditions that ensure the existence of the Laplace transform of a function. We first review some relevant definitions from calculus.

Recall that a limit

$$\lim_{t \rightarrow t_0} f(t)$$

exists if and only if the one-sided limits

$$\lim_{t \rightarrow t_0^-} f(t) \quad \text{and} \quad \lim_{t \rightarrow t_0^+} f(t)$$

both exist and are equal; in this case,

$$\lim_{t \rightarrow t_0} f(t) = \lim_{t \rightarrow t_0^-} f(t) = \lim_{t \rightarrow t_0^+} f(t).$$

Recall also that  $f$  is continuous at a point  $t_0$  in an open interval  $(a, b)$  if and only if

$$\lim_{t \rightarrow t_0} f(t) = f(t_0),$$

which is equivalent to

$$\lim_{t \rightarrow t_0^+} f(t) = \lim_{t \rightarrow t_0^-} f(t) = f(t_0). \tag{8.1.12}$$

For simplicity, we define

$$f(t_0+) = \lim_{t \rightarrow t_0^+} f(t) \quad \text{and} \quad f(t_0-) = \lim_{t \rightarrow t_0^-} f(t),$$

so (8.1.12) can be expressed as

$$f(t_0+) = f(t_0-) = f(t_0).$$

If  $f(t_0+)$  and  $f(t_0-)$  have finite but distinct values, we say that  $f$  has a *jump discontinuity* at  $t_0$ , and

$$f(t_0+) - f(t_0-)$$

is called the *jump* in  $f$  at  $t_0$  (Figure 8.1.1).

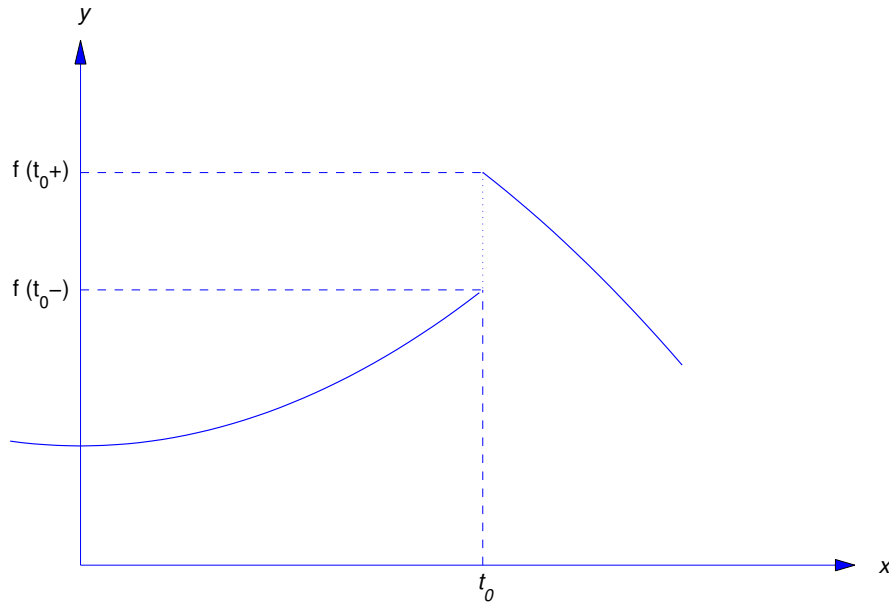

Figure 8.1.1 A jump discontinuity

If  $f(t_0+)$  and  $f(t_0-)$  are finite and equal, but either  $f$  isn't defined at  $t_0$  or it's defined but

$$f(t_0) \neq f(t_0+) = f(t_0-),$$

we say that  $f$  has a *removable discontinuity* at  $t_0$  (Figure 8.1.2). This terminology is appropriate since a function  $f$  with a removable discontinuity at  $t_0$  can be made continuous at  $t_0$  by defining (or redefining)

$$f(t_0) = f(t_0+) = f(t_0-).$$

**REMARK:** We know from calculus that a definite integral isn't affected by changing the values of its integrand at isolated points. Therefore, redefining a function  $f$  to make it continuous at removable discontinuities does not change  $\mathcal{L}(f)$ .

#### Definition 8.1.4

- (i) A function  $f$  is said to be *piecewise continuous* on a finite closed interval  $[0, T]$  if  $f(0+)$  and  $f(T-)$  are finite and  $f$  is continuous on the open interval  $(0, T)$  except possibly at finitely many points, where  $f$  may have jump discontinuities or removable discontinuities.
- (ii) A function  $f$  is said to be *piecewise continuous* on the infinite interval  $[0, \infty)$  if it's piecewise continuous on  $[0, T]$  for every  $T > 0$ .

Figure 8.1.3 shows the graph of a typical piecewise continuous function.

It is shown in calculus that if a function is piecewise continuous on a finite closed interval then it's integrable on that interval. But if  $f$  is piecewise continuous on  $[0, \infty)$ , then so is  $e^{-st}f(t)$ , and therefore

$$\int_0^T e^{-st} f(t) dt$$

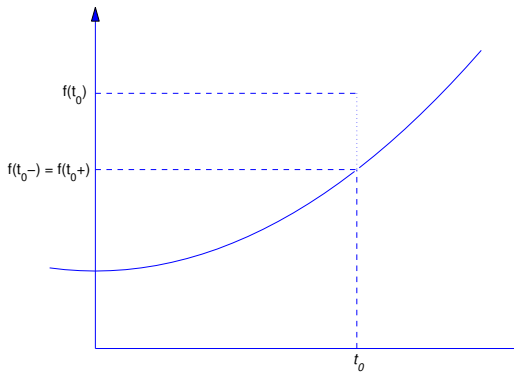

Figure 8.1.2

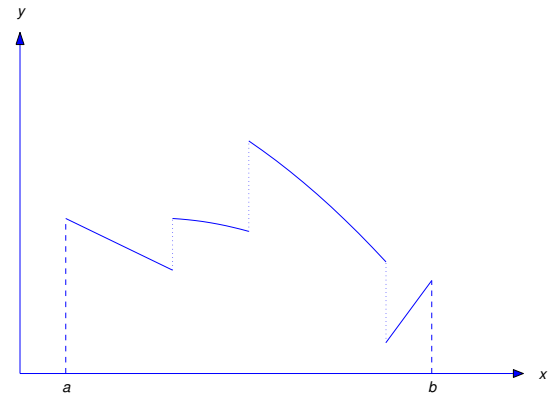

Figure 8.1.3 A piecewise continuous function on  $[a, b]$

exists for every  $T > 0$ . However, piecewise continuity alone does not guarantee that the improper integral

$$\int_0^\infty e^{-st} f(t) dt = \lim_{T \rightarrow \infty} \int_0^T e^{-st} f(t) dt \tag{8.1.13}$$

converges for  $s$  in some interval  $(s_0, \infty)$ . For example, we noted earlier that (8.1.13) diverges for all  $s$  if  $f(t) = e^{t^2}$ . Stated informally, this occurs because  $e^{t^2}$  increases too rapidly as  $t \rightarrow \infty$ . The next definition provides a constraint on the growth of a function that guarantees convergence of its Laplace transform for  $s$  in some interval  $(s_0, \infty)$ .

**Definition 8.1.5** A function  $f$  is said to be of exponential order  $s_0$  if there are constants  $M$  and  $t_0$  such that

$$|f(t)| \leq M e^{s_0 t}, \quad t \geq t_0. \tag{8.1.14}$$

In situations where the specific value of  $s_0$  is irrelevant we say simply that  $f$  is of exponential order.

The next theorem gives useful sufficient conditions for a function  $f$  to have a Laplace transform. The proof is sketched in Exercise 10.

**Theorem 8.1.6** If  $f$  is piecewise continuous on  $[0, \infty)$  and of exponential order  $s_0$ , then  $\mathcal{L}(f)$  is defined for  $s > s_0$ .

**REMARK:** We emphasize that the conditions of Theorem 8.1.6 are sufficient, but *not necessary*, for  $f$  to have a Laplace transform. For example, Exercise 14(c) shows that  $f$  may have a Laplace transform even though  $f$  isn't of exponential order.

**Example 8.1.8** If  $f$  is bounded on some interval  $[t_0, \infty)$ , say

$$|f(t)| \leq M, \quad t \geq t_0,$$

then (8.1.14) holds with  $s_0 = 0$ , so  $f$  is of exponential order zero. Thus, for example,  $\sin \omega t$  and  $\cos \omega t$  are of exponential order zero, and Theorem 8.1.6 implies that  $\mathcal{L}(\sin \omega t)$  and  $\mathcal{L}(\cos \omega t)$  exist for  $s > 0$ . This is consistent with the conclusion of Example 8.1.4.

**Example 8.1.9** It can be shown that if  $\lim_{t \rightarrow \infty} e^{-s_0 t} f(t)$  exists and is finite then  $f$  is of exponential order  $s_0$  (Exercise 9). If  $\alpha$  is any real number and  $s_0 > 0$  then  $f(t) = t^\alpha$  is of exponential order  $s_0$ , since

$$\lim_{t \rightarrow \infty} e^{-s_0 t} t^\alpha = 0,$$

by L'Hôpital's rule. If  $\alpha \geq 0$ ,  $f$  is also continuous on  $[0, \infty)$ . Therefore Exercise 9 and Theorem 8.1.6 imply that  $\mathcal{L}(t^\alpha)$  exists for  $s \geq s_0$ . However, since  $s_0$  is an arbitrary positive number, this really implies that  $\mathcal{L}(t^\alpha)$  exists for all  $s > 0$ . This is consistent with the results of Example 8.1.2 and Exercises 6 and 8.

**Example 8.1.10** Find the Laplace transform of the piecewise continuous function

$$f(t) = \begin{cases} 1, & 0 \leq t < 1, \\ -3e^{-t}, & t \geq 1. \end{cases}$$

**Solution** Since  $f$  is defined by different formulas on  $[0, 1)$  and  $[1, \infty)$ , we write

$$F(s) = \int_0^\infty e^{-st} f(t) dt = \int_0^1 e^{-st}(1) dt + \int_1^\infty e^{-st}(-3e^{-t}) dt.$$

Since

$$\int_0^1 e^{-st} dt = \begin{cases} \frac{1 - e^{-s}}{s}, & s \neq 0, \\ 1, & s = 0, \end{cases}$$

and

$$\int_1^\infty e^{-st}(-3e^{-t}) dt = -3 \int_1^\infty e^{-(s+1)t} dt = -\frac{3e^{-(s+1)}}{s+1}, \quad s > -1,$$

it follows that

$$F(s) = \begin{cases} \frac{1 - e^{-s}}{s} - 3 \frac{e^{-(s+1)}}{s+1}, & s > -1, s \neq 0, \\ 1 - \frac{3}{e}, & s = 0. \end{cases}$$

This is consistent with Theorem 8.1.6, since

$$|f(t)| \leq 3e^{-t}, \quad t \geq 1,$$

and therefore  $f$  is of exponential order  $s_0 = -1$ .

**REMARK:** In Section 8.4 we'll develop a more efficient method for finding Laplace transforms of piecewise continuous functions.

**Example 8.1.11** We stated earlier that

$$\int_0^\infty e^{-st} e^{t^2} dt = \infty$$

for all  $s$ , so Theorem 8.1.6 implies that  $f(t) = e^{t^2}$  is not of exponential order, since

$$\lim_{t \rightarrow \infty} \frac{e^{t^2}}{Me^{s_0 t}} = \lim_{t \rightarrow \infty} \frac{1}{M} e^{t^2 - s_0 t} = \infty,$$

so

$$e^{t^2} > Me^{s_0 t}$$

for sufficiently large values of  $t$ , for any choice of  $M$  and  $s_0$  (Exercise 3).





(c) Show that if  $f$  is of exponential order  $s_0$  and  $g(t) = f(t + \tau)$  where  $\tau > 0$ , then  $g$  is also of exponential order  $s_0$ .

10. Recall the next theorem from calculus.

**THEOREM A.** *Let  $g$  be integrable on  $[0, T]$  for every  $T > 0$ . Suppose there's a function  $w$  defined on some interval  $[\tau, \infty)$  (with  $\tau \geq 0$ ) such that  $|g(t)| \leq w(t)$  for  $t \geq \tau$  and  $\int_{\tau}^{\infty} w(t) dt$  converges. Then  $\int_0^{\infty} g(t) dt$  converges.*

Use Theorem A to show that if  $f$  is piecewise continuous on  $[0, \infty)$  and of exponential order  $s_0$ , then  $f$  has a Laplace transform  $F(s)$  defined for  $s > s_0$ .

11. Prove: If  $f$  is piecewise continuous and of exponential order then  $\lim_{s \rightarrow \infty} F(s) = 0$ .

12. Prove: If  $f$  is continuous on  $[0, \infty)$  and of exponential order  $s_0 > 0$ , then

$$\mathcal{L}\left(\int_0^t f(\tau) d\tau\right) = \frac{1}{s}\mathcal{L}(f), \quad s > s_0.$$

HINT: Use integration by parts to evaluate the transform on the left.

13. Suppose  $f$  is piecewise continuous and of exponential order, and that  $\lim_{t \rightarrow 0^+} f(t)/t$  exists. Show that

$$\mathcal{L}\left(\frac{f(t)}{t}\right) = \int_s^{\infty} F(r) dr.$$

HINT: Use the results of Exercises 6 and 11.

14. Suppose  $f$  is piecewise continuous on  $[0, \infty)$ .

(a) Prove: If the integral  $g(t) = \int_0^t e^{-s_0\tau} f(\tau) d\tau$  satisfies the inequality  $|g(t)| \leq M$  ( $t \geq 0$ ), then  $f$  has a Laplace transform  $F(s)$  defined for  $s > s_0$ . HINT: Use integration by parts to show that

$$\int_0^T e^{-st} f(t) dt = e^{-(s-s_0)T} g(T) + (s-s_0) \int_0^T e^{-(s-s_0)t} g(t) dt.$$

(b) Show that if  $\mathcal{L}(f)$  exists for  $s = s_0$  then it exists for  $s > s_0$ . Show that the function

$$f(t) = te^{t^2} \cos(e^{t^2})$$

has a Laplace transform defined for  $s > 0$ , even though  $f$  isn't of exponential order.

(c) Show that the function

$$f(t) = te^{t^2} \cos(e^{t^2})$$

has a Laplace transform defined for  $s > 0$ , even though  $f$  isn't of exponential order.

15. Use the table of Laplace transforms and the result of Exercise 13 to find the Laplace transforms of the following functions.

$$(a) \frac{\sin \omega t}{t} \quad (\omega > 0) \quad (b) \frac{\cos \omega t - 1}{t} \quad (\omega > 0) \quad (c) \frac{e^{at} - e^{bt}}{t}$$

$$(d) \frac{\cosh t - 1}{t} \quad (e) \frac{\sinh^2 t}{t}$$

16. The *gamma function* is defined by

$$\Gamma(\alpha) = \int_0^{\infty} x^{\alpha-1} e^{-x} dx,$$

which can be shown to converge if  $\alpha > 0$ .

(a) Use integration by parts to show that

$$\Gamma(\alpha + 1) = \alpha\Gamma(\alpha), \quad \alpha > 0.$$

(b) Show that  $\Gamma(n + 1) = n!$  if  $n = 1, 2, 3, \dots$

(c) From (b) and the table of Laplace transforms,

$$\mathcal{L}(t^\alpha) = \frac{\Gamma(\alpha + 1)}{s^{\alpha+1}}, \quad s > 0,$$

if  $\alpha$  is a nonnegative integer. Show that this formula is valid for any  $\alpha > -1$ . HINT: Change the variable of integration in the integral for  $\Gamma(\alpha + 1)$ .

17. Suppose  $f$  is continuous on  $[0, T]$  and  $f(t + T) = f(t)$  for all  $t \geq 0$ . (We say in this case that  $f$  is *periodic with period  $T$* .)

(a) Conclude from Theorem 8.1.6 that the Laplace transform of  $f$  is defined for  $s > 0$ . HINT: Since  $f$  is continuous on  $[0, T]$  and periodic with period  $T$ , it's bounded on  $[0, \infty)$ .

(b) Show that

$$F(s) = \frac{1}{1 - e^{-sT}} \int_0^T e^{-st} f(t) dt, \quad s > 0.$$

HINT: Write

$$F(s) = \sum_{n=0}^{\infty} \int_{nT}^{(n+1)T} e^{-st} f(t) dt.$$

Then show that

$$\int_{nT}^{(n+1)T} e^{-st} f(t) dt = e^{-nsT} \int_0^T e^{-st} f(t) dt,$$

and recall the formula for the sum of a geometric series.

18. Use the formula given in Exercise 17(b) to find the Laplace transforms of the given periodic functions:

$$(a) \quad f(t) = \begin{cases} t, & 0 \leq t < 1, \\ 2 - t, & 1 \leq t < 2, \end{cases} \quad f(t + 2) = f(t), \quad t \geq 0$$

$$(b) \quad f(t) = \begin{cases} 1, & 0 \leq t < \frac{1}{2}, \\ -1, & \frac{1}{2} \leq t < 1, \end{cases} \quad f(t + 1) = f(t), \quad t \geq 0$$

$$(c) \quad f(t) = |\sin t|$$

$$(d) \quad f(t) = \begin{cases} \sin t, & 0 \leq t < \pi, \\ 0, & \pi \leq t < 2\pi, \end{cases} \quad f(t + 2\pi) = f(t)$$

## 8.2 THE INVERSE LAPLACE TRANSFORM

### Definition of the Inverse Laplace Transform

In Section 8.1 we defined the Laplace transform of  $f$  by

$$F(s) = \mathcal{L}(f) = \int_0^{\infty} e^{-st} f(t) dt.$$

We'll also say that  $f$  is an *inverse Laplace Transform* of  $F$ , and write

$$f = \mathcal{L}^{-1}(F).$$

To solve differential equations with the Laplace transform, we must be able to obtain  $f$  from its transform  $F$ . There's a formula for doing this, but we can't use it because it requires the theory of functions of a complex variable. Fortunately, we can use the table of Laplace transforms to find inverse transforms that we'll need.

**Example 8.2.1** Use the table of Laplace transforms to find

$$\text{(a)} \mathcal{L}^{-1}\left(\frac{1}{s^2 - 1}\right) \quad \text{and} \quad \text{(b)} \mathcal{L}^{-1}\left(\frac{s}{s^2 + 9}\right).$$

**SOLUTION(a)** Setting  $b = 1$  in the transform pair

$$\sinh bt \leftrightarrow \frac{b}{s^2 - b^2}$$

shows that

$$\mathcal{L}^{-1}\left(\frac{1}{s^2 - 1}\right) = \sinh t.$$

**SOLUTION(b)** Setting  $\omega = 3$  in the transform pair

$$\cos \omega t \leftrightarrow \frac{s}{s^2 + \omega^2}$$

shows that

$$\mathcal{L}^{-1}\left(\frac{s}{s^2 + 9}\right) = \cos 3t. \quad \blacksquare$$

The next theorem enables us to find inverse transforms of linear combinations of transforms in the table. We omit the proof.

**Theorem 8.2.1** [*Linearity Property*] If  $F_1, F_2, \dots, F_n$  are Laplace transforms and  $c_1, c_2, \dots, c_n$  are constants, then

$$\mathcal{L}^{-1}(c_1 F_1 + c_2 F_2 + \dots + c_n F_n) = c_1 \mathcal{L}^{-1}(F_1) + c_2 \mathcal{L}^{-1}(F_2) + \dots + c_n \mathcal{L}^{-1}(F_n).$$

**Example 8.2.2** Find

$$\mathcal{L}^{-1}\left(\frac{8}{s+5} + \frac{7}{s^2+3}\right).$$

**Solution** From the table of Laplace transforms in Section 8.8.,

$$e^{at} \leftrightarrow \frac{1}{s-a} \quad \text{and} \quad \sin \omega t \leftrightarrow \frac{\omega}{s^2 + \omega^2}.$$

Theorem 8.2.1 with  $a = -5$  and  $\omega = \sqrt{3}$  yields

$$\begin{aligned} \mathcal{L}^{-1}\left(\frac{8}{s+5} + \frac{7}{s^2+3}\right) &= 8\mathcal{L}^{-1}\left(\frac{1}{s+5}\right) + 7\mathcal{L}^{-1}\left(\frac{1}{s^2+3}\right) \\ &= 8\mathcal{L}^{-1}\left(\frac{1}{s+5}\right) + \frac{7}{\sqrt{3}}\mathcal{L}^{-1}\left(\frac{\sqrt{3}}{s^2+3}\right) \\ &= 8e^{-5t} + \frac{7}{\sqrt{3}}\sin \sqrt{3}t. \end{aligned}$$

**Example 8.2.3** Find

$$\mathcal{L}^{-1}\left(\frac{3s+8}{s^2+2s+5}\right).$$

**Solution** Completing the square in the denominator yields

$$\frac{3s+8}{s^2+2s+5} = \frac{3s+8}{(s+1)^2+4}.$$

Because of the form of the denominator, we consider the transform pairs

$$e^{-t} \cos 2t \leftrightarrow \frac{s+1}{(s+1)^2+4} \quad \text{and} \quad e^{-t} \sin 2t \leftrightarrow \frac{2}{(s+1)^2+4},$$

and write

$$\begin{aligned} \mathcal{L}^{-1}\left(\frac{3s+8}{(s+1)^2+4}\right) &= \mathcal{L}^{-1}\left(\frac{3s+3}{(s+1)^2+4}\right) + \mathcal{L}^{-1}\left(\frac{5}{(s+1)^2+4}\right) \\ &= 3\mathcal{L}^{-1}\left(\frac{s+1}{(s+1)^2+4}\right) + \frac{5}{2}\mathcal{L}^{-1}\left(\frac{2}{(s+1)^2+4}\right) \\ &= e^{-t}(3 \cos 2t + \frac{5}{2} \sin 2t). \end{aligned}$$

**REMARK:** We'll often write inverse Laplace transforms of specific functions without explicitly stating how they are obtained. In such cases you should refer to the table of Laplace transforms in Section 8.8.

### Inverse Laplace Transforms of Rational Functions

Using the Laplace transform to solve differential equations often requires finding the inverse transform of a rational function

$$F(s) = \frac{P(s)}{Q(s)},$$

where  $P$  and  $Q$  are polynomials in  $s$  with no common factors. Since it can be shown that  $\lim_{s \rightarrow \infty} F(s) = 0$  if  $F$  is a Laplace transform, we need only consider the case where  $\text{degree}(P) < \text{degree}(Q)$ . To obtain  $\mathcal{L}^{-1}(F)$ , we find the partial fraction expansion of  $F$ , obtain inverse transforms of the individual terms in the expansion from the table of Laplace transforms, and use the linearity property of the inverse transform. The next two examples illustrate this.

**Example 8.2.4** Find the inverse Laplace transform of

$$F(s) = \frac{3s+2}{s^2-3s+2}. \quad (8.2.1)$$

**Solution** (METHOD 1) Factoring the denominator in (8.2.1) yields

$$F(s) = \frac{3s+2}{(s-1)(s-2)}. \quad (8.2.2)$$

The form for the partial fraction expansion is

$$\frac{3s+2}{(s-1)(s-2)} = \frac{A}{s-1} + \frac{B}{s-2}. \quad (8.2.3)$$

Multiplying this by  $(s - 1)(s - 2)$  yields

$$3s + 2 = (s - 2)A + (s - 1)B.$$

Setting  $s = 2$  yields  $B = 8$  and setting  $s = 1$  yields  $A = -5$ . Therefore

$$F(s) = -\frac{5}{s - 1} + \frac{8}{s - 2}$$

and

$$\mathcal{L}^{-1}(F) = -5\mathcal{L}^{-1}\left(\frac{1}{s - 1}\right) + 8\mathcal{L}^{-1}\left(\frac{1}{s - 2}\right) = -5e^t + 8e^{2t}.$$

**Solution** (METHOD 2) We don't really have to multiply (8.2.3) by  $(s - 1)(s - 2)$  to compute  $A$  and  $B$ . We can obtain  $A$  by simply ignoring the factor  $s - 1$  in the denominator of (8.2.2) and setting  $s = 1$  elsewhere; thus,

$$A = \left. \frac{3s + 2}{s - 2} \right|_{s=1} = \frac{3 \cdot 1 + 2}{1 - 2} = -5. \quad (8.2.4)$$

Similarly, we can obtain  $B$  by ignoring the factor  $s - 2$  in the denominator of (8.2.2) and setting  $s = 2$  elsewhere; thus,

$$B = \left. \frac{3s + 2}{s - 1} \right|_{s=2} = \frac{3 \cdot 2 + 2}{2 - 1} = 8. \quad (8.2.5)$$

To justify this, we observe that multiplying (8.2.3) by  $s - 1$  yields

$$\frac{3s + 2}{s - 2} = A + (s - 1)\frac{B}{s - 2},$$

and setting  $s = 1$  leads to (8.2.4). Similarly, multiplying (8.2.3) by  $s - 2$  yields

$$\frac{3s + 2}{s - 1} = (s - 2)\frac{A}{s - 2} + B$$

and setting  $s = 2$  leads to (8.2.5). (It isn't necessary to write the last two equations. We wrote them only to justify the shortcut procedure indicated in (8.2.4) and (8.2.5).) ■

The shortcut employed in the second solution of Example 8.2.4 is *Heaviside's method*. The next theorem states this method formally. For a proof and an extension of this theorem, see Exercise 10.

**Theorem 8.2.2** *Suppose*

$$F(s) = \frac{P(s)}{(s - s_1)(s - s_2) \cdots (s - s_n)}, \quad (8.2.6)$$

where  $s_1, s_2, \dots, s_n$  are distinct and  $P$  is a polynomial of degree less than  $n$ . Then

$$F(s) = \frac{A_1}{s - s_1} + \frac{A_2}{s - s_2} + \cdots + \frac{A_n}{s - s_n},$$

where  $A_i$  can be computed from (8.2.6) by ignoring the factor  $s - s_i$  and setting  $s = s_i$  elsewhere.

**Example 8.2.5** Find the inverse Laplace transform of

$$F(s) = \frac{6 + (s + 1)(s^2 - 5s + 11)}{s(s - 1)(s - 2)(s + 1)}. \quad (8.2.7)$$

**Solution** The partial fraction expansion of (8.2.7) is of the form

$$F(s) = \frac{A}{s} + \frac{B}{s-1} + \frac{C}{s-2} + \frac{D}{s+1}. \quad (8.2.8)$$

To find  $A$ , we ignore the factor  $s$  in the denominator of (8.2.7) and set  $s = 0$  elsewhere. This yields

$$A = \frac{6 + (1)(11)}{(-1)(-2)(1)} = \frac{17}{2}.$$

Similarly, the other coefficients are given by

$$B = \frac{6 + (2)(7)}{(1)(-1)(2)} = -10,$$

$$C = \frac{6 + 3(5)}{2(1)(3)} = \frac{7}{2},$$

and

$$D = \frac{6}{(-1)(-2)(-3)} = -1.$$

Therefore

$$F(s) = \frac{17}{2} \frac{1}{s} - \frac{10}{s-1} + \frac{7}{2} \frac{1}{s-2} - \frac{1}{s+1}$$

and

$$\begin{aligned} \mathcal{L}^{-1}(F) &= \frac{17}{2} \mathcal{L}^{-1}\left(\frac{1}{s}\right) - 10 \mathcal{L}^{-1}\left(\frac{1}{s-1}\right) + \frac{7}{2} \mathcal{L}^{-1}\left(\frac{1}{s-2}\right) - \mathcal{L}^{-1}\left(\frac{1}{s+1}\right) \\ &= \frac{17}{2} - 10e^t + \frac{7}{2}e^{2t} - e^{-t}. \end{aligned}$$

**REMARK:** We didn't "multiply out" the numerator in (8.2.7) before computing the coefficients in (8.2.8), since it wouldn't simplify the computations.

**Example 8.2.6** Find the inverse Laplace transform of

$$F(s) = \frac{8 - (s+2)(4s+10)}{(s+1)(s+2)^2}. \quad (8.2.9)$$

**Solution** The form for the partial fraction expansion is

$$F(s) = \frac{A}{s+1} + \frac{B}{s+2} + \frac{C}{(s+2)^2}. \quad (8.2.10)$$

Because of the repeated factor  $(s+2)^2$  in (8.2.9), Heaviside's method doesn't work. Instead, we find a common denominator in (8.2.10). This yields

$$F(s) = \frac{A(s+2)^2 + B(s+1)(s+2) + C(s+1)}{(s+1)(s+2)^2}. \quad (8.2.11)$$

If (8.2.9) and (8.2.11) are to be equivalent, then

$$A(s+2)^2 + B(s+1)(s+2) + C(s+1) = 8 - (s+2)(4s+10). \quad (8.2.12)$$

The two sides of this equation are polynomials of degree two. From a theorem of algebra, they will be equal for all  $s$  if they are equal for any three distinct values of  $s$ . We may determine  $A$ ,  $B$  and  $C$  by choosing convenient values of  $s$ .

The left side of (8.2.12) suggests that we take  $s = -2$  to obtain  $C = -8$ , and  $s = -1$  to obtain  $A = 2$ . We can now choose any third value of  $s$  to determine  $B$ . Taking  $s = 0$  yields  $4A + 2B + C = -12$ . Since  $A = 2$  and  $C = -8$  this implies that  $B = -6$ . Therefore

$$F(s) = \frac{2}{s+1} - \frac{6}{s+2} - \frac{8}{(s+2)^2}$$

and

$$\begin{aligned}\mathcal{L}^{-1}(F) &= 2\mathcal{L}^{-1}\left(\frac{1}{s+1}\right) - 6\mathcal{L}^{-1}\left(\frac{1}{s+2}\right) - 8\mathcal{L}^{-1}\left(\frac{1}{(s+2)^2}\right) \\ &= 2e^{-t} - 6e^{-2t} - 8te^{-2t}.\end{aligned}$$

**Example 8.2.7** Find the inverse Laplace transform of

$$F(s) = \frac{s^2 - 5s + 7}{(s+2)^3}.$$

**Solution** The form for the partial fraction expansion is

$$F(s) = \frac{A}{s+2} + \frac{B}{(s+2)^2} + \frac{C}{(s+2)^3}.$$

The easiest way to obtain  $A$ ,  $B$ , and  $C$  is to expand the numerator in powers of  $s+2$ . This yields

$$s^2 - 5s + 7 = [(s+2) - 2]^2 - 5[(s+2) - 2] + 7 = (s+2)^2 - 9(s+2) + 21.$$

Therefore

$$\begin{aligned}F(s) &= \frac{(s+2)^2 - 9(s+2) + 21}{(s+2)^3} \\ &= \frac{1}{s+2} - \frac{9}{(s+2)^2} + \frac{21}{(s+2)^3}\end{aligned}$$

and

$$\begin{aligned}\mathcal{L}^{-1}(F) &= \mathcal{L}^{-1}\left(\frac{1}{s+2}\right) - 9\mathcal{L}^{-1}\left(\frac{1}{(s+2)^2}\right) + \frac{21}{2}\mathcal{L}^{-1}\left(\frac{2}{(s+2)^3}\right) \\ &= e^{-2t}\left(1 - 9t + \frac{21}{2}t^2\right).\end{aligned}$$

**Example 8.2.8** Find the inverse Laplace transform of

$$F(s) = \frac{1 - s(5 + 3s)}{s[(s+1)^2 + 1]}. \quad (8.2.13)$$



**Solution** One form for the partial fraction expansion of  $F$  is

$$F(s) = \frac{A}{s} + \frac{Bs + C}{(s+1)^2 + 1}. \quad (8.2.14)$$

However, we see from the table of Laplace transforms that the inverse transform of the second fraction on the right of (8.2.14) will be a linear combination of the inverse transforms

$$e^{-t} \cos t \quad \text{and} \quad e^{-t} \sin t$$

of

$$\frac{s+1}{(s+1)^2 + 1} \quad \text{and} \quad \frac{1}{(s+1)^2 + 1}$$

respectively. Therefore, instead of (8.2.14) we write

$$F(s) = \frac{A}{s} + \frac{B(s+1) + C}{(s+1)^2 + 1}. \quad (8.2.15)$$

Finding a common denominator yields

$$F(s) = \frac{A[(s+1)^2 + 1] + B(s+1)s + Cs}{s[(s+1)^2 + 1]}. \quad (8.2.16)$$

If (8.2.13) and (8.2.16) are to be equivalent, then

$$A[(s+1)^2 + 1] + B(s+1)s + Cs = 1 - s(5+3s).$$

This is true for all  $s$  if it's true for three distinct values of  $s$ . Choosing  $s = 0, -1,$  and  $1$  yields the system

$$\begin{aligned} 2A &= 1 \\ A - C &= 3 \\ 5A + 2B + C &= -7. \end{aligned}$$

Solving this system yields

$$A = \frac{1}{2}, \quad B = -\frac{7}{2}, \quad C = -\frac{5}{2}.$$

Hence, from (8.2.15),

$$F(s) = \frac{1}{2s} - \frac{7}{2} \frac{s+1}{(s+1)^2 + 1} - \frac{5}{2} \frac{1}{(s+1)^2 + 1}.$$

Therefore

$$\begin{aligned} \mathcal{L}^{-1}(F) &= \frac{1}{2} \mathcal{L}^{-1}\left(\frac{1}{s}\right) - \frac{7}{2} \mathcal{L}^{-1}\left(\frac{s+1}{(s+1)^2 + 1}\right) - \frac{5}{2} \mathcal{L}^{-1}\left(\frac{1}{(s+1)^2 + 1}\right) \\ &= \frac{1}{2} - \frac{7}{2} e^{-t} \cos t - \frac{5}{2} e^{-t} \sin t. \end{aligned}$$

**Example 8.2.9** Find the inverse Laplace transform of

$$F(s) = \frac{8 + 3s}{(s^2 + 1)(s^2 + 4)}. \quad (8.2.17)$$

**Solution** The form for the partial fraction expansion is

$$F(s) = \frac{A + Bs}{s^2 + 1} + \frac{C + Ds}{s^2 + 4}.$$

The coefficients  $A$ ,  $B$ ,  $C$  and  $D$  can be obtained by finding a common denominator and equating the resulting numerator to the numerator in (8.2.17). However, since there's no first power of  $s$  in the denominator of (8.2.17), there's an easier way: the expansion of

$$F_1(s) = \frac{1}{(s^2 + 1)(s^2 + 4)}$$

can be obtained quickly by using Heaviside's method to expand

$$\frac{1}{(x + 1)(x + 4)} = \frac{1}{3} \left( \frac{1}{x + 1} - \frac{1}{x + 4} \right)$$

and then setting  $x = s^2$  to obtain

$$\frac{1}{(s^2 + 1)(s^2 + 4)} = \frac{1}{3} \left( \frac{1}{s^2 + 1} - \frac{1}{s^2 + 4} \right).$$

Multiplying this by  $8 + 3s$  yields

$$F(s) = \frac{8 + 3s}{(s^2 + 1)(s^2 + 4)} = \frac{1}{3} \left( \frac{8 + 3s}{s^2 + 1} - \frac{8 + 3s}{s^2 + 4} \right).$$

Therefore

$$\mathcal{L}^{-1}(F) = \frac{8}{3} \sin t + \cos t - \frac{4}{3} \sin 2t - \cos 2t.$$

### USING TECHNOLOGY

Some software packages that do symbolic algebra can find partial fraction expansions very easily. We recommend that you use such a package if one is available to you, but only after you've done enough partial fraction expansions on your own to master the technique.

## 8.2 Exercises

---

1. Use the table of Laplace transforms to find the inverse Laplace transform.

(a)  $\frac{3}{(s - 7)^4}$

(b)  $\frac{2s - 4}{s^2 - 4s + 13}$

(c)  $\frac{1}{s^2 + 4s + 20}$

(d)  $\frac{2}{s^2 + 9}$

(e)  $\frac{s^2 - 1}{(s^2 + 1)^2}$

(f)  $\frac{1}{(s - 2)^2 - 4}$

(g)  $\frac{12s - 24}{(s^2 - 4s + 85)^2}$

(h)  $\frac{2}{(s - 3)^2 - 9}$

(i)  $\frac{s^2 - 4s + 3}{(s^2 - 4s + 5)^2}$

2. Use Theorem 8.2.1 and the table of Laplace transforms to find the inverse Laplace transform.

$$\begin{array}{lll}
 \text{(a)} \frac{2s+3}{(s-7)^4} & \text{(b)} \frac{s^2-1}{(s-2)^6} & \text{(c)} \frac{s+5}{s^2+6s+18} \\
 \text{(d)} \frac{2s+1}{s^2+9} & \text{(e)} \frac{s}{s^2+2s+1} & \text{(f)} \frac{s+1}{s^2-9} \\
 \text{(g)} \frac{s^3+2s^2-s-3}{(s+1)^4} & \text{(h)} \frac{2s+3}{(s-1)^2+4} & \text{(i)} \frac{1}{s} - \frac{s}{s^2+1} \\
 \text{(j)} \frac{3s+4}{s^2-1} & \text{(k)} \frac{3}{s-1} + \frac{4s+1}{s^2+9} & \text{(l)} \frac{3}{(s+2)^2} - \frac{2s+6}{s^2+4}
 \end{array}$$

3. Use Heaviside's method to find the inverse Laplace transform.

$$\begin{array}{ll}
 \text{(a)} \frac{3-(s+1)(s-2)}{(s+1)(s+2)(s-2)} & \text{(b)} \frac{7+(s+4)(18-3s)}{(s-3)(s-1)(s+4)} \\
 \text{(c)} \frac{2+(s-2)(3-2s)}{(s-2)(s+2)(s-3)} & \text{(d)} \frac{3-(s-1)(s+1)}{(s+4)(s-2)(s-1)} \\
 \text{(e)} \frac{3+(s-2)(10-2s-s^2)}{(s-2)(s+2)(s-1)(s+3)} & \text{(f)} \frac{3+(s-3)(2s^2+s-21)}{(s-3)(s-1)(s+4)(s-2)}
 \end{array}$$

4. Find the inverse Laplace transform.

$$\begin{array}{ll}
 \text{(a)} \frac{2+3s}{(s^2+1)(s+2)(s+1)} & \text{(b)} \frac{3s^2+2s+1}{(s^2+1)(s^2+2s+2)} \\
 \text{(c)} \frac{3s+2}{(s-2)(s^2+2s+5)} & \text{(d)} \frac{3s^2+2s+1}{(s-1)^2(s+2)(s+3)} \\
 \text{(e)} \frac{2s^2+s+3}{(s-1)^2(s+2)^2} & \text{(f)} \frac{3s+2}{(s^2+1)(s-1)^2}
 \end{array}$$

5. Use the method of Example 8.2.9 to find the inverse Laplace transform.

$$\begin{array}{lll}
 \text{(a)} \frac{3s+2}{(s^2+4)(s^2+9)} & \text{(b)} \frac{-4s+1}{(s^2+1)(s^2+16)} & \text{(c)} \frac{5s+3}{(s^2+1)(s^2+4)} \\
 \text{(d)} \frac{-s+1}{(4s^2+1)(s^2+1)} & \text{(e)} \frac{17s-34}{(s^2+16)(16s^2+1)} & \text{(f)} \frac{2s-1}{(4s^2+1)(9s^2+1)}
 \end{array}$$

6. Find the inverse Laplace transform.

$$\begin{array}{ll}
 \text{(a)} \frac{17s-15}{(s^2-2s+5)(s^2+2s+10)} & \text{(b)} \frac{8s+56}{(s^2-6s+13)(s^2+2s+5)} \\
 \text{(c)} \frac{s+9}{(s^2+4s+5)(s^2-4s+13)} & \text{(d)} \frac{3s-2}{(s^2-4s+5)(s^2-6s+13)} \\
 \text{(e)} \frac{3s-1}{(s^2-2s+2)(s^2+2s+5)} & \text{(f)} \frac{20s+40}{(4s^2-4s+5)(4s^2+4s+5)}
 \end{array}$$

7. Find the inverse Laplace transform.

$$\begin{array}{ll}
 \text{(a)} \frac{1}{s(s^2+1)} & \text{(b)} \frac{1}{(s-1)(s^2-2s+17)} \\
 \text{(c)} \frac{3s+2}{(s-2)(s^2+2s+10)} & \text{(d)} \frac{34-17s}{(2s-1)(s^2-2s+5)} \\
 \text{(e)} \frac{s+2}{(s-3)(s^2+2s+5)} & \text{(f)} \frac{2s-2}{(s-2)(s^2+2s+10)}
 \end{array}$$

8. Find the inverse Laplace transform.

$$\begin{array}{ll}
 \text{(a)} \frac{2s+1}{(s^2+1)(s-1)(s-3)} & \text{(b)} \frac{s+2}{(s^2+2s+2)(s^2-1)} \\
 \text{(c)} \frac{2s-1}{(s^2-2s+2)(s+1)(s-2)} & \text{(d)} \frac{s-6}{(s^2-1)(s^2+4)} \\
 \text{(e)} \frac{2s-3}{s(s-2)(s^2-2s+5)} & \text{(f)} \frac{5s-15}{(s^2-4s+13)(s-2)(s-1)}
 \end{array}$$

9. Given that  $f(t) \leftrightarrow F(s)$ , find the inverse Laplace transform of  $F(as-b)$ , where  $a > 0$ .
10. (a) If  $s_1, s_2, \dots, s_n$  are distinct and  $P$  is a polynomial of degree less than  $n$ , then

$$\frac{P(s)}{(s-s_1)(s-s_2)\cdots(s-s_n)} = \frac{A_1}{s-s_1} + \frac{A_2}{s-s_2} + \cdots + \frac{A_n}{s-s_n}.$$

Multiply through by  $s-s_i$  to show that  $A_i$  can be obtained by ignoring the factor  $s-s_i$  on the left and setting  $s=s_i$  elsewhere.

- (b) Suppose  $P$  and  $Q_1$  are polynomials such that  $\text{degree}(P) \leq \text{degree}(Q_1)$  and  $Q_1(s_1) \neq 0$ . Show that the coefficient of  $1/(s-s_1)$  in the partial fraction expansion of

$$F(s) = \frac{P(s)}{(s-s_1)Q_1(s)}$$

is  $P(s_1)/Q_1(s_1)$ .

- (c) Explain how the results of (a) and (b) are related.

### 8.3 SOLUTION OF INITIAL VALUE PROBLEMS

#### Laplace Transforms of Derivatives

In the rest of this chapter we'll use the Laplace transform to solve initial value problems for constant coefficient second order equations. To do this, we must know how the Laplace transform of  $f'$  is related to the Laplace transform of  $f$ . The next theorem answers this question.

**Theorem 8.3.1** *Suppose  $f$  is continuous on  $[0, \infty)$  and of exponential order  $s_0$ , and  $f'$  is piecewise continuous on  $[0, \infty)$ . Then  $f$  and  $f'$  have Laplace transforms for  $s > s_0$ , and*

$$\mathcal{L}(f') = s\mathcal{L}(f) - f(0). \quad (8.3.1)$$

#### Proof

We know from Theorem 8.1.6 that  $\mathcal{L}(f)$  is defined for  $s > s_0$ . We first consider the case where  $f'$  is continuous on  $[0, \infty)$ . Integration by parts yields

$$\begin{aligned}
 \int_0^T e^{-st} f'(t) dt &= e^{-st} f(t) \Big|_0^T + s \int_0^T e^{-st} f(t) dt \\
 &= e^{-sT} f(T) - f(0) + s \int_0^T e^{-st} f(t) dt
 \end{aligned} \quad (8.3.2)$$

for any  $T > 0$ . Since  $f$  is of exponential order  $s_0$ ,  $\lim_{T \rightarrow \infty} e^{-sT} f(T) = 0$  and the last integral in (8.3.2) converges as  $T \rightarrow \infty$  if  $s > s_0$ . Therefore

$$\begin{aligned}
 \int_0^\infty e^{-st} f'(t) dt &= -f(0) + s \int_0^\infty e^{-st} f(t) dt \\
 &= -f(0) + s\mathcal{L}(f),
 \end{aligned}$$

which proves (8.3.1). Now suppose  $T > 0$  and  $f'$  is only piecewise continuous on  $[0, T]$ , with discontinuities at  $t_1 < t_2 < \cdots < t_{n-1}$ . For convenience, let  $t_0 = 0$  and  $t_n = T$ . Integrating by parts yields

$$\begin{aligned} \int_{t_{i-1}}^{t_i} e^{-st} f'(t) dt &= e^{-st} f(t) \Big|_{t_{i-1}}^{t_i} + s \int_{t_{i-1}}^{t_i} e^{-st} f(t) dt \\ &= e^{-st_i} f(t_i) - e^{-st_{i-1}} f(t_{i-1}) + s \int_{t_{i-1}}^{t_i} e^{-st} f(t) dt. \end{aligned}$$

Summing both sides of this equation from  $i = 1$  to  $n$  and noting that

$$\begin{aligned} (e^{-st_1} f(t_1) - e^{-st_0} f(t_0)) + (e^{-st_2} f(t_2) - e^{-st_1} f(t_1)) + \cdots + (e^{-st_N} f(t_N) - e^{-st_{N-1}} f(t_{N-1})) \\ = e^{-st_N} f(t_N) - e^{-st_0} f(t_0) = e^{-sT} f(T) - f(0) \end{aligned}$$

yields (8.3.2), so (8.3.1) follows as before.

**Example 8.3.1** In Example 8.1.4 we saw that

$$\mathcal{L}(\cos \omega t) = \frac{s}{s^2 + \omega^2}.$$

Applying (8.3.1) with  $f(t) = \cos \omega t$  shows that

$$\mathcal{L}(-\omega \sin \omega t) = s \frac{s}{s^2 + \omega^2} - 1 = -\frac{\omega^2}{s^2 + \omega^2}.$$

Therefore

$$\mathcal{L}(\sin \omega t) = \frac{\omega}{s^2 + \omega^2},$$

which agrees with the corresponding result obtained in 8.1.4. ■

In Section 2.1 we showed that the solution of the initial value problem

$$y' = ay, \quad y(0) = y_0, \tag{8.3.3}$$

is  $y = y_0 e^{at}$ . We'll now obtain this result by using the Laplace transform.

Let  $Y(s) = \mathcal{L}(y)$  be the Laplace transform of the unknown solution of (8.3.3). Taking Laplace transforms of both sides of (8.3.3) yields

$$\mathcal{L}(y') = \mathcal{L}(ay),$$

which, by Theorem 8.3.1, can be rewritten as

$$s\mathcal{L}(y) - y(0) = a\mathcal{L}(y),$$

or

$$sY(s) - y_0 = aY(s).$$

Solving for  $Y(s)$  yields

$$Y(s) = \frac{y_0}{s - a},$$

so

$$y = \mathcal{L}^{-1}(Y(s)) = \mathcal{L}^{-1}\left(\frac{y_0}{s - a}\right) = y_0 \mathcal{L}^{-1}\left(\frac{1}{s - a}\right) = y_0 e^{at},$$

which agrees with the known result.

We need the next theorem to solve second order differential equations using the Laplace transform.

**Theorem 8.3.2** Suppose  $f$  and  $f'$  are continuous on  $[0, \infty)$  and of exponential order  $s_0$ , and that  $f''$  is piecewise continuous on  $[0, \infty)$ . Then  $f$ ,  $f'$ , and  $f''$  have Laplace transforms for  $s > s_0$ ,

$$\mathcal{L}(f') = s\mathcal{L}(f) - f(0), \quad (8.3.4)$$

and

$$\mathcal{L}(f'') = s^2\mathcal{L}(f) - f'(0) - sf(0). \quad (8.3.5)$$

**Proof** Theorem 8.3.1 implies that  $\mathcal{L}(f')$  exists and satisfies (8.3.4) for  $s > s_0$ . To prove that  $\mathcal{L}(f'')$  exists and satisfies (8.3.5) for  $s > s_0$ , we first apply Theorem 8.3.1 to  $g = f'$ . Since  $g$  satisfies the hypotheses of Theorem 8.3.1, we conclude that  $\mathcal{L}(g')$  is defined and satisfies

$$\mathcal{L}(g') = s\mathcal{L}(g) - g(0)$$

for  $s > s_0$ . However, since  $g' = f''$ , this can be rewritten as

$$\mathcal{L}(f'') = s\mathcal{L}(f') - f'(0).$$

Substituting (8.3.4) into this yields (8.3.5).

### Solving Second Order Equations with the Laplace Transform

We'll now use the Laplace transform to solve initial value problems for second order equations.

**Example 8.3.2** Use the Laplace transform to solve the initial value problem

$$y'' - 6y' + 5y = 3e^{2t}, \quad y(0) = 2, \quad y'(0) = 3. \quad (8.3.6)$$

**Solution** Taking Laplace transforms of both sides of the differential equation in (8.3.6) yields

$$\mathcal{L}(y'' - 6y' + 5y) = \mathcal{L}(3e^{2t}) = \frac{3}{s-2},$$

which we rewrite as

$$\mathcal{L}(y'') - 6\mathcal{L}(y') + 5\mathcal{L}(y) = \frac{3}{s-2}. \quad (8.3.7)$$

Now denote  $\mathcal{L}(y) = Y(s)$ . Theorem 8.3.2 and the initial conditions in (8.3.6) imply that

$$\mathcal{L}(y') = sY(s) - y(0) = sY(s) - 2$$

and

$$\mathcal{L}(y'') = s^2Y(s) - y'(0) - sy(0) = s^2Y(s) - 3 - 2s.$$

Substituting from the last two equations into (8.3.7) yields

$$(s^2Y(s) - 3 - 2s) - 6(sY(s) - 2) + 5Y(s) = \frac{3}{s-2}.$$

Therefore

$$(s^2 - 6s + 5)Y(s) = \frac{3}{s-2} + (3 + 2s) + 6(-2), \quad (8.3.8)$$

so

$$(s-5)(s-1)Y(s) = \frac{3 + (s-2)(2s-9)}{s-2},$$

and

$$Y(s) = \frac{3 + (s-2)(2s-9)}{(s-2)(s-5)(s-1)}.$$

Heaviside's method yields the partial fraction expansion

$$Y(s) = -\frac{1}{s-2} + \frac{1}{2} \frac{1}{s-5} + \frac{5}{2} \frac{1}{s-1},$$

and taking the inverse transform of this yields

$$y = -e^{2t} + \frac{1}{2}e^{5t} + \frac{5}{2}e^t$$

as the solution of (8.3.6). ■

It isn't necessary to write all the steps that we used to obtain (8.3.8). To see how to avoid this, let's apply the method of Example 8.3.2 to the general initial value problem

$$ay'' + by' + cy = f(t), \quad y(0) = k_0, \quad y'(0) = k_1. \quad (8.3.9)$$

Taking Laplace transforms of both sides of the differential equation in (8.3.9) yields

$$a\mathcal{L}(y'') + b\mathcal{L}(y') + c\mathcal{L}(y) = F(s). \quad (8.3.10)$$

Now let  $Y(s) = \mathcal{L}(y)$ . Theorem 8.3.2 and the initial conditions in (8.3.9) imply that

$$\mathcal{L}(y') = sY(s) - k_0 \quad \text{and} \quad \mathcal{L}(y'') = s^2Y(s) - k_1 - k_0s.$$

Substituting these into (8.3.10) yields

$$a(s^2Y(s) - k_1 - k_0s) + b(sY(s) - k_0) + cY(s) = F(s). \quad (8.3.11)$$

The coefficient of  $Y(s)$  on the left is the characteristic polynomial

$$p(s) = as^2 + bs + c$$

of the complementary equation for (8.3.9). Using this and moving the terms involving  $k_0$  and  $k_1$  to the right side of (8.3.11) yields

$$p(s)Y(s) = F(s) + a(k_1 + k_0s) + bk_0. \quad (8.3.12)$$

This equation corresponds to (8.3.8) of Example 8.3.2. Having established the form of this equation in the general case, it is preferable to go directly from the initial value problem to this equation. You may find it easier to remember (8.3.12) rewritten as

$$p(s)Y(s) = F(s) + a(y'(0) + sy(0)) + by(0). \quad (8.3.13)$$

**Example 8.3.3** Use the Laplace transform to solve the initial value problem

$$2y'' + 3y' + y = 8e^{-2t}, \quad y(0) = -4, \quad y'(0) = 2. \quad (8.3.14)$$

**Solution** The characteristic polynomial is

$$p(s) = 2s^2 + 3s + 1 = (2s + 1)(s + 1)$$

and

$$F(s) = \mathcal{L}(8e^{-2t}) = \frac{8}{s+2},$$

so (8.3.13) becomes

$$(2s+1)(s+1)Y(s) = \frac{8}{s+2} + 2(2-4s) + 3(-4).$$

Solving for  $Y(s)$  yields

$$Y(s) = \frac{4(1-(s+2)(s+1))}{(s+1/2)(s+1)(s+2)}.$$

Heaviside's method yields the partial fraction expansion

$$Y(s) = \frac{4}{3} \frac{1}{s+1/2} - \frac{8}{s+1} + \frac{8}{3} \frac{1}{s+2},$$

so the solution of (8.3.14) is

$$y = \mathcal{L}^{-1}(Y(s)) = \frac{4}{3}e^{-t/2} - 8e^{-t} + \frac{8}{3}e^{-2t}$$

(Figure 8.3.1).

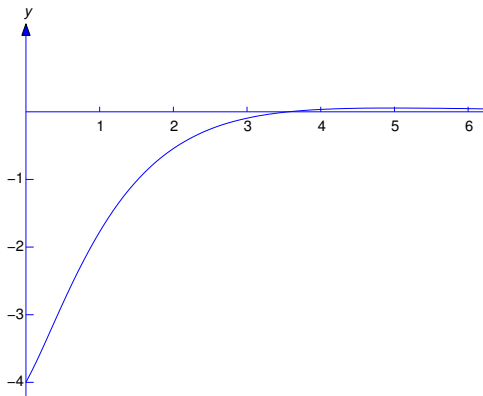

Figure 8.3.1  $y = \frac{4}{3}e^{-t/2} - 8e^{-t} + \frac{8}{3}e^{-2t}$

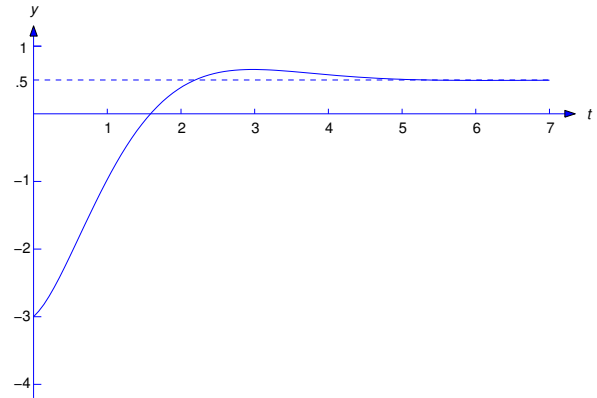

Figure 8.3.2  $y = \frac{1}{2} - \frac{7}{2}e^{-t} \cos t - \frac{5}{2}e^{-t} \sin t$

**Example 8.3.4** Solve the initial value problem

$$y'' + 2y' + 2y = 1, \quad y(0) = -3, \quad y'(0) = 1. \tag{8.3.15}$$

**Solution** The characteristic polynomial is

$$p(s) = s^2 + 2s + 2 = (s+1)^2 + 1$$

and

$$F(s) = \mathcal{L}(1) = \frac{1}{s},$$



so (8.3.13) becomes

$$[(s+1)^2 + 1] Y(s) = \frac{1}{s} + 1 \cdot (1 - 3s) + 2(-3).$$

Solving for  $Y(s)$  yields

$$Y(s) = \frac{1 - s(5 + 3s)}{s[(s+1)^2 + 1]}.$$

In Example 8.2.8 we found the inverse transform of this function to be

$$y = \frac{1}{2} - \frac{7}{2}e^{-t} \cos t - \frac{5}{2}e^{-t} \sin t$$

(Figure 8.3.2), which is therefore the solution of (8.3.15).

**REMARK:** In our examples we applied Theorems 8.3.1 and 8.3.2 without verifying that the unknown function  $y$  satisfies their hypotheses. This is characteristic of the formal manipulative way in which the Laplace transform is used to solve differential equations. Any doubts about the validity of the method for solving a given equation can be resolved by verifying that the resulting function  $y$  is the solution of the given problem.

### 8.3 Exercises

In Exercises 1–31 use the Laplace transform to solve the initial value problem.

1.  $y'' + 3y' + 2y = e^t$ ,  $y(0) = 1$ ,  $y'(0) = -6$
2.  $y'' - y' - 6y = 2$ ,  $y(0) = 1$ ,  $y'(0) = 0$
3.  $y'' + y' - 2y = 2e^{3t}$ ,  $y(0) = -1$ ,  $y'(0) = 4$
4.  $y'' - 4y = 2e^{3t}$ ,  $y(0) = 1$ ,  $y'(0) = -1$
5.  $y'' + y' - 2y = e^{3t}$ ,  $y(0) = 1$ ,  $y'(0) = -1$
6.  $y'' + 3y' + 2y = 6e^t$ ,  $y(0) = 1$ ,  $y'(0) = -1$
7.  $y'' + y = \sin 2t$ ,  $y(0) = 0$ ,  $y'(0) = 1$
8.  $y'' - 3y' + 2y = 2e^{3t}$ ,  $y(0) = 1$ ,  $y'(0) = -1$
9.  $y'' - 3y' + 2y = e^{4t}$ ,  $y(0) = 1$ ,  $y'(0) = -2$
10.  $y'' - 3y' + 2y = e^{3t}$ ,  $y(0) = -1$ ,  $y'(0) = -4$
11.  $y'' + 3y' + 2y = 2e^t$ ,  $y(0) = 0$ ,  $y'(0) = -1$
12.  $y'' + y' - 2y = -4$ ,  $y(0) = 2$ ,  $y'(0) = 3$
13.  $y'' + 4y = 4$ ,  $y(0) = 0$ ,  $y'(0) = 1$
14.  $y'' - y' - 6y = 2$ ,  $y(0) = 1$ ,  $y'(0) = 0$
15.  $y'' + 3y' + 2y = e^t$ ,  $y(0) = 0$ ,  $y'(0) = 1$
16.  $y'' - y = 1$ ,  $y(0) = 1$ ,  $y'(0) = 0$
17.  $y'' + 4y = 3 \sin t$ ,  $y(0) = 1$ ,  $y'(0) = -1$
18.  $y'' + y' = 2e^{3t}$ ,  $y(0) = -1$ ,  $y'(0) = 4$
19.  $y'' + y = 1$ ,  $y(0) = 2$ ,  $y'(0) = 0$
20.  $y'' + y = t$ ,  $y(0) = 0$ ,  $y'(0) = 2$

21.  $y'' + y = t - 3 \sin 2t$ ,  $y(0) = 1$ ,  $y'(0) = -3$   
 22.  $y'' + 5y' + 6y = 2e^{-t}$ ,  $y(0) = 1$ ,  $y'(0) = 3$   
 23.  $y'' + 2y' + y = 6 \sin t - 4 \cos t$ ,  $y(0) = -1$ ,  $y'(0) = 1$   
 24.  $y'' - 2y' - 3y = 10 \cos t$ ,  $y(0) = 2$ ,  $y'(0) = 7$   
 25.  $y'' + y = 4 \sin t + 6 \cos t$ ,  $y(0) = -6$ ,  $y'(0) = 2$   
 26.  $y'' + 4y = 8 \sin 2t + 9 \cos t$ ,  $y(0) = 1$ ,  $y'(0) = 0$   
 27.  $y'' - 5y' + 6y = 10e^t \cos t$ ,  $y(0) = 2$ ,  $y'(0) = 1$   
 28.  $y'' + 2y' + 2y = 2t$ ,  $y(0) = 2$ ,  $y'(0) = -7$   
 29.  $y'' - 2y' + 2y = 5 \sin t + 10 \cos t$ ,  $y(0) = 1$ ,  $y'(0) = 2$   
 30.  $y'' + 4y' + 13y = 10e^{-t} - 36e^t$ ,  $y(0) = 0$ ,  $y'(0) = -16$   
 31.  $y'' + 4y' + 5y = e^{-t}(\cos t + 3 \sin t)$ ,  $y(0) = 0$ ,  $y'(0) = 4$   
 32.  $2y'' - 3y' - 2y = 4e^t$ ,  $y(0) = 1$ ,  $y'(0) = -2$   
 33.  $6y'' - y' - y = 3e^{2t}$ ,  $y(0) = 0$ ,  $y'(0) = 0$   
 34.  $2y'' + 2y' + y = 2t$ ,  $y(0) = 1$ ,  $y'(0) = -1$   
 35.  $4y'' - 4y' + 5y = 4 \sin t - 4 \cos t$ ,  $y(0) = 0$ ,  $y'(0) = 11/17$   
 36.  $4y'' + 4y' + y = 3 \sin t + \cos t$ ,  $y(0) = 2$ ,  $y'(0) = -1$   
 37.  $9y'' + 6y' + y = 3e^{3t}$ ,  $y(0) = 0$ ,  $y'(0) = -3$   
 38. Suppose  $a$ ,  $b$ , and  $c$  are constants and  $a \neq 0$ . Let

$$y_1 = \mathcal{L}^{-1} \left( \frac{as + b}{as^2 + bs + c} \right) \quad \text{and} \quad y_2 = \mathcal{L}^{-1} \left( \frac{a}{as^2 + bs + c} \right).$$

Show that

$$y_1(0) = 1, \quad y_1'(0) = 0 \quad \text{and} \quad y_2(0) = 0, \quad y_2'(0) = 1.$$

HINT: Use the Laplace transform to solve the initial value problems

$$\begin{aligned} ay'' + by' + cy &= 0, & y(0) &= 1, & y'(0) &= 0 \\ ay'' + by' + cy &= 0, & y(0) &= 0, & y'(0) &= 1. \end{aligned}$$

## 8.4 THE UNIT STEP FUNCTION

In the next section we'll consider initial value problems

$$ay'' + by' + cy = f(t), \quad y(0) = k_0, \quad y'(0) = k_1,$$

where  $a$ ,  $b$ , and  $c$  are constants and  $f$  is piecewise continuous. In this section we'll develop procedures for using the table of Laplace transforms to find Laplace transforms of piecewise continuous functions, and to find the piecewise continuous inverses of Laplace transforms.

**Example 8.4.1** Use the table of Laplace transforms to find the Laplace transform of

$$f(t) = \begin{cases} 2t + 1, & 0 \leq t < 2, \\ 3t, & t \geq 2 \end{cases} \quad (8.4.1)$$

(Figure 8.4.1).

**Solution** Since the formula for  $f$  changes at  $t = 2$ , we write

$$\begin{aligned} \mathcal{L}(f) &= \int_0^{\infty} e^{-st} f(t) dt \\ &= \int_0^2 e^{-st} (2t + 1) dt + \int_2^{\infty} e^{-st} (3t) dt. \end{aligned} \quad (8.4.2)$$

To relate the first term to a Laplace transform, we add and subtract

$$\int_2^{\infty} e^{-st} (2t + 1) dt$$

in (8.4.2) to obtain

$$\begin{aligned} \mathcal{L}(f) &= \int_0^{\infty} e^{-st} (2t + 1) dt + \int_2^{\infty} e^{-st} (3t - 2t - 1) dt \\ &= \int_0^{\infty} e^{-st} (2t + 1) dt + \int_2^{\infty} e^{-st} (t - 1) dt \\ &= \mathcal{L}(2t + 1) + \int_2^{\infty} e^{-st} (t - 1) dt. \end{aligned} \quad (8.4.3)$$

To relate the last integral to a Laplace transform, we make the change of variable  $x = t - 2$  and rewrite the integral as

$$\begin{aligned} \int_2^{\infty} e^{-st} (t - 1) dt &= \int_0^{\infty} e^{-s(x+2)} (x + 1) dx \\ &= e^{-2s} \int_0^{\infty} e^{-sx} (x + 1) dx. \end{aligned}$$

Since the symbol used for the variable of integration has no effect on the value of a definite integral, we can now replace  $x$  by the more standard  $t$  and write

$$\int_2^{\infty} e^{-st} (t - 1) dt = e^{-2s} \int_0^{\infty} e^{-st} (t + 1) dt = e^{-2s} \mathcal{L}(t + 1).$$

This and (8.4.3) imply that

$$\mathcal{L}(f) = \mathcal{L}(2t + 1) + e^{-2s} \mathcal{L}(t + 1).$$

Now we can use the table of Laplace transforms to find that

$$\mathcal{L}(f) = \frac{2}{s^2} + \frac{1}{s} + e^{-2s} \left( \frac{1}{s^2} + \frac{1}{s} \right). \blacksquare$$

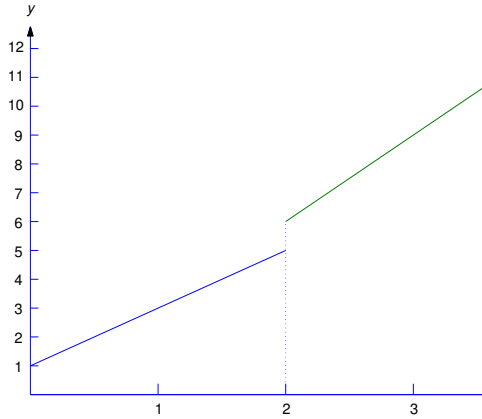

Figure 8.4.1 The piecewise continuous function (8.4.1)

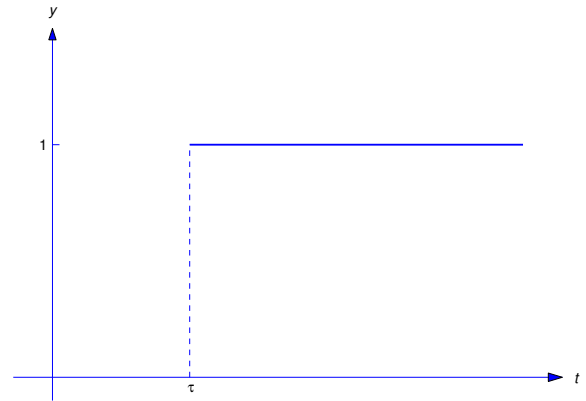

Figure 8.4.2  $y = u(t - \tau)$

### Laplace Transforms of Piecewise Continuous Functions

We'll now develop the method of Example 8.4.1 into a systematic way to find the Laplace transform of a piecewise continuous function. It is convenient to introduce the *unit step function*, defined as

$$u(t) = \begin{cases} 0, & t < 0 \\ 1, & t \geq 0. \end{cases} \quad (8.4.4)$$

Thus,  $u(t)$  “steps” from the constant value 0 to the constant value 1 at  $t = 0$ . If we replace  $t$  by  $t - \tau$  in (8.4.4), then

$$u(t - \tau) = \begin{cases} 0, & t < \tau, \\ 1, & t \geq \tau \end{cases};$$

that is, the step now occurs at  $t = \tau$  (Figure 8.4.2).

The step function enables us to represent piecewise continuous functions conveniently. For example, consider the function

$$f(t) = \begin{cases} f_0(t), & 0 \leq t < t_1, \\ f_1(t), & t \geq t_1, \end{cases} \quad (8.4.5)$$

where we assume that  $f_0$  and  $f_1$  are defined on  $[0, \infty)$ , even though they equal  $f$  only on the indicated intervals. This assumption enables us to rewrite (8.4.5) as

$$f(t) = f_0(t) + u(t - t_1)(f_1(t) - f_0(t)). \quad (8.4.6)$$

To verify this, note that if  $t < t_1$  then  $u(t - t_1) = 0$  and (8.4.6) becomes

$$f(t) = f_0(t) + (0)(f_1(t) - f_0(t)) = f_0(t).$$

If  $t \geq t_1$  then  $u(t - t_1) = 1$  and (8.4.6) becomes

$$f(t) = f_0(t) + (1)(f_1(t) - f_0(t)) = f_1(t).$$

We need the next theorem to show how (8.4.6) can be used to find  $\mathcal{L}(f)$ .

**Theorem 8.4.1** Let  $g$  be defined on  $[0, \infty)$ . Suppose  $\tau \geq 0$  and  $\mathcal{L}(g(t + \tau))$  exists for  $s > s_0$ . Then  $\mathcal{L}(u(t - \tau)g(t))$  exists for  $s > s_0$ , and

$$\mathcal{L}(u(t - \tau)g(t)) = e^{-s\tau} \mathcal{L}(g(t + \tau)).$$

**Proof** By definition,

$$\mathcal{L}(u(t - \tau)g(t)) = \int_0^{\infty} e^{-st} u(t - \tau)g(t) dt.$$

From this and the definition of  $u(t - \tau)$ ,

$$\mathcal{L}(u(t - \tau)g(t)) = \int_0^{\tau} e^{-st}(0) dt + \int_{\tau}^{\infty} e^{-st}g(t) dt.$$

The first integral on the right equals zero. Introducing the new variable of integration  $x = t - \tau$  in the second integral yields

$$\mathcal{L}(u(t - \tau)g(t)) = \int_0^{\infty} e^{-s(x+\tau)}g(x + \tau) dx = e^{-s\tau} \int_0^{\infty} e^{-sx}g(x + \tau) dx.$$

Changing the name of the variable of integration in the last integral from  $x$  to  $t$  yields

$$\mathcal{L}(u(t - \tau)g(t)) = e^{-s\tau} \int_0^{\infty} e^{-st}g(t + \tau) dt = e^{-s\tau} \mathcal{L}(g(t + \tau)). \blacksquare$$

**Example 8.4.2** Find

$$\mathcal{L}(u(t - 1)(t^2 + 1)).$$

**Solution** Here  $\tau = 1$  and  $g(t) = t^2 + 1$ , so

$$g(t + 1) = (t + 1)^2 + 1 = t^2 + 2t + 2.$$

Since

$$\mathcal{L}(g(t + 1)) = \frac{2}{s^3} + \frac{2}{s^2} + \frac{2}{s},$$

Theorem 8.4.1 implies that

$$\mathcal{L}(u(t - 1)(t^2 + 1)) = e^{-s} \left( \frac{2}{s^3} + \frac{2}{s^2} + \frac{2}{s} \right).$$

**Example 8.4.3** Use Theorem 8.4.1 to find the Laplace transform of the function

$$f(t) = \begin{cases} 2t + 1, & 0 \leq t < 2, \\ 3t, & t \geq 2, \end{cases}$$

from Example 8.4.1.

**Solution** We first write  $f$  in the form (8.4.6) as

$$f(t) = 2t + 1 + u(t - 2)(t - 1).$$

Therefore

$$\begin{aligned}\mathcal{L}(f) &= \mathcal{L}(2t + 1) + \mathcal{L}(u(t - 2)(t - 1)) \\ &= \mathcal{L}(2t + 1) + e^{-2s}\mathcal{L}(t + 1) \quad (\text{from Theorem 8.4.1}) \\ &= \frac{2}{s^2} + \frac{1}{s} + e^{-2s} \left( \frac{1}{s^2} + \frac{1}{s} \right),\end{aligned}$$

which is the result obtained in Example 8.4.1. ■

Formula (8.4.6) can be extended to more general piecewise continuous functions. For example, we can write

$$f(t) = \begin{cases} f_0(t), & 0 \leq t < t_1, \\ f_1(t), & t_1 \leq t < t_2, \\ f_2(t), & t \geq t_2, \end{cases}$$

as

$$f(t) = f_0(t) + u(t - t_1)(f_1(t) - f_0(t)) + u(t - t_2)(f_2(t) - f_1(t))$$

if  $f_0$ ,  $f_1$ , and  $f_2$  are all defined on  $[0, \infty)$ .

**Example 8.4.4** Find the Laplace transform of

$$f(t) = \begin{cases} 1, & 0 \leq t < 2, \\ -2t + 1, & 2 \leq t < 3, \\ 3t, & 3 \leq t < 5, \\ t - 1, & t \geq 5 \end{cases} \quad (8.4.7)$$

(Figure 8.4.3).

**Solution** In terms of step functions,

$$\begin{aligned}f(t) &= 1 + u(t - 2)(-2t + 1 - 1) + u(t - 3)(3t + 2t - 1) \\ &\quad + u(t - 5)(t - 1 - 3t),\end{aligned}$$

or

$$f(t) = 1 - 2u(t - 2)t + u(t - 3)(5t - 1) - u(t - 5)(2t + 1).$$

Now Theorem 8.4.1 implies that

$$\begin{aligned}\mathcal{L}(f) &= \mathcal{L}(1) - 2e^{-2s}\mathcal{L}(t + 2) + e^{-3s}\mathcal{L}(5(t + 3) - 1) - e^{-5s}\mathcal{L}(2(t + 5) + 1) \\ &= \mathcal{L}(1) - 2e^{-2s}\mathcal{L}(t + 2) + e^{-3s}\mathcal{L}(5t + 14) - e^{-5s}\mathcal{L}(2t + 11) \\ &= \frac{1}{s} - 2e^{-2s} \left( \frac{1}{s^2} + \frac{2}{s} \right) + e^{-3s} \left( \frac{5}{s^2} + \frac{14}{s} \right) - e^{-5s} \left( \frac{2}{s^2} + \frac{11}{s} \right). \quad \blacksquare\end{aligned}$$

The trigonometric identities

$$\sin(A + B) = \sin A \cos B + \cos A \sin B \quad (8.4.8)$$

$$\cos(A + B) = \cos A \cos B - \sin A \sin B \quad (8.4.9)$$

are useful in problems that involve shifting the arguments of trigonometric functions. We'll use these identities in the next example.

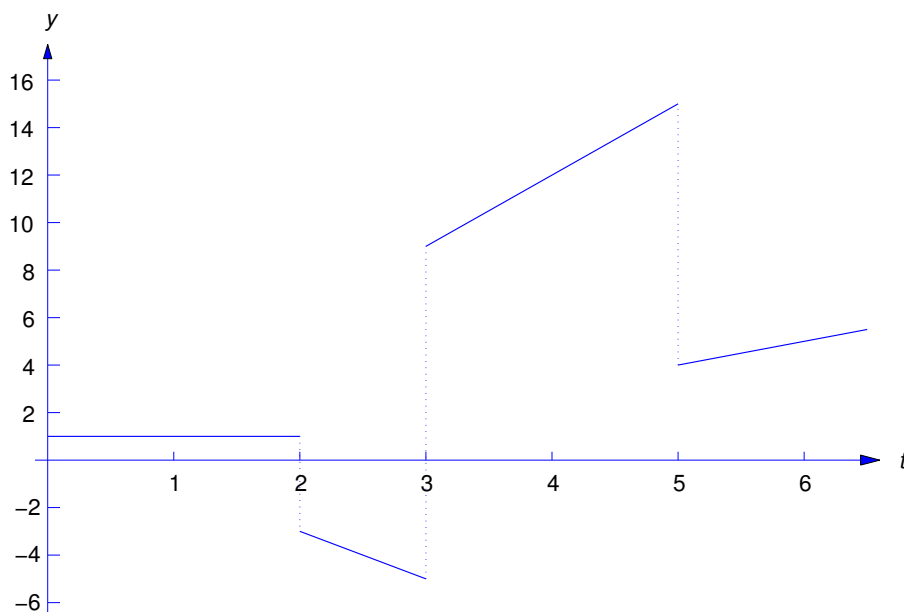

Figure 8.4.3 The piecewise continuous function (8.4.7)

**Example 8.4.5** Find the Laplace transform of

$$f(t) = \begin{cases} \sin t, & 0 \leq t < \frac{\pi}{2}, \\ \cos t - 3 \sin t, & \frac{\pi}{2} \leq t < \pi, \\ 3 \cos t, & t \geq \pi \end{cases} \quad (8.4.10)$$

(Figure 8.4.4).

**Solution** In terms of step functions,

$$f(t) = \sin t + u(t - \pi/2)(\cos t - 4 \sin t) + u(t - \pi)(2 \cos t + 3 \sin t).$$

Now Theorem 8.4.1 implies that

$$\begin{aligned} \mathcal{L}(f) &= \mathcal{L}(\sin t) + e^{-\frac{\pi}{2}s} \mathcal{L}(\cos(t + \frac{\pi}{2}) - 4 \sin(t + \frac{\pi}{2})) \\ &\quad + e^{-\pi s} \mathcal{L}(2 \cos(t + \pi) + 3 \sin(t + \pi)). \end{aligned} \quad (8.4.11)$$

Since

$$\cos\left(t + \frac{\pi}{2}\right) - 4 \sin\left(t + \frac{\pi}{2}\right) = -\sin t - 4 \cos t$$

and

$$2 \cos(t + \pi) + 3 \sin(t + \pi) = -2 \cos t - 3 \sin t,$$

we see from (8.4.11) that

$$\begin{aligned} \mathcal{L}(f) &= \mathcal{L}(\sin t) - e^{-\frac{\pi}{2}s} \mathcal{L}(\sin t + 4 \cos t) - e^{-\pi s} \mathcal{L}(2 \cos t + 3 \sin t) \\ &= \frac{1}{s^2 + 1} - e^{-\frac{\pi}{2}s} \left( \frac{1 + 4s}{s^2 + 1} \right) - e^{-\pi s} \left( \frac{3 + 2s}{s^2 + 1} \right). \blacksquare \end{aligned}$$

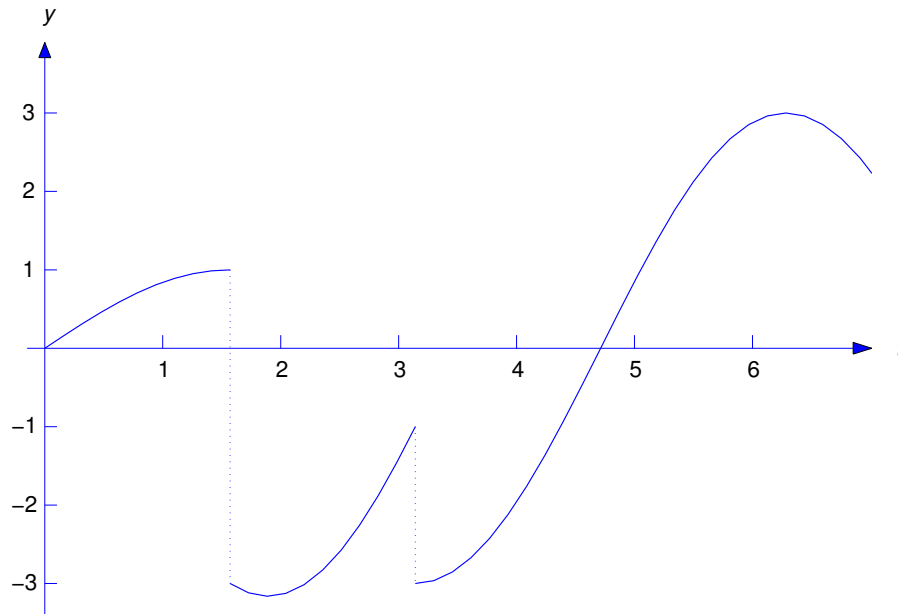

Figure 8.4.4 The piecewise continuous function (8.4.10)

### The Second Shifting Theorem

Replacing  $g(t)$  by  $g(t - \tau)$  in Theorem 8.4.1 yields the next theorem.

**Theorem 8.4.2** [Second Shifting Theorem] If  $\tau \geq 0$  and  $\mathcal{L}(g)$  exists for  $s > s_0$  then  $\mathcal{L}(u(t - \tau)g(t - \tau))$  exists for  $s > s_0$  and

$$\mathcal{L}(u(t - \tau)g(t - \tau)) = e^{-s\tau} \mathcal{L}(g(t)),$$

or, equivalently,

$$\text{if } g(t) \leftrightarrow G(s), \text{ then } u(t - \tau)g(t - \tau) \leftrightarrow e^{-s\tau} G(s). \quad (8.4.12)$$

**REMARK:** Recall that the First Shifting Theorem (Theorem 8.1.3 states that multiplying a function by  $e^{at}$  corresponds to shifting the argument of its transform by  $a$  units. Theorem 8.4.2 states that multiplying a Laplace transform by the exponential  $e^{-\tau s}$  corresponds to shifting the argument of the inverse transform by  $\tau$  units.

**Example 8.4.6** Use (8.4.12) to find

$$\mathcal{L}^{-1} \left( \frac{e^{-2s}}{s^2} \right).$$

**Solution** To apply (8.4.12) we let  $\tau = 2$  and  $G(s) = 1/s^2$ . Then  $g(t) = t$  and (8.4.12) implies that

$$\mathcal{L}^{-1} \left( \frac{e^{-2s}}{s^2} \right) = u(t - 2)(t - 2). \quad \blacksquare$$



**Example 8.4.7** Find the inverse Laplace transform  $h$  of

$$H(s) = \frac{1}{s^2} - e^{-s} \left( \frac{1}{s^2} + \frac{2}{s} \right) + e^{-4s} \left( \frac{4}{s^3} + \frac{1}{s} \right),$$

and find distinct formulas for  $h$  on appropriate intervals.

**Solution** Let

$$G_0(s) = \frac{1}{s^2}, \quad G_1(s) = \frac{1}{s^2} + \frac{2}{s}, \quad G_2(s) = \frac{4}{s^3} + \frac{1}{s}.$$

Then

$$g_0(t) = t, \quad g_1(t) = t + 2, \quad g_2(t) = 2t^2 + 1.$$

Hence, (8.4.12) and the linearity of  $\mathcal{L}^{-1}$  imply that

$$\begin{aligned} h(t) &= \mathcal{L}^{-1}(G_0(s)) - \mathcal{L}^{-1}(e^{-s}G_1(s)) + \mathcal{L}^{-1}(e^{-4s}G_2(s)) \\ &= t - u(t-1)[(t-1)+2] + u(t-4)[2(t-4)^2+1] \\ &= t - u(t-1)(t+1) + u(t-4)(2t^2 - 16t + 33), \end{aligned}$$

which can also be written as

$$h(t) = \begin{cases} t, & 0 \leq t < 1, \\ -1, & 1 \leq t < 4, \quad \blacksquare \\ 2t^2 - 16t + 32, & t \geq 4. \end{cases}$$

**Example 8.4.8** Find the inverse transform of

$$H(s) = \frac{2s}{s^2+4} - e^{-\frac{\pi}{2}s} \frac{3s+1}{s^2+9} + e^{-\pi s} \frac{s+1}{s^2+6s+10}.$$

**Solution** Let

$$G_0(s) = \frac{2s}{s^2+4}, \quad G_1(s) = -\frac{(3s+1)}{s^2+9},$$

and

$$G_2(s) = \frac{s+1}{s^2+6s+10} = \frac{(s+3)-2}{(s+3)^2+1}.$$

Then

$$g_0(t) = 2 \cos 2t, \quad g_1(t) = -3 \cos 3t - \frac{1}{3} \sin 3t,$$

and

$$g_2(t) = e^{-3t}(\cos t - 2 \sin t).$$

Therefore (8.4.12) and the linearity of  $\mathcal{L}^{-1}$  imply that

$$\begin{aligned} h(t) &= 2 \cos 2t - u(t-\pi/2) \left[ 3 \cos 3(t-\pi/2) + \frac{1}{3} \sin 3 \left( t - \frac{\pi}{2} \right) \right] \\ &\quad + u(t-\pi) e^{-3(t-\pi)} [\cos(t-\pi) - 2 \sin(t-\pi)]. \end{aligned}$$

Using the trigonometric identities (8.4.8) and (8.4.9), we can rewrite this as

$$h(t) = 2 \cos 2t + u(t - \pi/2) \left( 3 \sin 3t - \frac{1}{3} \cos 3t \right) - u(t - \pi) e^{-3(t-\pi)} (\cos t - 2 \sin t) \quad (8.4.13)$$

(Figure 8.4.5).

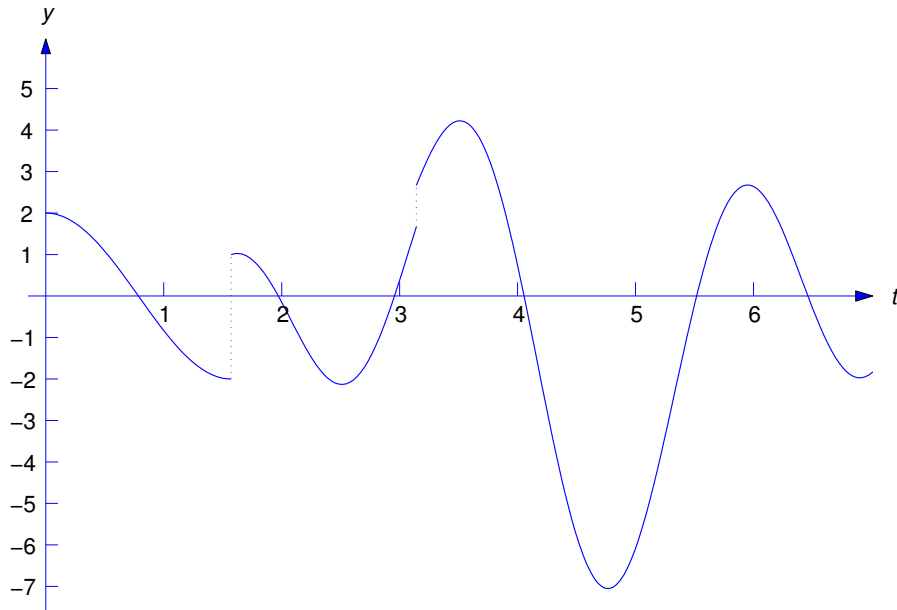

Figure 8.4.5 The piecewise continuous function (8.4.13)

## 8.4 Exercises

In Exercises 1–6 find the Laplace transform by the method of Example 8.4.1. Then express the given function  $f$  in terms of unit step functions as in Eqn. (8.4.6), and use Theorem 8.4.1 to find  $\mathcal{L}(f)$ . Where indicated by C/G, graph  $f$ .

1.  $f(t) = \begin{cases} 1, & 0 \leq t < 4, \\ t, & t \geq 4. \end{cases}$
2.  $f(t) = \begin{cases} t, & 0 \leq t < 1, \\ 1, & t \geq 1. \end{cases}$
3. C/G  $f(t) = \begin{cases} 2t - 1, & 0 \leq t < 2, \\ t, & t \geq 2. \end{cases}$
4. C/G  $f(t) = \begin{cases} 1, & 0 \leq t < 1, \\ t + 2, & t \geq 1. \end{cases}$
5.  $f(t) = \begin{cases} t - 1, & 0 \leq t < 2, \\ 4, & t \geq 2. \end{cases}$
6.  $f(t) = \begin{cases} t^2, & 0 \leq t < 1, \\ 0, & t \geq 1. \end{cases}$

In Exercises 7–18 express the given function  $f$  in terms of unit step functions and use Theorem 8.4.1 to find  $\mathcal{L}(f)$ . Where indicated by  $\boxed{\text{C/G}}$ , graph  $f$ .

$$7. f(t) = \begin{cases} 0, & 0 \leq t < 2, \\ t^2 + 3t, & t \geq 2. \end{cases} \quad 8. f(t) = \begin{cases} t^2 + 2, & 0 \leq t < 1, \\ t, & t \geq 1. \end{cases}$$

$$9. f(t) = \begin{cases} te^t, & 0 \leq t < 1, \\ e^t, & t \geq 1. \end{cases} \quad 10. f(t) = \begin{cases} e^{-t}, & 0 \leq t < 1, \\ e^{-2t}, & t \geq 1. \end{cases}$$

$$11. f(t) = \begin{cases} -t, & 0 \leq t < 2, \\ t - 4, & 2 \leq t < 3, \\ 1, & t \geq 3. \end{cases} \quad 12. f(t) = \begin{cases} 0, & 0 \leq t < 1, \\ t, & 1 \leq t < 2, \\ 0, & t \geq 2. \end{cases}$$

$$13. f(t) = \begin{cases} t, & 0 \leq t < 1, \\ t^2, & 1 \leq t < 2, \\ 0, & t \geq 2. \end{cases} \quad 14. f(t) = \begin{cases} t, & 0 \leq t < 1, \\ 2 - t, & 1 \leq t < 2, \\ 6, & t > 2. \end{cases}$$

$$15. \boxed{\text{C/G}} f(t) = \begin{cases} \sin t, & 0 \leq t < \frac{\pi}{2}, \\ 2 \sin t, & \frac{\pi}{2} \leq t < \pi, \\ \cos t, & t \geq \pi. \end{cases}$$

$$16. \boxed{\text{C/G}} f(t) = \begin{cases} 2, & 0 \leq t < 1, \\ -2t + 2, & 1 \leq t < 3, \\ 3t, & t \geq 3. \end{cases}$$

$$17. \boxed{\text{C/G}} f(t) = \begin{cases} 3, & 0 \leq t < 2, \\ 3t + 2, & 2 \leq t < 4, \\ 4t, & t \geq 4. \end{cases}$$

$$18. \boxed{\text{C/G}} f(t) = \begin{cases} (t+1)^2, & 0 \leq t < 1, \\ (t+2)^2, & t \geq 1. \end{cases}$$

In Exercises 19–28 use Theorem 8.4.2 to express the inverse transforms in terms of step functions, and then find distinct formulas for the inverse transforms on the appropriate intervals, as in Example 8.4.7. Where indicated by  $\boxed{\text{C/G}}$ , graph the inverse transform.

$$19. H(s) = \frac{e^{-2s}}{s-2}$$

$$20. H(s) = \frac{e^{-s}}{s(s+1)}$$

$$21. \boxed{\text{C/G}} H(s) = \frac{e^{-s}}{s^3} + \frac{e^{-2s}}{s^2}$$

$$22. \boxed{\text{C/G}} H(s) = \left(\frac{2}{s} + \frac{1}{s^2}\right) + e^{-s} \left(\frac{3}{s} - \frac{1}{s^2}\right) + e^{-3s} \left(\frac{1}{s} + \frac{1}{s^2}\right)$$

$$23. \quad H(s) = \left(\frac{5}{s} - \frac{1}{s^2}\right) + e^{-3s} \left(\frac{6}{s} + \frac{7}{s^2}\right) + \frac{3e^{-6s}}{s^3}$$

$$24. \quad H(s) = \frac{e^{-\pi s}(1-2s)}{s^2 + 4s + 5}$$

$$25. \quad \boxed{\text{C/G}} \quad H(s) = \left(\frac{1}{s} - \frac{s}{s^2 + 1}\right) + e^{-\frac{\pi}{2}s} \left(\frac{3s-1}{s^2 + 1}\right)$$

$$26. \quad H(s) = e^{-2s} \left[ \frac{3(s-3)}{(s+1)(s-2)} - \frac{s+1}{(s-1)(s-2)} \right]$$

$$27. \quad H(s) = \frac{1}{s} + \frac{1}{s^2} + e^{-s} \left(\frac{3}{s} + \frac{2}{s^2}\right) + e^{-3s} \left(\frac{4}{s} + \frac{3}{s^2}\right)$$

$$28. \quad H(s) = \frac{1}{s} - \frac{2}{s^3} + e^{-2s} \left(\frac{3}{s} - \frac{1}{s^3}\right) + \frac{e^{-4s}}{s^2}$$

29. Find  $\mathcal{L}(u(t-\tau))$ .

30. Let  $\{t_m\}_{m=0}^{\infty}$  be a sequence of points such that  $t_0 = 0$ ,  $t_{m+1} > t_m$ , and  $\lim_{m \rightarrow \infty} t_m = \infty$ . For each nonnegative integer  $m$ , let  $f_m$  be continuous on  $[t_m, \infty)$ , and let  $f$  be defined on  $[0, \infty)$  by

$$f(t) = f_m(t), \quad t_m \leq t < t_{m+1} \quad (m = 0, 1, \dots).$$

Show that  $f$  is piecewise continuous on  $[0, \infty)$  and that it has the step function representation

$$f(t) = f_0(t) + \sum_{m=1}^{\infty} u(t-t_m)(f_m(t) - f_{m-1}(t)), \quad 0 \leq t < \infty.$$

How do we know that the series on the right converges for all  $t$  in  $[0, \infty)$ ?

31. In addition to the assumptions of Exercise 30, assume that

$$|f_m(t)| \leq Me^{s_0 t}, \quad t \geq t_m, \quad m = 0, 1, \dots, \quad (\text{A})$$

and that the series

$$\sum_{m=0}^{\infty} e^{-\rho t_m} \quad (\text{B})$$

converges for some  $\rho > 0$ . Using the steps listed below, show that  $\mathcal{L}(f)$  is defined for  $s > s_0$  and

$$\mathcal{L}(f) = \mathcal{L}(f_0) + \sum_{m=1}^{\infty} e^{-st_m} \mathcal{L}(g_m) \quad (\text{C})$$

for  $s > s_0 + \rho$ , where

$$g_m(t) = f_m(t+t_m) - f_{m-1}(t+t_m).$$

(a) Use (A) and Theorem 8.1.6 to show that

$$\mathcal{L}(f) = \sum_{m=0}^{\infty} \int_{t_m}^{t_{m+1}} e^{-st} f_m(t) dt \quad (\text{D})$$

is defined for  $s > s_0$ .

(b) Show that (D) can be rewritten as

$$\mathcal{L}(f) = \sum_{m=0}^{\infty} \left( \int_{t_m}^{\infty} e^{-st} f_m(t) dt - \int_{t_{m+1}}^{\infty} e^{-st} f_m(t) dt \right). \quad (\text{E})$$

(c) Use (A), the assumed convergence of (B), and the comparison test to show that the series

$$\sum_{m=0}^{\infty} \int_{t_m}^{\infty} e^{-st} f_m(t) dt \quad \text{and} \quad \sum_{m=0}^{\infty} \int_{t_{m+1}}^{\infty} e^{-st} f_m(t) dt$$

both converge (absolutely) if  $s > s_0 + \rho$ .

(d) Show that (E) can be rewritten as

$$\mathcal{L}(f) = \mathcal{L}(f_0) + \sum_{m=1}^{\infty} \int_{t_m}^{\infty} e^{-st} (f_m(t) - f_{m-1}(t)) dt$$

if  $s > s_0 + \rho$ .

(e) Complete the proof of (C).

32. Suppose  $\{t_m\}_{m=0}^{\infty}$  and  $\{f_m\}_{m=0}^{\infty}$  satisfy the assumptions of Exercises 30 and 31, and there's a positive constant  $K$  such that  $t_m \geq Km$  for  $m$  sufficiently large. Show that the series (B) of Exercise 31 converges for any  $\rho > 0$ , and conclude from this that (C) of Exercise 31 holds for  $s > s_0$ .

In Exercises 33–36 find the step function representation of  $f$  and use the result of Exercise 32 to find  $\mathcal{L}(f)$ . HINT: You will need formulas related to the formula for the sum of a geometric series.

33.  $f(t) = m + 1$ ,  $m \leq t < m + 1$  ( $m = 0, 1, 2, \dots$ )  
 34.  $f(t) = (-1)^m$ ,  $m \leq t < m + 1$  ( $m = 0, 1, 2, \dots$ )  
 35.  $f(t) = (m + 1)^2$ ,  $m \leq t < m + 1$  ( $m = 0, 1, 2, \dots$ )  
 36.  $f(t) = (-1)^m m$ ,  $m \leq t < m + 1$  ( $m = 0, 1, 2, \dots$ )

## 8.5 CONSTANT COEFFICIENT EQUATIONS WITH PIECEWISE CONTINUOUS FORCING FUNCTIONS

We'll now consider initial value problems of the form

$$ay'' + by' + cy = f(t), \quad y(0) = k_0, \quad y'(0) = k_1, \quad (8.5.1)$$

where  $a$ ,  $b$ , and  $c$  are constants ( $a \neq 0$ ) and  $f$  is piecewise continuous on  $[0, \infty)$ . Problems of this kind occur in situations where the input to a physical system undergoes instantaneous changes, as when a switch is turned on or off or the forces acting on the system change abruptly.

It can be shown (Exercises 23 and 24) that the differential equation in (8.5.1) has no solutions on an open interval that contains a jump discontinuity of  $f$ . Therefore we must define what we mean by a solution of (8.5.1) on  $[0, \infty)$  in the case where  $f$  has jump discontinuities. The next theorem motivates our definition. We omit the proof.

**Theorem 8.5.1** Suppose  $a, b,$  and  $c$  are constants ( $a \neq 0$ ), and  $f$  is piecewise continuous on  $[0, \infty)$ , with jump discontinuities at  $t_1, \dots, t_n$ , where

$$0 < t_1 < \dots < t_n.$$

Let  $k_0$  and  $k_1$  be arbitrary real numbers. Then there is a unique function  $y$  defined on  $[0, \infty)$  with these properties:

- (a)  $y(0) = k_0$  and  $y'(0) = k_1$ .
- (b)  $y$  and  $y'$  are continuous on  $[0, \infty)$ .
- (c)  $y''$  is defined on every open subinterval of  $[0, \infty)$  that does not contain any of the points  $t_1, \dots, t_n$ , and

$$ay'' + by' + cy = f(t)$$

on every such subinterval.

- (d)  $y''$  has limits from the right and left at  $t_1, \dots, t_n$ .

We define the function  $y$  of Theorem 8.5.1 to be the solution of the initial value problem (8.5.1).

We begin by considering initial value problems of the form

$$ay'' + by' + cy = \begin{cases} f_0(t), & 0 \leq t < t_1, \\ f_1(t), & t \geq t_1, \end{cases} \quad y(0) = k_0, \quad y'(0) = k_1, \quad (8.5.2)$$

where the forcing function has a single jump discontinuity at  $t_1$ .

We can solve (8.5.2) by the these steps:

**Step 1.** Find the solution  $y_0$  of the initial value problem

$$ay'' + by' + cy = f_0(t), \quad y(0) = k_0, \quad y'(0) = k_1.$$

**Step 2.** Compute  $c_0 = y_0(t_1)$  and  $c_1 = y'_0(t_1)$ .

**Step 3.** Find the solution  $y_1$  of the initial value problem

$$ay'' + by' + cy = f_1(t), \quad y(t_1) = c_0, \quad y'(t_1) = c_1.$$

**Step 4.** Obtain the solution  $y$  of (8.5.2) as

$$y = \begin{cases} y_0(t), & 0 \leq t < t_1 \\ y_1(t), & t \geq t_1. \end{cases}$$

It is shown in Exercise 23 that  $y'$  exists and is continuous at  $t_1$ . The next example illustrates this procedure.

**Example 8.5.1** Solve the initial value problem

$$y'' + y = f(t), \quad y(0) = 2, \quad y'(0) = -1, \quad (8.5.3)$$

where

$$f(t) = \begin{cases} 1, & 0 \leq t < \frac{\pi}{2}, \\ -1, & t \geq \frac{\pi}{2}. \end{cases}$$

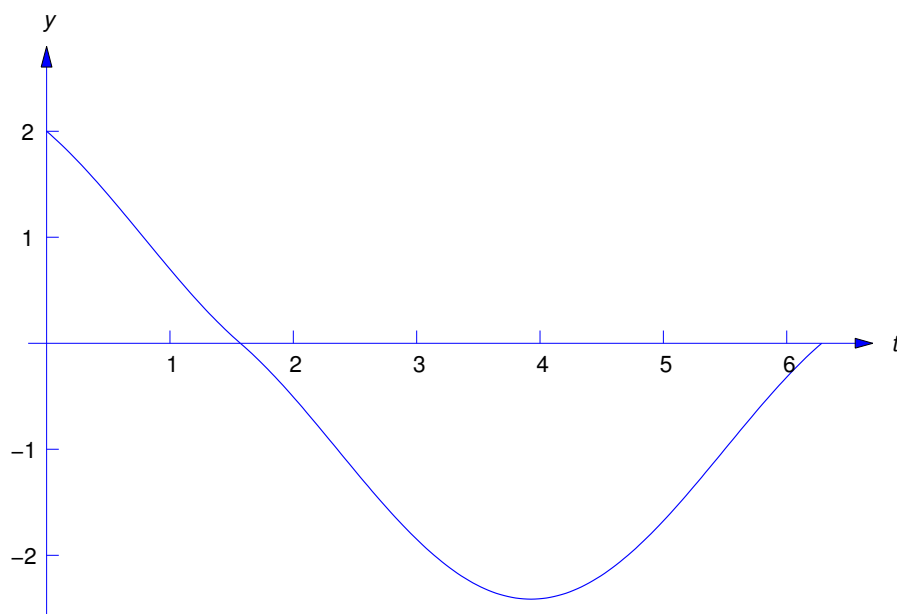

Figure 8.5.1 Graph of (8.5.4)

**Solution** The initial value problem in Step 1 is

$$y'' + y = 1, \quad y(0) = 2, \quad y'(0) = -1.$$

We leave it to you to verify that its solution is

$$y_0 = 1 + \cos t - \sin t.$$

Doing Step 2 yields  $y_0(\pi/2) = 0$  and  $y'_0(\pi/2) = -1$ , so the second initial value problem is

$$y'' + y = -1, \quad y\left(\frac{\pi}{2}\right) = 0, \quad y'\left(\frac{\pi}{2}\right) = -1.$$

We leave it to you to verify that the solution of this problem is

$$y_1 = -1 + \cos t + \sin t.$$

Hence, the solution of (8.5.3) is

$$y = \begin{cases} 1 + \cos t - \sin t, & 0 \leq t < \frac{\pi}{2}, \\ -1 + \cos t + \sin t, & t \geq \frac{\pi}{2} \end{cases} \quad (8.5.4)$$

(Figure:8.5.1).

If  $f_0$  and  $f_1$  are defined on  $[0, \infty)$ , we can rewrite (8.5.2) as

$$ay'' + by' + cy = f_0(t) + u(t - t_1)(f_1(t) - f_0(t)), \quad y(0) = k_0, \quad y'(0) = k_1,$$

and apply the method of Laplace transforms. We'll now solve the problem considered in Example 8.5.1 by this method.

**Example 8.5.2** Use the Laplace transform to solve the initial value problem

$$y'' + y = f(t), \quad y(0) = 2, \quad y'(0) = -1, \quad (8.5.5)$$

where

$$f(t) = \begin{cases} 1, & 0 \leq t < \frac{\pi}{2}, \\ -1, & t \geq \frac{\pi}{2}. \end{cases}$$

**Solution** Here

$$f(t) = 1 - 2u\left(t - \frac{\pi}{2}\right),$$

so Theorem 8.4.1 (with  $g(t) = 1$ ) implies that

$$\mathcal{L}(f) = \frac{1 - 2e^{-\pi s/2}}{s}.$$

Therefore, transforming (8.5.5) yields

$$(s^2 + 1)Y(s) = \frac{1 - 2e^{-\pi s/2}}{s} - 1 + 2s,$$

so

$$Y(s) = (1 - 2e^{-\pi s/2})G(s) + \frac{2s - 1}{s^2 + 1}, \quad (8.5.6)$$

with

$$G(s) = \frac{1}{s(s^2 + 1)}.$$

The form for the partial fraction expansion of  $G$  is

$$\frac{1}{s(s^2 + 1)} = \frac{A}{s} + \frac{Bs + C}{s^2 + 1}. \quad (8.5.7)$$

Multiplying through by  $s(s^2 + 1)$  yields

$$A(s^2 + 1) + (Bs + C)s = 1,$$

or

$$(A + B)s^2 + Cs + A = 1.$$

Equating coefficients of like powers of  $s$  on the two sides of this equation shows that  $A = 1$ ,  $B = -A = -1$  and  $C = 0$ . Hence, from (8.5.7),

$$G(s) = \frac{1}{s} - \frac{s}{s^2 + 1}.$$

Therefore

$$g(t) = 1 - \cos t.$$

From this, (8.5.6), and Theorem 8.4.2,

$$y = 1 - \cos t - 2u\left(t - \frac{\pi}{2}\right)\left(1 - \cos\left(t - \frac{\pi}{2}\right)\right) + 2 \cos t - \sin t.$$

Simplifying this (recalling that  $\cos(t - \pi/2) = \sin t$ ) yields

$$y = 1 + \cos t - \sin t - 2u\left(t - \frac{\pi}{2}\right)(1 - \sin t),$$



or

$$y = \begin{cases} 1 + \cos t - \sin t, & 0 \leq t < \frac{\pi}{2}, \\ -1 + \cos t + \sin t, & t \geq \frac{\pi}{2}, \end{cases}$$

which is the result obtained in Example 8.5.1.

**REMARK:** It isn't obvious that using the Laplace transform to solve (8.5.2) as we did in Example 8.5.2 yields a function  $y$  with the properties stated in Theorem 8.5.1; that is, such that  $y$  and  $y'$  are continuous on  $[0, \infty)$  and  $y''$  has limits from the right and left at  $t_1$ . However, this is true if  $f_0$  and  $f_1$  are continuous and of exponential order on  $[0, \infty)$ . A proof is sketched in Exercises 8.6.11–8.6.13.

**Example 8.5.3** Solve the initial value problem

$$y'' - y = f(t), \quad y(0) = -1, \quad y'(0) = 2, \quad (8.5.8)$$

where

$$f(t) = \begin{cases} t, & 0 \leq t < 1, \\ 1, & t \geq 1. \end{cases}$$

**Solution** Here

$$f(t) = t - u(t-1)(t-1),$$

so

$$\begin{aligned} \mathcal{L}(f) &= \mathcal{L}(t) - \mathcal{L}(u(t-1)(t-1)) \\ &= \mathcal{L}(t) - e^{-s}\mathcal{L}(t) \quad (\text{from Theorem 8.4.1}) \\ &= \frac{1}{s^2} - \frac{e^{-s}}{s^2}. \end{aligned}$$

Since transforming (8.5.8) yields

$$(s^2 - 1)Y(s) = \mathcal{L}(f) + 2 - s,$$

we see that

$$Y(s) = (1 - e^{-s})H(s) + \frac{2-s}{s^2-1}, \quad (8.5.9)$$

where

$$H(s) = \frac{1}{s^2(s^2-1)} = \frac{1}{s^2-1} - \frac{1}{s^2};$$

therefore

$$h(t) = \sinh t - t. \quad (8.5.10)$$

Since

$$\mathcal{L}^{-1}\left(\frac{2-s}{s^2-1}\right) = 2 \sinh t - \cosh t,$$

we conclude from (8.5.9), (8.5.10), and Theorem 8.4.1 that

$$y = \sinh t - t - u(t-1)(\sinh(t-1) - t + 1) + 2 \sinh t - \cosh t,$$

or

$$y = 3 \sinh t - \cosh t - t - u(t-1)(\sinh(t-1) - t + 1) \quad (8.5.11)$$

We leave it to you to verify that  $y$  and  $y'$  are continuous and  $y''$  has limits from the right and left at  $t_1 = 1$ .

**Example 8.5.4** Solve the initial value problem

$$y'' + y = f(t), \quad y(0) = 0, \quad y'(0) = 0, \quad (8.5.12)$$

where

$$f(t) = \begin{cases} 0, & 0 \leq t < \frac{\pi}{4}, \\ \cos 2t, & \frac{\pi}{4} \leq t < \pi, \\ 0, & t \geq \pi. \end{cases}$$

**Solution** Here

$$f(t) = u(t - \pi/4) \cos 2t - u(t - \pi) \cos 2t,$$

so

$$\begin{aligned} \mathcal{L}(f) &= \mathcal{L}(u(t - \pi/4) \cos 2t) - \mathcal{L}(u(t - \pi) \cos 2t) \\ &= e^{-\pi s/4} \mathcal{L}(\cos 2(t + \pi/4)) - e^{-\pi s} \mathcal{L}(\cos 2(t + \pi)) \\ &= -e^{-\pi s/4} \mathcal{L}(\sin 2t) - e^{-\pi s} \mathcal{L}(\cos 2t) \\ &= -\frac{2e^{-\pi s/4}}{s^2 + 4} - \frac{se^{-\pi s}}{s^2 + 4}. \end{aligned}$$

Since transforming (8.5.12) yields

$$(s^2 + 1)Y(s) = \mathcal{L}(f),$$

we see that

$$Y(s) = e^{-\pi s/4} H_1(s) + e^{-\pi s} H_2(s), \quad (8.5.13)$$

where

$$H_1(s) = -\frac{2}{(s^2 + 1)(s^2 + 4)} \quad \text{and} \quad H_2(s) = -\frac{s}{(s^2 + 1)(s^2 + 4)}. \quad (8.5.14)$$

To simplify the required partial fraction expansions, we first write

$$\frac{1}{(x+1)(x+4)} = \frac{1}{3} \left[ \frac{1}{x+1} - \frac{1}{x+4} \right].$$

Setting  $x = s^2$  and substituting the result in (8.5.14) yields

$$H_1(s) = -\frac{2}{3} \left[ \frac{1}{s^2 + 1} - \frac{1}{s^2 + 4} \right] \quad \text{and} \quad H_2(s) = -\frac{1}{3} \left[ \frac{s}{s^2 + 1} - \frac{s}{s^2 + 4} \right].$$

The inverse transforms are

$$h_1(t) = -\frac{2}{3} \sin t + \frac{1}{3} \sin 2t \quad \text{and} \quad h_2(t) = -\frac{1}{3} \cos t + \frac{1}{3} \cos 2t.$$

From (8.5.13) and Theorem 8.4.2,

$$y = u\left(t - \frac{\pi}{4}\right) h_1\left(t - \frac{\pi}{4}\right) + u(t - \pi) h_2(t - \pi). \quad (8.5.15)$$

Since

$$\begin{aligned} h_1\left(t - \frac{\pi}{4}\right) &= -\frac{2}{3} \sin\left(t - \frac{\pi}{4}\right) + \frac{1}{3} \sin 2\left(t - \frac{\pi}{4}\right) \\ &= -\frac{\sqrt{2}}{3} (\sin t - \cos t) - \frac{1}{3} \cos 2t \end{aligned}$$

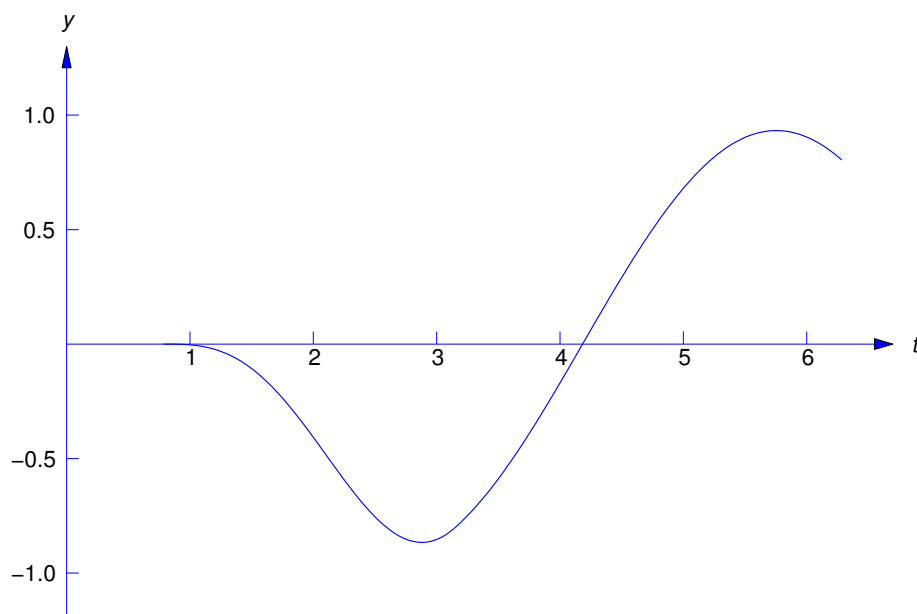

Figure 8.5.2 Graph of (8.5.16)

and

$$\begin{aligned} h_2(t - \pi) &= -\frac{1}{3} \cos(t - \pi) + \frac{1}{3} \cos 2(t - \pi) \\ &= \frac{1}{3} \cos t + \frac{1}{3} \cos 2t, \end{aligned}$$

(8.5.15) can be rewritten as

$$y = -\frac{1}{3}u\left(t - \frac{\pi}{4}\right) \left(\sqrt{2}(\sin t - \cos t) + \cos 2t\right) + \frac{1}{3}u(t - \pi)(\cos t + \cos 2t)$$

or

$$y = \begin{cases} 0, & 0 \leq t < \frac{\pi}{4}, \\ -\frac{\sqrt{2}}{3}(\sin t - \cos t) - \frac{1}{3} \cos 2t, & \frac{\pi}{4} \leq t < \pi, \\ -\frac{\sqrt{2}}{3} \sin t + \frac{1 + \sqrt{2}}{3} \cos t, & t \geq \pi. \end{cases} \quad (8.5.16)$$

We leave it to you to verify that  $y$  and  $y'$  are continuous and  $y''$  has limits from the right and left at  $t_1 = \pi/4$  and  $t_2 = \pi$  (Figure 8.5.2).

## 8.5 Exercises

In Exercises 1–20 use the Laplace transform to solve the initial value problem. Where indicated by C/G, graph the solution.

1.  $y'' + y = \begin{cases} 3, & 0 \leq t < \pi, \\ 0, & t \geq \pi, \end{cases} \quad y(0) = 0, \quad y'(0) = 0$
2.  $y'' + y = \begin{cases} 3, & 0 \leq t < 4, \\ 2t - 5, & t \geq 4, \end{cases} \quad y(0) = 1, \quad y'(0) = 0$
3.  $y'' - 2y' = \begin{cases} 4, & 0 \leq t < 1, \\ 6, & t \geq 1, \end{cases} \quad y(0) = -6, \quad y'(0) = 1$
4.  $y'' - y = \begin{cases} e^{2t}, & 0 \leq t < 2, \\ 1, & t \geq 2, \end{cases} \quad y(0) = 3, \quad y'(0) = -1$
5.  $y'' - 3y' + 2y = \begin{cases} 0, & 0 \leq t < 1, \\ 1, & 1 \leq t < 2, \\ -1, & t \geq 2, \end{cases} \quad y(0) = -3, \quad y'(0) = 1$
6. C/G  $y'' + 4y = \begin{cases} |\sin t|, & 0 \leq t < 2\pi, \\ 0, & t \geq 2\pi, \end{cases} \quad y(0) = -3, \quad y'(0) = 1$
7.  $y'' - 5y' + 4y = \begin{cases} 1, & 0 \leq t < 1 \\ -1, & 1 \leq t < 2, \\ 0, & t \geq 2, \end{cases} \quad y(0) = 3, \quad y'(0) = -5$
8.  $y'' + 9y = \begin{cases} \cos t, & 0 \leq t < \frac{3\pi}{2}, \\ \sin t, & t \geq \frac{3\pi}{2}, \end{cases} \quad y(0) = 0, \quad y'(0) = 0$
9. C/G  $y'' + 4y = \begin{cases} t, & 0 \leq t < \frac{\pi}{2}, \\ \pi, & t \geq \frac{\pi}{2}, \end{cases} \quad y(0) = 0, \quad y'(0) = 0$
10.  $y'' + y = \begin{cases} t, & 0 \leq t < \pi, \\ -t, & t \geq \pi, \end{cases} \quad y(0) = 0, \quad y'(0) = 0$
11.  $y'' - 3y' + 2y = \begin{cases} 0, & 0 \leq t < 2, \\ 2t - 4, & t \geq 2, \end{cases} \quad y(0) = 0, \quad y'(0) = 0$
12.  $y'' + y = \begin{cases} t, & 0 \leq t < 2\pi, \\ -2t, & t \geq 2\pi, \end{cases} \quad y(0) = 1, \quad y'(0) = 2$
13. C/G  $y'' + 3y' + 2y = \begin{cases} 1, & 0 \leq t < 2, \\ -1, & t \geq 2, \end{cases} \quad y(0) = 0, \quad y'(0) = 0$
14.  $y'' - 4y' + 3y = \begin{cases} -1, & 0 \leq t < 1, \\ 1, & t \geq 1, \end{cases} \quad y(0) = 0, \quad y'(0) = 0$
15.  $y'' + 2y' + y = \begin{cases} e^t, & 0 \leq t < 1, \\ e^t - 1, & t \geq 1, \end{cases} \quad y(0) = 3, \quad y'(0) = -1$
16.  $y'' + 2y' + y = \begin{cases} 4e^t, & 0 \leq t < 1, \\ 0, & t \geq 1, \end{cases} \quad y(0) = 0, \quad y'(0) = 0$
17.  $y'' + 3y' + 2y = \begin{cases} e^{-t}, & 0 \leq t < 1, \\ 0, & t \geq 1, \end{cases} \quad y(0) = 1, \quad y'(0) = -1$

$$18. \quad y'' - 4y' + 4y = \begin{cases} e^{2t}, & 0 \leq t < 2, \\ -e^{2t}, & t \geq 2, \end{cases} \quad y(0) = 0, \quad y'(0) = -1$$

$$19. \quad \boxed{\text{C/G}} \quad y'' = \begin{cases} t^2, & 0 \leq t < 1, \\ -t, & 1 \leq t < 2, \\ t + 1, & t \geq 2, \end{cases} \quad y(0) = 1, \quad y'(0) = 0$$

$$20. \quad y'' + 2y' + 2y = \begin{cases} 1, & 0 \leq t < 2\pi, \\ t, & 2\pi \leq t < 3\pi, \\ -1, & t \geq 3\pi, \end{cases} \quad y(0) = 2, \quad y'(0) = -1$$

21. Solve the initial value problem

$$y'' = f(t), \quad y(0) = 0, \quad y'(0) = 0,$$

where

$$f(t) = m + 1, \quad m \leq t < m + 1, \quad m = 0, 1, 2, \dots$$

22. Solve the given initial value problem and find a formula that does not involve step functions and represents  $y$  on each interval of continuity of  $f$ .

(a)  $y'' + y = f(t), \quad y(0) = 0, \quad y'(0) = 0;$   
 $f(t) = m + 1, \quad m\pi \leq t < (m + 1)\pi, \quad m = 0, 1, 2, \dots$

(b)  $y'' + y = f(t), \quad y(0) = 0, \quad y'(0) = 0;$   
 $f(t) = (m + 1)t, \quad 2m\pi \leq t < 2(m + 1)\pi, \quad m = 0, 1, 2, \dots$  HINT: You'll need the formula

$$1 + 2 + \dots + m = \frac{m(m + 1)}{2}.$$

(c)  $y'' + y = f(t), \quad y(0) = 0, \quad y'(0) = 0;$   
 $f(t) = (-1)^m, \quad m\pi \leq t < (m + 1)\pi, \quad m = 0, 1, 2, \dots$

(d)  $y'' - y = f(t), \quad y(0) = 0, \quad y'(0) = 0;$   
 $f(t) = m + 1, \quad m \leq t < (m + 1), \quad m = 0, 1, 2, \dots$

HINT: You will need the formula

$$1 + r + \dots + r^m = \frac{1 - r^{m+1}}{1 - r} \quad (r \neq 1).$$

(e)  $y'' + 2y' + 2y = f(t), \quad y(0) = 0, \quad y'(0) = 0;$   
 $f(t) = (m + 1)(\sin t + 2 \cos t), \quad 2m\pi \leq t < 2(m + 1)\pi, \quad m = 0, 1, 2, \dots$   
 (See the hint in (d).)

(f)  $y'' - 3y' + 2y = f(t), \quad y(0) = 0, \quad y'(0) = 0;$   
 $f(t) = m + 1, \quad m \leq t < m + 1, \quad m = 0, 1, 2, \dots$   
 (See the hints in (b) and (d).)

23. (a) Let  $g$  be continuous on  $(\alpha, \beta)$  and differentiable on the  $(\alpha, t_0)$  and  $(t_0, \beta)$ . Suppose  $A = \lim_{t \rightarrow t_0^-} g'(t)$  and  $B = \lim_{t \rightarrow t_0^+} g'(t)$  both exist. Use the mean value theorem to show that

$$\lim_{t \rightarrow t_0^-} \frac{g(t) - g(t_0)}{t - t_0} = A \quad \text{and} \quad \lim_{t \rightarrow t_0^+} \frac{g(t) - g(t_0)}{t - t_0} = B.$$

(b) Conclude from (a) that  $g'(t_0)$  exists and  $g'$  is continuous at  $t_0$  if  $A = B$ .

- (c) Conclude from (a) that if  $g$  is differentiable on  $(\alpha, \beta)$  then  $g'$  can't have a jump discontinuity on  $(\alpha, \beta)$ .
24. (a) Let  $a, b$ , and  $c$  be constants, with  $a \neq 0$ . Let  $f$  be piecewise continuous on an interval  $(\alpha, \beta)$ , with a single jump discontinuity at a point  $t_0$  in  $(\alpha, \beta)$ . Suppose  $y$  and  $y'$  are continuous on  $(\alpha, \beta)$  and  $y''$  on  $(\alpha, t_0)$  and  $(t_0, \beta)$ . Suppose also that

$$ay'' + by' + cy = f(t) \quad (\text{A})$$

on  $(\alpha, t_0)$  and  $(t_0, \beta)$ . Show that

$$y''(t_0+) - y''(t_0-) = \frac{f(t_0+) - f(t_0-)}{a} \neq 0.$$

- (b) Use (a) and Exercise 23(c) to show that (A) does not have solutions on any interval  $(\alpha, \beta)$  that contains a jump discontinuity of  $f$ .
25. Suppose  $P_0, P_1$ , and  $P_2$  are continuous and  $P_0$  has no zeros on an open interval  $(a, b)$ , and that  $F$  has a jump discontinuity at a point  $t_0$  in  $(a, b)$ . Show that the differential equation

$$P_0(t)y'' + P_1(t)y' + P_2(t)y = F(t)$$

has no solutions on  $(a, b)$ . HINT: Generalize the result of Exercise 24 and use Exercise 23(c).

26. Let  $0 = t_0 < t_1 < \cdots < t_n$ . Suppose  $f_m$  is continuous on  $[t_m, \infty)$  for  $m = 1, \dots, n$ . Let

$$f(t) = \begin{cases} f_m(t), & t_m \leq t < t_{m+1}, \quad m = 1, \dots, n-1, \\ f_n(t), & t \geq t_n. \end{cases}$$

Show that the solution of

$$ay'' + by' + cy = f(t), \quad y(0) = k_0, \quad y'(0) = k_1,$$

as defined following Theorem 8.5.1, is given by

$$y = \begin{cases} z_0(t), & 0 \leq t < t_1, \\ z_0(t) + z_1(t), & t_1 \leq t < t_2, \\ \vdots & \\ z_0 + \cdots + z_{n-1}(t), & t_{n-1} \leq t < t_n, \\ z_0 + \cdots + z_n(t), & t \geq t_n, \end{cases}$$

where  $z_0$  is the solution of

$$az'' + bz' + cz = f_0(t), \quad z(0) = k_0, \quad z'(0) = k_1$$

and  $z_m$  is the solution of

$$az'' + bz' + cz = f_m(t) - f_{m-1}(t), \quad z(t_m) = 0, \quad z'(t_m) = 0$$

for  $m = 1, \dots, n$ .

## 8.6 CONVOLUTION

In this section we consider the problem of finding the inverse Laplace transform of a product  $H(s) = F(s)G(s)$ , where  $F$  and  $G$  are the Laplace transforms of known functions  $f$  and  $g$ . To motivate our interest in this problem, consider the initial value problem

$$ay'' + by' + cy = f(t), \quad y(0) = 0, \quad y'(0) = 0.$$

Taking Laplace transforms yields

$$(as^2 + bs + c)Y(s) = F(s),$$

so

$$Y(s) = F(s)G(s), \tag{8.6.1}$$

where

$$G(s) = \frac{1}{as^2 + bs + c}.$$

Until now we've been interested in the factorization indicated in (8.6.1), since we dealt only with differential equations with specific forcing functions. Hence, we could simply do the indicated multiplication in (8.6.1) and use the table of Laplace transforms to find  $y = \mathcal{L}^{-1}(Y)$ . However, this isn't possible if we want a *formula* for  $y$  in terms of  $f$ , which may be unspecified.

To motivate the formula for  $\mathcal{L}^{-1}(FG)$ , consider the initial value problem

$$y' - ay = f(t), \quad y(0) = 0, \tag{8.6.2}$$

which we first solve without using the Laplace transform. The solution of the differential equation in (8.6.2) is of the form  $y = ue^{at}$  where

$$u' = e^{-at}f(t).$$

Integrating this from 0 to  $t$  and imposing the initial condition  $u(0) = y(0) = 0$  yields

$$u = \int_0^t e^{-a\tau} f(\tau) d\tau.$$

Therefore

$$y(t) = e^{at} \int_0^t e^{-a\tau} f(\tau) d\tau = \int_0^t e^{a(t-\tau)} f(\tau) d\tau. \tag{8.6.3}$$

Now we'll use the Laplace transform to solve (8.6.2) and compare the result to (8.6.3). Taking Laplace transforms in (8.6.2) yields

$$(s - a)Y(s) = F(s),$$

so

$$Y(s) = F(s) \frac{1}{s - a},$$

which implies that

$$y(t) = \mathcal{L}^{-1} \left( F(s) \frac{1}{s - a} \right). \tag{8.6.4}$$

If we now let  $g(t) = e^{at}$ , so that

$$G(s) = \frac{1}{s - a},$$

then (8.6.3) and (8.6.4) can be written as

$$y(t) = \int_0^t f(\tau)g(t - \tau) d\tau$$

and

$$y = \mathcal{L}^{-1}(FG),$$

respectively. Therefore

$$\mathcal{L}^{-1}(FG) = \int_0^t f(\tau)g(t-\tau) d\tau \quad (8.6.5)$$

in this case.

This motivates the next definition.

**Definition 8.6.1** The *convolution*  $f * g$  of two functions  $f$  and  $g$  is defined by

$$(f * g)(t) = \int_0^t f(\tau)g(t-\tau) d\tau.$$

It can be shown (Exercise 6) that  $f * g = g * f$ ; that is,

$$\int_0^t f(t-\tau)g(\tau) d\tau = \int_0^t f(\tau)g(t-\tau) d\tau.$$

Eqn. (8.6.5) shows that  $\mathcal{L}^{-1}(FG) = f * g$  in the special case where  $g(t) = e^{at}$ . This next theorem states that this is true in general.

**Theorem 8.6.2** [The Convolution Theorem] If  $\mathcal{L}(f) = F$  and  $\mathcal{L}(g) = G$ , then

$$\mathcal{L}(f * g) = FG.$$

A complete proof of the convolution theorem is beyond the scope of this book. However, we'll assume that  $f * g$  has a Laplace transform and verify the conclusion of the theorem in a purely computational way. By the definition of the Laplace transform,

$$\mathcal{L}(f * g) = \int_0^\infty e^{-st}(f * g)(t) dt = \int_0^\infty e^{-st} \int_0^t f(\tau)g(t-\tau) d\tau dt.$$

This iterated integral equals a double integral over the region shown in Figure 8.6.1. Reversing the order of integration yields

$$\mathcal{L}(f * g) = \int_0^\infty f(\tau) \int_\tau^\infty e^{-st}g(t-\tau) dt d\tau. \quad (8.6.6)$$

However, the substitution  $x = t - \tau$  shows that

$$\begin{aligned} \int_\tau^\infty e^{-st}g(t-\tau) dt &= \int_0^\infty e^{-s(x+\tau)}g(x) dx \\ &= e^{-s\tau} \int_0^\infty e^{-sx}g(x) dx = e^{-s\tau}G(s). \end{aligned}$$

Substituting this into (8.6.6) and noting that  $G(s)$  is independent of  $\tau$  yields

$$\begin{aligned} \mathcal{L}(f * g) &= \int_0^\infty e^{-s\tau}f(\tau)G(s) d\tau \\ &= G(s) \int_0^\infty e^{-s\tau}f(\tau) d\tau = F(s)G(s). \end{aligned}$$



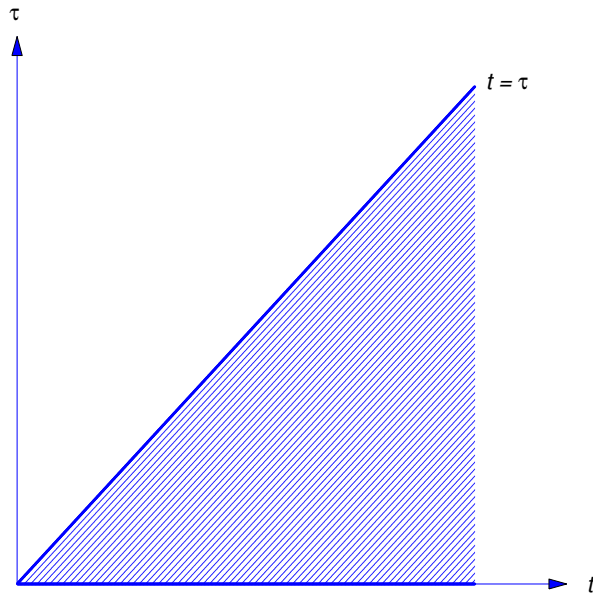

Figure 8.6.1

**Example 8.6.1** Let

$$f(t) = e^{at} \quad \text{and} \quad g(t) = e^{bt} \quad (a \neq b).$$

Verify that  $\mathcal{L}(f * g) = \mathcal{L}(f)\mathcal{L}(g)$ , as implied by the convolution theorem.

**Solution** We first compute

$$\begin{aligned} (f * g)(t) &= \int_0^t e^{a\tau} e^{b(t-\tau)} d\tau = e^{bt} \int_0^t e^{(a-b)\tau} d\tau \\ &= e^{bt} \left. \frac{e^{(a-b)\tau}}{a-b} \right|_0^t = \frac{e^{bt} [e^{(a-b)t} - 1]}{a-b} \\ &= \frac{e^{at} - e^{bt}}{a-b}. \end{aligned}$$

Since

$$e^{at} \leftrightarrow \frac{1}{s-a} \quad \text{and} \quad e^{bt} \leftrightarrow \frac{1}{s-b},$$

it follows that

$$\begin{aligned} \mathcal{L}(f * g) &= \frac{1}{a-b} \left[ \frac{1}{s-a} - \frac{1}{s-b} \right] \\ &= \frac{1}{(s-a)(s-b)} \\ &= \mathcal{L}(e^{at})\mathcal{L}(e^{bt}) = \mathcal{L}(f)\mathcal{L}(g). \end{aligned}$$

**A Formula for the Solution of an Initial Value Problem**

The convolution theorem provides a formula for the solution of an initial value problem for a linear constant coefficient second order equation with an unspecified. The next three examples illustrate this.

**Example 8.6.2** Find a formula for the solution of the initial value problem

$$y'' - 2y' + y = f(t), \quad y(0) = k_0, \quad y'(0) = k_1. \quad (8.6.7)$$

**Solution** Taking Laplace transforms in (8.6.7) yields

$$(s^2 - 2s + 1)Y(s) = F(s) + (k_1 + k_0s) - 2k_0.$$

Therefore

$$\begin{aligned} Y(s) &= \frac{1}{(s-1)^2} F(s) + \frac{k_1 + k_0s - 2k_0}{(s-1)^2} \\ &= \frac{1}{(s-1)^2} F(s) + \frac{k_0}{s-1} + \frac{k_1 - k_0}{(s-1)^2}. \end{aligned}$$

From the table of Laplace transforms,

$$\mathcal{L}^{-1} \left( \frac{k_0}{s-1} + \frac{k_1 - k_0}{(s-1)^2} \right) = e^t (k_0 + (k_1 - k_0)t).$$

Since

$$\frac{1}{(s-1)^2} \leftrightarrow te^t \quad \text{and} \quad F(s) \leftrightarrow f(t),$$

the convolution theorem implies that

$$\mathcal{L}^{-1} \left( \frac{1}{(s-1)^2} F(s) \right) = \int_0^t \tau e^\tau f(t-\tau) d\tau.$$

Therefore the solution of (8.6.7) is

$$y(t) = e^t (k_0 + (k_1 - k_0)t) + \int_0^t \tau e^\tau f(t-\tau) d\tau.$$

**Example 8.6.3** Find a formula for the solution of the initial value problem

$$y'' + 4y = f(t), \quad y(0) = k_0, \quad y'(0) = k_1. \quad (8.6.8)$$

**Solution** Taking Laplace transforms in (8.6.8) yields

$$(s^2 + 4)Y(s) = F(s) + k_1 + k_0s.$$

Therefore

$$Y(s) = \frac{1}{(s^2 + 4)} F(s) + \frac{k_1 + k_0s}{s^2 + 4}.$$

From the table of Laplace transforms,

$$\mathcal{L}^{-1} \left( \frac{k_1 + k_0s}{s^2 + 4} \right) = k_0 \cos 2t + \frac{k_1}{2} \sin 2t.$$

Since

$$\frac{1}{(s^2 + 4)} \leftrightarrow \frac{1}{2} \sin 2t \quad \text{and} \quad F(s) \leftrightarrow f(t),$$

the convolution theorem implies that

$$\mathcal{L}^{-1} \left( \frac{1}{(s^2 + 4)} F(s) \right) = \frac{1}{2} \int_0^t f(t - \tau) \sin 2\tau \, d\tau.$$

Therefore the solution of (8.6.8) is

$$y(t) = k_0 \cos 2t + \frac{k_1}{2} \sin 2t + \frac{1}{2} \int_0^t f(t - \tau) \sin 2\tau \, d\tau.$$

**Example 8.6.4** Find a formula for the solution of the initial value problem

$$y'' + 2y' + 2y = f(t), \quad y(0) = k_0, \quad y'(0) = k_1. \quad (8.6.9)$$

**Solution** Taking Laplace transforms in (8.6.9) yields

$$(s^2 + 2s + 2)Y(s) = F(s) + k_1 + k_0s + 2k_0.$$

Therefore

$$\begin{aligned} Y(s) &= \frac{1}{(s+1)^2 + 1} F(s) + \frac{k_1 + k_0s + 2k_0}{(s+1)^2 + 1} \\ &= \frac{1}{(s+1)^2 + 1} F(s) + \frac{(k_1 + k_0) + k_0(s+1)}{(s+1)^2 + 1}. \end{aligned}$$

From the table of Laplace transforms,

$$\mathcal{L}^{-1} \left( \frac{(k_1 + k_0) + k_0(s+1)}{(s+1)^2 + 1} \right) = e^{-t} ((k_1 + k_0) \sin t + k_0 \cos t).$$

Since

$$\frac{1}{(s+1)^2 + 1} \leftrightarrow e^{-t} \sin t \quad \text{and} \quad F(s) \leftrightarrow f(t),$$

the convolution theorem implies that

$$\mathcal{L}^{-1} \left( \frac{1}{(s+1)^2 + 1} F(s) \right) = \int_0^t f(t - \tau) e^{-\tau} \sin \tau \, d\tau.$$

Therefore the solution of (8.6.9) is

$$y(t) = e^{-t} ((k_1 + k_0) \sin t + k_0 \cos t) + \int_0^t f(t - \tau) e^{-\tau} \sin \tau \, d\tau. \quad (8.6.10)$$

### Evaluating Convolution Integrals

We'll say that an integral of the form  $\int_0^t u(\tau)v(t - \tau) \, d\tau$  is a *convolution integral*. The convolution theorem provides a convenient way to evaluate convolution integrals.

**Example 8.6.5** Evaluate the convolution integral

$$h(t) = \int_0^t (t - \tau)^5 \tau^7 d\tau.$$

**Solution** We could evaluate this integral by expanding  $(t - \tau)^5$  in powers of  $\tau$  and then integrating. However, the convolution theorem provides an easier way. The integral is the convolution of  $f(t) = t^5$  and  $g(t) = t^7$ . Since

$$t^5 \leftrightarrow \frac{5!}{s^6} \quad \text{and} \quad t^7 \leftrightarrow \frac{7!}{s^8},$$

the convolution theorem implies that

$$h(t) \leftrightarrow \frac{5!7!}{s^{14}} = \frac{5!7!}{13!} \frac{13!}{s^{14}},$$

where we have written the second equality because

$$\frac{13!}{s^{14}} \leftrightarrow t^{13}.$$

Hence,

$$h(t) = \frac{5!7!}{13!} t^{13}.$$

**Example 8.6.6** Use the convolution theorem and a partial fraction expansion to evaluate the convolution integral

$$h(t) = \int_0^t \sin a(t - \tau) \cos b\tau d\tau \quad (|a| \neq |b|).$$

**Solution** Since

$$\sin at \leftrightarrow \frac{a}{s^2 + a^2} \quad \text{and} \quad \cos bt \leftrightarrow \frac{s}{s^2 + b^2},$$

the convolution theorem implies that

$$H(s) = \frac{a}{s^2 + a^2} \frac{s}{s^2 + b^2}.$$

Expanding this in a partial fraction expansion yields

$$H(s) = \frac{a}{b^2 - a^2} \left[ \frac{s}{s^2 + a^2} - \frac{s}{s^2 + b^2} \right].$$

Therefore

$$h(t) = \frac{a}{b^2 - a^2} (\cos at - \cos bt).$$

### Volterra Integral Equations

An equation of the form

$$y(t) = f(t) + \int_0^t k(t - \tau)y(\tau) d\tau \tag{8.6.11}$$

is a *Volterra integral equation*. Here  $f$  and  $k$  are given functions and  $y$  is unknown. Since the integral on the right is a convolution integral, the convolution theorem provides a convenient formula for solving (8.6.11). Taking Laplace transforms in (8.6.11) yields

$$Y(s) = F(s) + K(s)Y(s),$$

and solving this for  $Y(s)$  yields

$$Y(s) = \frac{F(s)}{1 - K(s)}.$$

We then obtain the solution of (8.6.11) as  $y = \mathcal{L}^{-1}(Y)$ .

**Example 8.6.7** Solve the integral equation

$$y(t) = 1 + 2 \int_0^t e^{-2(t-\tau)} y(\tau) d\tau. \quad (8.6.12)$$

**Solution** Taking Laplace transforms in (8.6.12) yields

$$Y(s) = \frac{1}{s} + \frac{2}{s+2} Y(s),$$

and solving this for  $Y(s)$  yields

$$Y(s) = \frac{1}{s} + \frac{2}{s^2}.$$

Hence,

$$y(t) = 1 + 2t.$$

### Transfer Functions

The next theorem presents a formula for the solution of the general initial value problem

$$ay'' + by' + cy = f(t), \quad y(0) = k_0, \quad y'(0) = k_1,$$

where we assume for simplicity that  $f$  is continuous on  $[0, \infty)$  and that  $\mathcal{L}(f)$  exists. In Exercises 11–14 it's shown that the formula is valid under much weaker conditions on  $f$ .

**Theorem 8.6.3** *Suppose  $f$  is continuous on  $[0, \infty)$  and has a Laplace transform. Then the solution of the initial value problem*

$$ay'' + by' + cy = f(t), \quad y(0) = k_0, \quad y'(0) = k_1, \quad (8.6.13)$$

is

$$y(t) = k_0 y_1(t) + k_1 y_2(t) + \int_0^t w(\tau) f(t - \tau) d\tau, \quad (8.6.14)$$

where  $y_1$  and  $y_2$  satisfy

$$ay_1'' + by_1' + cy_1 = 0, \quad y_1(0) = 1, \quad y_1'(0) = 0, \quad (8.6.15)$$

and

$$ay_2'' + by_2' + cy_2 = 0, \quad y_2(0) = 0, \quad y_2'(0) = 1, \quad (8.6.16)$$

and

$$w(t) = \frac{1}{a} y_2(t). \quad (8.6.17)$$

**Proof** Taking Laplace transforms in (8.6.13) yields

$$p(s)Y(s) = F(s) + a(k_1 + k_0s) + bk_0,$$

where

$$p(s) = as^2 + bs + c.$$

Hence,

$$Y(s) = W(s)F(s) + V(s) \quad (8.6.18)$$

with

$$W(s) = \frac{1}{p(s)} \quad (8.6.19)$$

and

$$V(s) = \frac{a(k_1 + k_0s) + bk_0}{p(s)}. \quad (8.6.20)$$

Taking Laplace transforms in (8.6.15) and (8.6.16) shows that

$$p(s)Y_1(s) = as + b \quad \text{and} \quad p(s)Y_2(s) = a.$$

Therefore

$$Y_1(s) = \frac{as + b}{p(s)}$$

and

$$Y_2(s) = \frac{a}{p(s)}. \quad (8.6.21)$$

Hence, (8.6.20) can be rewritten as

$$V(s) = k_0Y_1(s) + k_1Y_2(s).$$

Substituting this into (8.6.18) yields

$$Y(s) = k_0Y_1(s) + k_1Y_2(s) + \frac{1}{a}Y_2(s)F(s).$$

Taking inverse transforms and invoking the convolution theorem yields (8.6.14). Finally, (8.6.19) and (8.6.21) imply (8.6.17). ■

It is useful to note from (8.6.14) that  $y$  is of the form

$$y = v + h,$$

where

$$v(t) = k_0y_1(t) + k_1y_2(t)$$

depends on the initial conditions and is independent of the forcing function, while

$$h(t) = \int_0^t w(\tau)f(t-\tau) d\tau$$

depends on the forcing function and is independent of the initial conditions. If the zeros of the characteristic polynomial

$$p(s) = as^2 + bs + c$$

of the complementary equation have negative real parts, then  $y_1$  and  $y_2$  both approach zero as  $t \rightarrow \infty$ , so  $\lim_{t \rightarrow \infty} v(t) = 0$  for any choice of initial conditions. Moreover, the value of  $h(t)$  is essentially

independent of the values of  $f(t - \tau)$  for large  $\tau$ , since  $\lim_{\tau \rightarrow \infty} w(\tau) = 0$ . In this case we say that  $v$  and  $h$  are *transient* and *steady state components*, respectively, of the solution  $y$  of (8.6.13). These definitions apply to the initial value problem of Example 8.6.4, where the zeros of

$$p(s) = s^2 + 2s + 2 = (s + 1)^2 + 1$$

are  $-1 \pm i$ . From (8.6.10), we see that the solution of the general initial value problem of Example 8.6.4 is  $y = v + h$ , where

$$v(t) = e^{-t} ((k_1 + k_0) \sin t + k_0 \cos t)$$

is the transient component of the solution and

$$h(t) = \int_0^t f(t - \tau) e^{-\tau} \sin \tau \, d\tau$$

is the steady state component. The definitions don't apply to the initial value problems considered in Examples 8.6.2 and 8.6.3, since the zeros of the characteristic polynomials in these two examples don't have negative real parts.

In physical applications where the input  $f$  and the output  $y$  of a device are related by (8.6.13), the zeros of the characteristic polynomial usually do have negative real parts. Then  $W = \mathcal{L}(w)$  is called the *transfer function* of the device. Since

$$H(s) = W(s)F(s),$$

we see that

$$W(s) = \frac{H(s)}{F(s)}$$

is the ratio of the transform of the steady state output to the transform of the input.

Because of the form of

$$h(t) = \int_0^t w(\tau) f(t - \tau) \, d\tau,$$

$w$  is sometimes called the *weighting function* of the device, since it assigns weights to past values of the input  $f$ . It is also called the *impulse response* of the device, for reasons discussed in the next section.

Formula (8.6.14) is given in more detail in Exercises 8–10 for the three possible cases where the zeros of  $p(s)$  are real and distinct, real and repeated, or complex conjugates, respectively.

## 8.6 Exercises

---

1. Express the inverse transform as an integral.

(a)  $\frac{1}{s^2(s^2 + 4)}$

(b)  $\frac{s}{(s + 2)(s^2 + 9)}$

(c)  $\frac{s}{(s^2 + 4)(s^2 + 9)}$

(d)  $\frac{s}{(s^2 + 1)^2}$

(e)  $\frac{1}{s(s - a)}$

(f)  $\frac{1}{(s + 1)(s^2 + 2s + 2)}$

(g)  $\frac{1}{(s + 1)^2(s^2 + 4s + 5)}$

(h)  $\frac{1}{(s - 1)^3(s + 2)^2}$

(i)  $\frac{s-1}{s^2(s^2-2s+2)}$

(k)  $\frac{1}{(s-3)^5 s^6}$

(m)  $\frac{1}{s^2(s-2)^3}$

(j)  $\frac{s(s+3)}{(s^2+4)(s^2+6s+10)}$

(l)  $\frac{1}{(s-1)^3(s^2+4)}$

(n)  $\frac{1}{s^7(s-2)^6}$

2. Find the Laplace transform.

(a)  $\int_0^t \sin a\tau \cos b(t-\tau) d\tau$

(c)  $\int_0^t \sinh a\tau \cosh a(t-\tau) d\tau$

(e)  $e^t \int_0^t \sin \omega\tau \cos \omega(t-\tau) d\tau$

(g)  $e^{-t} \int_0^t e^{-\tau} \tau \cos \omega(t-\tau) d\tau$

(i)  $\int_0^t \tau e^{2\tau} \sin 2(t-\tau) d\tau$

(k)  $\int_0^t \tau^6 e^{-(t-\tau)} \sin 3(t-\tau) d\tau$

(m)  $\int_0^t (t-\tau)^7 e^{-\tau} \sin 2\tau d\tau$

(b)  $\int_0^t e^\tau \sin a(t-\tau) d\tau$

(d)  $\int_0^t \tau(t-\tau) \sin \omega\tau \cos \omega(t-\tau) d\tau$

(f)  $e^t \int_0^t \tau^2(t-\tau)e^\tau d\tau$

(h)  $e^t \int_0^t e^{2\tau} \sinh(t-\tau) d\tau$

(j)  $\int_0^t (t-\tau)^3 e^\tau d\tau$

(l)  $\int_0^t \tau^2(t-\tau)^3 d\tau$

(n)  $\int_0^t (t-\tau)^4 \sin 2\tau d\tau$

3. Find a formula for the solution of the initial value problem.

(a)  $y'' + 3y' + y = f(t), \quad y(0) = 0, \quad y'(0) = 0$

(b)  $y'' + 4y = f(t), \quad y(0) = 0, \quad y'(0) = 0$

(c)  $y'' + 2y' + y = f(t), \quad y(0) = 0, \quad y'(0) = 0$

(d)  $y'' + k^2 y = f(t), \quad y(0) = 1, \quad y'(0) = -1$

(e)  $y'' + 6y' + 9y = f(t), \quad y(0) = 0, \quad y'(0) = -2$

(f)  $y'' - 4y = f(t), \quad y(0) = 0, \quad y'(0) = 3$

(g)  $y'' - 5y' + 6y = f(t), \quad y(0) = 1, \quad y'(0) = 3$

(h)  $y'' + \omega^2 y = f(t), \quad y(0) = k_0, \quad y'(0) = k_1$

4. Solve the integral equation.

(a)  $y(t) = t - \int_0^t (t-\tau)y(\tau) d\tau$

(b)  $y(t) = \sin t - 2 \int_0^t \cos(t-\tau)y(\tau) d\tau$

(c)  $y(t) = 1 + 2 \int_0^t y(\tau) \cos(t-\tau) d\tau$  (d)  $y(t) = t + \int_0^t y(\tau)e^{-(t-\tau)} d\tau$

(e)  $y'(t) = t + \int_0^t y(\tau) \cos(t-\tau) d\tau, \quad y(0) = 4$



$$(f) y(t) = \cos t - \sin t + \int_0^t y(\tau) \sin(t - \tau) d\tau$$

5. Use the convolution theorem to evaluate the integral.

$$(a) \int_0^t (t - \tau)^7 \tau^8 d\tau$$

$$(b) \int_0^t (t - \tau)^{13} \tau^7 d\tau$$

$$(c) \int_0^t (t - \tau)^6 \tau^7 d\tau$$

$$(d) \int_0^t e^{-\tau} \sin(t - \tau) d\tau$$

$$(e) \int_0^t \sin \tau \cos 2(t - \tau) d\tau$$

6. Show that

$$\int_0^t f(t - \tau)g(\tau) d\tau = \int_0^t f(\tau)g(t - \tau) d\tau$$

by introducing the new variable of integration  $x = t - \tau$  in the first integral.

7. Use the convolution theorem to show that if  $f(t) \leftrightarrow F(s)$  then

$$\int_0^t f(\tau) d\tau \leftrightarrow \frac{F(s)}{s}.$$

8. Show that if  $p(s) = as^2 + bs + c$  has distinct real zeros  $r_1$  and  $r_2$  then the solution of

$$ay'' + by' + cy = f(t), \quad y(0) = k_0, \quad y'(0) = k_1$$

is

$$y(t) = k_0 \frac{r_2 e^{r_1 t} - r_1 e^{r_2 t}}{r_2 - r_1} + k_1 \frac{e^{r_2 t} - e^{r_1 t}}{r_2 - r_1} + \frac{1}{a(r_2 - r_1)} \int_0^t (e^{r_2 \tau} - e^{r_1 \tau}) f(t - \tau) d\tau.$$

9. Show that if  $p(s) = as^2 + bs + c$  has a repeated real zero  $r_1$  then the solution of

$$ay'' + by' + cy = f(t), \quad y(0) = k_0, \quad y'(0) = k_1$$

is

$$y(t) = k_0(1 - r_1 t)e^{r_1 t} + k_1 t e^{r_1 t} + \frac{1}{a} \int_0^t \tau e^{r_1 \tau} f(t - \tau) d\tau.$$

10. Show that if  $p(s) = as^2 + bs + c$  has complex conjugate zeros  $\lambda \pm i\omega$  then the solution of

$$ay'' + by' + cy = f(t), \quad y(0) = k_0, \quad y'(0) = k_1$$

is

$$y(t) = e^{\lambda t} \left[ k_0 \left( \cos \omega t - \frac{\lambda}{\omega} \sin \omega t \right) + \frac{k_1}{\omega} \sin \omega t \right] + \frac{1}{a\omega} \int_0^t e^{\lambda \tau} f(t - \tau) \sin \omega \tau d\tau.$$

11. Let

$$w = \mathcal{L}^{-1} \left( \frac{1}{as^2 + bs + c} \right),$$

where  $a, b$ , and  $c$  are constants and  $a \neq 0$ .

(a) Show that  $w$  is the solution of

$$aw'' + bw' + cw = 0, \quad w(0) = 0, \quad w'(0) = \frac{1}{a}.$$

(b) Let  $f$  be continuous on  $[0, \infty)$  and define

$$h(t) = \int_0^t w(t - \tau)f(\tau) d\tau.$$

Use *Leibniz's rule* for differentiating an integral with respect to a parameter to show that  $h$  is the solution of

$$ah'' + bh' + ch = f, \quad h(0) = 0, \quad h'(0) = 0.$$

(c) Show that the function  $y$  in Eqn. (8.6.14) is the solution of Eqn. (8.6.13) provided that  $f$  is continuous on  $[0, \infty)$ ; thus, it's not necessary to assume that  $f$  has a Laplace transform.

12. Consider the initial value problem

$$ay'' + by' + cy = f(t), \quad y(0) = 0, \quad y'(0) = 0, \quad (\text{A})$$

where  $a, b$ , and  $c$  are constants,  $a \neq 0$ , and

$$f(t) = \begin{cases} f_0(t), & 0 \leq t < t_1, \\ f_1(t), & t \geq t_1. \end{cases}$$

Assume that  $f_0$  is continuous and of exponential order on  $[0, \infty)$  and  $f_1$  is continuous and of exponential order on  $[t_1, \infty)$ . Let

$$p(s) = as^2 + bs + c.$$

(a) Show that the Laplace transform of the solution of (A) is

$$Y(s) = \frac{F_0(s) + e^{-st_1}G(s)}{p(s)}$$

where  $g(t) = f_1(t + t_1) - f_0(t + t_1)$ .

(b) Let  $w$  be as in Exercise 11. Use Theorem 8.4.2 and the convolution theorem to show that the solution of (A) is

$$y(t) = \int_0^t w(t - \tau)f_0(\tau) d\tau + u(t - t_1) \int_0^{t-t_1} w(t - t_1 - \tau)g(\tau) d\tau$$

for  $t > 0$ .

(c) Henceforth, assume only that  $f_0$  is continuous on  $[0, \infty)$  and  $f_1$  is continuous on  $[t_1, \infty)$ . Use Exercise 11 (a) and (b) to show that

$$y'(t) = \int_0^t w'(t - \tau)f_0(\tau) d\tau + u(t - t_1) \int_0^{t-t_1} w'(t - t_1 - \tau)g(\tau) d\tau$$

for  $t > 0$ , and

$$y''(t) = \frac{f(t)}{a} + \int_0^t w''(t-\tau)f_0(\tau) d\tau + u(t-t_1) \int_0^{t-t_1} w''(t-t_1-\tau)g(\tau) d\tau$$

for  $0 < t < t_1$  and  $t > t_1$ . Also, show  $y$  satisfies the differential equation in (A) on  $(0, t_1)$  and  $(t_1, \infty)$ .

(d) Show that  $y$  and  $y'$  are continuous on  $[0, \infty)$ .

13. Suppose

$$f(t) = \begin{cases} f_0(t), & 0 \leq t < t_1, \\ f_1(t), & t_1 \leq t < t_2, \\ \vdots \\ f_{k-1}(t), & t_{k-1} \leq t < t_k, \\ f_k(t), & t \geq t_k, \end{cases}$$

where  $f_m$  is continuous on  $[t_m, \infty)$  for  $m = 0, \dots, k$  (let  $t_0 = 0$ ), and define

$$g_m(t) = f_m(t+t_m) - f_{m-1}(t+t_m), \quad m = 1, \dots, k.$$

Extend the results of Exercise 12 to show that the solution of

$$ay'' + by' + cy = f(t), \quad y(0) = 0, \quad y'(0) = 0$$

is

$$y(t) = \int_0^t w(t-\tau)f_0(\tau) d\tau + \sum_{m=1}^k u(t-t_m) \int_0^{t-t_m} w(t-t_m-\tau)g_m(\tau) d\tau.$$

14. Let  $\{t_m\}_{m=0}^\infty$  be a sequence of points such that  $t_0 = 0$ ,  $t_{m+1} > t_m$ , and  $\lim_{m \rightarrow \infty} t_m = \infty$ . For each nonnegative integer  $m$  let  $f_m$  be continuous on  $[t_m, \infty)$ , and let  $f$  be defined on  $[0, \infty)$  by

$$f(t) = f_m(t), \quad t_m \leq t < t_{m+1} \quad m = 0, 1, 2, \dots$$

Let

$$g_m(t) = f_m(t+t_m) - f_{m-1}(t+t_m), \quad m = 1, \dots, k.$$

Extend the results of Exercise 13 to show that the solution of

$$ay'' + by' + cy = f(t), \quad y(0) = 0, \quad y'(0) = 0$$

is

$$y(t) = \int_0^t w(t-\tau)f_0(\tau) d\tau + \sum_{m=1}^\infty u(t-t_m) \int_0^{t-t_m} w(t-t_m-\tau)g_m(\tau) d\tau.$$

HINT: See Exercise 30.

### 8.7 CONSTANT COEFFICIENT EQUATIONS WITH IMPULSES

So far in this chapter, we've considered initial value problems for the constant coefficient equation

$$ay'' + by' + cy = f(t),$$

where  $f$  is continuous or piecewise continuous on  $[0, \infty)$ . In this section we consider initial value problems where  $f$  represents a force that's very large for a short time and zero otherwise. We say that such forces are *impulsive*. Impulsive forces occur, for example, when two objects collide. Since it isn't feasible to represent such forces as continuous or piecewise continuous functions, we must construct a different mathematical model to deal with them.

If  $f$  is an integrable function and  $f(t) = 0$  for  $t$  outside of the interval  $[t_0, t_0 + h]$ , then  $\int_{t_0}^{t_0+h} f(t) dt$  is called the *total impulse* of  $f$ . We're interested in the idealized situation where  $h$  is so small that the total impulse can be assumed to be applied instantaneously at  $t = t_0$ . We say in this case that  $f$  is an *impulse function*. In particular, we denote by  $\delta(t - t_0)$  the impulse function with total impulse equal to one, applied at  $t = t_0$ . (The impulse function  $\delta(t)$  obtained by setting  $t_0 = 0$  is the *Dirac  $\delta$  function*.) It must be understood, however, that  $\delta(t - t_0)$  isn't a function in the standard sense, since our "definition" implies that  $\delta(t - t_0) = 0$  if  $t \neq t_0$ , while

$$\int_{t_0}^{t_0} \delta(t - t_0) dt = 1.$$

From calculus we know that no function can have these properties; nevertheless, there's a branch of mathematics known as the *theory of distributions* where the definition can be made rigorous. Since the theory of distributions is beyond the scope of this book, we'll take an intuitive approach to impulse functions.

Our first task is to define what we mean by the solution of the initial value problem

$$ay'' + by' + cy = \delta(t - t_0), \quad y(0) = 0, \quad y'(0) = 0,$$

where  $t_0$  is a fixed nonnegative number. The next theorem will motivate our definition.

**Theorem 8.7.1** *Suppose  $t_0 \geq 0$ . For each positive number  $h$ , let  $y_h$  be the solution of the initial value problem*

$$ay_h'' + by_h' + cy_h = f_h(t), \quad y_h(0) = 0, \quad y_h'(0) = 0, \quad (8.7.1)$$

where

$$f_h(t) = \begin{cases} 0, & 0 \leq t < t_0, \\ 1/h, & t_0 \leq t < t_0 + h, \\ 0, & t \geq t_0 + h, \end{cases} \quad (8.7.2)$$

so  $f_h$  has unit total impulse equal to the area of the shaded rectangle in Figure 8.7.1. Then

$$\lim_{h \rightarrow 0^+} y_h(t) = u(t - t_0)w(t - t_0), \quad (8.7.3)$$

where

$$w = \mathcal{L}^{-1} \left( \frac{1}{as^2 + bs + c} \right).$$

**Proof** Taking Laplace transforms in (8.7.1) yields

$$(as^2 + bs + c)Y_h(s) = F_h(s),$$

so

$$Y_h(s) = \frac{F_h(s)}{as^2 + bs + c}.$$

The convolution theorem implies that

$$y_h(t) = \int_0^t w(t - \tau)f_h(\tau) d\tau.$$

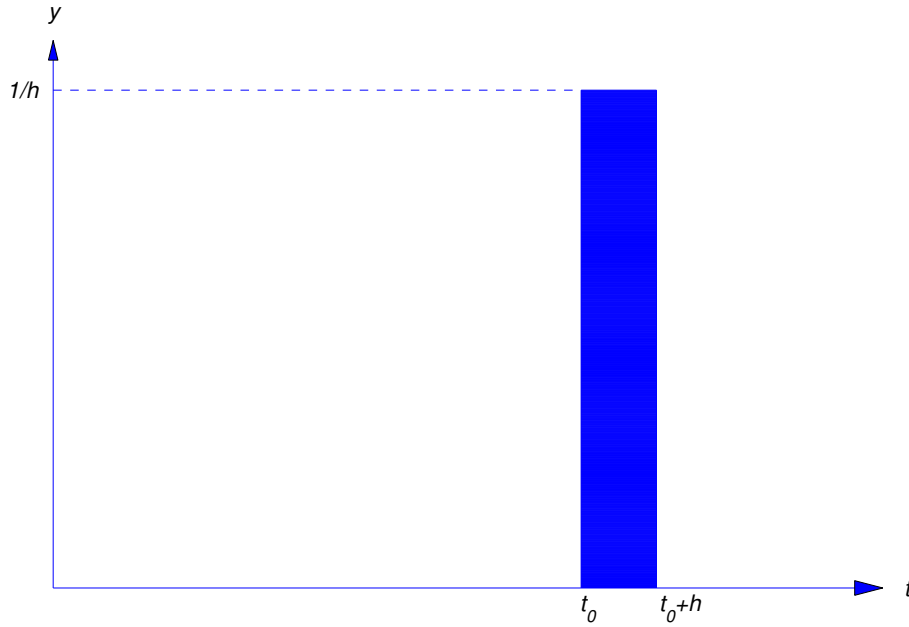

Figure 8.7.1  $y = f_h(t)$

Therefore, (8.7.2) implies that

$$y_h(t) = \begin{cases} 0, & 0 \leq t < t_0, \\ \frac{1}{h} \int_{t_0}^t w(t - \tau) d\tau, & t_0 \leq t \leq t_0 + h, \\ \frac{1}{h} \int_{t_0}^{t_0+h} w(t - \tau) d\tau, & t > t_0 + h. \end{cases} \quad (8.7.4)$$

Since  $y_h(t) = 0$  for all  $h$  if  $0 \leq t \leq t_0$ , it follows that

$$\lim_{h \rightarrow 0^+} y_h(t) = 0 \quad \text{if} \quad 0 \leq t \leq t_0. \quad (8.7.5)$$

We'll now show that

$$\lim_{h \rightarrow 0^+} y_h(t) = w(t - t_0) \quad \text{if} \quad t > t_0. \quad (8.7.6)$$

Suppose  $t$  is fixed and  $t > t_0$ . From (8.7.4),

$$y_h(t) = \frac{1}{h} \int_{t_0}^{t_0+h} w(t - \tau) d\tau \quad \text{if} \quad h < t - t_0. \quad (8.7.7)$$

Since

$$\frac{1}{h} \int_{t_0}^{t_0+h} d\tau = 1, \quad (8.7.8)$$

we can write

$$w(t - t_0) = \frac{1}{h} w(t - t_0) \int_{t_0}^{t_0+h} d\tau = \frac{1}{h} \int_{t_0}^{t_0+h} w(t - t_0) d\tau.$$

From this and (8.7.7),

$$y_h(t) - w(t - t_0) = \frac{1}{h} \int_{t_0}^{t_0+h} (w(t - \tau) - w(t - t_0)) d\tau.$$

Therefore

$$|y_h(t) - w(t - t_0)| \leq \frac{1}{h} \int_{t_0}^{t_0+h} |w(t - \tau) - w(t - t_0)| d\tau. \quad (8.7.9)$$

Now let  $M_h$  be the maximum value of  $|w(t - \tau) - w(t - t_0)|$  as  $\tau$  varies over the interval  $[t_0, t_0 + h]$ . (Remember that  $t$  and  $t_0$  are fixed.) Then (8.7.8) and (8.7.9) imply that

$$|y_h(t) - w(t - t_0)| \leq \frac{1}{h} M_h \int_{t_0}^{t_0+h} d\tau = M_h. \quad (8.7.10)$$

But  $\lim_{h \rightarrow 0^+} M_h = 0$ , since  $w$  is continuous. Therefore (8.7.10) implies (8.7.6). This and (8.7.5) imply (8.7.3). ■

Theorem 8.7.1 motivates the next definition.

**Definition 8.7.2** If  $t_0 > 0$ , then the solution of the initial value problem

$$ay'' + by' + cy = \delta(t - t_0), \quad y(0) = 0, \quad y'(0) = 0, \quad (8.7.11)$$

is defined to be

$$y = u(t - t_0)w(t - t_0),$$

where

$$w = \mathcal{L}^{-1} \left( \frac{1}{as^2 + bs + c} \right).$$

In physical applications where the input  $f$  and the output  $y$  of a device are related by the differential equation

$$ay'' + by' + cy = f(t),$$

$w$  is called the *impulse response* of the device. Note that  $w$  is the solution of the initial value problem

$$aw'' + bw' + cw = 0, \quad w(0) = 0, \quad w'(0) = 1/a, \quad (8.7.12)$$

as can be seen by using the Laplace transform to solve this problem. (Verify.) On the other hand, we can solve (8.7.12) by the methods of Section 5.2 and show that  $w$  is defined on  $(-\infty, \infty)$  by

$$w = \frac{e^{r_2 t} - e^{r_1 t}}{a(r_2 - r_1)}, \quad w = \frac{1}{a} t e^{r_1 t}, \quad \text{or} \quad w = \frac{1}{a\omega} e^{\lambda t} \sin \omega t, \quad (8.7.13)$$

depending upon whether the polynomial  $p(r) = ar^2 + br + c$  has distinct real zeros  $r_1$  and  $r_2$ , a repeated zero  $r_1$ , or complex conjugate zeros  $\lambda \pm i\omega$ . (In most physical applications, the zeros of the characteristic polynomial have negative real parts, so  $\lim_{t \rightarrow \infty} w(t) = 0$ .) This means that  $y = u(t - t_0)w(t - t_0)$  is defined on  $(-\infty, \infty)$  and has the following properties:

$$y(t) = 0, \quad t < t_0,$$

$$ay'' + by' + cy = 0 \quad \text{on} \quad (-\infty, t_0) \quad \text{and} \quad (t_0, \infty),$$

and

$$y'_-(t_0) = 0, \quad y'_+(t_0) = 1/a \quad (8.7.14)$$

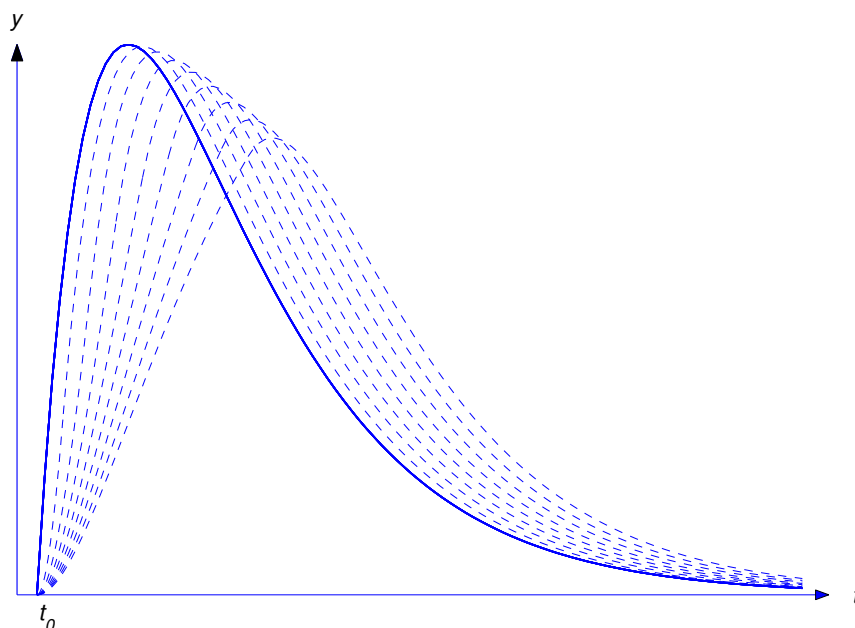

Figure 8.7.2 An illustration of Theorem 8.7.1

(remember that  $y'_-(t_0)$  and  $y'_+(t_0)$  are derivatives from the right and left, respectively) and  $y'(t_0)$  does not exist. Thus, even though we defined  $y = u(t-t_0)w(t-t_0)$  to be the solution of (8.7.11), this function *doesn't satisfy* the differential equation in (8.7.11) at  $t_0$ , since it isn't differentiable there; in fact (8.7.14) indicates that an impulse causes a jump discontinuity in velocity. (To see that this is reasonable, think of what happens when you hit a ball with a bat.) This means that the initial value problem (8.7.11) doesn't make sense if  $t_0 = 0$ , since  $y'(0)$  doesn't exist in this case. However  $y = u(t)w(t)$  can be defined to be the solution of the modified initial value problem

$$ay'' + by' + cy = \delta(t), \quad y(0) = 0, \quad y'_-(0) = 0,$$

where the condition on the derivative at  $t = 0$  has been replaced by a condition on the derivative from the left.

Figure 8.7.2 illustrates Theorem 8.7.1 for the case where the impulse response  $w$  is the first expression in (8.7.13) and  $r_1$  and  $r_2$  are distinct and both negative. The solid curve in the figure is the graph of  $w$ . The dashed curves are solutions of (8.7.1) for various values of  $h$ . As  $h$  decreases the graph of  $y_h$  moves to the left toward the graph of  $w$ .

**Example 8.7.1** Find the solution of the initial value problem

$$y'' - 2y' + y = \delta(t - t_0), \quad y(0) = 0, \quad y'(0) = 0, \quad (8.7.15)$$

where  $t_0 > 0$ . Then interpret the solution for the case where  $t_0 = 0$ .

**Solution** Here

$$w = \mathcal{L}^{-1} \left( \frac{1}{s^2 - 2s + 1} \right) = \mathcal{L}^{-1} \left( \frac{1}{(s-1)^2} \right) = te^{-t},$$

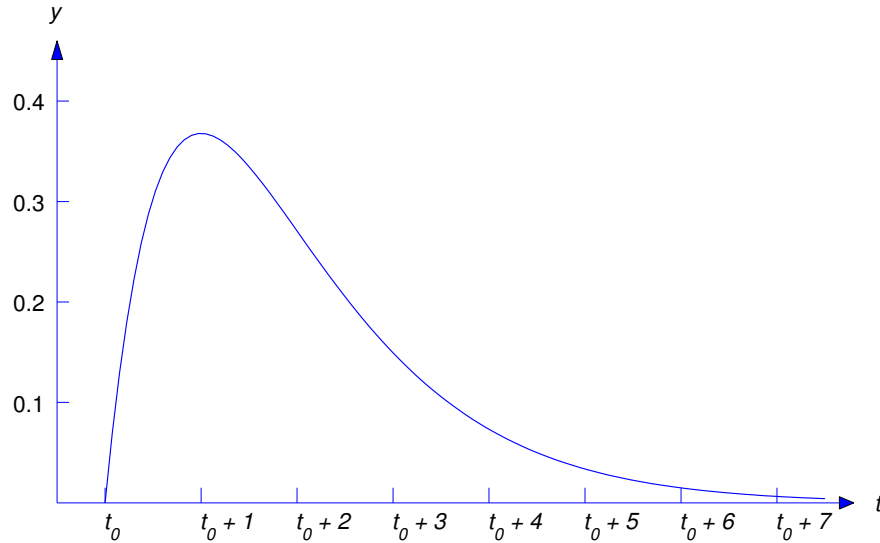

Figure 8.7.3  $y = u(t - t_0)(t - t_0)e^{-(t-t_0)}$

so Definition 8.7.2 yields

$$y = u(t - t_0)(t - t_0)e^{-(t-t_0)}$$

as the solution of (8.7.15) if  $t_0 > 0$ . If  $t_0 = 0$ , then (8.7.15) doesn't have a solution; however,  $y = u(t)te^{-t}$  (which we would usually write simply as  $y = te^{-t}$ ) is the solution of the modified initial value problem

$$y'' - 2y' + y = \delta(t), \quad y(0) = 0, \quad y'_-(0) = 0.$$

The graph of  $y = u(t - t_0)(t - t_0)e^{-(t-t_0)}$  is shown in Figure 8.7.3

Definition 8.7.2 and the principle of superposition motivate the next definition. ■

**Definition 8.7.3** Suppose  $\alpha$  is a nonzero constant and  $f$  is piecewise continuous on  $[0, \infty)$ . If  $t_0 > 0$ , then the solution of the initial value problem

$$ay'' + by' + cy = f(t) + \alpha\delta(t - t_0), \quad y(0) = k_0, \quad y'(0) = k_1$$

is defined to be

$$y(t) = \hat{y}(t) + \alpha u(t - t_0)w(t - t_0),$$

where  $\hat{y}$  is the solution of

$$ay'' + by' + cy = f(t), \quad y(0) = k_0, \quad y'(0) = k_1.$$

This definition also applies if  $t_0 = 0$ , provided that the initial condition  $y'(0) = k_1$  is replaced by  $y'_-(0) = k_1$ .

**Example 8.7.2** Solve the initial value problem

$$y'' + 6y' + 5y = 3e^{-2t} + 2\delta(t - 1), \quad y(0) = -3, \quad y'(0) = 2. \quad (8.7.16)$$



**Solution** We leave it to you to show that the solution of

$$y'' + 6y' + 5y = 3e^{-2t}, \quad y(0) = -3, \quad y'(0) = 2$$

is

$$\hat{y} = -e^{-2t} + \frac{1}{2}e^{-5t} - \frac{5}{2}e^{-t}.$$

Since

$$\begin{aligned} w(t) &= \mathcal{L}^{-1}\left(\frac{1}{s^2 + 6s + 5}\right) = \mathcal{L}^{-1}\left(\frac{1}{(s+1)(s+5)}\right) \\ &= \frac{1}{4}\mathcal{L}^{-1}\left(\frac{1}{s+1} - \frac{1}{s+5}\right) = \frac{e^{-t} - e^{-5t}}{4}, \end{aligned}$$

the solution of (8.7.16) is

$$y = -e^{-2t} + \frac{1}{2}e^{-5t} - \frac{5}{2}e^{-t} + u(t-1)\frac{e^{-(t-1)} - e^{-5(t-1)}}{2} \quad (8.7.17)$$

(Figure 8.7.4) ■

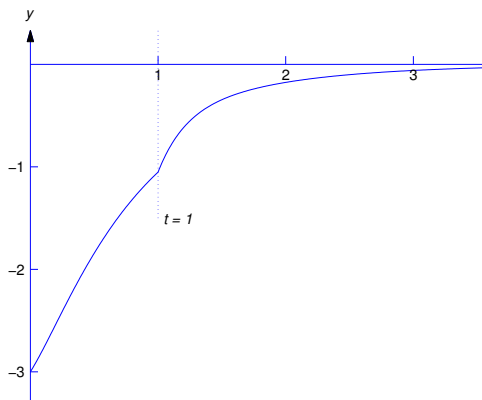

Figure 8.7.4 Graph of (8.7.17)

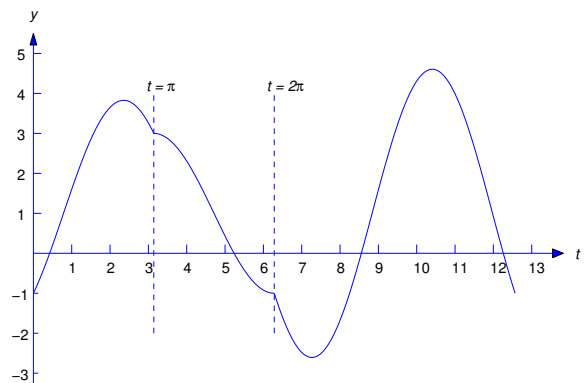

Figure 8.7.5 Graph of (8.7.19)

Definition 8.7.3 can be extended in the obvious way to cover the case where the forcing function contains more than one impulse.

**Example 8.7.3** Solve the initial value problem

$$y'' + y = 1 + 2\delta(t - \pi) - 3\delta(t - 2\pi), \quad y(0) = -1, \quad y'(0) = 2. \quad (8.7.18)$$

**Solution** We leave it to you to show that

$$\hat{y} = 1 - 2 \cos t + 2 \sin t$$

is the solution of

$$y'' + y = 1, \quad y(0) = -1, \quad y'(0) = 2.$$

Since

$$w = \mathcal{L}^{-1}\left(\frac{1}{s^2 + 1}\right) = \sin t,$$

the solution of (8.7.18) is

$$\begin{aligned}y &= 1 - 2 \cos t + 2 \sin t + 2u(t - \pi) \sin(t - \pi) - 3u(t - 2\pi) \sin(t - 2\pi) \\ &= 1 - 2 \cos t + 2 \sin t - 2u(t - \pi) \sin t - 3u(t - 2\pi) \sin t,\end{aligned}$$

or

$$y = \begin{cases} 1 - 2 \cos t + 2 \sin t, & 0 \leq t < \pi, \\ 1 - 2 \cos t, & \pi \leq t < 2\pi, \\ 1 - 2 \cos t - 3 \sin t, & t \geq 2\pi \end{cases} \quad (8.7.19)$$

(Figure 8.7.5).

## 8.7 Exercises

In Exercises 1–20 solve the initial value problem. Where indicated by  $\boxed{\text{C/G}}$ , graph the solution.

1.  $y'' + 3y' + 2y = 6e^{2t} + 2\delta(t - 1)$ ,  $y(0) = 2$ ,  $y'(0) = -6$
2.  $\boxed{\text{C/G}}$   $y'' + y' - 2y = -10e^{-t} + 5\delta(t - 1)$ ,  $y(0) = 7$ ,  $y'(0) = -9$
3.  $y'' - 4y = 2e^{-t} + 5\delta(t - 1)$ ,  $y(0) = -1$ ,  $y'(0) = 2$
4.  $\boxed{\text{C/G}}$   $y'' + y = \sin 3t + 2\delta(t - \pi/2)$ ,  $y(0) = 1$ ,  $y'(0) = -1$
5.  $y'' + 4y = 4 + \delta(t - 3\pi)$ ,  $y(0) = 0$ ,  $y'(0) = 1$
6.  $y'' - y = 8 + 2\delta(t - 2)$ ,  $y(0) = -1$ ,  $y'(0) = 1$
7.  $y'' + y' = e^t + 3\delta(t - 6)$ ,  $y(0) = -1$ ,  $y'(0) = 4$
8.  $y'' + 4y = 8e^{2t} + \delta(t - \pi/2)$ ,  $y(0) = 8$ ,  $y'(0) = 0$
9.  $\boxed{\text{C/G}}$   $y'' + 3y' + 2y = 1 + \delta(t - 1)$ ,  $y(0) = 1$ ,  $y'(0) = -1$
10.  $y'' + 2y' + y = e^t + 2\delta(t - 2)$ ,  $y(0) = -1$ ,  $y'(0) = 2$
11.  $\boxed{\text{C/G}}$   $y'' + 4y = \sin t + \delta(t - \pi/2)$ ,  $y(0) = 0$ ,  $y'(0) = 2$
12.  $y'' + 2y' + 2y = \delta(t - \pi) - 3\delta(t - 2\pi)$ ,  $y(0) = -1$ ,  $y'(0) = 2$
13.  $y'' + 4y' + 13y = \delta(t - \pi/6) + 2\delta(t - \pi/3)$ ,  $y(0) = 1$ ,  $y'(0) = 2$
14.  $2y'' - 3y' - 2y = 1 + \delta(t - 2)$ ,  $y(0) = -1$ ,  $y'(0) = 2$
15.  $4y'' - 4y' + 5y = 4\sin t - 4\cos t + \delta(t - \pi/2) - \delta(t - \pi)$ ,  $y(0) = 1$ ,  $y'(0) = 1$
16.  $y'' + y = \cos 2t + 2\delta(t - \pi/2) - 3\delta(t - \pi)$ ,  $y(0) = 0$ ,  $y'(0) = -1$
17.  $\boxed{\text{C/G}}$   $y'' - y = 4e^{-t} - 5\delta(t - 1) + 3\delta(t - 2)$ ,  $y(0) = 0$ ,  $y'(0) = 0$
18.  $y'' + 2y' + y = e^t - \delta(t - 1) + 2\delta(t - 2)$ ,  $y(0) = 0$ ,  $y'(0) = -1$
19.  $y'' + y = f(t) + \delta(t - 2\pi)$ ,  $y(0) = 0$ ,  $y'(0) = 1$ , and
 
$$f(t) = \begin{cases} \sin 2t, & 0 \leq t < \pi, \\ 0, & t \geq \pi. \end{cases}$$
20.  $y'' + 4y = f(t) + \delta(t - \pi) - 3\delta(t - 3\pi/2)$ ,  $y(0) = 1$ ,  $y'(0) = -1$ , and
 
$$f(t) = \begin{cases} 1, & 0 \leq t < \pi/2, \\ 2, & t \geq \pi/2 \end{cases}$$
21.  $y'' + y = \delta(t)$ ,  $y(0) = 1$ ,  $y'_-(0) = -2$
22.  $y'' - 4y = 3\delta(t)$ ,  $y(0) = -1$ ,  $y'_-(0) = 7$
23.  $y'' + 3y' + 2y = -5\delta(t)$ ,  $y(0) = 0$ ,  $y'_-(0) = 0$
24.  $y'' + 4y' + 4y = -\delta(t)$ ,  $y(0) = 1$ ,  $y'_-(0) = 5$
25.  $4y'' + 4y' + y = 3\delta(t)$ ,  $y(0) = 1$ ,  $y'_-(0) = -6$

In Exercises 26–28, solve the initial value problem

$$ay''_h + by'_h + cy_h = \begin{cases} 0, & 0 \leq t < t_0, \\ 1/h, & t_0 \leq t < t_0 + h, \\ 0, & t \geq t_0 + h, \end{cases} \quad y_h(0) = 0, \quad y'_h(0) = 0,$$

where  $t_0 > 0$  and  $h > 0$ . Then find

$$w = \mathcal{L}^{-1} \left( \frac{1}{as^2 + bs + c} \right)$$

and verify Theorem 8.7.1 by graphing  $w$  and  $y_h$  on the same axes, for small positive values of  $h$ .

26.  $\boxed{\text{L}}$   $y'' + 2y' + 2y = f_h(t), \quad y(0) = 0, \quad y'(0) = 0$

27.  $\boxed{\text{L}}$   $y'' + 2y' + y = f_h(t), \quad y(0) = 0, \quad y'(0) = 0$

28.  $\boxed{\text{L}}$   $y'' + 3y' + 2y = f_h(t), \quad y(0) = 0, \quad y'(0) = 0$

29. Recall from Section 6.2 that the displacement of an object of mass  $m$  in a spring–mass system in free damped oscillation is

$$my'' + cy' + ky = 0, \quad y(0) = y_0, \quad y'(0) = v_0,$$

and that  $y$  can be written as

$$y = Re^{-ct/2m} \cos(\omega_1 t - \phi)$$

if the motion is underdamped. Suppose  $y(\tau) = 0$ . Find the impulse that would have to be applied to the object at  $t = \tau$  to put it in equilibrium.

30. Solve the initial value problem. Find a formula that does not involve step functions and represents  $y$  on each subinterval of  $[0, \infty)$  on which the forcing function is zero.

(a)  $y'' - y = \sum_{k=1}^{\infty} \delta(t - k), \quad y(0) = 0, \quad y'(0) = 1$

(b)  $y'' + y = \sum_{k=1}^{\infty} \delta(t - 2k\pi), \quad y(0) = 0, \quad y'(0) = 1$

(c)  $y'' - 3y' + 2y = \sum_{k=1}^{\infty} \delta(t - k), \quad y(0) = 0, \quad y'(0) = 1$

(d)  $y'' + y = \sum_{k=1}^{\infty} \delta(t - k\pi), \quad y(0) = 0, \quad y'(0) = 0$

**8.8 A BRIEF TABLE OF LAPLACE TRANSFORMS**

$f(t)$	$F(s)$	
1	$\frac{1}{s}$	$(s > 0)$
$t^n$ ( $n = \text{integer} > 0$ )	$\frac{n!}{s^{n+1}}$	$(s > 0)$
$t^p, p > -1$	$\frac{\Gamma(p+1)}{s^{(p+1)}}$	$(s > 0)$
$e^{at}$	$\frac{1}{s-a}$	$(s > a)$
$t^n e^{at}$ ( $n = \text{integer} > 0$ )	$\frac{n!}{(s-a)^{n+1}}$	$(s > 0)$
$\cos \omega t$	$\frac{s}{s^2 + \omega^2}$	$(s > 0)$
$\sin \omega t$	$\frac{\omega}{s^2 + \omega^2}$	$(s > 0)$
$e^{\lambda t} \cos \omega t$	$\frac{s-\lambda}{(s-\lambda)^2 + \omega^2}$	$(s > \lambda)$
$e^{\lambda t} \sin \omega t$	$\frac{\omega}{(s-\lambda)^2 + \omega^2}$	$(s > \lambda)$
$\cosh bt$	$\frac{s}{s^2 - b^2}$	$(s >  b )$
$\sinh bt$	$\frac{b}{s^2 - b^2}$	$(s >  b )$
$t \cos \omega t$	$\frac{s^2 - \omega^2}{(s^2 + \omega^2)^2}$	$(s > 0)$

$t \sin \omega t$	$\frac{2\omega s}{(s^2 + \omega^2)^2}$	$(s > 0)$
$\sin \omega t - \omega t \cos \omega t$	$\frac{2\omega^3}{(s^2 + \omega^2)^2}$	$(s > 0)$
$\omega t - \sin \omega t$	$\frac{\omega^3}{s^2(s^2 + \omega^2)^2}$	$(s > 0)$
$\frac{1}{t} \sin \omega t$	$\arctan\left(\frac{\omega}{s}\right)$	$(s > 0)$
$e^{at} f(t)$	$F(s - a)$	
$t^k f(t)$	$(-1)^k F^{(k)}(s)$	
$f(\omega t)$	$\frac{1}{\omega} F\left(\frac{s}{\omega}\right), \quad \omega > 0$	
$u(t - \tau)$	$\frac{e^{-\tau s}}{s}$	$(s > 0)$
$u(t - \tau)f(t - \tau) (\tau > 0)$	$e^{-\tau s} F(s)$	
$\int_0^t f(\tau)g(t - \tau) d\tau$	$F(s) \cdot G(s)$	
$\delta(t - a)$	$e^{-as}$	$(s > 0)$

# CHAPTER 9

## Linear Higher Order Equations

IN THIS CHAPTER we extend the results obtained in Chapter 5 for linear second order equations to linear higher order equations.

SECTION 9.1 presents a theoretical introduction to linear higher order equations.

SECTION 9.2 discusses higher order constant coefficient homogeneous equations.

SECTION 9.3 presents the method of undetermined coefficients for higher order equations.

SECTION 9.4 extends the method of variation of parameters to higher order equations.

## 9.1 INTRODUCTION TO LINEAR HIGHER ORDER EQUATIONS

An  $n$ th order differential equation is said to be *linear* if it can be written in the form

$$y^{(n)} + p_1(x)y^{(n-1)} + \cdots + p_n(x)y = f(x). \quad (9.1.1)$$

We considered equations of this form with  $n = 1$  in Section 2.1 and with  $n = 2$  in Chapter 5. In this chapter  $n$  is an arbitrary positive integer.

In this section we sketch the general theory of linear  $n$ th order equations. Since this theory has already been discussed for  $n = 2$  in Sections 5.1 and 5.3, we'll omit proofs.

For convenience, we consider linear differential equations written as

$$P_0(x)y^{(n)} + P_1(x)y^{(n-1)} + \cdots + P_n(x)y = F(x), \quad (9.1.2)$$

which can be rewritten as (9.1.1) on any interval on which  $P_0$  has no zeros, with  $p_1 = P_1/P_0, \dots, p_n = P_n/P_0$  and  $f = F/P_0$ . For simplicity, throughout this chapter we'll abbreviate the left side of (9.1.2) by  $Ly$ ; that is,

$$Ly = P_0y^{(n)} + P_1y^{(n-1)} + \cdots + P_ny.$$

We say that the equation  $Ly = F$  is *normal* on  $(a, b)$  if  $P_0, P_1, \dots, P_n$  and  $F$  are continuous on  $(a, b)$  and  $P_0$  has no zeros on  $(a, b)$ . If this is so then  $Ly = F$  can be written as (9.1.1) with  $p_1, \dots, p_n$  and  $f$  continuous on  $(a, b)$ .

The next theorem is analogous to Theorem 5.3.1.

**Theorem 9.1.1** *Suppose  $Ly = F$  is normal on  $(a, b)$ , let  $x_0$  be a point in  $(a, b)$ , and let  $k_0, k_1, \dots, k_{n-1}$  be arbitrary real numbers. Then the initial value problem*

$$Ly = F, \quad y(x_0) = k_0, \quad y'(x_0) = k_1, \dots, \quad y^{(n-1)}(x_0) = k_{n-1}$$

*has a unique solution on  $(a, b)$ .*

### Homogeneous Equations

Eqn. (9.1.2) is said to be *homogeneous* if  $F \equiv 0$  and *nonhomogeneous* otherwise. Since  $y \equiv 0$  is obviously a solution of  $Ly = 0$ , we call it the *trivial* solution. Any other solution is *nontrivial*.

If  $y_1, y_2, \dots, y_n$  are defined on  $(a, b)$  and  $c_1, c_2, \dots, c_n$  are constants, then

$$y = c_1y_1 + c_2y_2 + \cdots + c_ny_n \quad (9.1.3)$$

is a *linear combination* of  $\{y_1, y_2, \dots, y_n\}$ . It's easy to show that if  $y_1, y_2, \dots, y_n$  are solutions of  $Ly = 0$  on  $(a, b)$ , then so is any linear combination of  $\{y_1, y_2, \dots, y_n\}$ . (See the proof of Theorem 5.1.2.) We say that  $\{y_1, y_2, \dots, y_n\}$  is a *fundamental set of solutions of  $Ly = 0$  on  $(a, b)$*  if every solution of  $Ly = 0$  on  $(a, b)$  can be written as a linear combination of  $\{y_1, y_2, \dots, y_n\}$ , as in (9.1.3). In this case we say that (9.1.3) is the *general solution of  $Ly = 0$  on  $(a, b)$* .

It can be shown (Exercises 14 and 15) that if the equation  $Ly = 0$  is normal on  $(a, b)$  then it has infinitely many fundamental sets of solutions on  $(a, b)$ . The next definition will help to identify fundamental sets of solutions of  $Ly = 0$ .

We say that  $\{y_1, y_2, \dots, y_n\}$  is *linearly independent* on  $(a, b)$  if the only constants  $c_1, c_2, \dots, c_n$  such that

$$c_1y_1(x) + c_2y_2(x) + \cdots + c_ny_n(x) = 0, \quad a < x < b, \quad (9.1.4)$$

are  $c_1 = c_2 = \cdots = c_n = 0$ . If (9.1.4) holds for some set of constants  $c_1, c_2, \dots, c_n$  that are not all zero, then  $\{y_1, y_2, \dots, y_n\}$  is *linearly dependent* on  $(a, b)$ .

The next theorem is analogous to Theorem 5.1.3.



**Theorem 9.1.2** *If  $Ly = 0$  is normal on  $(a, b)$ , then a set  $\{y_1, y_2, \dots, y_n\}$  of  $n$  solutions of  $Ly = 0$  on  $(a, b)$  is a fundamental set if and only if it's linearly independent on  $(a, b)$ .*

**Example 9.1.1** The equation

$$x^3 y''' - x^2 y'' - 2xy' + 6y = 0 \quad (9.1.5)$$

is normal and has the solutions  $y_1 = x^2$ ,  $y_2 = x^3$ , and  $y_3 = 1/x$  on  $(-\infty, 0)$  and  $(0, \infty)$ . Show that  $\{y_1, y_2, y_3\}$  is linearly independent on  $(-\infty, 0)$  and  $(0, \infty)$ . Then find the general solution of (9.1.5) on  $(-\infty, 0)$  and  $(0, \infty)$ .

**Solution** Suppose

$$c_1 x^2 + c_2 x^3 + \frac{c_3}{x} = 0 \quad (9.1.6)$$

on  $(0, \infty)$ . We must show that  $c_1 = c_2 = c_3 = 0$ . Differentiating (9.1.6) twice yields the system

$$\begin{aligned} c_1 x^2 + c_2 x^3 + \frac{c_3}{x} &= 0 \\ 2c_1 x + 3c_2 x^2 - \frac{c_3}{x^2} &= 0 \\ 2c_1 + 6c_2 x + \frac{2c_3}{x^3} &= 0. \end{aligned} \quad (9.1.7)$$

If (9.1.7) holds for all  $x$  in  $(0, \infty)$ , then it certainly holds at  $x = 1$ ; therefore,

$$\begin{aligned} c_1 + c_2 + c_3 &= 0 \\ 2c_1 + 3c_2 - c_3 &= 0 \\ 2c_1 + 6c_2 + 2c_3 &= 0. \end{aligned} \quad (9.1.8)$$

By solving this system directly, you can verify that it has only the trivial solution  $c_1 = c_2 = c_3 = 0$ ; however, for our purposes it's more useful to recall from linear algebra that a homogeneous linear system of  $n$  equations in  $n$  unknowns has only the trivial solution if its determinant is nonzero. Since the determinant of (9.1.8) is

$$\begin{vmatrix} 1 & 1 & 1 \\ 2 & 3 & -1 \\ 2 & 6 & 2 \end{vmatrix} = \begin{vmatrix} 1 & 0 & 0 \\ 2 & 1 & -3 \\ 2 & 4 & 0 \end{vmatrix} = 12,$$

it follows that (9.1.8) has only the trivial solution, so  $\{y_1, y_2, y_3\}$  is linearly independent on  $(0, \infty)$ . Now Theorem 9.1.2 implies that

$$y = c_1 x^2 + c_2 x^3 + \frac{c_3}{x}$$

is the general solution of (9.1.5) on  $(0, \infty)$ . To see that this is also true on  $(-\infty, 0)$ , assume that (9.1.6) holds on  $(-\infty, 0)$ . Setting  $x = -1$  in (9.1.7) yields

$$\begin{aligned} c_1 - c_2 - c_3 &= 0 \\ -2c_1 + 3c_2 - c_3 &= 0 \\ 2c_1 - 6c_2 - 2c_3 &= 0. \end{aligned}$$

Since the determinant of this system is

$$\begin{vmatrix} 1 & -1 & -1 \\ -2 & 3 & -1 \\ 2 & -6 & -2 \end{vmatrix} = \begin{vmatrix} 1 & 0 & 0 \\ -2 & 1 & -3 \\ 2 & -4 & 0 \end{vmatrix} = -12,$$

it follows that  $c_1 = c_2 = c_3 = 0$ ; that is,  $\{y_1, y_2, y_3\}$  is linearly independent on  $(-\infty, 0)$ .

**Example 9.1.2** The equation

$$y^{(4)} + y''' - 7y'' - y' + 6y = 0 \quad (9.1.9)$$

is normal and has the solutions  $y_1 = e^x$ ,  $y_2 = e^{-x}$ ,  $y_3 = e^{2x}$ , and  $y_4 = e^{-3x}$  on  $(-\infty, \infty)$ . (Verify.) Show that  $\{y_1, y_2, y_3, y_4\}$  is linearly independent on  $(-\infty, \infty)$ . Then find the general solution of (9.1.9).

**Solution** Suppose  $c_1, c_2, c_3$ , and  $c_4$  are constants such that

$$c_1e^x + c_2e^{-x} + c_3e^{2x} + c_4e^{-3x} = 0 \quad (9.1.10)$$

for all  $x$ . We must show that  $c_1 = c_2 = c_3 = c_4 = 0$ . Differentiating (9.1.10) three times yields the system

$$\begin{aligned} c_1e^x + c_2e^{-x} + c_3e^{2x} + c_4e^{-3x} &= 0 \\ c_1e^x - c_2e^{-x} + 2c_3e^{2x} - 3c_4e^{-3x} &= 0 \\ c_1e^x + c_2e^{-x} + 4c_3e^{2x} + 9c_4e^{-3x} &= 0 \\ c_1e^x - c_2e^{-x} + 8c_3e^{2x} - 27c_4e^{-3x} &= 0. \end{aligned} \quad (9.1.11)$$

If (9.1.11) holds for all  $x$ , then it certainly holds for  $x = 0$ . Therefore

$$\begin{aligned} c_1 + c_2 + c_3 + c_4 &= 0 \\ c_1 - c_2 + 2c_3 - 3c_4 &= 0 \\ c_1 + c_2 + 4c_3 + 9c_4 &= 0 \\ c_1 - c_2 + 8c_3 - 27c_4 &= 0. \end{aligned}$$

The determinant of this system is

$$\begin{aligned} \begin{vmatrix} 1 & 1 & 1 & 1 \\ 1 & -1 & 2 & -3 \\ 1 & 1 & 4 & 9 \\ 1 & -1 & 8 & -27 \end{vmatrix} &= \begin{vmatrix} 1 & 1 & 1 & 1 \\ 0 & -2 & 1 & -4 \\ 0 & 0 & 3 & 8 \\ 0 & -2 & 7 & -28 \end{vmatrix} = \begin{vmatrix} -2 & 1 & -4 \\ 0 & 3 & 8 \\ -2 & 7 & -28 \end{vmatrix} \\ &= \begin{vmatrix} -2 & 1 & -4 \\ 0 & 3 & 8 \\ 0 & 6 & -24 \end{vmatrix} = -2 \begin{vmatrix} 3 & 8 \\ 6 & -24 \end{vmatrix} = 240, \end{aligned} \quad (9.1.12)$$

so the system has only the trivial solution  $c_1 = c_2 = c_3 = c_4 = 0$ . Now Theorem 9.1.2 implies that

$$y = c_1e^x + c_2e^{-x} + c_3e^{2x} + c_4e^{-3x}$$

is the general solution of (9.1.9).

### The Wronskian

We can use the method used in Examples 9.1.1 and 9.1.2 to test  $n$  solutions  $\{y_1, y_2, \dots, y_n\}$  of any  $n$ th order equation  $Ly = 0$  for linear independence on an interval  $(a, b)$  on which the equation is normal. Thus, if  $c_1, c_2, \dots, c_n$  are constants such that

$$c_1y_1 + c_2y_2 + \dots + c_ny_n = 0, \quad a < x < b,$$

then differentiating  $n - 1$  times leads to the  $n \times n$  system of equations

$$\begin{aligned} c_1y_1(x) + c_2y_2(x) + \dots + c_ny_n(x) &= 0 \\ c_1y_1'(x) + c_2y_2'(x) + \dots + c_ny_n'(x) &= 0 \\ &\vdots \\ c_1y_1^{(n-1)}(x) + c_2y_2^{(n-1)}(x) + \dots + c_ny_n^{(n-1)}(x) &= 0 \end{aligned} \quad (9.1.13)$$

for  $c_1, c_2, \dots, c_n$ . For a fixed  $x$ , the determinant of this system is

$$W(x) = \begin{vmatrix} y_1(x) & y_2(x) & \cdots & y_n(x) \\ y_1'(x) & y_2'(x) & \cdots & y_n'(x) \\ \vdots & \vdots & \ddots & \vdots \\ y_1^{(n-1)}(x) & y_2^{(n-1)}(x) & \cdots & y_n^{(n-1)}(x) \end{vmatrix}.$$

We call this determinant the *Wronskian* of  $\{y_1, y_2, \dots, y_n\}$ . If  $W(x) \neq 0$  for some  $x$  in  $(a, b)$  then the system (9.1.13) has only the trivial solution  $c_1 = c_2 = \cdots = c_n = 0$ , and Theorem 9.1.2 implies that

$$y = c_1y_1 + c_2y_2 + \cdots + c_ny_n$$

is the general solution of  $Ly = 0$  on  $(a, b)$ .

The next theorem generalizes Theorem 5.1.4. The proof is sketched in (Exercises 17–20).

**Theorem 9.1.3** *Suppose the homogeneous linear  $n$ th order equation*

$$P_0(x)y^{(n)} + P_1(x)y^{(n-1)} + \cdots + P_n(x)y = 0 \tag{9.1.14}$$

*is normal on  $(a, b)$ , let  $y_1, y_2, \dots, y_n$  be solutions of (9.1.14) on  $(a, b)$ , and let  $x_0$  be in  $(a, b)$ . Then the Wronskian of  $\{y_1, y_2, \dots, y_n\}$  is given by*

$$W(x) = W(x_0) \exp \left\{ - \int_{x_0}^x \frac{P_1(t)}{P_0(t)} dt \right\}, \quad a < x < b. \tag{9.1.15}$$

*Therefore, either  $W$  has no zeros in  $(a, b)$  or  $W \equiv 0$  on  $(a, b)$ .*

Formula (9.1.15) is *Abel's formula*.

The next theorem is analogous to Theorem 5.1.6.

**Theorem 9.1.4** *Suppose  $Ly = 0$  is normal on  $(a, b)$  and let  $y_1, y_2, \dots, y_n$  be  $n$  solutions of  $Ly = 0$  on  $(a, b)$ . Then the following statements are equivalent; that is, they are either all true or all false:*

- (a) *The general solution of  $Ly = 0$  on  $(a, b)$  is  $y = c_1y_1 + c_2y_2 + \cdots + c_ny_n$ .*
- (b)  *$\{y_1, y_2, \dots, y_n\}$  is a fundamental set of solutions of  $Ly = 0$  on  $(a, b)$ .*
- (c)  *$\{y_1, y_2, \dots, y_n\}$  is linearly independent on  $(a, b)$ .*
- (d) *The Wronskian of  $\{y_1, y_2, \dots, y_n\}$  is nonzero at some point in  $(a, b)$ .*
- (e) *The Wronskian of  $\{y_1, y_2, \dots, y_n\}$  is nonzero at all points in  $(a, b)$ .*

**Example 9.1.3** In Example 9.1.1 we saw that the solutions  $y_1 = x^2$ ,  $y_2 = x^3$ , and  $y_3 = 1/x$  of

$$x^3y''' - x^2y'' - 2xy' + 6y = 0$$

are linearly independent on  $(-\infty, 0)$  and  $(0, \infty)$ . Calculate the Wronskian of  $\{y_1, y_2, y_3\}$ .

**Solution** If  $x \neq 0$ , then

$$W(x) = \begin{vmatrix} x^2 & x^3 & \frac{1}{x} \\ 2x & 3x^2 & -\frac{1}{x^2} \\ 2 & 6x & \frac{2}{x^3} \end{vmatrix} = 2x^3 \begin{vmatrix} 1 & x & \frac{1}{x^3} \\ 2 & 3x & -\frac{1}{x^3} \\ 1 & 3x & \frac{1}{x^3} \end{vmatrix},$$

where we factored  $x^2$ ,  $x$ , and 2 out of the first, second, and third rows of  $W(x)$ , respectively. Adding the second row of the last determinant to the first and third rows yields

$$W(x) = 2x^3 \begin{vmatrix} 3 & 4x & 0 \\ 2 & 3x & -\frac{1}{x^3} \\ 3 & 6x & 0 \end{vmatrix} = 2x^3 \left( \frac{1}{x^3} \right) \begin{vmatrix} 3 & 4x \\ 3 & 6x \end{vmatrix} = 12x.$$

Therefore  $W(x) \neq 0$  on  $(-\infty, 0)$  and  $(0, \infty)$ .

**Example 9.1.4** In Example 9.1.2 we saw that the solutions  $y_1 = e^x$ ,  $y_2 = e^{-x}$ ,  $y_3 = e^{2x}$ , and  $y_4 = e^{-3x}$  of

$$y^{(4)} + y''' - 7y'' - y' + 6y = 0$$

are linearly independent on every open interval. Calculate the Wronskian of  $\{y_1, y_2, y_3, y_4\}$ .

**Solution** For all  $x$ ,

$$W(x) = \begin{vmatrix} e^x & e^{-x} & e^{2x} & e^{-3x} \\ e^x & -e^{-x} & 2e^{2x} & -3e^{-3x} \\ e^x & e^{-x} & 4e^{2x} & 9e^{-3x} \\ e^x & -e^{-x} & 8e^{2x} & -27e^{-3x} \end{vmatrix}.$$

Factoring the exponential common factor from each row yields

$$W(x) = e^{-x} \begin{vmatrix} 1 & 1 & 1 & 1 \\ 1 & -1 & 2 & -3 \\ 1 & 1 & 4 & 9 \\ 1 & -1 & 8 & -27 \end{vmatrix} = 240e^{-x},$$

from (9.1.12).

**REMARK:** Under the assumptions of Theorem 9.1.4, it isn't necessary to obtain a formula for  $W(x)$ . Just evaluate  $W(x)$  at a convenient point in  $(a, b)$ , as we did in Examples 9.1.1 and 9.1.2.

**Theorem 9.1.5** Suppose  $c$  is in  $(a, b)$  and  $\alpha_1, \alpha_2, \dots$ , are real numbers, not all zero. Under the assumptions of Theorem 10.3.3, suppose  $y_1$  and  $y_2$  are solutions of (5.1.35) such that

$$\alpha y_i(c) + y_i'(c) + \dots + y_i^{(n-1)}(c) = 0, \quad 1 \leq i \leq n. \quad (9.1.16)$$

Then  $\{y_1, y_2, \dots, y_n\}$  isn't linearly independent on  $(a, b)$ .

**Proof** Since  $\alpha_1, \alpha_2, \dots, \alpha_n$  are not all zero, (9.1.14) implies that

$$\begin{vmatrix} y_1(c) & y_1'(c) & \dots & y_1^{(n-1)}(c) \\ y_2(c) & y_2'(c) & \dots & y_2^{(n-1)}(c) \\ \vdots & \vdots & \ddots & \vdots \\ y_n(c) & y_n'(c) & \dots & y_n^{(n-1)}(c) \end{vmatrix} = 0,$$

so

$$\begin{vmatrix} y_1(c) & y_2(c) & \dots & y_n(c) \\ y_1'(c) & y_2'(c) & \dots & y_n'(c) \\ \vdots & \vdots & \ddots & \vdots \\ y_1^{(n-1)}(c) & y_2^{(n-1)}(c) & \dots & y_n^{(n-1)}(c) \end{vmatrix} = 0$$

and Theorem 9.1.4 implies the stated conclusion.

**General Solution of a Nonhomogeneous Equation**

The next theorem is analogous to Theorem 5.3.2. It shows how to find the general solution of  $Ly = F$  if we know a particular solution of  $Ly = F$  and a fundamental set of solutions of the *complementary equation*  $Ly = 0$ .

**Theorem 9.1.6** *Suppose  $Ly = F$  is normal on  $(a, b)$ . Let  $y_p$  be a particular solution of  $Ly = F$  on  $(a, b)$ , and let  $\{y_1, y_2, \dots, y_n\}$  be a fundamental set of solutions of the complementary equation  $Ly = 0$  on  $(a, b)$ . Then  $y$  is a solution of  $Ly = F$  on  $(a, b)$  if and only if*

$$y = y_p + c_1y_1 + c_2y_2 + \cdots + c_ny_n,$$

where  $c_1, c_2, \dots, c_n$  are constants.

The next theorem is analogous to Theorem 5.3.2.

**Theorem 9.1.7** [The Principle of Superposition] *Suppose for each  $i = 1, 2, \dots, r$ , the function  $y_{p_i}$  is a particular solution of  $Ly = F_i$  on  $(a, b)$ . Then*

$$y_p = y_{p_1} + y_{p_2} + \cdots + y_{p_r}$$

is a particular solution of

$$Ly = F_1(x) + F_2(x) + \cdots + F_r(x)$$

on  $(a, b)$ .

We'll apply Theorems 9.1.6 and 9.1.7 throughout the rest of this chapter.

## 9.1 Exercises

---

1. Verify that the given function is the solution of the initial value problem.

(a)  $x^3y''' - 3x^2y'' + 6xy' - 6y = -\frac{24}{x}$ ,  $y(-1) = 0$ ,  $y'(-1) = 0$ ,  $y''(-1) = 0$ ;

$$y = -6x - 8x^2 - 3x^3 + \frac{1}{x}$$

(b)  $y''' - \frac{1}{x}y'' - y' + \frac{1}{x}y = \frac{x^2 - 4}{x^4}$ ,  $y(1) = \frac{3}{2}$ ,  $y'(1) = \frac{1}{2}$ ,  $y''(1) = 1$ ;

$$y = x + \frac{1}{2x}$$

(c)  $xy''' - y'' - xy' + y = x^2$ ,  $y(1) = 2$ ,  $y'(1) = 5$ ,  $y''(1) = -1$ ;

$$y = -x^2 - 2 + 2e^{(x-1)} - e^{-(x-1)} + 4x$$

(d)  $4x^3y''' + 4x^2y'' - 5xy' + 2y = 30x^2$ ,  $y(1) = 5$ ,  $y'(1) = \frac{17}{2}$ ;

$$y''(1) = \frac{63}{4}; \quad y = 2x^2 \ln x - x^{1/2} + 2x^{-1/2} + 4x^2$$

(e)  $x^4y^{(4)} - 4x^3y''' + 12x^2y'' - 24xy' + 24y = 6x^4$ ,  $y(1) = -2$ ,

$$y'(1) = -9, \quad y''(1) = -27, \quad y'''(1) = -52;$$

$$y = x^4 \ln x + x - 2x^2 + 3x^3 - 4x^4$$

(f)  $xy^{(4)} - y''' - 4xy'' + 4y' = 96x^2$ ,  $y(1) = -5$ ,  $y'(1) = -24$

$$y''(1) = -36; \quad y'''(1) = -48; \quad y = 9 - 12x + 6x^2 - 8x^3$$

2. Solve the initial value problem

$$x^3y''' - x^2y'' - 2xy' + 6y = 0, \quad y(-1) = -4, \quad y'(-1) = -14, \quad y''(-1) = -20.$$

HINT: See Example 9.1.1.

3. Solve the initial value problem

$$y^{(4)} + y''' - 7y'' - y' + 6y = 0, \quad y(0) = 5, \quad y'(0) = -6, \quad y''(0) = 10, \quad y'''(0) = 36.$$

HINT: See Example 9.1.2.

4. Find solutions  $y_1, y_2, \dots, y_n$  of the equation  $y^{(n)} = 0$  that satisfy the initial conditions

$$y_i^{(j)}(x_0) = \begin{cases} 0, & j \neq i - 1, \\ 1, & j = i - 1, \end{cases} \quad 1 \leq i \leq n.$$

5. (a) Verify that the function

$$y = c_1x^3 + c_2x^2 + \frac{c_3}{x}$$

satisfies

$$x^3y''' - x^2y'' - 2xy' + 6y = 0 \tag{A}$$

if  $c_1, c_2,$  and  $c_3$  are constants.

- (b) Use (a) to find solutions  $y_1, y_2,$  and  $y_3$  of (A) such that

$$\begin{aligned} y_1(1) &= 1, & y_1'(1) &= 0, & y_1''(1) &= 0 \\ y_2(1) &= 0, & y_2'(1) &= 1, & y_2''(1) &= 0 \\ y_3(1) &= 0, & y_3'(1) &= 0, & y_3''(1) &= 1. \end{aligned}$$

- (c) Use (b) to find the solution of (A) such that

$$y(1) = k_0, \quad y'(1) = k_1, \quad y''(1) = k_2.$$

6. Verify that the given functions are solutions of the given equation, and show that they form a fundamental set of solutions of the equation on any interval on which the equation is normal.

(a)  $y''' + y'' - y' - y = 0; \quad \{e^x, e^{-x}, xe^{-x}\}$

(b)  $y''' - 3y'' + 7y' - 5y = 0; \quad \{e^x, e^x \cos 2x, e^x \sin 2x\}.$

(c)  $xy''' - y'' - xy' + y = 0; \quad \{e^x, e^{-x}, x\}$

(d)  $x^2y''' + 2xy'' - (x^2 + 2)y = 0; \quad \{e^x/x, e^{-x}/x, 1\}$

(e)  $(x^2 - 2x + 2)y''' - x^2y'' + 2xy' - 2y = 0; \quad \{x, x^2, e^x\}$

(f)  $(2x - 1)y^{(4)} - 4xy''' + (5 - 2x)y'' + 4xy' - 4y = 0; \quad \{x, e^x, e^{-x}, e^{2x}\}$

(g)  $xy^{(4)} - y''' - 4xy' + 4y = 0; \quad \{1, x^2, e^{2x}, e^{-2x}\}$

7. Find the Wronskian  $W$  of a set of three solutions of

$$y''' + 2xy'' + e^x y' - y = 0,$$

given that  $W(0) = 2$ .

8. Find the Wronskian  $W$  of a set of four solutions of

$$y^{(4)} + (\tan x)y''' + x^2y'' + 2xy = 0,$$

given that  $W(\pi/4) = K$ .

9. (a) Evaluate the Wronskian  $W \{e^x, xe^x, x^2e^x\}$ . Evaluate  $W(0)$ .  
 (b) Verify that  $y_1, y_2$ , and  $y_3$  satisfy

$$y''' - 3y'' + 3y' - y = 0. \quad (\text{A})$$

- (c) Use  $W(0)$  from (a) and Abel's formula to calculate  $W(x)$ .  
 (d) What is the general solution of (A)?

10. Compute the Wronskian of the given set of functions.

- |   |                                       |
|---|---------------------------------------|
| (a) $\{1, e^x, e^{-x}\}$  | (b) $\{e^x, e^x \sin x, e^x \cos x\}$ |
| (c) $\{2, x + 1, x^2 + 2\}$   | (d) $\{x, x \ln x, 1/x\}$             |
| (e) $\{1, x, \frac{x^2}{2!}, \frac{x^3}{3!}, \dots, \frac{x^n}{n!}\}$ | (f) $\{e^x, e^{-x}, x\}$              |
| (g) $\{e^x/x, e^{-x}/x, 1\}$  | (h) $\{x, x^2, e^x\}$                 |
| (i) $\{x, x^3, 1/x, 1/x^2\}$  | (j) $\{e^x, e^{-x}, x, e^{2x}\}$      |
| (k) $\{e^{2x}, e^{-2x}, 1, x^2\}$                                     |                                       |

11. Suppose  $Ly = 0$  is normal on  $(a, b)$  and  $x_0$  is in  $(a, b)$ . Use Theorem 9.1.1 to show that  $y \equiv 0$  is the only solution of the initial value problem

$$Ly = 0, \quad y(x_0) = 0, \quad y'(x_0) = 0, \dots, y^{(n-1)}(x_0) = 0,$$

on  $(a, b)$ .

12. Prove: If  $y_1, y_2, \dots, y_n$  are solutions of  $Ly = 0$  and the functions

$$z_i = \sum_{j=1}^n a_{ij}y_j, \quad 1 \leq i \leq n,$$

form a fundamental set of solutions of  $Ly = 0$ , then so do  $y_1, y_2, \dots, y_n$ .

13. Prove: If

$$y = c_1y_1 + c_2y_2 + \dots + c_ky_k + y_p$$

is a solution of a linear equation  $Ly = F$  for every choice of the constants  $c_1, c_2, \dots, c_k$ , then  $Ly_i = 0$  for  $1 \leq i \leq k$ .

14. Suppose  $Ly = 0$  is normal on  $(a, b)$  and let  $x_0$  be in  $(a, b)$ . For  $1 \leq i \leq n$ , let  $y_i$  be the solution of the initial value problem

$$Ly_i = 0, \quad y_i^{(j)}(x_0) = \begin{cases} 0, & j \neq i-1, \\ 1, & j = i-1, \end{cases} \quad 1 \leq i \leq n,$$

where  $x_0$  is an arbitrary point in  $(a, b)$ . Show that any solution of  $Ly = 0$  on  $(a, b)$ , can be written as

$$y = c_1y_1 + c_2y_2 + \dots + c_ny_n,$$

with  $c_j = y^{(j-1)}(x_0)$ .

15. Suppose  $\{y_1, y_2, \dots, y_n\}$  is a fundamental set of solutions of

$$P_0(x)y^{(n)} + P_1(x)y^{(n-1)} + \dots + P_n(x)y = 0$$

on  $(a, b)$ , and let

$$\begin{aligned} z_1 &= a_{11}y_1 + a_{12}y_2 + \dots + a_{1n}y_n \\ z_2 &= a_{21}y_1 + a_{22}y_2 + \dots + a_{2n}y_n \\ &\vdots \\ z_n &= a_{n1}y_1 + a_{n2}y_2 + \dots + a_{nn}y_n, \end{aligned}$$

where the  $\{a_{ij}\}$  are constants. Show that  $\{z_1, z_2, \dots, z_n\}$  is a fundamental set of solutions of (A) if and only if the determinant

$$\begin{vmatrix} a_{11} & a_{12} & \cdots & a_{1n} \\ a_{21} & a_{22} & \cdots & a_{2n} \\ \vdots & \vdots & \ddots & \vdots \\ a_{n1} & a_{n2} & \cdots & a_{nn} \end{vmatrix}$$

is nonzero. HINT: The determinant of a product of  $n \times n$  matrices equals the product of the determinants.

16. Show that  $\{y_1, y_2, \dots, y_n\}$  is linearly dependent on  $(a, b)$  if and only if at least one of the functions  $y_1, y_2, \dots, y_n$  can be written as a linear combination of the others on  $(a, b)$ .

Take the following as a hint in Exercises 17–19:

By the definition of determinant,

$$\begin{vmatrix} a_{11} & a_{12} & \cdots & a_{1n} \\ a_{21} & a_{22} & \cdots & a_{2n} \\ \vdots & \vdots & \ddots & \vdots \\ a_{n1} & a_{n2} & \cdots & a_{nn} \end{vmatrix} = \sum \pm a_{1i_1} a_{2i_2} \cdots a_{ni_n},$$

where the sum is over all permutations  $(i_1, i_2, \dots, i_n)$  of  $(1, 2, \dots, n)$  and the choice of + or – in each term depends only on the permutation associated with that term.

17. Prove: If

$$A(u_1, u_2, \dots, u_n) = \begin{vmatrix} a_{11} & a_{12} & \cdots & a_{1n} \\ a_{21} & a_{22} & \cdots & a_{2n} \\ \vdots & \vdots & \ddots & \vdots \\ a_{n-1,1} & a_{n-1,2} & \cdots & a_{n-1,n} \\ u_1 & u_2 & \cdots & u_n \end{vmatrix},$$

then

$$A(u_1 + v_1, u_2 + v_2, \dots, u_n + v_n) = A(u_1, u_2, \dots, u_n) + A(v_1, v_2, \dots, v_n).$$



18. Let

$$F = \begin{vmatrix} f_{11} & f_{12} & \cdots & f_{1n} \\ f_{21} & f_{22} & \cdots & f_{2n} \\ \vdots & \vdots & \ddots & \vdots \\ f_{n1} & f_{n2} & \cdots & f_{nn} \end{vmatrix},$$

where  $f_{ij}$  ( $1 \leq i, j \leq n$ ) is differentiable. Show that

$$F' = F_1 + F_2 + \cdots + F_n,$$

where  $F_i$  is the determinant obtained by differentiating the  $i$ th row of  $F$ .

19. Use Exercise 18 to show that if  $W$  is the Wronskian of the  $n$ -times differentiable functions  $y_1, y_2, \dots, y_n$ , then

$$W' = \begin{vmatrix} y_1 & y_2 & \cdots & y_n \\ y_1' & y_2' & \cdots & y_n' \\ \vdots & \vdots & \ddots & \vdots \\ y_1^{(n-2)} & y_2^{(n-2)} & \cdots & y_n^{(n-2)} \\ y_1^{(n)} & y_2^{(n)} & \cdots & y_n^{(n)} \end{vmatrix}.$$

20. Use Exercises 17 and 19 to show that if  $W$  is the Wronskian of solutions  $\{y_1, y_2, \dots, y_n\}$  of the normal equation

$$P_0(x)y^{(n)} + P_1(x)y^{(n-1)} + \cdots + P_n(x)y = 0, \quad (\text{A})$$

then  $W' = -P_1W/P_0$ . Derive Abel's formula (Eqn. (9.1.15)) from this. HINT: Use (A) to write  $y^{(n)}$  in terms of  $y, y', \dots, y^{(n-1)}$ .

21. Prove Theorem 9.1.6.

22. Prove Theorem 9.1.7.

23. Show that if the Wronskian of the  $n$ -times continuously differentiable functions  $\{y_1, y_2, \dots, y_n\}$  has no zeros in  $(a, b)$ , then the differential equation obtained by expanding the determinant

$$\begin{vmatrix} y & y_1 & y_2 & \cdots & y_n \\ y' & y_1' & y_2' & \cdots & y_n' \\ \vdots & \vdots & \vdots & \ddots & \vdots \\ y^{(n)} & y_1^{(n)} & y_2^{(n)} & \cdots & y_n^{(n)} \end{vmatrix} = 0,$$

in cofactors of its first column is normal and has  $\{y_1, y_2, \dots, y_n\}$  as a fundamental set of solutions on  $(a, b)$ .

24. Use the method suggested by Exercise 23 to find a linear homogeneous equation such that the given set of functions is a fundamental set of solutions on intervals on which the Wronskian of the set has no zeros.

(a)  $\{x, x^2 - 1, x^2 + 1\}$

(b)  $\{e^x, e^{-x}, x\}$

(c)  $\{e^x, xe^{-x}, 1\}$

(d)  $\{x, x^2, e^x\}$

$$\begin{array}{ll}
 \text{(e)} \{x, x^2, 1/x\} & \text{(f)} \{x+1, e^x, e^{3x}\} \\
 \text{(g)} \{x, x^3, 1/x, 1/x^2\} & \text{(h)} \{x, x \ln x, 1/x, x^2\} \\
 \text{(i)} \{e^x, e^{-x}, x, e^{2x}\} & \text{(j)} \{e^{2x}, e^{-2x}, 1, x^2\}
 \end{array}$$

## 9.2 HIGHER ORDER CONSTANT COEFFICIENT HOMOGENEOUS EQUATIONS

If  $a_0, a_1, \dots, a_n$  are constants and  $a_0 \neq 0$ , then

$$a_0 y^{(n)} + a_1 y^{(n-1)} + \dots + a_n y = F(x)$$

is said to be a *constant coefficient equation*. In this section we consider the homogeneous constant coefficient equation

$$a_0 y^{(n)} + a_1 y^{(n-1)} + \dots + a_n y = 0. \quad (9.2.1)$$

Since (9.2.1) is normal on  $(-\infty, \infty)$ , the theorems in Section 9.1 all apply with  $(a, b) = (-\infty, \infty)$ .

As in Section 5.2, we call

$$p(r) = a_0 r^n + a_1 r^{n-1} + \dots + a_n \quad (9.2.2)$$

the *characteristic polynomial* of (9.2.1). We saw in Section 5.2 that when  $n = 2$  the solutions of (9.2.1) are determined by the zeros of the characteristic polynomial. This is also true when  $n > 2$ , but the situation is more complicated in this case. Consequently, we take a different approach here than in Section 5.2.

If  $k$  is a positive integer, let  $D^k$  stand for the  $k$ -th derivative operator; that is

$$D^k y = y^{(k)}.$$

If

$$q(r) = b_0 r^m + b_1 r^{m-1} + \dots + b_m$$

is an arbitrary polynomial, define the operator

$$q(D) = b_0 D^m + b_1 D^{m-1} + \dots + b_m$$

such that

$$q(D)y = (b_0 D^m + b_1 D^{m-1} + \dots + b_m)y = b_0 y^{(m)} + b_1 y^{(m-1)} + \dots + b_m y$$

whenever  $y$  is a function with  $m$  derivatives. We call  $q(D)$  a *polynomial operator*.

With  $p$  as in (9.2.2),

$$p(D) = a_0 D^n + a_1 D^{n-1} + \dots + a_n,$$

so (9.2.1) can be written as  $p(D)y = 0$ . If  $r$  is a constant then

$$\begin{aligned}
 p(D)e^{rx} &= (a_0 D^n e^{rx} + a_1 D^{n-1} e^{rx} + \dots + a_n e^{rx}) \\
 &= (a_0 r^n + a_1 r^{n-1} + \dots + a_n) e^{rx};
 \end{aligned}$$

that is

$$p(D)(e^{rx}) = p(r)e^{rx}.$$

This shows that  $y = e^{rx}$  is a solution of (9.2.1) if  $p(r) = 0$ . In the simplest case, where  $p$  has  $n$  distinct real zeros  $r_1, r_2, \dots, r_n$ , this argument yields  $n$  solutions

$$y_1 = e^{r_1 x}, \quad y_2 = e^{r_2 x}, \quad \dots, \quad y_n = e^{r_n x}.$$

It can be shown (Exercise 39) that the Wronskian of  $\{e^{r_1 x}, e^{r_2 x}, \dots, e^{r_n x}\}$  is nonzero if  $r_1, r_2, \dots, r_n$  are distinct; hence,  $\{e^{r_1 x}, e^{r_2 x}, \dots, e^{r_n x}\}$  is a fundamental set of solutions of  $p(D)y = 0$  in this case.

**Example 9.2.1**

(a) Find the general solution of

$$y''' - 6y'' + 11y' - 6y = 0. \quad (9.2.3)$$

(b) Solve the initial value problem

$$y''' - 6y'' + 11y' - 6y = 0, \quad y(0) = 4, \quad y'(0) = 5, \quad y''(0) = 9. \quad (9.2.4)$$

**Solution** The characteristic polynomial of (9.2.3) is

$$p(r) = r^3 - 6r^2 + 11r - 6 = (r - 1)(r - 2)(r - 3).$$

Therefore  $\{e^x, e^{2x}, e^{3x}\}$  is a set of solutions of (9.2.3). It is a fundamental set, since its Wronskian is

$$W(x) = \begin{vmatrix} e^x & e^{2x} & e^{3x} \\ e^x & 2e^{2x} & 3e^{3x} \\ e^x & 4e^{2x} & 9e^{3x} \end{vmatrix} = e^{6x} \begin{vmatrix} 1 & 1 & 1 \\ 1 & 2 & 3 \\ 1 & 4 & 9 \end{vmatrix} = 2e^{6x} \neq 0.$$

Therefore the general solution of (9.2.3) is

$$y = c_1 e^x + c_2 e^{2x} + c_3 e^{3x}. \quad (9.2.5)$$

**SOLUTION(b)** We must determine  $c_1$ ,  $c_2$  and  $c_3$  in (9.2.5) so that  $y$  satisfies the initial conditions in (9.2.4). Differentiating (9.2.5) twice yields

$$\begin{aligned} y' &= c_1 e^x + 2c_2 e^{2x} + 3c_3 e^{3x} \\ y'' &= c_1 e^x + 4c_2 e^{2x} + 9c_3 e^{3x}. \end{aligned} \quad (9.2.6)$$

Setting  $x = 0$  in (9.2.5) and (9.2.6) and imposing the initial conditions yields

$$\begin{aligned} c_1 + c_2 + c_3 &= 4 \\ c_1 + 2c_2 + 3c_3 &= 5 \\ c_1 + 4c_2 + 9c_3 &= 9. \end{aligned}$$

The solution of this system is  $c_1 = 4$ ,  $c_2 = -1$ ,  $c_3 = 1$ . Therefore the solution of (9.2.4) is

$$y = 4e^x - e^{2x} + e^{3x}$$

(Figure 9.2.1). ■Now we consider the case where the characteristic polynomial (9.2.2) does not have  $n$  distinct real zeros. For this purpose it is useful to define what we mean by a factorization of a polynomial operator. We begin with an example.**Example 9.2.2** Consider the polynomial

$$p(r) = r^3 - r^2 + r - 1$$

and the associated polynomial operator

$$p(D) = D^3 - D^2 + D - 1.$$

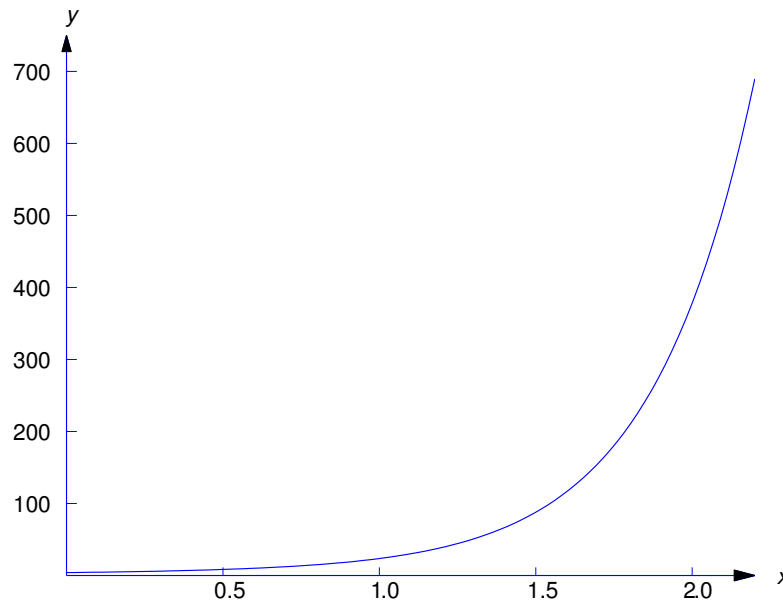

Figure 9.2.1  $y = 4e^x - e^{2x} + e^{3x}$

Since  $p(r)$  can be factored as

$$p(r) = (r - 1)(r^2 + 1) = (r^2 + 1)(r - 1),$$

it's reasonable to expect that  $p(D)$  can be factored as

$$p(D) = (D - 1)(D^2 + 1) = (D^2 + 1)(D - 1). \tag{9.2.7}$$

However, before we can make this assertion we must *define* what we mean by saying that two operators are equal, and what we mean by the products of operators in (9.2.7). We say that two operators are equal if they apply to the same functions and always produce the same result. The definitions of the products in (9.2.7) is this: if  $y$  is any three-times differentiable function then

- (a)  $(D - 1)(D^2 + 1)y$  is the function obtained by first applying  $D^2 + 1$  to  $y$  and then applying  $D - 1$  to the resulting function
- (b)  $(D^2 + 1)(D - 1)y$  is the function obtained by first applying  $D - 1$  to  $y$  and then applying  $D^2 + 1$  to the resulting function.

From (a),

$$\begin{aligned} (D - 1)(D^2 + 1)y &= (D - 1)[(D^2 + 1)y] \\ &= (D - 1)(y'' + y) = D(y'' + y) - (y'' + y) \\ &= (y''' + y') - (y'' + y) \\ &= y''' - y'' + y' - y = (D^3 - D^2 + D - 1)y. \end{aligned} \tag{9.2.8}$$

This implies that

$$(D - 1)(D^2 + 1) = (D^3 - D^2 + D - 1).$$

From (b),

$$\begin{aligned}
 (D^2 + 1)(D - 1)y &= (D^2 + 1)[(D - 1)y] \\
 &= (D^2 + 1)(y' - y) = D^2(y' - y) + (y' - y) \\
 &= (y''' - y'') + (y' - y) \\
 &= y''' - y'' + y' - y = (D^3 - D^2 + D - 1)y, \\
 (D^2 + 1)(D - 1) &= (D^3 - D^2 + D - 1),
 \end{aligned} \tag{9.2.9}$$

which completes the justification of (9.2.7).

**Example 9.2.3** Use the result of Example 9.2.2 to find the general solution of

$$y''' - y'' + y' - y = 0. \tag{9.2.10}$$

**Solution** From (9.2.8), we can rewrite (9.2.10) as

$$(D - 1)(D^2 + 1)y = 0,$$

which implies that any solution of  $(D^2 + 1)y = 0$  is a solution of (9.2.10). Therefore  $y_1 = \cos x$  and  $y_2 = \sin x$  are solutions of (9.2.10).

From (9.2.9), we can rewrite (9.2.10) as

$$(D^2 + 1)(D - 1)y = 0,$$

which implies that any solution of  $(D - 1)y = 0$  is a solution of (9.2.10). Therefore  $y_3 = e^x$  is solution of (9.2.10).

The Wronskian of  $\{e^x, \cos x, \sin x\}$  is

$$W(x) = \begin{vmatrix} \cos x & \sin x & e^x \\ -\sin x & \cos x & e^x \\ -\cos x & -\sin x & e^x \end{vmatrix}.$$

Since

$$W(0) = \begin{vmatrix} 1 & 0 & 1 \\ 0 & 1 & 1 \\ -1 & 0 & 1 \end{vmatrix} = 2,$$

$\{\cos x, \sin x, e^x\}$  is linearly independent and

$$y = c_1 \cos x + c_2 \sin x + c_3 e^x$$

is the general solution of (9.2.10).

**Example 9.2.4** Find the general solution of

$$y^{(4)} - 16y = 0. \tag{9.2.11}$$

**Solution** The characteristic polynomial of (9.2.11) is

$$p(r) = r^4 - 16 = (r^2 - 4)(r^2 + 4) = (r - 2)(r + 2)(r^2 + 4).$$

By arguments similar to those used in Examples 9.2.2 and 9.2.3, it can be shown that (9.2.11) can be written as

$$(D^2 + 4)(D + 2)(D - 2)y = 0$$

or

$$(D^2 + 4)(D - 2)(D + 2)y = 0$$

or

$$(D - 2)(D + 2)(D^2 + 4)y = 0.$$

Therefore  $y$  is a solution of (9.2.11) if it's a solution of any of the three equations

$$(D - 2)y = 0, \quad (D + 2)y = 0, \quad (D^2 + 4)y = 0.$$

Hence,  $\{e^{2x}, e^{-2x}, \cos 2x, \sin 2x\}$  is a set of solutions of (9.2.11). The Wronskian of this set is

$$W(x) = \begin{vmatrix} e^{2x} & e^{-2x} & \cos 2x & \sin 2x \\ 2e^{2x} & -2e^{-2x} & -2\sin 2x & 2\cos 2x \\ 4e^{2x} & 4e^{-2x} & -4\cos 2x & -4\sin 2x \\ 8e^{2x} & -8e^{-2x} & 8\sin 2x & -8\cos 2x \end{vmatrix}.$$

Since

$$W(0) = \begin{vmatrix} 1 & 1 & 1 & 0 \\ 2 & -2 & 0 & 2 \\ 4 & 4 & -4 & 0 \\ 8 & -8 & 0 & -8 \end{vmatrix} = -512,$$

 $\{e^{2x}, e^{-2x}, \cos 2x, \sin 2x\}$  is linearly independent, and

$$y_1 = c_1 e^{2x} + c_2 e^{-2x} + c_3 \cos 2x + c_4 \sin 2x$$

is the general solution of (9.2.11).

It is known from algebra that every polynomial

$$p(r) = a_0 r^n + a_1 r^{n-1} + \cdots + a_n$$

with real coefficients can be factored as

$$p(r) = a_0 p_1(r) p_2(r) \cdots p_k(r),$$

where no pair of the polynomials  $p_1, p_2, \dots, p_k$  has a common factor and each is either of the form

$$p_j(r) = (r - r_j)^{m_j}, \quad (9.2.12)$$

where  $r_j$  is real and  $m_j$  is a positive integer, or

$$p_j(r) = [(r - \lambda_j)^2 + \omega_j^2]^{m_j}, \quad (9.2.13)$$

where  $\lambda_j$  and  $\omega_j$  are real,  $\omega_j \neq 0$ , and  $m_j$  is a positive integer. If (9.2.12) holds then  $r_j$  is a real zero of  $p$ , while if (9.2.13) holds then  $\lambda + i\omega$  and  $\lambda - i\omega$  are complex conjugate zeros of  $p$ . In either case,  $m_j$  is the *multiplicity* of the zero(s).

By arguments similar to those used in our examples, it can be shown that

$$p(D) = a_0 p_1(D) p_2(D) \cdots p_k(D) \quad (9.2.14)$$

and that the order of the factors on the right can be chosen arbitrarily. Therefore, if  $p_j(D)y = 0$  for some  $j$  then  $p(D)y = 0$ . To see this, we simply rewrite (9.2.14) so that  $p_j(D)$  is applied first. Therefore the

problem of finding solutions of  $p(D)y = 0$  with  $p$  as in (9.2.14) reduces to finding solutions of each of these equations

$$p_j(D)y = 0, \quad 1 \leq j \leq k,$$

where  $p_j$  is a power of a first degree term or of an irreducible quadratic. To find a fundamental set of solutions  $\{y_1, y_2, \dots, y_n\}$  of  $p(D)y = 0$ , we find fundamental set of solutions of each of the equations and take  $\{y_1, y_2, \dots, y_n\}$  to be the set of all functions in these separate fundamental sets. In Exercise 40 we sketch the proof that  $\{y_1, y_2, \dots, y_n\}$  is linearly independent, and therefore a fundamental set of solutions of  $p(D)y = 0$ .

To apply this procedure to general homogeneous constant coefficient equations, we must be able to find fundamental sets of solutions of equations of the form

$$(D - a)^m y = 0$$

and

$$[(D - \lambda)^2 + \omega^2]^m y = 0,$$

where  $m$  is an arbitrary positive integer. The next two theorems show how to do this.

**Theorem 9.2.1** *If  $m$  is a positive integer, then*

$$\{e^{ax}, xe^{ax}, \dots, x^{m-1}e^{ax}\} \tag{9.2.15}$$

*is a fundamental set of solutions of*

$$(D - a)^m y = 0. \tag{9.2.16}$$

**Proof** We'll show that if

$$f(x) = c_1 + c_2x + \dots + c_mx^{m-1}$$

is an arbitrary polynomial of degree  $\leq m - 1$ , then  $y = e^{ax}f$  is a solution of (9.2.16). First note that if  $g$  is any differentiable function then

$$(D - a)e^{ax}g = De^{ax}g - ae^{ax}g = ae^{ax}g + e^{ax}g' - ae^{ax}g,$$

so

$$(D - a)e^{ax}g = e^{ax}g'. \tag{9.2.17}$$

Therefore

$$\begin{aligned} (D - a)e^{ax}f &= e^{ax}f' && \text{(from (9.2.17) with } g = f) \\ (D - a)^2e^{ax}f &= (D - a)e^{ax}f' = e^{ax}f'' && \text{(from (9.2.17) with } g = f') \\ (D - a)^3e^{ax}f &= (D - a)e^{ax}f'' = e^{ax}f''' && \text{(from (9.2.17) with } g = f'') \\ &\vdots && \\ (D - a)^me^{ax}f &= (D - a)e^{ax}f^{(m-1)} = e^{ax}f^{(m)} && \text{(from (9.2.17) with } g = f^{(m-1)}). \end{aligned}$$

Since  $f^{(m)} = 0$ , the last equation implies that  $y = e^{ax}f$  is a solution of (9.2.16) if  $f$  is any polynomial of degree  $\leq m - 1$ . In particular, each function in (9.2.15) is a solution of (9.2.16). To see that (9.2.15) is linearly independent (and therefore a fundamental set of solutions of (9.2.16)), note that if

$$c_1e^{ax} + c_2xe^{ax} + c \dots + c_{m-1}x^{m-1}e^{ax} = 0$$

for all  $x$  in some interval  $(a, b)$ , then

$$c_1 + c_2x + c \dots + c_{m-1}x^{m-1} = 0$$

for all  $x$  in  $(a, b)$ . However, we know from algebra that if this polynomial has more than  $m - 1$  zeros then  $c_1 = c_2 = \dots = c_n = 0$ .

**Example 9.2.5** Find the general solution of

$$y''' + 3y'' + 3y' + y = 0. \quad (9.2.18)$$

**Solution** The characteristic polynomial of (9.2.18) is

$$p(r) = r^3 + 3r^2 + 3r + 1 = (r + 1)^3.$$

Therefore (9.2.18) can be written as

$$(D + 1)^3 y = 0,$$

so Theorem 9.2.1 implies that the general solution of (9.2.18) is

$$y = e^{-x}(c_1 + c_2x + c_3x^2). \quad \blacksquare$$

The proof of the next theorem is sketched in Exercise 41.

**Theorem 9.2.2** *If  $\omega \neq 0$  and  $m$  is a positive integer, then*

$$\left\{ \begin{array}{l} e^{\lambda x} \cos \omega x, x e^{\lambda x} \cos \omega x, \dots, x^{m-1} e^{\lambda x} \cos \omega x, \\ e^{\lambda x} \sin \omega x, x e^{\lambda x} \sin \omega x, \dots, x^{m-1} e^{\lambda x} \sin \omega x \end{array} \right\}$$

*is a fundamental set of solutions of*

$$[(D - \lambda)^2 + \omega^2]^m y = 0.$$

**Example 9.2.6** Find the general solution of

$$(D^2 + 4D + 13)^3 y = 0. \quad (9.2.19)$$

**Solution** The characteristic polynomial of (9.2.19) is

$$p(r) = (r^2 + 4r + 13)^3 = ((r + 2)^2 + 9)^3.$$

Therefore (9.2.19) can be written as

$$[(D + 2)^2 + 9]^3 y = 0,$$

so Theorem 9.2.2 implies that the general solution of (9.2.19) is

$$y = (a_1 + a_2x + a_3x^2)e^{-2x} \cos 3x + (b_1 + b_2x + b_3x^2)e^{-2x} \sin 3x.$$

**Example 9.2.7** Find the general solution of

$$y^{(4)} + 4y''' + 6y'' + 4y' = 0. \quad (9.2.20)$$

**Solution** The characteristic polynomial of (9.2.20) is

$$\begin{aligned} p(r) &= r^4 + 4r^3 + 6r^2 + 4r \\ &= r(r^3 + 4r^2 + 6r + 4) \\ &= r(r + 2)(r^2 + 2r + 2) \\ &= r(r + 2)[(r + 1)^2 + 1]. \end{aligned}$$



Therefore (9.2.20) can be written as

$$[(D + 1)^2 + 1](D + 2)Dy = 0.$$

Fundamental sets of solutions of

$$[(D + 1)^2 + 1]y = 0, \quad (D + 2)y = 0, \quad \text{and} \quad Dy = 0.$$

are given by

$$\{e^{-x} \cos x, e^{-x} \sin x\}, \quad \{e^{-2x}\}, \quad \text{and} \quad \{1\},$$

respectively. Therefore the general solution of (9.2.20) is

$$y = e^{-x}(c_1 \cos x + c_2 \sin x) + c_3 e^{-2x} + c_4.$$

**Example 9.2.8** Find a fundamental set of solutions of

$$[(D + 1)^2 + 1]^2(D - 1)^3(D + 1)D^2y = 0. \quad (9.2.21)$$

**Solution** A fundamental set of solutions of (9.2.21) can be obtained by combining fundamental sets of solutions of

$$\begin{aligned} [(D + 1)^2 + 1]^2 y &= 0, & (D - 1)^3 y &= 0, \\ (D + 1)y &= 0, & \text{and} & D^2 y = 0. \end{aligned}$$

Fundamental sets of solutions of these equations are given by

$$\begin{aligned} \{e^{-x} \cos x, x e^{-x} \cos x, e^{-x} \sin x, x e^{-x} \sin x\}, & \quad \{e^x, x e^x, x^2 e^x\}, \\ \{e^{-x}\}, & \quad \text{and} \quad \{1, x\}, \end{aligned}$$

respectively. These ten functions form a fundamental set of solutions of (9.2.21).

## 9.2 Exercises

---

In Exercises 1–14 find the general solution.

- |  |   |
|--|---|
| 1. $y''' - 3y'' + 3y' - y = 0$                 | 2. $y^{(4)} + 8y'' - 9y = 0$                |
| 3. $y''' - y'' + 16y' - 16y = 0$               | 4. $2y''' + 3y'' - 2y' - 3y = 0$            |
| 5. $y''' + 5y'' + 9y' + 5y = 0$                | 6. $4y''' - 8y'' + 5y' - y = 0$             |
| 7. $27y''' + 27y'' + 9y' + y = 0$              | 8. $y^{(4)} + y'' = 0$                      |
| 9. $y^{(4)} - 16y = 0$                         | 10. $y^{(4)} + 12y'' + 36y = 0$             |
| 11. $16y^{(4)} - 72y'' + 81y = 0$              | 12. $6y^{(4)} + 5y''' + 7y'' + 5y' + y = 0$ |
| 13. $4y^{(4)} + 12y''' + 3y'' - 13y' - 6y = 0$ |   |
| 14. $y^{(4)} - 4y''' + 7y'' - 6y' + 2y = 0$    |   |

In Exercises 15–27 solve the initial value problem. Where indicated by C/G, graph the solution.

15.  $y''' - 2y'' + 4y' - 8y = 0$ ,  $y(0) = 2$ ,  $y'(0) = -2$ ,  $y''(0) = 0$
16.  $y''' + 3y'' - y' - 3y = 0$ ,  $y(0) = 0$ ,  $y'(0) = 14$ ,  $y''(0) = -40$
17. C/G  $y''' - y'' - y' + y = 0$ ,  $y(0) = -2$ ,  $y'(0) = 9$ ,  $y''(0) = 4$
18. C/G  $y''' - 2y' - 4y = 0$ ,  $y(0) = 6$ ,  $y'(0) = 3$ ,  $y''(0) = 22$
19. C/G  
 $3y''' - y'' - 7y' + 5y = 0$ ,  $y(0) = \frac{14}{5}$ ,  $y'(0) = 0$ ,  $y''(0) = 10$
20.  $y''' - 6y'' + 12y' - 8y = 0$ ,  $y(0) = 1$ ,  $y'(0) = -1$ ,  $y''(0) = -4$
21.  $2y''' - 11y'' + 12y' + 9y = 0$ ,  $y(0) = 6$ ,  $y'(0) = 3$ ,  $y''(0) = 13$
22.  $8y''' - 4y'' - 2y' + y = 0$ ,  $y(0) = 4$ ,  $y'(0) = -3$ ,  $y''(0) = -1$
23.  $y^{(4)} - 16y = 0$ ,  $y(0) = 2$ ,  $y'(0) = 2$ ,  $y''(0) = -2$ ,  $y'''(0) = 0$
24.  $y^{(4)} - 6y''' + 7y'' + 6y' - 8y = 0$ ,  $y(0) = -2$ ,  $y'(0) = -8$ ,  $y''(0) = -14$ ,  
 $y'''(0) = -62$
25.  $4y^{(4)} - 13y'' + 9y = 0$ ,  $y(0) = 1$ ,  $y'(0) = 3$ ,  $y''(0) = 1$ ,  $y'''(0) = 3$
26.  $y^{(4)} + 2y''' - 2y'' - 8y' - 8y = 0$ ,  $y(0) = 5$ ,  $y'(0) = -2$ ,  $y''(0) = 6$ ,  $y'''(0) = 8$
27. C/G  $4y^{(4)} + 8y''' + 19y'' + 32y' + 12y = 0$ ,  $y(0) = 3$ ,  $y'(0) = -3$ ,  $y''(0) = -\frac{7}{2}$ ,  
 $y'''(0) = \frac{31}{4}$
28. Find a fundamental set of solutions of the given equation, and verify that it's a fundamental set by evaluating its Wronskian at  $x = 0$ .
- (a)  $(D - 1)^2(D - 2)y = 0$                       (b)  $(D^2 + 4)(D - 3)y = 0$
- (c)  $(D^2 + 2D + 2)(D - 1)y = 0$                       (d)  $D^3(D - 1)y = 0$
- (e)  $(D^2 - 1)(D^2 + 1)y = 0$                       (f)  $(D^2 - 2D + 2)(D^2 + 1)y = 0$

In Exercises 29–38 find a fundamental set of solutions.

29.  $(D^2 + 6D + 13)(D - 2)^2 D^3 y = 0$
30.  $(D - 1)^2(2D - 1)^3(D^2 + 1)y = 0$
31.  $(D^2 + 9)^3 D^2 y = 0$                       32.  $(D - 2)^3(D + 1)^2 D y = 0$
33.  $(D^2 + 1)(D^2 + 9)^2(D - 2)y = 0$                       34.  $(D^4 - 16)^2 y = 0$
35.  $(4D^2 + 4D + 9)^3 y = 0$                       36.  $D^3(D - 2)^2(D^2 + 4)^2 y = 0$
37.  $(4D^2 + 1)^2(9D^2 + 4)^3 y = 0$                       38.  $[(D - 1)^4 - 16] y = 0$

39. It can be shown that

$$\begin{vmatrix} 1 & 1 & \cdots & 1 \\ a_1 & a_2 & \cdots & a_n \\ a_1^2 & a_2^2 & \cdots & a_n^2 \\ \vdots & \vdots & \ddots & \vdots \\ a_1^{n-1} & a_2^{n-1} & \cdots & a_n^{n-1} \end{vmatrix} = \prod_{1 \leq i < j \leq n} (a_j - a_i), \quad (\text{A})$$

where the left side is the *Vandermonde determinant* and the right side is the product of all factors of the form  $(a_j - a_i)$  with  $i$  and  $j$  between 1 and  $n$  and  $i < j$ .

- (a) Verify (A) for  $n = 2$  and  $n = 3$ .  
 (b) Find the Wronskian of  $\{e^{a_1x}, e^{a_2x}, \dots, e^{a_nx}\}$ .

40. A theorem from algebra says that if  $P_1$  and  $P_2$  are polynomials with no common factors then there are polynomials  $Q_1$  and  $Q_2$  such that

$$Q_1P_1 + Q_2P_2 = 1.$$

This implies that

$$Q_1(D)P_1(D)y + Q_2(D)P_2(D)y = y$$

for every function  $y$  with enough derivatives for the left side to be defined.

- (a) Use this to show that if  $P_1$  and  $P_2$  have no common factors and

$$P_1(D)y = P_2(D)y = 0$$

then  $y = 0$ .

- (b) Suppose  $P_1$  and  $P_2$  are polynomials with no common factors. Let  $u_1, \dots, u_r$  be linearly independent solutions of  $P_1(D)y = 0$  and let  $v_1, \dots, v_s$  be linearly independent solutions of  $P_2(D)y = 0$ . Use (a) to show that  $\{u_1, \dots, u_r, v_1, \dots, v_s\}$  is a linearly independent set.  
 (c) Suppose the characteristic polynomial of the constant coefficient equation

$$a_0y^{(n)} + a_1y^{(n-1)} + \cdots + a_ny = 0 \quad (\text{A})$$

has the factorization

$$p(r) = a_0p_1(r)p_2(r) \cdots p_k(r),$$

where each  $p_j$  is of the form

$$p_j(r) = (r - r_j)^{n_j} \text{ or } p_j(r) = [(r - \lambda_j)^2 + \omega_j^2]^{m_j} \quad (\omega_j > 0)$$

and no two of the polynomials  $p_1, p_2, \dots, p_k$  have a common factor. Show that we can find a fundamental set of solutions  $\{y_1, y_2, \dots, y_n\}$  of (A) by finding a fundamental set of solutions of each of the equations

$$p_j(D)y = 0, \quad 1 \leq j \leq k,$$

and taking  $\{y_1, y_2, \dots, y_n\}$  to be the set of all functions in these separate fundamental sets.

41. (a) Show that if

$$z = p(x) \cos \omega x + q(x) \sin \omega x, \quad (\text{A})$$

where  $p$  and  $q$  are polynomials of degree  $\leq k$ , then

$$(D^2 + \omega^2)z = p_1(x) \cos \omega x + q_1(x) \sin \omega x,$$

where  $p_1$  and  $q_1$  are polynomials of degree  $\leq k - 1$ .

- (b) Apply (a)  $m$  times to show that if  $z$  is of the form (A) where  $p$  and  $q$  are polynomial of degree  $\leq m - 1$ , then

$$(D^2 + \omega^2)^m z = 0. \quad (\text{B})$$

- (c) Use Eqn. (9.2.17) to show that if  $y = e^{\lambda x} z$  then

$$[(D - \lambda)^2 + \omega^2]^m y = e^{\lambda x} (D^2 + \omega^2)^m z.$$

- (d) Conclude from (b) and (c) that if  $p$  and  $q$  are arbitrary polynomials of degree  $\leq m - 1$  then

$$y = e^{\lambda x} (p(x) \cos \omega x + q(x) \sin \omega x)$$

is a solution of

$$[(D - \lambda)^2 + \omega^2]^m y = 0. \quad (\text{C})$$

- (e) Conclude from (d) that the functions

$$\begin{aligned} e^{\lambda x} \cos \omega x, x e^{\lambda x} \cos \omega x, \dots, x^{m-1} e^{\lambda x} \cos \omega x, \\ e^{\lambda x} \sin \omega x, x e^{\lambda x} \sin \omega x, \dots, x^{m-1} e^{\lambda x} \sin \omega x \end{aligned} \quad (\text{D})$$

are all solutions of (C).

- (f) Complete the proof of Theorem 9.2.2 by showing that the functions in (D) are linearly independent.
42. (a) Use the trigonometric identities

$$\begin{aligned} \cos(A + B) &= \cos A \cos B - \sin A \sin B \\ \sin(A + B) &= \cos A \sin B + \sin A \cos B \end{aligned}$$

to show that

$$(\cos A + i \sin A)(\cos B + i \sin B) = \cos(A + B) + i \sin(A + B).$$

- (b) Apply (a) repeatedly to show that if  $n$  is a positive integer then

$$\prod_{k=1}^n (\cos A_k + i \sin A_k) = \cos(A_1 + A_2 + \dots + A_n) + i \sin(A_1 + A_2 + \dots + A_n).$$

- (c) Infer from (b) that if  $n$  is a positive integer then

$$(\cos \theta + i \sin \theta)^n = \cos n\theta + i \sin n\theta. \quad (\text{A})$$

- (d) Show that (A) also holds if  $n = 0$  or a negative integer. HINT: Verify by direct calculation that

$$(\cos \theta + i \sin \theta)^{-1} = (\cos \theta - i \sin \theta).$$

Then replace  $\theta$  by  $-\theta$  in (A).

(e) Now suppose  $n$  is a positive integer. Infer from (A) that if

$$z_k = \cos\left(\frac{2k\pi}{n}\right) + i \sin\left(\frac{2k\pi}{n}\right), \quad k = 0, 1, \dots, n-1,$$

and

$$\zeta_k = \cos\left(\frac{(2k+1)\pi}{n}\right) + i \sin\left(\frac{(2k+1)\pi}{n}\right), \quad k = 0, 1, \dots, n-1,$$

then

$$z_k^n = 1 \quad \text{and} \quad \zeta_k^n = -1, \quad k = 0, 1, \dots, n-1.$$

(Why don't we also consider other integer values for  $k$ ?)

(f) Let  $\rho$  be a positive number. Use (e) to show that

$$z^n - \rho = (z - \rho^{1/n}z_0)(z - \rho^{1/n}z_1) \cdots (z - \rho^{1/n}z_{n-1})$$

and

$$z^n + \rho = (z - \rho^{1/n}\zeta_0)(z - \rho^{1/n}\zeta_1) \cdots (z - \rho^{1/n}\zeta_{n-1}).$$

43. Use (e) of Exercise 42 to find a fundamental set of solutions of the given equation.

(a)  $y''' - y = 0$

(b)  $y''' + y = 0$

(c)  $y^{(4)} + 64y = 0$

(d)  $y^{(6)} - y = 0$

(e)  $y^{(6)} + 64y = 0$

(f)  $[(D-1)^6 - 1]y = 0$

(g)  $y^{(5)} + y^{(4)} + y''' + y'' + y' + y = 0$

44. An equation of the form

$$a_0x^n y^{(n)} + a_1x^{n-1}y^{(n-1)} + \cdots + a_{n-1}xy' + a_ny = 0, \quad x > 0, \tag{A}$$

where  $a_0, a_1, \dots, a_n$  are constants, is an *Euler* or *equidimensional* equation.

Show that if

$$x = e^t \quad \text{and} \quad Y(t) = y(x(t)), \tag{B}$$

then

$$\begin{aligned} x \frac{dy}{dx} &= \frac{dY}{dt} \\ x^2 \frac{d^2y}{dx^2} &= \frac{d^2Y}{dt^2} - \frac{dY}{dt} \\ x^3 \frac{d^3y}{dx^3} &= \frac{d^3Y}{dt^3} - 3 \frac{d^2Y}{dt^2} + 2 \frac{dY}{dt}. \end{aligned}$$

In general, it can be shown that if  $r$  is any integer  $\geq 2$  then

$$x^r \frac{d^r y}{dx^r} = \frac{d^r Y}{dt^r} + A_{1r} \frac{d^{r-1} Y}{dt^{r-1}} + \cdots + A_{r-1,r} \frac{dY}{dt}$$

where  $A_{1r}, \dots, A_{r-1,r}$  are integers. Use these results to show that the substitution (B) transforms (A) into a constant coefficient equation for  $Y$  as a function of  $t$ .

45. Use Exercise 44 to show that a function  $y = y(x)$  satisfies the equation

$$a_0x^3y''' + a_1x^2y'' + a_2xy' + a_3y = 0, \quad (\text{A})$$

on  $(0, \infty)$  if and only if the function  $Y(t) = y(e^t)$  satisfies

$$a_0\frac{d^3Y}{dt^3} + (a_1 - 3a_0)\frac{d^2Y}{dt^2} + (a_2 - a_1 + 2a_0)\frac{dY}{dt} + a_3Y = 0.$$

Assuming that  $a_0, a_1, a_2, a_3$  are real and  $a_0 \neq 0$ , find the possible forms for the general solution of (A).

### 9.3 UNDETERMINED COEFFICIENTS FOR HIGHER ORDER EQUATIONS

In this section we consider the constant coefficient equation

$$a_0y^{(n)} + a_1y^{(n-1)} + \cdots + a_ny = F(x), \quad (9.3.1)$$

where  $n \geq 3$  and  $F$  is a linear combination of functions of the form

$$e^{\alpha x} (p_0 + p_1x + \cdots + p_kx^k)$$

or

$$e^{\lambda x} [(p_0 + p_1x + \cdots + p_kx^k) \cos \omega x + (q_0 + q_1x + \cdots + q_kx^k) \sin \omega x].$$

From Theorem 9.1.5, the general solution of (9.3.1) is  $y = y_p + y_c$ , where  $y_p$  is a particular solution of (9.3.1) and  $y_c$  is the general solution of the complementary equation

$$a_0y^{(n)} + a_1y^{(n-1)} + \cdots + a_ny = 0.$$

In Section 9.2 we learned how to find  $y_c$ . Here we will learn how to find  $y_p$  when the forcing function has the form stated above. The procedure that we use is a generalization of the method that we used in Sections 5.4 and 5.5, and is again called *method of undetermined coefficients*. Since the underlying ideas are the same as those in Sections 5.4 and 5.5, we'll give an informal presentation based on examples.

#### Forcing Functions of the Form $e^{\alpha x} (p_0 + p_1x + \cdots + p_kx^k)$

We first consider equations of the form

$$a_0y^{(n)} + a_1y^{(n-1)} + \cdots + a_ny = e^{\alpha x} (p_0 + p_1x + \cdots + p_kx^k).$$

**Example 9.3.1** Find a particular solution of

$$y''' + 3y'' + 2y' - y = e^x(21 + 24x + 28x^2 + 5x^3). \quad (9.3.2)$$

**Solution** Substituting

$$\begin{aligned} y &= ue^x, \\ y' &= e^x(u' + u), \\ y'' &= e^x(u'' + 2u' + u), \\ y''' &= e^x(u''' + 3u'' + 3u' + u) \end{aligned}$$

into (9.3.2) and canceling  $e^x$  yields

$$(u''' + 3u'' + 3u' + u) + 3(u'' + 2u' + u) + 2(u' + u) - u = 21 + 24x + 28x^2 + 5x^3,$$

or

$$u''' + 6u'' + 11u' + 5u = 21 + 24x + 28x^2 + 5x^3. \quad (9.3.3)$$

Since the unknown  $u$  appears on the left, we can see that (9.3.3) has a particular solution of the form

$$u_p = A + Bx + Cx^2 + Dx^3.$$

Then

$$\begin{aligned} u_p' &= B + 2Cx + 3Dx^2 \\ u_p'' &= 2C + 6Dx \\ u_p''' &= 6D. \end{aligned}$$

Substituting from the last four equations into the left side of (9.3.3) yields

$$\begin{aligned} u_p''' + 6u_p'' + 11u_p' + 5u_p &= 6D + 6(2C + 6Dx) + 11(B + 2Cx + 3Dx^2) \\ &\quad + 5(A + Bx + Cx^2 + Dx^3) \\ &= (5A + 11B + 12C + 6D) + (5B + 22C + 36D)x \\ &\quad + (5C + 33D)x^2 + 5Dx^3. \end{aligned}$$

Comparing coefficients of like powers of  $x$  on the right sides of this equation and (9.3.3) shows that  $u_p$  satisfies (9.3.3) if

$$\begin{aligned} 5D &= 5 \\ 5C + 33D &= 28 \\ 5B + 22C + 36D &= 24 \\ 5A + 11B + 12C + 6D &= 21. \end{aligned}$$

Solving these equations successively yields  $D = 1$ ,  $C = -1$ ,  $B = 2$ ,  $A = 1$ . Therefore

$$u_p = 1 + 2x - x^2 + x^3$$

is a particular solution of (9.3.3), so

$$y_p = e^x u_p = e^x(1 + 2x - x^2 + x^3)$$

is a particular solution of (9.3.2) (Figure 9.3.1).

**Example 9.3.2** Find a particular solution of

$$y^{(4)} - y''' - 6y'' + 4y' + 8y = e^{2x}(4 + 19x + 6x^2). \quad (9.3.4)$$

**Solution** Substituting

$$\begin{aligned} y &= ue^{2x}, \\ y' &= e^{2x}(u' + 2u), \\ y'' &= e^{2x}(u'' + 4u' + 4u), \\ y''' &= e^{2x}(u''' + 6u'' + 12u' + 8u), \\ y^{(4)} &= e^{2x}(u^{(4)} + 8u''' + 24u'' + 32u' + 16u) \end{aligned}$$

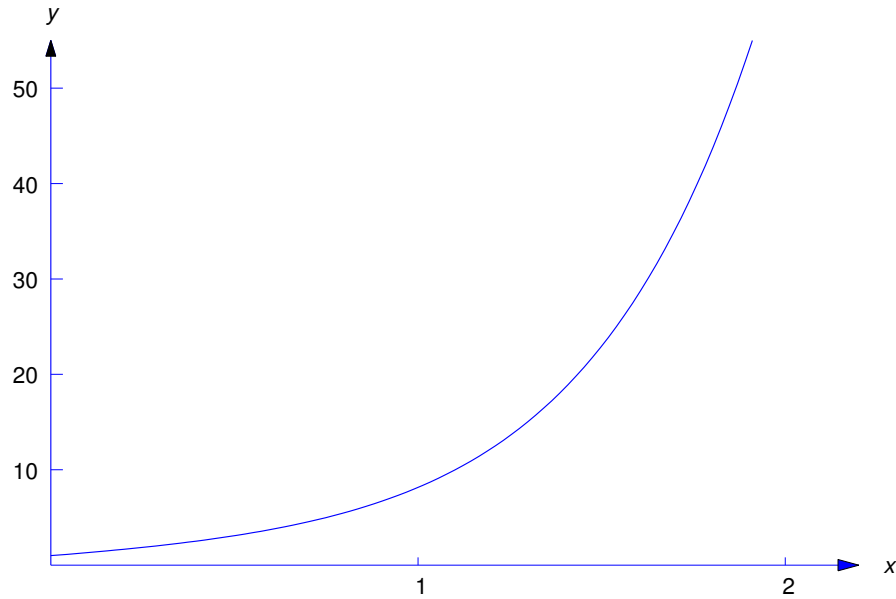
Figure 9.3.1  $y_p = e^x(1 + 2x - x^2 + x^3)$ 

into (9.3.4) and canceling  $e^{2x}$  yields

$$(u^{(4)} + 8u''' + 24u'' + 32u' + 16u) - (u''' + 6u'' + 12u' + 8u) - 6(u'' + 4u' + 4u) + 4(u' + 2u) + 8u = 4 + 19x + 6x^2,$$

or

$$u^{(4)} + 7u''' + 12u'' = 4 + 19x + 6x^2. \quad (9.3.5)$$

Since neither  $u$  nor  $u'$  appear on the left, we can see that (9.3.5) has a particular solution of the form

$$u_p = Ax^2 + Bx^3 + Cx^4. \quad (9.3.6)$$

Then

$$\begin{aligned} u_p' &= 2Ax + 3Bx^2 + 4Cx^3 \\ u_p'' &= 2A + 6Bx + 12Cx^2 \\ u_p''' &= 6B + 24Cx \\ u_p^{(4)} &= 24C. \end{aligned}$$

Substituting  $u_p''$ ,  $u_p'''$ , and  $u_p^{(4)}$  into the left side of (9.3.5) yields

$$\begin{aligned} u_p^{(4)} + 7u_p''' + 12u_p'' &= 24C + 7(6B + 24Cx) + 12(2A + 6Bx + 12Cx^2) \\ &= (24A + 42B + 24C) + (72B + 168C)x + 144Cx^2. \end{aligned}$$



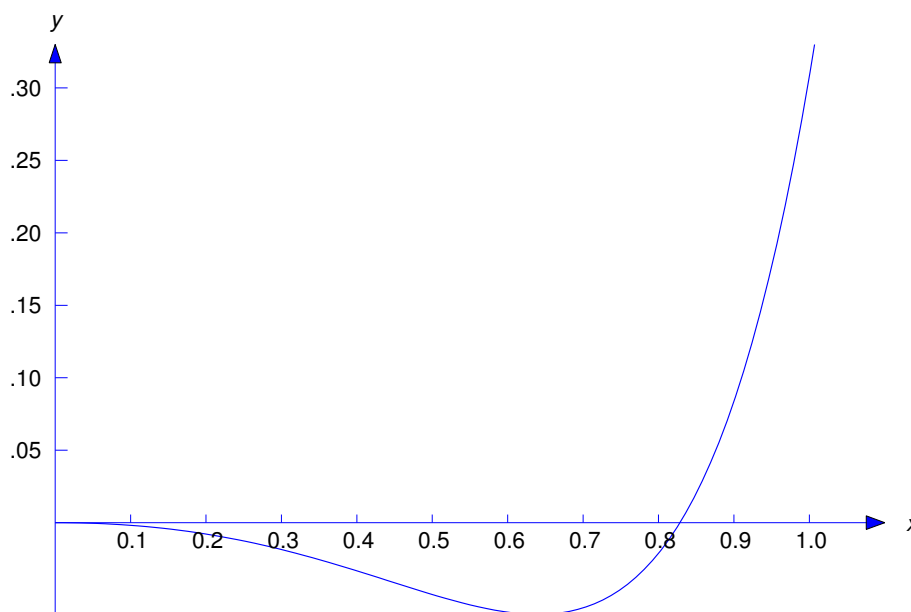

Figure 9.3.2  $y_p = \frac{x^2 e^{2x}}{24} (-4 + 4x + x^2)$

Comparing coefficients of like powers of  $x$  on the right sides of this equation and (9.3.5) shows that  $u_p$  satisfies (9.3.5) if

$$\begin{aligned} 144C &= 6 \\ 72B + 168C &= 19 \\ 24A + 42B + 24C &= 4. \end{aligned}$$

Solving these equations successively yields  $C = 1/24$ ,  $B = 1/6$ ,  $A = -1/6$ . Substituting these into (9.3.6) shows that

$$u_p = \frac{x^2}{24} (-4 + 4x + x^2)$$

is a particular solution of (9.3.5), so

$$y_p = e^{2x} u_p = \frac{x^2 e^{2x}}{24} (-4 + 4x + x^2)$$

is a particular solution of (9.3.4). (Figure 9.3.2).

### Forcing Functions of the Form $e^{\lambda x} (P(x) \cos \omega x + Q(x) \sin \omega x)$

We now consider equations of the form

$$a_0 y^{(n)} + a_1 y^{(n-1)} + \cdots + a_n y = e^{\lambda x} (P(x) \cos \omega x + Q(x) \sin \omega x),$$

where  $P$  and  $Q$  are polynomials.

**Example 9.3.3** Find a particular solution of

$$y''' + y'' - 4y' - 4y = e^x [(5 - 5x) \cos x + (2 + 5x) \sin x]. \quad (9.3.7)$$

**Solution** Substituting

$$\begin{aligned}y &= ue^x, \\y' &= e^x(u' + u), \\y'' &= e^x(u'' + 2u' + u), \\y''' &= e^x(u''' + 3u'' + 3u' + u)\end{aligned}$$

into (9.3.7) and canceling  $e^x$  yields

$$(u''' + 3u'' + 3u' + u) + (u'' + 2u' + u) - 4(u' + u) - 4u = (5 - 5x) \cos x + (2 + 5x) \sin x,$$

or

$$u''' + 4u'' + u' - 6u = (5 - 5x) \cos x + (2 + 5x) \sin x. \quad (9.3.8)$$

Since  $\cos x$  and  $\sin x$  are not solutions of the complementary equation

$$u''' + 4u'' + u' - 6u = 0,$$

a theorem analogous to Theorem 5.5.1 implies that (9.3.8) has a particular solution of the form

$$u_p = (A_0 + A_1x) \cos x + (B_0 + B_1x) \sin x. \quad (9.3.9)$$

Then

$$\begin{aligned}u_p' &= (A_1 + B_0 + B_1x) \cos x + (B_1 - A_0 - A_1x) \sin x, \\u_p'' &= (2B_1 - A_0 - A_1x) \cos x - (2A_1 + B_0 + B_1x) \sin x, \\u_p''' &= -(3A_1 + B_0 + B_1x) \cos x - (3B_1 - A_0 - A_1x) \sin x,\end{aligned}$$

so

$$\begin{aligned}u_p''' + 4u_p'' + u_p' - 6u_p &= -[10A_0 + 2A_1 - 8B_1 + 10A_1x] \cos x \\&\quad - [10B_0 + 2B_1 + 8A_1 + 10B_1x] \sin x.\end{aligned}$$

Comparing the coefficients of  $x \cos x$ ,  $x \sin x$ ,  $\cos x$ , and  $\sin x$  here with the corresponding coefficients in (9.3.8) shows that  $u_p$  is a solution of (9.3.8) if

$$\begin{aligned}-10A_1 &= -5 \\-10B_1 &= 5 \\-10A_0 - 2A_1 + 8B_1 &= 5 \\-10B_0 - 2B_1 - 8A_1 &= 2.\end{aligned}$$

Solving the first two equations yields  $A_1 = 1/2$ ,  $B_1 = -1/2$ . Substituting these into the last two equations yields

$$\begin{aligned}-10A_0 &= 5 + 2A_1 - 8B_1 = 10 \\-10B_0 &= 2 + 2B_1 + 8A_1 = 5,\end{aligned}$$

so  $A_0 = -1$ ,  $B_0 = -1/2$ . Substituting  $A_0 = -1$ ,  $A_1 = 1/2$ ,  $B_0 = -1/2$ ,  $B_1 = -1/2$  into (9.3.9) shows that

$$u_p = -\frac{1}{2} [(2 - x) \cos x + (1 + x) \sin x]$$

is a particular solution of (9.3.8), so

$$y_p = e^x u_p = -\frac{e^x}{2} [(2 - x) \cos x + (1 + x) \sin x]$$

is a particular solution of (9.3.7) (Figure 9.3.3).

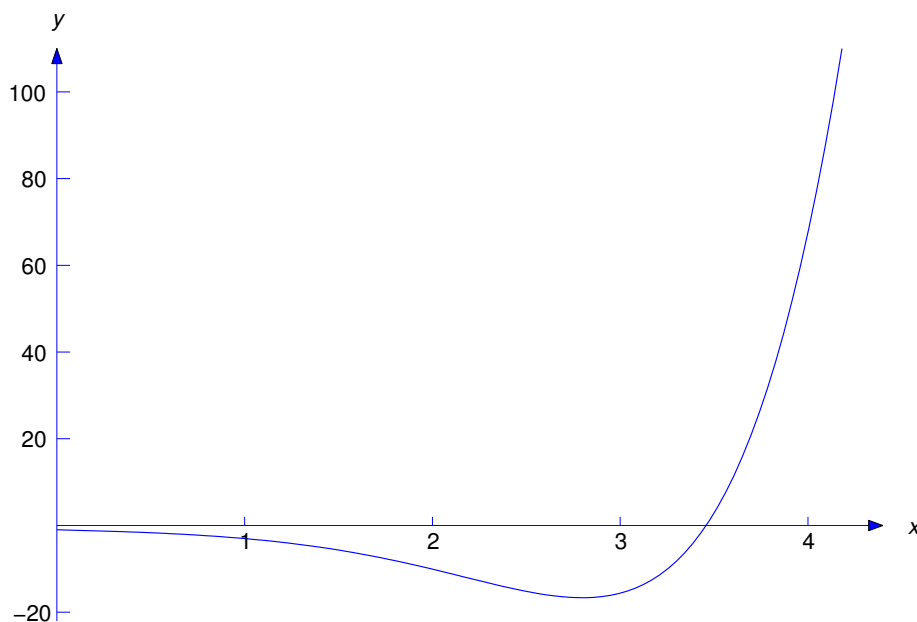

Figure 9.3.3  $y_p = e^x u_p = -\frac{e^x}{2} [(2-x)\cos x + (1+x)\sin x]$

**Example 9.3.4** Find a particular solution of

$$y''' + 4y'' + 6y' + 4y = e^{-x} [(1-6x)\cos x - (3+2x)\sin x]. \quad (9.3.10)$$

**Solution** Substituting

$$\begin{aligned} y &= ue^{-x}, \\ y' &= e^{-x}(u' - u), \\ y'' &= e^{-x}(u'' - 2u' + u), \\ y''' &= e^{-x}(u''' - 3u'' + 3u' - u) \end{aligned}$$

into (9.3.10) and canceling  $e^{-x}$  yields

$$(u''' - 3u'' + 3u' - u) + 4(u'' - 2u' + u) + 6(u' - u) + 4u = (1-6x)\cos x - (3+2x)\sin x,$$

or

$$u''' + u'' + u' + u = (1-6x)\cos x - (3+2x)\sin x. \quad (9.3.11)$$

Since  $\cos x$  and  $\sin x$  are solutions of the complementary equation

$$u''' + u'' + u' + u = 0,$$

a theorem analogous to Theorem 5.5.1 implies that (9.3.11) has a particular solution of the form

$$u_p = (A_0x + A_1x^2)\cos x + (B_0x + B_1x^2)\sin x. \quad (9.3.12)$$

Then

$$\begin{aligned} u_p' &= [A_0 + (2A_1 + B_0)x + B_1x^2] \cos x + [B_0 + (2B_1 - A_0)x - A_1x^2] \sin x, \\ u_p'' &= [2A_1 + 2B_0 - (A_0 - 4B_1)x - A_1x^2] \cos x \\ &\quad + [2B_1 - 2A_0 - (B_0 + 4A_1)x - B_1x^2] \sin x, \\ u_p''' &= [-3A_0 - 6B_1 + (6A_1 + B_0)x + B_1x^2] \cos x \\ &\quad - [3B_0 + 6A_1 + (6B_1 - A_0)x - A_1x^2] \sin x, \end{aligned}$$

so

$$\begin{aligned} u_p''' + u_p'' + u_p' + u_p &= [-2A_0 - 2B_0 - 2A_1 - 6B_1 + (4A_1 - 4B_1)x] \cos x \\ &\quad - [2B_0 + 2A_0 - 2B_1 + 6A_1 + (4B_1 + 4A_1)x] \sin x. \end{aligned}$$

Comparing the coefficients of  $x \cos x$ ,  $x \sin x$ ,  $\cos x$ , and  $\sin x$  here with the corresponding coefficients in (9.3.11) shows that  $u_p$  is a solution of (9.3.11) if

$$\begin{aligned} -4A_1 + 4B_1 &= -6 \\ -4A_1 - 4B_1 &= -2 \\ -2A_0 + 2B_0 + 2A_1 + 6B_1 &= 1 \\ -2A_0 - 2B_0 - 6A_1 + 2B_1 &= -3. \end{aligned}$$

Solving the first two equations yields  $A_1 = 1$ ,  $B_1 = -1/2$ . Substituting these into the last two equations yields

$$\begin{aligned} -2A_0 + 2B_0 &= 1 - 2A_1 - 6B_1 = 2 \\ -2A_0 - 2B_0 &= -3 + 6A_1 - 2B_1 = 4, \end{aligned}$$

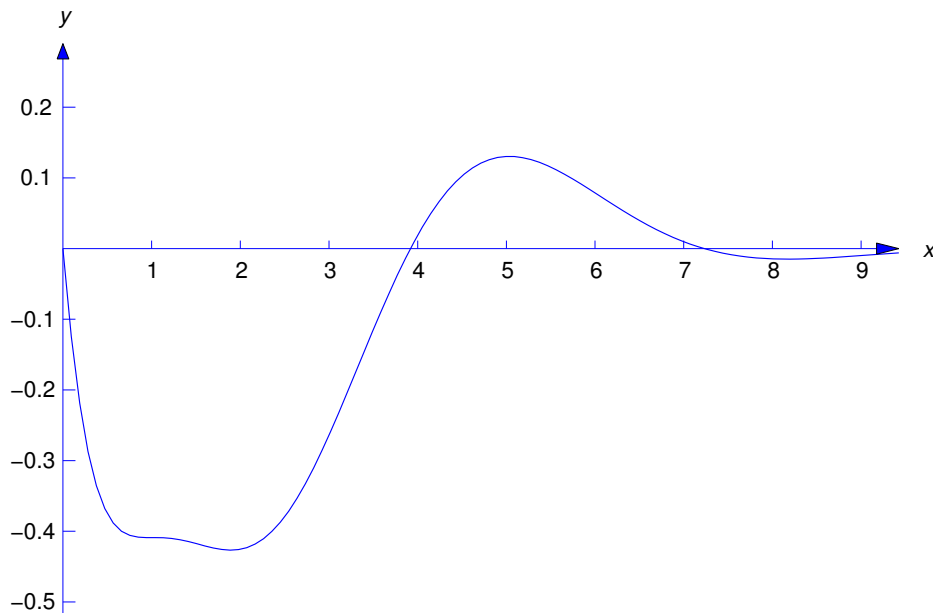

Figure 9.3.4  $y_p = -\frac{x e^{-x}}{2} [(3 - 2x) \cos x + (1 + x) \sin x]$

so  $A_0 = -3/2$  and  $B_0 = -1/2$ . Substituting  $A_0 = -3/2$ ,  $A_1 = 1$ ,  $B_0 = -1/2$ ,  $B_1 = -1/2$  into (9.3.12) shows that

$$u_p = -\frac{x}{2} [(3 - 2x) \cos x + (1 + x) \sin x]$$

is a particular solution of (9.3.11), so

$$y_p = e^{-x} u_p = -\frac{x e^{-x}}{2} [(3 - 2x) \cos x + (1 + x) \sin x]$$

(Figure 9.3.4) is a particular solution of (9.3.10).

### 9.3 Exercises

---

In Exercises 1–59 find a particular solution.

1.  $y''' - 6y'' + 11y' - 6y = -e^{-x}(4 + 76x - 24x^2)$
2.  $y''' - 2y'' - 5y' + 6y = e^{-3x}(32 - 23x + 6x^2)$
3.  $4y''' + 8y'' - y' - 2y = -e^x(4 + 45x + 9x^2)$
4.  $y''' + 3y'' - y' - 3y = e^{-2x}(2 - 17x + 3x^2)$
5.  $y''' + 3y'' - y' - 3y = e^x(-1 + 2x + 24x^2 + 16x^3)$
6.  $y''' + y'' - 2y = e^x(14 + 34x + 15x^2)$
7.  $4y''' + 8y'' - y' - 2y = -e^{-2x}(1 - 15x)$
8.  $y''' - y'' - y' + y = e^x(7 + 6x)$
9.  $2y''' - 7y'' + 4y' + 4y = e^{2x}(17 + 30x)$
10.  $y''' - 5y'' + 3y' + 9y = 2e^{3x}(11 - 24x^2)$
11.  $y''' - 7y'' + 8y' + 16y = 2e^{4x}(13 + 15x)$
12.  $8y''' - 12y'' + 6y' - y = e^{x/2}(1 + 4x)$
13.  $y^{(4)} + 3y''' - 3y'' - 7y' + 6y = -e^{-x}(12 + 8x - 8x^2)$
14.  $y^{(4)} + 3y''' + y'' - 3y' - 2y = -3e^{2x}(11 + 12x)$
15.  $y^{(4)} + 8y''' + 24y'' + 32y' = -16e^{-2x}(1 + x + x^2 - x^3)$
16.  $4y^{(4)} - 11y''' - 9y'' - 2y = -e^x(1 - 6x)$
17.  $y^{(4)} - 2y''' + 3y' - y = e^x(3 + 4x + x^2)$
18.  $y^{(4)} - 4y''' + 6y'' - 4y' + 2y = e^{2x}(24 + x + x^4)$
19.  $2y^{(4)} + 5y''' - 5y'' - 2y = 18e^x(5 + 2x)$
20.  $y^{(4)} + y''' - 2y'' - 6y' - 4y = -e^{2x}(4 + 28x + 15x^2)$
21.  $2y^{(4)} + y''' - 2y'' - y = 3e^{-x/2}(1 - 6x)$
22.  $y^{(4)} - 5y'' + 4y = e^x(3 + x - 3x^2)$
23.  $y^{(4)} - 2y''' - 3y'' + 4y' + 4y = e^{2x}(13 + 33x + 18x^2)$
24.  $y^{(4)} - 3y''' + 4y' = e^{2x}(15 + 26x + 12x^2)$
25.  $y^{(4)} - 2y''' + 2y' - y = e^x(1 + x)$
26.  $2y^{(4)} - 5y''' + 3y'' + y' - y = e^x(11 + 12x)$

27.  $y^{(4)} + 3y''' + 3y'' + y' = e^{-x}(5 - 24x + 10x^2)$
28.  $y^{(4)} - 7y''' + 18y'' - 20y' + 8y = e^{2x}(3 - 8x - 5x^2)$
29.  $y''' - y'' - 4y' + 4y = e^{-x}[(16 + 10x)\cos x + (30 - 10x)\sin x]$
30.  $y''' + y'' - 4y' - 4y = e^{-x}[(1 - 22x)\cos 2x - (1 + 6x)\sin 2x]$
31.  $y''' - y'' + 2y' - 2y = e^{2x}[(27 + 5x - x^2)\cos x + (2 + 13x + 9x^2)\sin x]$
32.  $y''' - 2y'' + y' - 2y = -e^x[(9 - 5x + 4x^2)\cos 2x - (6 - 5x - 3x^2)\sin 2x]$
33.  $y''' + 3y'' + 4y' + 12y = 8\cos 2x - 16\sin 2x$
34.  $y''' - y'' + 2y = e^x[(20 + 4x)\cos x - (12 + 12x)\sin x]$
35.  $y''' - 7y'' + 20y' - 24y = -e^{2x}[(13 - 8x)\cos 2x - (8 - 4x)\sin 2x]$
36.  $y''' - 6y'' + 18y' = -e^{3x}[(2 - 3x)\cos 3x - (3 + 3x)\sin 3x]$
37.  $y^{(4)} + 2y''' - 2y'' - 8y' - 8y = e^x(8\cos x + 16\sin x)$
38.  $y^{(4)} - 3y''' + 2y'' + 2y' - 4y = e^x(2\cos 2x - \sin 2x)$
39.  $y^{(4)} - 8y''' + 24y'' - 32y' + 15y = e^{2x}(15x\cos 2x + 32\sin 2x)$
40.  $y^{(4)} + 6y''' + 13y'' + 12y' + 4y = e^{-x}[(4 - x)\cos x - (5 + x)\sin x]$
41.  $y^{(4)} + 3y''' + 2y'' - 2y' - 4y = -e^{-x}(\cos x - \sin x)$
42.  $y^{(4)} - 5y''' + 13y'' - 19y' + 10y = e^x(\cos 2x + \sin 2x)$
43.  $y^{(4)} + 8y''' + 32y'' + 64y' + 39y = e^{-2x}[(4 - 15x)\cos 3x - (4 + 15x)\sin 3x]$
44.  $y^{(4)} - 5y''' + 13y'' - 19y' + 10y = e^x[(7 + 8x)\cos 2x + (8 - 4x)\sin 2x]$
45.  $y^{(4)} + 4y''' + 8y'' + 8y' + 4y = -2e^{-x}(\cos x - 2\sin x)$
46.  $y^{(4)} - 8y''' + 32y'' - 64y' + 64y = e^{2x}(\cos 2x - \sin 2x)$
47.  $y^{(4)} - 8y''' + 26y'' - 40y' + 25y = e^{2x}[3\cos x - (1 + 3x)\sin x]$
48.  $y''' - 4y'' + 5y' - 2y = e^{2x} - 4e^x - 2\cos x + 4\sin x$
49.  $y''' - y'' + y' - y = 5e^{2x} + 2e^x - 4\cos x + 4\sin x$
50.  $y''' - y' = -2(1 + x) + 4e^x - 6e^{-x} + 96e^{3x}$
51.  $y''' - 4y'' + 9y' - 10y = 10e^{2x} + 20e^x \sin 2x - 10$
52.  $y''' + 3y'' + 3y' + y = 12e^{-x} + 9\cos 2x - 13\sin 2x$
53.  $y''' + y'' - y' - y = 4e^{-x}(1 - 6x) - 2x\cos x + 2(1 + x)\sin x$
54.  $y^{(4)} - 5y''' + 4y = -12e^x + 6e^{-x} + 10\cos x$
55.  $y^{(4)} - 4y''' + 11y'' - 14y' + 10y = -e^x(\sin x + 2\cos 2x)$
56.  $y^{(4)} + 2y''' - 3y'' - 4y' + 4y = 2e^x(1 + x) + e^{-2x}$
57.  $y^{(4)} + 4y = \sinh x \cos x - \cosh x \sin x$
58.  $y^{(4)} + 5y''' + 9y'' + 7y' + 2y = e^{-x}(30 + 24x) - e^{-2x}$
59.  $y^{(4)} - 4y''' + 7y'' - 6y' + 2y = e^x(12x - 2\cos x + 2\sin x)$

In Exercises 60–68 find the general solution.

60.  $y''' - y'' - y' + y = e^{2x}(10 + 3x)$
61.  $y''' + y'' - 2y = -e^{3x}(9 + 67x + 17x^2)$

62.  $y''' - 6y'' + 11y' - 6y = e^{2x}(5 - 4x - 3x^2)$   
 63.  $y''' + 2y'' + y' = -2e^{-x}(7 - 18x + 6x^2)$   
 64.  $y''' - 3y'' + 3y' - y = e^x(1 + x)$   
 65.  $y^{(4)} - 2y'' + y = -e^{-x}(4 - 9x + 3x^2)$   
 66.  $y''' + 2y'' - y' - 2y = e^{-2x}[(23 - 2x)\cos x + (8 - 9x)\sin x]$   
 67.  $y^{(4)} - 3y''' + 4y'' - 2y' = e^x[(28 + 6x)\cos 2x + (11 - 12x)\sin 2x]$   
 68.  $y^{(4)} - 4y''' + 14y'' - 20y' + 25y = e^x[(2 + 6x)\cos 2x + 3\sin 2x]$

In Exercises 69–74 solve the initial value problem and graph the solution.

69. C/G  $y''' - 2y'' - 5y' + 6y = 2e^x(1 - 6x), \quad y(0) = 2, \quad y'(0) = 7, \quad y''(0) = 9$   
 70. C/G  $y''' - y'' - y' + y = -e^{-x}(4 - 8x), \quad y(0) = 2, \quad y'(0) = 0, \quad y''(0) = 0$   
 71. C/G  $4y''' - 3y' - y = e^{-x/2}(2 - 3x), \quad y(0) = -1, \quad y'(0) = 15, \quad y''(0) = -17$   
 72. C/G  $y^{(4)} + 2y''' + 2y'' + 2y' + y = e^{-x}(20 - 12x), \quad y(0) = 3, \quad y'(0) = -4, \quad y''(0) = 7, \quad y'''(0) = -22$   
 73. C/G  $y''' + 2y'' + y' + 2y = 30\cos x - 10\sin x, \quad y(0) = 3, \quad y'(0) = -4, \quad y''(0) = 16$   
 74. C/G  $y^{(4)} - 3y''' + 5y'' - 2y' = -2e^x(\cos x - \sin x), \quad y(0) = 2, \quad y'(0) = 0, \quad y''(0) = -1, \quad y'''(0) = -5$   
 75. Prove: A function  $y$  is a solution of the constant coefficient nonhomogeneous equation

$$a_0y^{(n)} + a_1y^{(n-1)} + \cdots + a_ny = e^{\alpha x}G(x) \quad (\text{A})$$

if and only if  $y = ue^{\alpha x}$ , where  $u$  satisfies the differential equation

$$a_0u^{(n)} + \frac{p^{(n-1)}(\alpha)}{(n-1)!}u^{(n-1)} + \frac{p^{(n-2)}(\alpha)}{(n-2)!}u^{(n-2)} + \cdots + p(\alpha)u = G(x) \quad (\text{B})$$

and

$$p(r) = a_0r^n + a_1r^{n-1} + \cdots + a_n$$

is the characteristic polynomial of the complementary equation

$$a_0y^{(n)} + a_1y^{(n-1)} + \cdots + a_ny = 0.$$

76. Prove:

(a) The equation

$$\begin{aligned} a_0u^{(n)} + \frac{p^{(n-1)}(\alpha)}{(n-1)!}u^{(n-1)} + \frac{p^{(n-2)}(\alpha)}{(n-2)!}u^{(n-2)} + \cdots + p(\alpha)u \\ = (p_0 + p_1x + \cdots + p_kx^k)\cos \omega x \\ + (q_0 + q_1x + \cdots + q_kx^k)\sin \omega x \end{aligned} \quad (\text{A})$$

has a particular solution of the form

$$u_p = x^m(u_0 + u_1x + \cdots + u_kx^k)\cos \omega x + (v_0 + v_1x + \cdots + v_kx^k)\sin \omega x.$$

(b) If  $\lambda + i\omega$  is a zero of  $p$  with multiplicity  $m \geq 1$ , then (A) can be written as

$$a(u'' + \omega^2 u) = (p_0 + p_1 x + \cdots + p_k x^k) \cos \omega x + (q_0 + q_1 x + \cdots + q_k x^k) \sin \omega x,$$

which has a particular solution of the form

$$u_p = U(x) \cos \omega x + V(x) \sin \omega x,$$

where

$$U(x) = u_0 x + u_1 x^2 + \cdots + u_k x^{k+1}, \quad V(x) = v_0 x + v_1 x^2 + \cdots + v_k x^{k+1}$$

and

$$a(U''(x) + 2\omega V'(x)) = p_0 + p_1 x + \cdots + p_k x^k$$

$$a(V''(x) - 2\omega U'(x)) = q_0 + q_1 x + \cdots + q_k x^k.$$

## 9.4 VARIATION OF PARAMETERS FOR HIGHER ORDER EQUATIONS

### Derivation of the method

We assume throughout this section that the nonhomogeneous linear equation

$$P_0(x)y^{(n)} + P_1(x)y^{(n-1)} + \cdots + P_n(x)y = F(x) \quad (9.4.1)$$

is normal on an interval  $(a, b)$ . We'll abbreviate this equation as  $Ly = F$ , where

$$Ly = P_0(x)y^{(n)} + P_1(x)y^{(n-1)} + \cdots + P_n(x)y.$$

When we speak of solutions of this equation and its complementary equation  $Ly = 0$ , we mean solutions on  $(a, b)$ . We'll show how to use the method of variation of parameters to find a particular solution of  $Ly = F$ , provided that we know a fundamental set of solutions  $\{y_1, y_2, \dots, y_n\}$  of  $Ly = 0$ .

We seek a particular solution of  $Ly = F$  in the form

$$y_p = u_1 y_1 + u_2 y_2 + \cdots + u_n y_n \quad (9.4.2)$$

where  $\{y_1, y_2, \dots, y_n\}$  is a known fundamental set of solutions of the complementary equation

$$P_0(x)y^{(n)} + P_1(x)y^{(n-1)} + \cdots + P_n(x)y = 0$$

and  $u_1, u_2, \dots, u_n$  are functions to be determined. We begin by imposing the following  $n - 1$  conditions on  $u_1, u_2, \dots, u_n$ :

$$\begin{aligned} u'_1 y_1 + u'_2 y_2 + \cdots + u'_n y_n &= 0 \\ u'_1 y'_1 + u'_2 y'_2 + \cdots + u'_n y'_n &= 0 \\ &\vdots \\ u'_1 y_1^{(n-2)} + u'_2 y_2^{(n-2)} + \cdots + u'_n y_n^{(n-2)} &= 0. \end{aligned} \quad (9.4.3)$$

These conditions lead to simple formulas for the first  $n - 1$  derivatives of  $y_p$ :

$$y_p^{(r)} = u_1 y_1^{(r)} + u_2 y_2^{(r)} + \cdots + u_n y_n^{(r)}, \quad 0 \leq r \leq n - 1. \quad (9.4.4)$$



These formulas are easy to remember, since they look as though we obtained them by differentiating (9.4.2)  $n - 1$  times while treating  $u_1, u_2, \dots, u_n$  as constants. To see that (9.4.3) implies (9.4.4), we first differentiate (9.4.2) to obtain

$$y'_p = u_1 y'_1 + u_2 y'_2 + \cdots + u_n y'_n + u'_1 y_1 + u'_2 y_2 + \cdots + u'_n y_n,$$

which reduces to

$$y'_p = u_1 y'_1 + u_2 y'_2 + \cdots + u_n y'_n$$

because of the first equation in (9.4.3). Differentiating this yields

$$y''_p = u_1 y''_1 + u_2 y''_2 + \cdots + u_n y''_n + u'_1 y'_1 + u'_2 y'_2 + \cdots + u'_n y'_n,$$

which reduces to

$$y''_p = u_1 y''_1 + u_2 y''_2 + \cdots + u_n y''_n$$

because of the second equation in (9.4.3). Continuing in this way yields (9.4.4).

The last equation in (9.4.4) is

$$y_p^{(n-1)} = u_1 y_1^{(n-1)} + u_2 y_2^{(n-1)} + \cdots + u_n y_n^{(n-1)}.$$

Differentiating this yields

$$y_p^{(n)} = u_1 y_1^{(n)} + u_2 y_2^{(n)} + \cdots + u_n y_n^{(n)} + u'_1 y_1^{(n-1)} + u'_2 y_2^{(n-1)} + \cdots + u'_n y_n^{(n-1)}.$$

Substituting this and (9.4.4) into (9.4.1) yields

$$u_1 L y_1 + u_2 L y_2 + \cdots + u_n L y_n + P_0(x) \left( u'_1 y_1^{(n-1)} + u'_2 y_2^{(n-1)} + \cdots + u'_n y_n^{(n-1)} \right) = F(x).$$

Since  $L y_i = 0$  ( $1 \leq i \leq n$ ), this reduces to

$$u'_1 y_1^{(n-1)} + u'_2 y_2^{(n-1)} + \cdots + u'_n y_n^{(n-1)} = \frac{F(x)}{P_0(x)}.$$

Combining this equation with (9.4.3) shows that

$$y_p = u_1 y_1 + u_2 y_2 + \cdots + u_n y_n$$

is a solution of (9.4.1) if

$$\begin{aligned} u'_1 y_1 + u'_2 y_2 + \cdots + u'_n y_n &= 0 \\ u'_1 y'_1 + u'_2 y'_2 + \cdots + u'_n y'_n &= 0 \\ &\vdots \\ u'_1 y_1^{(n-2)} + u'_2 y_2^{(n-2)} + \cdots + u'_n y_n^{(n-2)} &= 0 \\ u'_1 y_1^{(n-1)} + u'_2 y_2^{(n-1)} + \cdots + u'_n y_n^{(n-1)} &= F/P_0, \end{aligned}$$

which can be written in matrix form as

$$\begin{bmatrix} y_1 & y_2 & \cdots & y_n \\ y'_1 & y'_2 & \cdots & y'_n \\ \vdots & \vdots & \ddots & \vdots \\ y_1^{(n-2)} & y_2^{(n-2)} & \cdots & y_n^{(n-2)} \\ y_1^{(n-1)} & y_2^{(n-1)} & \cdots & y_n^{(n-1)} \end{bmatrix} \begin{bmatrix} u'_1 \\ u'_2 \\ \vdots \\ u'_{n-1} \\ u'_n \end{bmatrix} = \begin{bmatrix} 0 \\ 0 \\ \vdots \\ 0 \\ F/P_0 \end{bmatrix}. \quad (9.4.5)$$

The determinant of this system is the Wronskian  $W$  of the fundamental set of solutions  $\{y_1, y_2, \dots, y_n\}$ , which has no zeros on  $(a, b)$ , by Theorem 9.1.4. Solving (9.4.5) by Cramer's rule yields

$$u'_j = (-1)^{n-j} \frac{FW_j}{P_0W}, \quad 1 \leq j \leq n, \quad (9.4.6)$$

where  $W_j$  is the Wronskian of the set of functions obtained by deleting  $y_j$  from  $\{y_1, y_2, \dots, y_n\}$  and keeping the remaining functions in the same order. Equivalently,  $W_j$  is the determinant obtained by deleting the last row and  $j$ -th column of  $W$ .

Having obtained  $u'_1, u'_2, \dots, u'_n$ , we can integrate to obtain  $u_1, u_2, \dots, u_n$ . As in Section 5.7, we take the constants of integration to be zero, and we drop any linear combination of  $\{y_1, y_2, \dots, y_n\}$  that may appear in  $y_p$ .

**REMARK:** For efficiency, it's best to compute  $W_1, W_2, \dots, W_n$  first, and then compute  $W$  by expanding in cofactors of the last row; thus,

$$W = \sum_{j=1}^n (-1)^{n-j} y_j^{(n-1)} W_j.$$

### Third Order Equations

If  $n = 3$ , then

$$W = \begin{vmatrix} y_1 & y_2 & y_3 \\ y'_1 & y'_2 & y'_3 \\ y''_1 & y''_2 & y''_3 \end{vmatrix}.$$

Therefore

$$W_1 = \begin{vmatrix} y_2 & y_3 \\ y'_2 & y'_3 \end{vmatrix}, \quad W_2 = \begin{vmatrix} y_1 & y_3 \\ y'_1 & y'_3 \end{vmatrix}, \quad W_3 = \begin{vmatrix} y_1 & y_2 \\ y'_1 & y'_2 \end{vmatrix},$$

and (9.4.6) becomes

$$u'_1 = \frac{FW_1}{P_0W}, \quad u'_2 = -\frac{FW_2}{P_0W}, \quad u'_3 = \frac{FW_3}{P_0W}. \quad (9.4.7)$$

**Example 9.4.1** Find a particular solution of

$$xy''' - y'' - xy' + y = 8x^2e^x, \quad (9.4.8)$$

given that  $y_1 = x$ ,  $y_2 = e^x$ , and  $y_3 = e^{-x}$  form a fundamental set of solutions of the complementary equation. Then find the general solution of (9.4.8).

**Solution** We seek a particular solution of (9.4.8) of the form

$$y_p = u_1x + u_2e^x + u_3e^{-x}.$$

The Wronskian of  $\{y_1, y_2, y_3\}$  is

$$W(x) = \begin{vmatrix} x & e^x & e^{-x} \\ 1 & e^x & -e^{-x} \\ 0 & e^x & e^{-x} \end{vmatrix},$$

so

$$\begin{aligned} W_1 &= \begin{vmatrix} e^x & e^{-x} \\ e^x & -e^{-x} \end{vmatrix} = -2, \\ W_2 &= \begin{vmatrix} x & e^{-x} \\ 1 & -e^{-x} \end{vmatrix} = -e^{-x}(x+1), \\ W_3 &= \begin{vmatrix} x & e^x \\ 1 & e^x \end{vmatrix} = e^x(x-1). \end{aligned}$$

Expanding  $W$  by cofactors of the last row yields

$$W = 0W_1 - e^xW_2 + e^{-x}W_3 = 0(-2) - e^x(-e^{-x}(x+1)) + e^{-x}e^x(x-1) = 2x.$$

Since  $F(x) = 8x^2e^x$  and  $P_0(x) = x$ ,

$$\frac{F}{P_0W} = \frac{8x^2e^x}{x \cdot 2x} = 4e^x.$$

Therefore, from (9.4.7)

$$\begin{aligned} u_1' &= 4e^xW_1 = 4e^x(-2) = -8e^x, \\ u_2' &= -4e^xW_2 = -4e^x(-e^{-x}(x+1)) = 4(x+1), \\ u_3' &= 4e^xW_3 = 4e^x(e^x(x-1)) = 4e^{2x}(x-1). \end{aligned}$$

Integrating and taking the constants of integration to be zero yields

$$u_1 = -8e^x, \quad u_2 = 2(x+1)^2, \quad u_3 = e^{2x}(2x-3).$$

Hence,

$$\begin{aligned} y_p &= u_1y_1 + u_2y_2 + u_3y_3 \\ &= (-8e^x)x + e^x(2(x+1)^2) + e^{-x}(e^{2x}(2x-3)) \\ &= e^x(2x^2 - 2x - 1). \end{aligned}$$

Since  $-e^x$  is a solution of the complementary equation, we redefine

$$y_p = 2xe^x(x-1).$$

Therefore the general solution of (9.4.8) is

$$y = 2xe^x(x-1) + c_1x + c_2e^x + c_3e^{-x}.$$

#### Fourth Order Equations

If  $n = 4$ , then

$$W = \begin{vmatrix} y_1 & y_2 & y_3 & y_4 \\ y_1' & y_2' & y_3' & y_4' \\ y_1'' & y_2'' & y_3'' & y_4'' \\ y_1''' & y_2''' & y_3''' & y_4''' \end{vmatrix},$$

Therefore

$$W_1 = \begin{vmatrix} y_2 & y_3 & y_4 \\ y_2' & y_3' & y_4' \\ y_2'' & y_3'' & y_4'' \end{vmatrix}, \quad W_2 = \begin{vmatrix} y_1 & y_3 & y_4 \\ y_1' & y_3' & y_4' \\ y_1'' & y_3'' & y_4'' \end{vmatrix},$$

$$W_3 = \begin{vmatrix} y_1 & y_2 & y_4 \\ y_1' & y_2' & y_4' \\ y_1'' & y_2'' & y_4'' \end{vmatrix}, \quad W_4 = \begin{vmatrix} y_1 & y_2 & y_3 \\ y_1' & y_2' & y_3' \\ y_1'' & y_2'' & y_3'' \end{vmatrix},$$

and (9.4.6) becomes

$$u_1' = -\frac{FW_1}{P_0W}, \quad u_2' = \frac{FW_2}{P_0W}, \quad u_3' = -\frac{FW_3}{P_0W}, \quad u_4' = \frac{FW_4}{P_0W}. \quad (9.4.9)$$

**Example 9.4.2** Find a particular solution of

$$x^4y^{(4)} + 6x^3y''' + 2x^2y'' - 4xy' + 4y = 12x^2, \quad (9.4.10)$$

given that  $y_1 = x$ ,  $y_2 = x^2$ ,  $y_3 = 1/x$  and  $y_4 = 1/x^2$  form a fundamental set of solutions of the complementary equation. Then find the general solution of (9.4.10) on  $(-\infty, 0)$  and  $(0, \infty)$ .

**Solution** We seek a particular solution of (9.4.10) of the form

$$y_p = u_1x + u_2x^2 + \frac{u_3}{x} + \frac{u_4}{x^2}.$$

The Wronskian of  $\{y_1, y_2, y_3, y_4\}$  is

$$W(x) = \begin{vmatrix} x & x^2 & 1/x & -1/x^2 \\ 1 & 2x & -1/x^2 & -2/x^3 \\ 0 & 2 & 2/x^3 & 6/x^4 \\ 0 & 0 & -6/x^4 & -24/x^5 \end{vmatrix},$$

so

$$W_1 = \begin{vmatrix} x^2 & 1/x & 1/x^2 \\ 2x & -1/x^2 & -2/x^3 \\ 2 & 2/x^3 & 6/x^4 \end{vmatrix} = -\frac{12}{x^4},$$

$$W_2 = \begin{vmatrix} x & 1/x & 1/x^2 \\ 1 & -1/x^2 & -2/x^3 \\ 0 & 2/x^3 & 6/x^4 \end{vmatrix} = -\frac{6}{x^5},$$

$$W_3 = \begin{vmatrix} x & x^2 & 1/x^2 \\ 1 & 2x & -2/x^3 \\ 0 & 2 & 6/x^4 \end{vmatrix} = \frac{12}{x^2},$$

$$W_4 = \begin{vmatrix} x & x^2 & 1/x \\ 1 & 2x & -1/x^2 \\ 0 & 2 & 2/x^3 \end{vmatrix} = \frac{6}{x}.$$

Expanding  $W$  by cofactors of the last row yields

$$\begin{aligned} W &= -0W_1 + 0W_2 - \left(-\frac{6}{x^4}\right)W_3 + \left(-\frac{24}{x^5}\right)W_4 \\ &= \frac{6}{x^4} \frac{12}{x^2} - \frac{24}{x^5} \frac{6}{x} = -\frac{72}{x^6}. \end{aligned}$$

Since  $F(x) = 12x^2$  and  $P_0(x) = x^4$ ,

$$\frac{F}{P_0W} = \frac{12x^2}{x^4} \left(-\frac{x^6}{72}\right) = -\frac{x^4}{6}.$$

Therefore, from (9.4.9),

$$\begin{aligned} u_1' &= -\left(-\frac{x^4}{6}\right)W_1 = \frac{x^4}{6} \left(-\frac{12}{x^4}\right) = -2, \\ u_2' &= -\frac{x^4}{6}W_2 = -\frac{x^4}{6} \left(-\frac{6}{x^5}\right) = \frac{1}{x}, \\ u_3' &= -\left(-\frac{x^4}{6}\right)W_3 = \frac{x^4}{6} \frac{12}{x^2} = 2x^2, \\ u_4' &= -\frac{x^4}{6}W_4 = -\frac{x^4}{6} \frac{6}{x} = -x^3. \end{aligned}$$

Integrating these and taking the constants of integration to be zero yields

$$u_1 = -2x, \quad u_2 = \ln|x|, \quad u_3 = \frac{2x^3}{3}, \quad u_4 = -\frac{x^4}{4}.$$

Hence,

$$\begin{aligned} y_p &= u_1y_1 + u_2y_2 + u_3y_3 + u_4y_4 \\ &= (-2x)x + (\ln|x|)x^2 + \frac{2x^3}{3} \frac{1}{x} + \left(-\frac{x^4}{4}\right) \frac{1}{x^2} \\ &= x^2 \ln|x| - \frac{19x^2}{12}. \end{aligned}$$

Since  $-19x^2/12$  is a solution of the complementary equation, we redefine

$$y_p = x^2 \ln|x|.$$

Therefore

$$y = x^2 \ln|x| + c_1x + c_2x^2 + \frac{c_3}{x} + \frac{c_4}{x^2}$$

is the general solution of (9.4.10) on  $(-\infty, 0)$  and  $(0, \infty)$ .

## 9.4 Exercises

In Exercises 1–21 find a particular solution, given the fundamental set of solutions of the complementary equation.

1.  $x^3y''' - x^2(x+3)y'' + 2x(x+3)y' - 2(x+3)y = -4x^4; \quad \{x, x^2, xe^x\}$

2.  $y''' + 6xy'' + (6 + 12x^2)y' + (12x + 8x^3)y = x^{1/2}e^{-x^2}$ ;  $\{e^{-x^2}, xe^{-x^2}, x^2e^{-x^2}\}$
3.  $x^3y''' - 3x^2y'' + 6xy' - 6y = 2x$ ;  $\{x, x^2, x^3\}$
4.  $x^2y''' + 2xy'' - (x^2 + 2)y' = 2x^2$ ;  $\{1, e^x/x, e^{-x}/x\}$
5.  $x^3y''' - 3x^2(x+1)y'' + 3x(x^2 + 2x + 2)y' - (x^3 + 3x^2 + 6x + 6)y = x^4e^{-3x}$ ;  
 $\{xe^x, x^2e^x, x^3e^x\}$
6.  $x(x^2 - 2)y''' + (x^2 - 6)y'' + x(2 - x^2)y' + (6 - x^2)y = 2(x^2 - 2)^2$ ;  $\{e^x, e^{-x}, 1/x\}$
7.  $xy''' - (x - 3)y'' - (x + 2)y' + (x - 1)y = -4e^{-x}$ ;  $\{e^x, e^x/x, e^{-x}/x\}$
8.  $4x^3y''' + 4x^2y'' - 5xy' + 2y = 30x^2$ ;  $\{\sqrt{x}, 1/\sqrt{x}, x^2\}$
9.  $x(x^2 - 1)y''' + (5x^2 + 1)y'' + 2xy' - 2y = 12x^2$ ;  $\{x, 1/(x - 1), 1/(x + 1)\}$
10.  $x(1 - x)y''' + (x^2 - 3x + 3)y'' + xy' - y = 2(x - 1)^2$ ;  $\{x, 1/x, e^x/x\}$
11.  $x^3y''' + x^2y'' - 2xy' + 2y = x^2$ ;  $\{x, x^2, 1/x\}$
12.  $xy''' - y'' - xy' + y = x^2$ ;  $\{x, e^x, e^{-x}\}$
13.  $xy^{(4)} + 4y''' = 6 \ln|x|$ ;  $\{1, x, x^2, 1/x\}$
14.  $16x^4y^{(4)} + 96x^3y''' + 72x^2y'' - 24xy' + 9y = 96x^{5/2}$ ;  $\{\sqrt{x}, 1/\sqrt{x}, x^{3/2}, x^{-3/2}\}$
15.  $x(x^2 - 6)y^{(4)} + 2(x^2 - 12)y''' + x(6 - x^2)y'' + 2(12 - x^2)y' = 2(x^2 - 6)^2$ ;  
 $\{1, 1/x, e^x, e^{-x}\}$
16.  $x^4y^{(4)} - 4x^3y''' + 12x^2y'' - 24xy' + 24y = x^4$ ;  $\{x, x^2, x^3, x^4\}$
17.  $x^4y^{(4)} - 4x^3y''' + 2x^2(6 - x^2)y'' + 4x(x^2 - 6)y' + (x^4 - 4x^2 + 24)y = 4x^5e^x$ ;  
 $\{xe^x, x^2e^x, xe^{-x}, x^2e^{-x}\}$
18.  $x^4y^{(4)} + 6x^3y''' + 2x^2y'' - 4xy' + 4y = 12x^2$ ;  $\{x, x^2, 1/x, 1/x^2\}$
19.  $xy^{(4)} + 4y''' - 2xy'' - 4y' + xy = 4e^x$ ;  $\{e^x, e^{-x}, e^x/x, e^{-x}/x\}$
20.  $xy^{(4)} + (4 - 6x)y''' + (13x - 18)y'' + (26 - 12x)y' + (4x - 12)y = 3e^x$ ;  $\{e^x, e^{2x}, e^x/x, e^{2x}/x\}$
21.  $x^4y^{(4)} - 4x^3y''' + x^2(12 - x^2)y'' + 2x(x^2 - 12)y' + 2(12 - x^2)y = 2x^5$ ;  $\{x, x^2, xe^x, xe^{-x}\}$

In Exercises 22–33 solve the initial value problem, given the fundamental set of solutions of the complementary equation. Where indicated by C/G, graph the solution.

22. C/G  $x^3y''' - 2x^2y'' + 3xy' - 3y = 4x$ ,  $y(1) = 4$ ,  $y'(1) = 4$ ,  $y''(1) = 2$ ;  $\{x, x^3, x \ln x\}$
23.  $x^3y''' - 5x^2y'' + 14xy' - 18y = x^3$ ,  $y(1) = 0$ ,  $y'(1) = 1$ ,  $y''(1) = 7$ ;  $\{x^2, x^3, x^3 \ln x\}$
24.  $(5 - 6x)y''' + (12x - 4)y'' + (6x - 23)y' + (22 - 12x)y = -(6x - 5)^2e^x$   
 $y(0) = -4$ ,  $y'(0) = -\frac{3}{2}$ ,  $y''(0) = -19$ ;  $\{e^x, e^{2x}, xe^{-x}\}$
25.  $x^3y''' - 6x^2y'' + 16xy' - 16y = 9x^4$ ,  $y(1) = 2$ ,  $y'(1) = 1$ ,  $y''(1) = 5$ ;  
 $\{x, x^4, x^4 \ln|x|\}$
26. C/G  $(x^2 - 2x + 2)y''' - x^2y'' + 2xy' - 2y = (x^2 - 2x + 2)^2$ ,  $y(0) = 0$ ,  $y'(0) = 5$ ,  
 $y''(0) = 0$ ;  $\{x, x^2, e^x\}$
27.  $x^3y''' + x^2y'' - 2xy' + 2y = x(x + 1)$ ,  $y(-1) = -6$ ,  $y'(-1) = \frac{43}{6}$ ,  $y''(-1) = -\frac{5}{2}$ ;  
 $\{x, x^2, 1/x\}$

28.  $(3x - 1)y''' - (12x - 1)y'' + 9(x + 1)y' - 9y = 2e^x(3x - 1)^2$ ,  $y(0) = \frac{3}{4}$ ,  
 $y'(0) = \frac{5}{4}$ ,  $y''(0) = \frac{1}{4}$ ;  $\{x + 1, e^x, e^{3x}\}$
29. **C/G**  $(x^2 - 2)y''' - 2xy'' + (2 - x^2)y' + 2xy = 2(x^2 - 2)^2$ ,  $y(0) = 1$ ,  $y'(0) = -5$ ,  
 $y''(0) = 5$ ;  $\{x^2, e^x, e^{-x}\}$
30. **C/G**  $x^4y^{(4)} + 3x^3y''' - x^2y'' + 2xy' - 2y = 9x^2$ ,  $y(1) = -7$ ,  $y'(1) = -11$ ,  $y''(1) = -5$ ,  
 $y'''(1) = 6$ ;  $\{x, x^2, 1/x, x \ln x\}$
31.  $(2x - 1)y^{(4)} - 4xy''' + (5 - 2x)y'' + 4xy' - 4y = 6(2x - 1)^2$ ,  $y(0) = \frac{55}{4}$ ,  $y'(0) = 0$ ,  
 $y''(0) = 13$ ,  $y'''(0) = 1$ ;  $\{x, e^x, e^{-x}, e^{2x}\}$
32.  $4x^4y^{(4)} + 24x^3y''' + 23x^2y'' - xy' + y = 6x$ ,  $y(1) = 2$ ,  $y'(1) = 0$ ,  $y''(1) = 4$ ,  $y'''(1) = -\frac{37}{4}$ ;  
 $\{x, \sqrt{x}, 1/x, 1/\sqrt{x}\}$
33.  $x^4y^{(4)} + 5x^3y''' - 3x^2y'' - 6xy' + 6y = 40x^3$ ,  $y(-1) = -1$ ,  $y'(-1) = -7$ ,  
 $y''(-1) = -1$ ,  $y'''(-1) = -31$ ;  $\{x, x^3, 1/x, 1/x^2\}$
34. Suppose the equation

$$P_0(x)y^{(n)} + P_1(x)y^{(n-1)} + \cdots + P_n(x)y = F(x) \quad (\text{A})$$

is normal on an interval  $(a, b)$ . Let  $\{y_1, y_2, \dots, y_n\}$  be a fundamental set of solutions of its complementary equation on  $(a, b)$ , let  $W$  be the Wronskian of  $\{y_1, y_2, \dots, y_n\}$ , and let  $W_j$  be the determinant obtained by deleting the last row and the  $j$ -th column of  $W$ . Suppose  $x_0$  is in  $(a, b)$ , let

$$u_j(x) = (-1)^{(n-j)} \int_{x_0}^x \frac{F(t)W_j(t)}{P_0(t)W(t)} dt, \quad 1 \leq j \leq n,$$

and define

$$y_p = u_1y_1 + u_2y_2 + \cdots + u_ny_n.$$

(a) Show that  $y_p$  is a solution of (A) and that

$$y_p^{(r)} = u_1y_1^{(r)} + u_2y_2^{(r)} + \cdots + u_ny_n^{(r)}, \quad 1 \leq r \leq n - 1,$$

and

$$y_p^{(n)} = u_1y_1^{(n)} + u_2y_2^{(n)} + \cdots + u_ny_n^{(n)} + \frac{F}{P_0}.$$

HINT: See the derivation of the method of variation of parameters at the beginning of the section.

(b) Show that  $y_p$  is the solution of the initial value problem

$$P_0(x)y^{(n)} + P_1(x)y^{(n-1)} + \cdots + P_n(x)y = F(x),$$

$$y(x_0) = 0, \quad y'(x_0) = 0, \dots, \quad y^{(n-1)}(x_0) = 0.$$

(c) Show that  $y_p$  can be written as

$$y_p(x) = \int_{x_0}^x G(x, t)F(t) dt,$$

where

$$G(x, t) = \frac{1}{P_0(t)W(t)} \begin{vmatrix} y_1(t) & y_2(t) & \cdots & y_n(t) \\ y_1'(t) & y_2'(t) & \cdots & y_n'(t) \\ \vdots & \vdots & \ddots & \vdots \\ y_1^{(n-2)}(t) & y_2^{(n-2)}(t) & \cdots & y_n^{(n-2)}(t) \\ y_1(x) & y_2(x) & \cdots & y_n(x) \end{vmatrix},$$

which is called the *Green's function* for (A).

(d) Show that

$$\frac{\partial^j G(x, t)}{\partial x^j} = \frac{1}{P_0(t)W(t)} \begin{vmatrix} y_1(t) & y_2(t) & \cdots & y_n(t) \\ y_1'(t) & y_2'(t) & \cdots & y_n'(t) \\ \vdots & \vdots & \ddots & \vdots \\ y_1^{(n-2)}(t) & y_2^{(n-2)}(t) & \cdots & y_n^{(n-2)}(t) \\ y_1^{(j)}(x) & y_2^{(j)}(x) & \cdots & y_n^{(j)}(x) \end{vmatrix}, \quad 0 \leq j \leq n.$$

(e) Show that if  $a < t < b$  then

$$\left. \frac{\partial^j G(x, t)}{\partial x^j} \right|_{x=t} = \begin{cases} 0, & 1 \leq j \leq n-2, \\ \frac{1}{P_0(t)}, & j = n-1. \end{cases}$$

(f) Show that

$$y_p^{(j)}(x) = \begin{cases} \int_{x_0}^x \frac{\partial^j G(x, t)}{\partial x^j} F(t) dt, & 1 \leq j \leq n-1, \\ \frac{F(x)}{P_0(x)} + \int_{x_0}^x \frac{\partial^{(n)} G(x, t)}{\partial x^n} F(t) dt, & j = n. \end{cases}$$

In Exercises 35–42 use the method suggested by Exercise 34 to find a particular solution in the form  $y_p = \int_{x_0}^x G(x, t)F(t) dt$ , given the indicated fundamental set of solutions. Assume that  $x$  and  $x_0$  are in an interval on which the equation is normal.

35.  $y''' + 2y' - y' - 2y = F(x); \quad \{e^x, e^{-x}, e^{-2x}\}$
36.  $x^3y''' + x^2y'' - 2xy' + 2y = F(x); \quad \{x, x^2, 1/x\}$
37.  $x^3y''' - x^2(x+3)y'' + 2x(x+3)y' - 2(x+3)y = F(x); \quad \{x, x^2, xe^x\}$
38.  $x(1-x)y''' + (x^2 - 3x + 3)y'' + xy' - y = F(x); \quad \{x, 1/x, e^x/x\}$
39.  $y^{(4)} - 5y'' + 4y = F(x); \quad \{e^x, e^{-x}, e^{2x}, e^{-2x}\}$
40.  $xy^{(4)} + 4y''' = F(x); \quad \{1, x, x^2, 1/x\}$
41.  $x^4y^{(4)} + 6x^3y''' + 2x^2y'' - 4xy' + 4y = F(x); \quad \{x, x^2, 1/x, 1/x^2\}$
42.  $xy^{(4)} - y''' - 4xy' + 4y = F(x); \quad \{1, x^2, e^{2x}, e^{-2x}\}$



# CHAPTER 10

## Linear Systems of Differential Equations

IN THIS CHAPTER we consider systems of differential equations involving more than one unknown function. Such systems arise in many physical applications.

SECTION 10.1 presents examples of physical situations that lead to systems of differential equations.

SECTION 10.2 discusses linear systems of differential equations.

SECTION 10.3 deals with the basic theory of homogeneous linear systems.

SECTIONS 10.4, 10.5, AND 10.6 present the theory of constant coefficient homogeneous systems.

SECTION 10.7 presents the method of variation of parameters for nonhomogeneous linear systems.

**10.1 INTRODUCTION TO SYSTEMS OF DIFFERENTIAL EQUATIONS**

Many physical situations are modelled by systems of  $n$  differential equations in  $n$  unknown functions, where  $n \geq 2$ . The next three examples illustrate physical problems that lead to systems of differential equations. In these examples and throughout this chapter we'll denote the independent variable by  $t$ .

**Example 10.1.1** Tanks  $T_1$  and  $T_2$  contain 100 gallons and 300 gallons of salt solutions, respectively. Salt solutions are simultaneously added to both tanks from external sources, pumped from each tank to the other, and drained from both tanks (Figure 10.1.1). A solution with 1 pound of salt per gallon is pumped into  $T_1$  from an external source at 5 gal/min, and a solution with 2 pounds of salt per gallon is pumped into  $T_2$  from an external source at 4 gal/min. The solution from  $T_1$  is pumped into  $T_2$  at 2 gal/min, and the solution from  $T_2$  is pumped into  $T_1$  at 3 gal/min.  $T_1$  is drained at 6 gal/min and  $T_2$  is drained at 3 gal/min. Let  $Q_1(t)$  and  $Q_2(t)$  be the number of pounds of salt in  $T_1$  and  $T_2$ , respectively, at time  $t > 0$ . Derive a system of differential equations for  $Q_1$  and  $Q_2$ . Assume that both mixtures are well stirred.

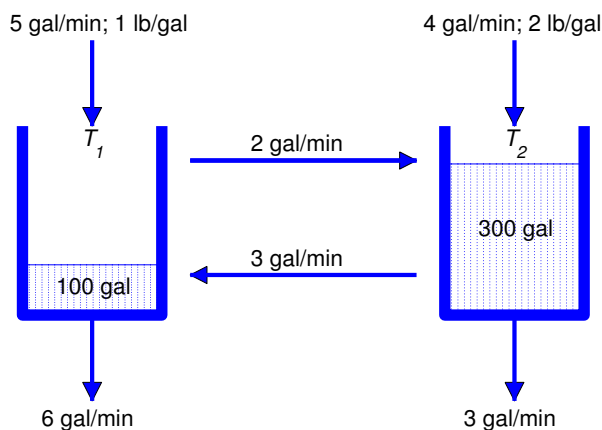

Figure 10.1.1

**Solution** As in Section 4.2, let *rate in* and *rate out* denote the rates (lb/min) at which salt enters and leaves a tank; thus,

$$Q_1' = (\text{rate in})_1 - (\text{rate out})_1,$$

$$Q_2' = (\text{rate in})_2 - (\text{rate out})_2.$$

Note that the volumes of the solutions in  $T_1$  and  $T_2$  remain constant at 100 gallons and 300 gallons, respectively.

$T_1$  receives salt from the external source at the rate of

$$(1 \text{ lb/gal}) \times (5 \text{ gal/min}) = 5 \text{ lb/min},$$

and from  $T_2$  at the rate of

$$(\text{lb/gal in } T_2) \times (3 \text{ gal/min}) = \frac{1}{300}Q_2 \times 3 = \frac{1}{100}Q_2 \text{ lb/min}.$$

Therefore

$$(\text{rate in})_1 = 5 + \frac{1}{100}Q_2. \quad (10.1.1)$$

Solution leaves  $T_1$  at the rate of 8 gal/min, since 6 gal/min are drained and 2 gal/min are pumped to  $T_2$ ; hence,

$$(\text{rate out})_1 = (\text{lb/gal in } T_1) \times (8 \text{ gal/min}) = \frac{1}{100}Q_1 \times 8 = \frac{2}{25}Q_1. \quad (10.1.2)$$

Eqns. (10.1.1) and (10.1.2) imply that

$$Q_1' = 5 + \frac{1}{100}Q_2 - \frac{2}{25}Q_1. \quad (10.1.3)$$

$T_2$  receives salt from the external source at the rate of

$$(2 \text{ lb/gal}) \times (4 \text{ gal/min}) = 8 \text{ lb/min},$$

and from  $T_1$  at the rate of

$$(\text{lb/gal in } T_1) \times (2 \text{ gal/min}) = \frac{1}{100}Q_1 \times 2 = \frac{1}{50}Q_1 \text{ lb/min}.$$

Therefore

$$(\text{rate in})_2 = 8 + \frac{1}{50}Q_1. \quad (10.1.4)$$

Solution leaves  $T_2$  at the rate of 6 gal/min, since 3 gal/min are drained and 3 gal/min are pumped to  $T_1$ ; hence,

$$(\text{rate out})_2 = (\text{lb/gal in } T_2) \times (6 \text{ gal/min}) = \frac{1}{300}Q_2 \times 6 = \frac{1}{50}Q_2. \quad (10.1.5)$$

Eqns. (10.1.4) and (10.1.5) imply that

$$Q_2' = 8 + \frac{1}{50}Q_1 - \frac{1}{50}Q_2. \quad (10.1.6)$$

We say that (10.1.3) and (10.1.6) form a *system of two first order equations in two unknowns*, and write them together as

$$\begin{aligned} Q_1' &= 5 - \frac{2}{25}Q_1 + \frac{1}{100}Q_2 \\ Q_2' &= 8 + \frac{1}{50}Q_1 - \frac{1}{50}Q_2. \quad \blacksquare \end{aligned}$$

**Example 10.1.2** A mass  $m_1$  is suspended from a rigid support on a spring  $S_1$  and a second mass  $m_2$  is suspended from the first on a spring  $S_2$  (Figure 10.1.2). The springs obey Hooke's law, with spring constants  $k_1$  and  $k_2$ . Internal friction causes the springs to exert damping forces proportional to the rates of change of their lengths, with damping constants  $c_1$  and  $c_2$ . Let  $y_1 = y_1(t)$  and  $y_2 = y_2(t)$  be the displacements of the two masses from their equilibrium positions at time  $t$ , measured positive upward. Derive a system of differential equations for  $y_1$  and  $y_2$ , assuming that the masses of the springs are negligible and that vertical external forces  $F_1$  and  $F_2$  also act on the objects.

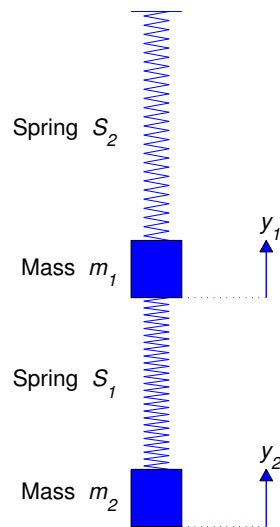

Figure 10.1.2

**Solution** In equilibrium,  $S_1$  supports both  $m_1$  and  $m_2$  and  $S_2$  supports only  $m_2$ . Therefore, if  $\Delta\ell_1$  and  $\Delta\ell_2$  are the elongations of the springs in equilibrium then

$$(m_1 + m_2)g = k_1\Delta\ell_1 \quad \text{and} \quad m_2g = k_2\Delta\ell_2. \quad (10.1.7)$$

Let  $H_1$  be the Hooke's law force acting on  $m_1$ , and let  $D_1$  be the damping force on  $m_1$ . Similarly, let  $H_2$  and  $D_2$  be the Hooke's law and damping forces acting on  $m_2$ . According to Newton's second law of motion,

$$\begin{aligned} m_1y_1'' &= -m_1g + H_1 + D_1 + F_1, \\ m_2y_2'' &= -m_2g + H_2 + D_2 + F_2. \end{aligned} \quad (10.1.8)$$

When the displacements are  $y_1$  and  $y_2$ , the change in length of  $S_1$  is  $-y_1 + \Delta\ell_1$  and the change in length of  $S_2$  is  $-y_2 + y_1 + \Delta\ell_2$ . Both springs exert Hooke's law forces on  $m_1$ , while only  $S_2$  exerts a Hooke's law force on  $m_2$ . These forces are in directions that tend to restore the springs to their natural lengths. Therefore

$$H_1 = k_1(-y_1 + \Delta\ell_1) - k_2(-y_2 + y_1 + \Delta\ell_2) \quad \text{and} \quad H_2 = k_2(-y_2 + y_1 + \Delta\ell_2). \quad (10.1.9)$$

When the velocities are  $y_1'$  and  $y_2'$ ,  $S_1$  and  $S_2$  are changing length at the rates  $-y_1'$  and  $-y_2' + y_1'$ , respectively. Both springs exert damping forces on  $m_1$ , while only  $S_2$  exerts a damping force on  $m_2$ . Since the force due to damping exerted by a spring is proportional to the rate of change of length of the spring and in a direction that opposes the change, it follows that

$$D_1 = -c_1y_1' + c_2(y_2' - y_1') \quad \text{and} \quad D_2 = -c_2(y_2' - y_1'). \quad (10.1.10)$$

From (10.1.8), (10.1.9), and (10.1.10),

$$\begin{aligned} m_1 y_1'' &= -m_1 g + k_1(-y_1 + \Delta\ell_1) - k_2(-y_2 + y_1 + \Delta\ell_2) \\ &\quad - c_1 y_1' + c_2(y_2' - y_1') + F_1 \\ &= -(m_1 g - k_1 \Delta\ell_1 + k_2 \Delta\ell_2) - k_1 y_1 + k_2(y_2 - y_1) \\ &\quad - c_1 y_1' + c_2(y_2' - y_1') + F_1 \end{aligned} \quad (10.1.11)$$

and

$$\begin{aligned} m_2 y_2'' &= -m_2 g + k_2(-y_2 + y_1 + \Delta\ell_2) - c_2(y_2' - y_1') + F_2 \\ &= -(m_2 g - k_2 \Delta\ell_2) - k_2(y_2 - y_1) - c_2(y_2' - y_1') + F_2. \end{aligned} \quad (10.1.12)$$

From (10.1.7),

$$m_1 g - k_1 \Delta\ell_1 + k_2 \Delta\ell_2 = -m_2 g + k_2 \Delta\ell_2 = 0.$$

Therefore we can rewrite (10.1.11) and (10.1.12) as

$$\begin{aligned} m_1 y_1'' &= -(c_1 + c_2)y_1' + c_2 y_2' - (k_1 + k_2)y_1 + k_2 y_2 + F_1 \\ m_2 y_2'' &= c_2 y_1' - c_2 y_2' + k_2 y_1 - k_2 y_2 + F_2. \quad \blacksquare \end{aligned}$$

**Example 10.1.3** Let  $\mathbf{X} = \mathbf{X}(t) = x(t)\mathbf{i} + y(t)\mathbf{j} + z(t)\mathbf{k}$  be the position vector at time  $t$  of an object with mass  $m$ , relative to a rectangular coordinate system with origin at Earth's center (Figure 10.1.3). According to Newton's law of gravitation, Earth's gravitational force  $\mathbf{F} = \mathbf{F}(x, y, z)$  on the object is inversely proportional to the square of the distance of the object from Earth's center, and directed toward the center; thus,

$$\mathbf{F} = \frac{K}{\|\mathbf{X}\|^2} \left( -\frac{\mathbf{X}}{\|\mathbf{X}\|} \right) = -K \frac{x\mathbf{i} + y\mathbf{j} + z\mathbf{k}}{(x^2 + y^2 + z^2)^{3/2}}, \quad (10.1.13)$$

where  $K$  is a constant. To determine  $K$ , we observe that the magnitude of  $\mathbf{F}$  is

$$\|\mathbf{F}\| = K \frac{\|\mathbf{X}\|}{\|\mathbf{X}\|^3} = \frac{K}{\|\mathbf{X}\|^2} = \frac{K}{(x^2 + y^2 + z^2)}.$$

Let  $R$  be Earth's radius. Since  $\|\mathbf{F}\| = mg$  when the object is at Earth's surface,

$$mg = \frac{K}{R^2}, \quad \text{so} \quad K = mgR^2.$$

Therefore we can rewrite (10.1.13) as

$$\mathbf{F} = -mgR^2 \frac{x\mathbf{i} + y\mathbf{j} + z\mathbf{k}}{(x^2 + y^2 + z^2)^{3/2}}.$$

Now suppose  $\mathbf{F}$  is the only force acting on the object. According to Newton's second law of motion,  $\mathbf{F} = m\mathbf{X}''$ ; that is,

$$m(x''\mathbf{i} + y''\mathbf{j} + z''\mathbf{k}) = -mgR^2 \frac{x\mathbf{i} + y\mathbf{j} + z\mathbf{k}}{(x^2 + y^2 + z^2)^{3/2}}.$$

Cancelling the common factor  $m$  and equating components on the two sides of this equation yields the system

$$\begin{aligned} x'' &= -\frac{gR^2 x}{(x^2 + y^2 + z^2)^{3/2}} \\ y'' &= -\frac{gR^2 y}{(x^2 + y^2 + z^2)^{3/2}} \\ z'' &= -\frac{gR^2 z}{(x^2 + y^2 + z^2)^{3/2}}. \end{aligned} \quad (10.1.14)$$

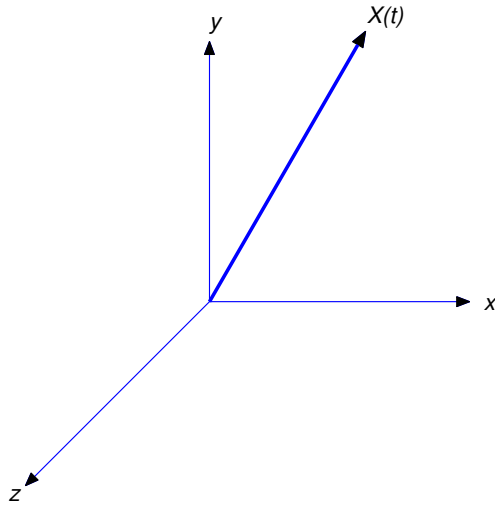

Figure 10.1.3

### Rewriting Higher Order Systems as First Order Systems

A system of the form

$$\begin{aligned} y_1' &= g_1(t, y_1, y_2, \dots, y_n) \\ y_2' &= g_2(t, y_1, y_2, \dots, y_n) \\ &\vdots \\ y_n' &= g_n(t, y_1, y_2, \dots, y_n) \end{aligned} \quad (10.1.15)$$

is called a *first order system*, since the only derivatives occurring in it are first derivatives. The derivative of each of the unknowns may depend upon the independent variable and all the unknowns, but not on the derivatives of other unknowns. When we wish to emphasize the number of unknown functions in (10.1.15) we will say that (10.1.15) is an  $n \times n$  system.

Systems involving higher order derivatives can often be reformulated as first order systems by introducing additional unknowns. The next two examples illustrate this.

**Example 10.1.4** Rewrite the system

$$\begin{aligned} m_1 y_1'' &= -(c_1 + c_2)y_1' + c_2 y_2' - (k_1 + k_2)y_1 + k_2 y_2 + F_1 \\ m_2 y_2'' &= c_2 y_1' - c_2 y_2' + k_2 y_1 - k_2 y_2 + F_2. \end{aligned} \quad (10.1.16)$$

derived in Example 10.1.2 as a system of first order equations.

**Solution** If we define  $v_1 = y_1'$  and  $v_2 = y_2'$ , then  $v_1' = y_1''$  and  $v_2' = y_2''$ , so (10.1.16) becomes

$$\begin{aligned} m_1 v_1' &= -(c_1 + c_2)v_1 + c_2 v_2 - (k_1 + k_2)y_1 + k_2 y_2 + F_1 \\ m_2 v_2' &= c_2 v_1 - c_2 v_2 + k_2 y_1 - k_2 y_2 + F_2. \end{aligned}$$

Therefore  $\{y_1, y_2, v_1, v_2\}$  satisfies the  $4 \times 4$  first order system

$$\begin{aligned} y_1' &= v_1 \\ y_2' &= v_2 \\ v_1' &= \frac{1}{m_1} [-(c_1 + c_2)v_1 + c_2v_2 - (k_1 + k_2)y_1 + k_2y_2 + F_1] \\ v_2' &= \frac{1}{m_2} [c_2v_1 - c_2v_2 + k_2y_1 - k_2y_2 + F_2]. \end{aligned} \quad (10.1.17)$$

**REMARK:** The difference in form between (10.1.15) and (10.1.17), due to the way in which the unknowns are *denoted* in the two systems, isn't important; (10.1.17) is a first order system, in that each equation in (10.1.17) expresses the first derivative of one of the unknown functions in a way that does not involve derivatives of any of the other unknowns.

**Example 10.1.5** Rewrite the system

$$\begin{aligned} x'' &= f(t, x, x', y, y', y'') \\ y''' &= g(t, x, x', y, y', y'') \end{aligned}$$

as a first order system.

**Solution** We regard  $x, x', y, y',$  and  $y''$  as unknown functions, and rename them

$$x = x_1, \quad x' = x_2, \quad y = y_1, \quad y' = y_2, \quad y'' = y_3.$$

These unknowns satisfy the system

$$\begin{aligned} x_1' &= x_2 \\ x_2' &= f(t, x_1, x_2, y_1, y_2, y_3) \\ y_1' &= y_2 \\ y_2' &= y_3 \\ y_3' &= g(t, x_1, x_2, y_1, y_2, y_3). \end{aligned}$$

### Rewriting Scalar Differential Equations as Systems

In this chapter we'll refer to differential equations involving only one unknown function as *scalar* differential equations. Scalar differential equations can be rewritten as systems of first order equations by the method illustrated in the next two examples.

**Example 10.1.6** Rewrite the equation

$$y^{(4)} + 4y''' + 6y'' + 4y' + y = 0 \quad (10.1.18)$$

as a  $4 \times 4$  first order system.

**Solution** We regard  $y, y', y'',$  and  $y'''$  as unknowns and rename them

$$y = y_1, \quad y' = y_2, \quad y'' = y_3, \quad \text{and} \quad y''' = y_4.$$

Then  $y^{(4)} = y_4'$ , so (10.1.18) can be written as

$$y_4' + 4y_4 + 6y_3 + 4y_2 + y_1 = 0.$$

Therefore  $\{y_1, y_2, y_3, y_4\}$  satisfies the system

$$\begin{aligned}y_1' &= y_2 \\y_2' &= y_3 \\y_3' &= y_4 \\y_4' &= -4y_4 - 6y_3 - 4y_2 - y_1. \blacksquare\end{aligned}$$

**Example 10.1.7** Rewrite

$$x''' = f(t, x, x', x'')$$

as a system of first order equations.

**Solution** We regard  $x$ ,  $x'$ , and  $x''$  as unknowns and rename them

$$x = y_1, \quad x' = y_2, \quad \text{and} \quad x'' = y_3.$$

Then

$$y_1' = x' = y_2, \quad y_2' = x'' = y_3, \quad \text{and} \quad y_3' = x''''.$$

Therefore  $\{y_1, y_2, y_3\}$  satisfies the first order system

$$\begin{aligned}y_1' &= y_2 \\y_2' &= y_3 \\y_3' &= f(t, y_1, y_2, y_3).\end{aligned}$$

Since systems of differential equations involving higher derivatives can be rewritten as first order systems by the method used in Examples 10.1.5–10.1.7, we'll consider only first order systems.

### Numerical Solution of Systems

The numerical methods that we studied in Chapter 3 can be extended to systems, and most differential equation software packages include programs to solve systems of equations. We won't go into detail on numerical methods for systems; however, for illustrative purposes we'll describe the Runge-Kutta method for the numerical solution of the initial value problem

$$\begin{aligned}y_1' &= g_1(t, y_1, y_2), & y_1(t_0) &= y_{10}, \\y_2' &= g_2(t, y_1, y_2), & y_2(t_0) &= y_{20}\end{aligned}$$

at equally spaced points  $t_0, t_1, \dots, t_n = b$  in an interval  $[t_0, b]$ . Thus,

$$t_i = t_0 + ih, \quad i = 0, 1, \dots, n,$$

where

$$h = \frac{b - t_0}{n}.$$

We'll denote the approximate values of  $y_1$  and  $y_2$  at these points by  $y_{10}, y_{11}, \dots, y_{1n}$  and  $y_{20}, y_{21}, \dots, y_{2n}$ .



The Runge-Kutta method computes these approximate values as follows: given  $y_{1i}$  and  $y_{2i}$ , compute

$$\begin{aligned} I_{1i} &= g_1(t_i, y_{1i}, y_{2i}), \\ J_{1i} &= g_2(t_i, y_{1i}, y_{2i}), \\ I_{2i} &= g_1\left(t_i + \frac{h}{2}, y_{1i} + \frac{h}{2}I_{1i}, y_{2i} + \frac{h}{2}J_{1i}\right), \\ J_{2i} &= g_2\left(t_i + \frac{h}{2}, y_{1i} + \frac{h}{2}I_{1i}, y_{2i} + \frac{h}{2}J_{1i}\right), \\ I_{3i} &= g_1\left(t_i + \frac{h}{2}, y_{1i} + \frac{h}{2}I_{2i}, y_{2i} + \frac{h}{2}J_{2i}\right), \\ J_{3i} &= g_2\left(t_i + \frac{h}{2}, y_{1i} + \frac{h}{2}I_{2i}, y_{2i} + \frac{h}{2}J_{2i}\right), \\ I_{4i} &= g_1(t_i + h, y_{1i} + hI_{3i}, y_{2i} + hJ_{3i}), \\ J_{4i} &= g_2(t_i + h, y_{1i} + hI_{3i}, y_{2i} + hJ_{3i}), \end{aligned}$$

and

$$\begin{aligned} y_{1,i+1} &= y_{1i} + \frac{h}{6}(I_{1i} + 2I_{2i} + 2I_{3i} + I_{4i}), \\ y_{2,i+1} &= y_{2i} + \frac{h}{6}(J_{1i} + 2J_{2i} + 2J_{3i} + J_{4i}) \end{aligned}$$

for  $i = 0, \dots, n-1$ . Under appropriate conditions on  $g_1$  and  $g_2$ , it can be shown that the global truncation error for the Runge-Kutta method is  $O(h^4)$ , as in the scalar case considered in Section 3.3.

### 10.1 Exercises

---

1. Tanks  $T_1$  and  $T_2$  contain 50 gallons and 100 gallons of salt solutions, respectively. A solution with 2 pounds of salt per gallon is pumped into  $T_1$  from an external source at 1 gal/min, and a solution with 3 pounds of salt per gallon is pumped into  $T_2$  from an external source at 2 gal/min. The solution from  $T_1$  is pumped into  $T_2$  at 3 gal/min, and the solution from  $T_2$  is pumped into  $T_1$  at 4 gal/min.  $T_1$  is drained at 2 gal/min and  $T_2$  is drained at 1 gal/min. Let  $Q_1(t)$  and  $Q_2(t)$  be the number of pounds of salt in  $T_1$  and  $T_2$ , respectively, at time  $t > 0$ . Derive a system of differential equations for  $Q_1$  and  $Q_2$ . Assume that both mixtures are well stirred.
2. Two 500 gallon tanks  $T_1$  and  $T_2$  initially contain 100 gallons each of salt solution. A solution with 2 pounds of salt per gallon is pumped into  $T_1$  from an external source at 6 gal/min, and a solution with 1 pound of salt per gallon is pumped into  $T_2$  from an external source at 5 gal/min. The solution from  $T_1$  is pumped into  $T_2$  at 2 gal/min, and the solution from  $T_2$  is pumped into  $T_1$  at 1 gal/min. Both tanks are drained at 3 gal/min. Let  $Q_1(t)$  and  $Q_2(t)$  be the number of pounds of salt in  $T_1$  and  $T_2$ , respectively, at time  $t > 0$ . Derive a system of differential equations for  $Q_1$  and  $Q_2$  that's valid until a tank is about to overflow. Assume that both mixtures are well stirred.
3. A mass  $m_1$  is suspended from a rigid support on a spring  $S_1$  with spring constant  $k_1$  and damping constant  $c_1$ . A second mass  $m_2$  is suspended from the first on a spring  $S_2$  with spring constant  $k_2$  and damping constant  $c_2$ , and a third mass  $m_3$  is suspended from the second on a spring  $S_3$  with spring constant  $k_3$  and damping constant  $c_3$ . Let  $y_1 = y_1(t)$ ,  $y_2 = y_2(t)$ , and  $y_3 = y_3(t)$  be the displacements of the three masses from their equilibrium positions at time  $t$ , measured positive upward. Derive a system of differential equations for  $y_1$ ,  $y_2$  and  $y_3$ , assuming that the masses of the springs are negligible and that vertical external forces  $F_1$ ,  $F_2$ , and  $F_3$  also act on the masses.

4. Let  $\mathbf{X} = x\mathbf{i} + y\mathbf{j} + z\mathbf{k}$  be the position vector of an object with mass  $m$ , expressed in terms of a rectangular coordinate system with origin at Earth's center (Figure 10.1.3). Derive a system of differential equations for  $x$ ,  $y$ , and  $z$ , assuming that the object moves under Earth's gravitational force (given by Newton's law of gravitation, as in Example 10.1.3) and a resistive force proportional to the speed of the object. Let  $\alpha$  be the constant of proportionality.
5. Rewrite the given system as a first order system.

$$\begin{array}{ll} \text{(a)} & \begin{array}{l} x''' = f(t, x, y, y') \\ y'' = g(t, y, y') \end{array} & \begin{array}{l} u' = f(t, u, v, v', w') \\ \text{(b)} \quad v'' = g(t, u, v, v', w) \\ w'' = h(t, u, v, v', w, w') \end{array} \end{array}$$

$$\text{(c)} \quad y''' = f(t, y, y', y'') \qquad \text{(d)} \quad y^{(4)} = f(t, y)$$

$$\text{(e)} \quad \begin{array}{l} x'' = f(t, x, y) \\ y'' = g(t, x, y) \end{array}$$

6. Rewrite the system (10.1.14) of differential equations derived in Example 10.1.3 as a first order system.
7. Formulate a version of Euler's method (Section 3.1) for the numerical solution of the initial value problem

$$\begin{array}{ll} y_1' & = g_1(t, y_1, y_2), & y_1(t_0) & = y_{10}, \\ y_2' & = g_2(t, y_1, y_2), & y_2(t_0) & = y_{20}, \end{array}$$

on an interval  $[t_0, b]$ .

8. Formulate a version of the improved Euler method (Section 3.2) for the numerical solution of the initial value problem

$$\begin{array}{ll} y_1' & = g_1(t, y_1, y_2), & y_1(t_0) & = y_{10}, \\ y_2' & = g_2(t, y_1, y_2), & y_2(t_0) & = y_{20}, \end{array}$$

on an interval  $[t_0, b]$ .

## 10.2 LINEAR SYSTEMS OF DIFFERENTIAL EQUATIONS

A first order system of differential equations that can be written in the form

$$\begin{array}{ll} y_1' & = a_{11}(t)y_1 + a_{12}(t)y_2 + \cdots + a_{1n}(t)y_n + f_1(t) \\ y_2' & = a_{21}(t)y_1 + a_{22}(t)y_2 + \cdots + a_{2n}(t)y_n + f_2(t) \\ & \vdots \\ y_n' & = a_{n1}(t)y_1 + a_{n2}(t)y_2 + \cdots + a_{nn}(t)y_n + f_n(t) \end{array} \qquad (10.2.1)$$

is called a *linear system*.

The linear system (10.2.1) can be written in matrix form as

$$\begin{bmatrix} y_1' \\ y_2' \\ \vdots \\ y_n' \end{bmatrix} = \begin{bmatrix} a_{11}(t) & a_{12}(t) & \cdots & a_{1n}(t) \\ a_{21}(t) & a_{22}(t) & \cdots & a_{2n}(t) \\ \vdots & \vdots & \ddots & \vdots \\ a_{n1}(t) & a_{n2}(t) & \cdots & a_{nn}(t) \end{bmatrix} \begin{bmatrix} y_1 \\ y_2 \\ \vdots \\ y_n \end{bmatrix} + \begin{bmatrix} f_1(t) \\ f_2(t) \\ \vdots \\ f_n(t) \end{bmatrix},$$

or more briefly as

$$\mathbf{y}' = A(t)\mathbf{y} + \mathbf{f}(t), \quad (10.2.2)$$

where

$$\mathbf{y} = \begin{bmatrix} y_1 \\ y_2 \\ \vdots \\ y_n \end{bmatrix}, \quad A(t) = \begin{bmatrix} a_{11}(t) & a_{12}(t) & \cdots & a_{1n}(t) \\ a_{21}(t) & a_{22}(t) & \cdots & a_{2n}(t) \\ \vdots & \vdots & \ddots & \vdots \\ a_{n1}(t) & a_{n2}(t) & \cdots & a_{nn}(t) \end{bmatrix}, \quad \text{and} \quad \mathbf{f}(t) = \begin{bmatrix} f_1(t) \\ f_2(t) \\ \vdots \\ f_n(t) \end{bmatrix}.$$

We call  $A$  the *coefficient matrix* of (10.2.2) and  $\mathbf{f}$  the *forcing function*. We'll say that  $A$  and  $\mathbf{f}$  are *continuous* if their entries are continuous. If  $\mathbf{f} = \mathbf{0}$ , then (10.2.2) is *homogeneous*; otherwise, (10.2.2) is *nonhomogeneous*.

An initial value problem for (10.2.2) consists of finding a solution of (10.2.2) that equals a given constant vector

$$\mathbf{k} = \begin{bmatrix} k_1 \\ k_2 \\ \vdots \\ k_n \end{bmatrix}.$$

at some initial point  $t_0$ . We write this initial value problem as

$$\mathbf{y}' = A(t)\mathbf{y} + \mathbf{f}(t), \quad \mathbf{y}(t_0) = \mathbf{k}.$$

The next theorem gives sufficient conditions for the existence of solutions of initial value problems for (10.2.2). We omit the proof.

**Theorem 10.2.1** *Suppose the coefficient matrix  $A$  and the forcing function  $\mathbf{f}$  are continuous on  $(a, b)$ , let  $t_0$  be in  $(a, b)$ , and let  $\mathbf{k}$  be an arbitrary constant  $n$ -vector. Then the initial value problem*

$$\mathbf{y}' = A(t)\mathbf{y} + \mathbf{f}(t), \quad \mathbf{y}(t_0) = \mathbf{k}$$

*has a unique solution on  $(a, b)$ .*

### Example 10.2.1

(a) Write the system

$$\begin{aligned} y_1' &= y_1 + 2y_2 + 2e^{4t} \\ y_2' &= 2y_1 + y_2 + e^{4t} \end{aligned} \quad (10.2.3)$$

in matrix form and conclude from Theorem 10.2.1 that every initial value problem for (10.2.3) has a unique solution on  $(-\infty, \infty)$ .

(b) Verify that

$$\mathbf{y} = \frac{1}{5} \begin{bmatrix} 8 \\ 7 \end{bmatrix} e^{4t} + c_1 \begin{bmatrix} 1 \\ 1 \end{bmatrix} e^{3t} + c_2 \begin{bmatrix} 1 \\ -1 \end{bmatrix} e^{-t} \quad (10.2.4)$$

is a solution of (10.2.3) for all values of the constants  $c_1$  and  $c_2$ .

(c) Find the solution of the initial value problem

$$\mathbf{y}' = \begin{bmatrix} 1 & 2 \\ 2 & 1 \end{bmatrix} \mathbf{y} + \begin{bmatrix} 2 \\ 1 \end{bmatrix} e^{4t}, \quad \mathbf{y}(0) = \frac{1}{5} \begin{bmatrix} 3 \\ 22 \end{bmatrix}. \quad (10.2.5)$$

**SOLUTION(a)** The system (10.2.3) can be written in matrix form as

$$\mathbf{y}' = \begin{bmatrix} 1 & 2 \\ 2 & 1 \end{bmatrix} \mathbf{y} + \begin{bmatrix} 2 \\ 1 \end{bmatrix} e^{4t}.$$

An initial value problem for (10.2.3) can be written as

$$\mathbf{y}' = \begin{bmatrix} 1 & 2 \\ 2 & 1 \end{bmatrix} \mathbf{y} + \begin{bmatrix} 2 \\ 1 \end{bmatrix} e^{4t}, \quad \mathbf{y}(t_0) = \begin{bmatrix} k_1 \\ k_2 \end{bmatrix}.$$

Since the coefficient matrix and the forcing function are both continuous on  $(-\infty, \infty)$ , Theorem 10.2.1 implies that this problem has a unique solution on  $(-\infty, \infty)$ .

**SOLUTION(b)** If  $\mathbf{y}$  is given by (10.2.4), then

$$\begin{aligned} A\mathbf{y} + \mathbf{f} &= \frac{1}{5} \begin{bmatrix} 1 & 2 \\ 2 & 1 \end{bmatrix} \begin{bmatrix} 8 \\ 7 \end{bmatrix} e^{4t} + c_1 \begin{bmatrix} 1 & 2 \\ 2 & 1 \end{bmatrix} \begin{bmatrix} 1 \\ 1 \end{bmatrix} e^{3t} \\ &\quad + c_2 \begin{bmatrix} 1 & 2 \\ 2 & 1 \end{bmatrix} \begin{bmatrix} 1 \\ -1 \end{bmatrix} e^{-t} + \begin{bmatrix} 2 \\ 1 \end{bmatrix} e^{4t} \\ &= \frac{1}{5} \begin{bmatrix} 22 \\ 23 \end{bmatrix} e^{4t} + c_1 \begin{bmatrix} 3 \\ 3 \end{bmatrix} e^{3t} + c_2 \begin{bmatrix} -1 \\ 1 \end{bmatrix} e^{-t} + \begin{bmatrix} 2 \\ 1 \end{bmatrix} e^{4t} \\ &= \frac{1}{5} \begin{bmatrix} 32 \\ 28 \end{bmatrix} e^{4t} + 3c_1 \begin{bmatrix} 1 \\ 1 \end{bmatrix} e^{3t} - c_2 \begin{bmatrix} 1 \\ -1 \end{bmatrix} e^{-t} = \mathbf{y}'. \end{aligned}$$

**SOLUTION(c)** We must choose  $c_1$  and  $c_2$  in (10.2.4) so that

$$\frac{1}{5} \begin{bmatrix} 8 \\ 7 \end{bmatrix} + c_1 \begin{bmatrix} 1 \\ 1 \end{bmatrix} + c_2 \begin{bmatrix} 1 \\ -1 \end{bmatrix} = \frac{1}{5} \begin{bmatrix} 3 \\ 22 \end{bmatrix},$$

which is equivalent to

$$\begin{bmatrix} 1 & 1 \\ 1 & -1 \end{bmatrix} \begin{bmatrix} c_1 \\ c_2 \end{bmatrix} = \begin{bmatrix} -1 \\ 3 \end{bmatrix}.$$

Solving this system yields  $c_1 = 1$ ,  $c_2 = -2$ , so

$$\mathbf{y} = \frac{1}{5} \begin{bmatrix} 8 \\ 7 \end{bmatrix} e^{4t} + \begin{bmatrix} 1 \\ 1 \end{bmatrix} e^{3t} - 2 \begin{bmatrix} 1 \\ -1 \end{bmatrix} e^{-t}$$

is the solution of (10.2.5).

**REMARK:** The theory of  $n \times n$  linear systems of differential equations is analogous to the theory of the scalar  $n$ -th order equation

$$P_0(t)y^{(n)} + P_1(t)y^{(n-1)} + \cdots + P_n(t)y = F(t), \quad (10.2.6)$$

as developed in Sections 9.1. For example, by rewriting (10.2.6) as an equivalent linear system it can be shown that Theorem 10.2.1 implies Theorem 9.1.1 (Exercise 12).

## 10.2 Exercises

1. Rewrite the system in matrix form and verify that the given vector function satisfies the system for any choice of the constants  $c_1$  and  $c_2$ .

$$(a) \quad \begin{aligned} y_1' &= 2y_1 + 4y_2 \\ y_2' &= 4y_1 + 2y_2; \end{aligned} \quad \mathbf{y} = c_1 \begin{bmatrix} 1 \\ 1 \end{bmatrix} e^{6t} + c_2 \begin{bmatrix} 1 \\ -1 \end{bmatrix} e^{-2t}$$

$$(b) \quad \begin{aligned} y_1' &= -2y_1 - 2y_2 \\ y_2' &= -5y_1 + y_2; \end{aligned} \quad \mathbf{y} = c_1 \begin{bmatrix} 1 \\ 1 \end{bmatrix} e^{-4t} + c_2 \begin{bmatrix} -2 \\ 5 \end{bmatrix} e^{3t}$$

$$(c) \quad \begin{aligned} y_1' &= -4y_1 - 10y_2 \\ y_2' &= 3y_1 + 7y_2; \end{aligned} \quad \mathbf{y} = c_1 \begin{bmatrix} -5 \\ 3 \end{bmatrix} e^{2t} + c_2 \begin{bmatrix} 2 \\ -1 \end{bmatrix} e^t$$

$$(d) \quad \begin{aligned} y_1' &= 2y_1 + y_2 \\ y_2' &= y_1 + 2y_2; \end{aligned} \quad \mathbf{y} = c_1 \begin{bmatrix} 1 \\ 1 \end{bmatrix} e^{3t} + c_2 \begin{bmatrix} 1 \\ -1 \end{bmatrix} e^t$$

2. Rewrite the system in matrix form and verify that the given vector function satisfies the system for any choice of the constants  $c_1$ ,  $c_2$ , and  $c_3$ .

$$(a) \quad \begin{aligned} y_1' &= -y_1 + 2y_2 + 3y_3 \\ y_2' &= y_2 + 6y_3 \\ y_3' &= -2y_3; \end{aligned}$$

$$\mathbf{y} = c_1 \begin{bmatrix} 1 \\ 1 \\ 0 \end{bmatrix} e^t + c_2 \begin{bmatrix} 1 \\ 0 \\ 0 \end{bmatrix} e^{-t} + c_3 \begin{bmatrix} 1 \\ -2 \\ 1 \end{bmatrix} e^{-2t}$$

$$(b) \quad \begin{aligned} y_1' &= 2y_2 + 2y_3 \\ y_2' &= 2y_1 + 2y_3 \\ y_3' &= 2y_1 + 2y_2; \end{aligned}$$

$$\mathbf{y} = c_1 \begin{bmatrix} -1 \\ 0 \\ 1 \end{bmatrix} e^{-2t} + c_2 \begin{bmatrix} 0 \\ -1 \\ 1 \end{bmatrix} e^{-2t} + c_3 \begin{bmatrix} 1 \\ 1 \\ 1 \end{bmatrix} e^{4t}$$

$$(c) \quad \begin{aligned} y_1' &= -y_1 + 2y_2 + 2y_3 \\ y_2' &= 2y_1 - y_2 + 2y_3 \\ y_3' &= 2y_1 + 2y_2 - y_3; \end{aligned}$$

$$\mathbf{y} = c_1 \begin{bmatrix} -1 \\ 0 \\ 1 \end{bmatrix} e^{-3t} + c_2 \begin{bmatrix} 0 \\ -1 \\ 1 \end{bmatrix} e^{-3t} + c_3 \begin{bmatrix} 1 \\ 1 \\ 1 \end{bmatrix} e^{3t}$$

$$(d) \quad \begin{aligned} y_1' &= 3y_1 - y_2 - y_3 \\ y_2' &= -2y_1 + 3y_2 + 2y_3 \\ y_3' &= 4y_1 - y_2 - 2y_3; \end{aligned}$$

$$\mathbf{y} = c_1 \begin{bmatrix} 1 \\ 0 \\ 1 \end{bmatrix} e^{2t} + c_2 \begin{bmatrix} 1 \\ -1 \\ 1 \end{bmatrix} e^{3t} + c_3 \begin{bmatrix} 1 \\ -3 \\ 7 \end{bmatrix} e^{-t}$$

3. Rewrite the initial value problem in matrix form and verify that the given vector function is a solution.

$$(a) \quad \begin{aligned} y_1' &= y_1 + y_2 & y_1(0) &= 1 \\ y_2' &= -2y_1 + 4y_2, & y_2(0) &= 0; \end{aligned} \quad \mathbf{y} = 2 \begin{bmatrix} 1 \\ 1 \end{bmatrix} e^{2t} - \begin{bmatrix} 1 \\ 2 \end{bmatrix} e^{3t}$$

$$(b) \quad \begin{aligned} y_1' &= 5y_1 + 3y_2 & y_1(0) &= 12 \\ y_2' &= -y_1 + y_2, & y_2(0) &= -6; \end{aligned} \quad \mathbf{y} = 3 \begin{bmatrix} 1 \\ -1 \end{bmatrix} e^{2t} + 3 \begin{bmatrix} 3 \\ -1 \end{bmatrix} e^{4t}$$

4. Rewrite the initial value problem in matrix form and verify that the given vector function is a solution.

$$\begin{aligned} \text{(a)} \quad y_1' &= 6y_1 + 4y_2 + 4y_3 & y_1(0) &= 3 \\ y_2' &= -7y_1 - 2y_2 - y_3, & y_2(0) &= -6 \\ y_3' &= 7y_1 + 4y_2 + 3y_3 & y_3(0) &= 4 \end{aligned}$$

$$\mathbf{y} = \begin{bmatrix} 1 \\ -1 \\ 1 \end{bmatrix} e^{6t} + 2 \begin{bmatrix} 1 \\ -2 \\ 1 \end{bmatrix} e^{2t} + \begin{bmatrix} 0 \\ -1 \\ 1 \end{bmatrix} e^{-t}$$

$$\begin{aligned} \text{(b)} \quad y_1' &= 8y_1 + 7y_2 + 7y_3 & y_1(0) &= 2 \\ y_2' &= -5y_1 - 6y_2 - 9y_3, & y_2(0) &= -4 \\ y_3' &= 5y_1 + 7y_2 + 10y_3, & y_3(0) &= 3 \end{aligned}$$

$$\mathbf{y} = \begin{bmatrix} 1 \\ -1 \\ 1 \end{bmatrix} e^{8t} + \begin{bmatrix} 0 \\ -1 \\ 1 \end{bmatrix} e^{3t} + \begin{bmatrix} 1 \\ -2 \\ 1 \end{bmatrix} e^t$$

5. Rewrite the system in matrix form and verify that the given vector function satisfies the system for any choice of the constants  $c_1$  and  $c_2$ .

$$\begin{aligned} \text{(a)} \quad y_1' &= -3y_1 + 2y_2 + 3 - 2t \\ y_2' &= -5y_1 + 3y_2 + 6 - 3t \end{aligned}$$

$$\mathbf{y} = c_1 \begin{bmatrix} 2 \cos t \\ 3 \cos t - \sin t \end{bmatrix} + c_2 \begin{bmatrix} 2 \sin t \\ 3 \sin t + \cos t \end{bmatrix} + \begin{bmatrix} 1 \\ t \end{bmatrix}$$

$$\begin{aligned} \text{(b)} \quad y_1' &= 3y_1 + y_2 - 5e^t \\ y_2' &= -y_1 + y_2 + e^t \end{aligned}$$

$$\mathbf{y} = c_1 \begin{bmatrix} -1 \\ 1 \end{bmatrix} e^{2t} + c_2 \begin{bmatrix} 1+t \\ -t \end{bmatrix} e^{2t} + \begin{bmatrix} 1 \\ 3 \end{bmatrix} e^t$$

$$\begin{aligned} \text{(c)} \quad y_1' &= -y_1 - 4y_2 + 4e^t + 8te^t \\ y_2' &= -y_1 - y_2 + e^{3t} + (4t+2)e^t \end{aligned}$$

$$\mathbf{y} = c_1 \begin{bmatrix} 2 \\ 1 \end{bmatrix} e^{-3t} + c_2 \begin{bmatrix} -2 \\ 1 \end{bmatrix} e^t + \begin{bmatrix} e^{3t} \\ 2te^t \end{bmatrix}$$

$$\begin{aligned} \text{(d)} \quad y_1' &= -6y_1 - 3y_2 + 14e^{2t} + 12e^t \\ y_2' &= y_1 - 2y_2 + 7e^{2t} - 12e^t \end{aligned}$$

$$\mathbf{y} = c_1 \begin{bmatrix} -3 \\ 1 \end{bmatrix} e^{-5t} + c_2 \begin{bmatrix} -1 \\ 1 \end{bmatrix} e^{-3t} + \begin{bmatrix} e^{2t} + 3e^t \\ 2e^{2t} - 3e^t \end{bmatrix}$$

6. Convert the linear scalar equation

$$P_0(t)y^{(n)} + P_1(t)y^{(n-1)} + \cdots + P_n(t)y(t) = F(t) \quad (\text{A})$$

into an equivalent  $n \times n$  system

$$\mathbf{y}' = A(t)\mathbf{y} + \mathbf{f}(t),$$

and show that  $A$  and  $\mathbf{f}$  are continuous on an interval  $(a, b)$  if and only if (A) is normal on  $(a, b)$ .

7. A matrix function

$$Q(t) = \begin{bmatrix} q_{11}(t) & q_{12}(t) & \cdots & q_{1s}(t) \\ q_{21}(t) & q_{22}(t) & \cdots & q_{2s}(t) \\ \vdots & \vdots & \ddots & \vdots \\ q_{r1}(t) & q_{r2}(t) & \cdots & q_{rs}(t) \end{bmatrix}$$

is said to be *differentiable* if its entries  $\{q_{ij}\}$  are differentiable. Then the *derivative*  $Q'$  is defined by

$$Q'(t) = \begin{bmatrix} q'_{11}(t) & q'_{12}(t) & \cdots & q'_{1s}(t) \\ q'_{21}(t) & q'_{22}(t) & \cdots & q'_{2s}(t) \\ \vdots & \vdots & \ddots & \vdots \\ q'_{r1}(t) & q'_{r2}(t) & \cdots & q'_{rs}(t) \end{bmatrix}.$$

- (a) Prove: If  $P$  and  $Q$  are differentiable matrices such that  $P + Q$  is defined and if  $c_1$  and  $c_2$  are constants, then

$$(c_1P + c_2Q)' = c_1P' + c_2Q'.$$

- (b) Prove: If  $P$  and  $Q$  are differentiable matrices such that  $PQ$  is defined, then

$$(PQ)' = P'Q + PQ'.$$

8. Verify that  $Y' = AY$ .

(a)  $Y = \begin{bmatrix} e^{6t} & e^{-2t} \\ e^{6t} & -e^{-2t} \end{bmatrix}, \quad A = \begin{bmatrix} 2 & 4 \\ 4 & 2 \end{bmatrix}$

(b)  $Y = \begin{bmatrix} e^{-4t} & -2e^{3t} \\ e^{-4t} & 5e^{3t} \end{bmatrix}, \quad A = \begin{bmatrix} -2 & -2 \\ -5 & 1 \end{bmatrix}$

(c)  $Y = \begin{bmatrix} -5e^{2t} & 2e^t \\ 3e^{2t} & -e^t \end{bmatrix}, \quad A = \begin{bmatrix} -4 & -10 \\ 3 & 7 \end{bmatrix}$

(d)  $Y = \begin{bmatrix} e^{3t} & e^t \\ e^{3t} & -e^t \end{bmatrix}, \quad A = \begin{bmatrix} 2 & 1 \\ 1 & 2 \end{bmatrix}$

(e)  $Y = \begin{bmatrix} e^t & e^{-t} & e^{-2t} \\ e^t & 0 & -2e^{-2t} \\ 0 & 0 & e^{-2t} \end{bmatrix}, \quad A = \begin{bmatrix} -1 & 2 & 3 \\ 0 & 1 & 6 \\ 0 & 0 & -2 \end{bmatrix}$

(f)  $Y = \begin{bmatrix} -e^{-2t} & -e^{-2t} & e^{4t} \\ 0 & e^{-2t} & e^{4t} \\ e^{-2t} & 0 & e^{4t} \end{bmatrix}, \quad A = \begin{bmatrix} 0 & 2 & 2 \\ 2 & 0 & 2 \\ 2 & 2 & 0 \end{bmatrix}$

(g)  $Y = \begin{bmatrix} e^{3t} & e^{-3t} & 0 \\ e^{3t} & 0 & -e^{-3t} \\ e^{3t} & e^{-3t} & e^{-3t} \end{bmatrix}, \quad A = \begin{bmatrix} -9 & 6 & 6 \\ -6 & 3 & 6 \\ -6 & 6 & 3 \end{bmatrix}$

(h)  $Y = \begin{bmatrix} e^{2t} & e^{3t} & e^{-t} \\ 0 & -e^{3t} & -3e^{-t} \\ e^{2t} & e^{3t} & 7e^{-t} \end{bmatrix}, \quad A = \begin{bmatrix} 3 & -1 & -1 \\ -2 & 3 & 2 \\ 4 & -1 & -2 \end{bmatrix}$

9. Suppose

$$\mathbf{y}_1 = \begin{bmatrix} y_{11} \\ y_{21} \end{bmatrix} \quad \text{and} \quad \mathbf{y}_2 = \begin{bmatrix} y_{12} \\ y_{22} \end{bmatrix}$$

are solutions of the homogeneous system

$$\mathbf{y}' = A(t)\mathbf{y}, \tag{A}$$

and define

$$Y = \begin{bmatrix} y_{11} & y_{12} \\ y_{21} & y_{22} \end{bmatrix}.$$

- (a) Show that  $Y' = AY$ .  
 (b) Show that if  $\mathbf{c}$  is a constant vector then  $\mathbf{y} = Y\mathbf{c}$  is a solution of (A).  
 (c) State generalizations of (a) and (b) for  $n \times n$  systems.

10. Suppose  $Y$  is a differentiable square matrix.
- Find a formula for the derivative of  $Y^2$ .
  - Find a formula for the derivative of  $Y^n$ , where  $n$  is any positive integer.
  - State how the results obtained in (a) and (b) are analogous to results from calculus concerning scalar functions.
11. It can be shown that if  $Y$  is a differentiable and invertible square matrix function, then  $Y^{-1}$  is differentiable.
- Show that  $(Y^{-1})' = -Y^{-1}Y'Y^{-1}$ . (Hint: Differentiate the identity  $Y^{-1}Y = I$ .)
  - Find the derivative of  $Y^{-n} = (Y^{-1})^n$ , where  $n$  is a positive integer.
  - State how the results obtained in (a) and (b) are analogous to results from calculus concerning scalar functions.
12. Show that Theorem 10.2.1 implies Theorem 9.1.1. HINT: Write the scalar equation
- $$P_0(x)y^{(n)} + P_1(x)y^{(n-1)} + \cdots + P_n(x)y = F(x)$$
- as an  $n \times n$  system of linear equations.
13. Suppose  $\mathbf{y}$  is a solution of the  $n \times n$  system  $\mathbf{y}' = A(t)\mathbf{y}$  on  $(a, b)$ , and that the  $n \times n$  matrix  $P$  is invertible and differentiable on  $(a, b)$ . Find a matrix  $B$  such that the function  $\mathbf{x} = P\mathbf{y}$  is a solution of  $\mathbf{x}' = B\mathbf{x}$  on  $(a, b)$ .

### 10.3 BASIC THEORY OF HOMOGENEOUS LINEAR SYSTEMS

In this section we consider homogeneous linear systems  $\mathbf{y}' = A(t)\mathbf{y}$ , where  $A = A(t)$  is a continuous  $n \times n$  matrix function on an interval  $(a, b)$ . The theory of linear homogeneous systems has much in common with the theory of linear homogeneous scalar equations, which we considered in Sections 2.1, 5.1, and 9.1.

Whenever we refer to solutions of  $\mathbf{y}' = A(t)\mathbf{y}$  we'll mean solutions on  $(a, b)$ . Since  $\mathbf{y} \equiv \mathbf{0}$  is obviously a solution of  $\mathbf{y}' = A(t)\mathbf{y}$ , we call it the *trivial* solution. Any other solution is *nontrivial*.

If  $\mathbf{y}_1, \mathbf{y}_2, \dots, \mathbf{y}_n$  are vector functions defined on an interval  $(a, b)$  and  $c_1, c_2, \dots, c_n$  are constants, then

$$\mathbf{y} = c_1\mathbf{y}_1 + c_2\mathbf{y}_2 + \cdots + c_n\mathbf{y}_n \quad (10.3.1)$$

is a *linear combination of*  $\mathbf{y}_1, \mathbf{y}_2, \dots, \mathbf{y}_n$ . It's easy to show that if  $\mathbf{y}_1, \mathbf{y}_2, \dots, \mathbf{y}_n$  are solutions of  $\mathbf{y}' = A(t)\mathbf{y}$  on  $(a, b)$ , then so is any linear combination of  $\mathbf{y}_1, \mathbf{y}_2, \dots, \mathbf{y}_n$  (Exercise 1). We say that  $\{\mathbf{y}_1, \mathbf{y}_2, \dots, \mathbf{y}_n\}$  is a *fundamental set of solutions of*  $\mathbf{y}' = A(t)\mathbf{y}$  on  $(a, b)$  on if every solution of  $\mathbf{y}' = A(t)\mathbf{y}$  on  $(a, b)$  can be written as a linear combination of  $\mathbf{y}_1, \mathbf{y}_2, \dots, \mathbf{y}_n$ , as in (10.3.1). In this case we say that (10.3.1) is the *general solution of*  $\mathbf{y}' = A(t)\mathbf{y}$  on  $(a, b)$ .

It can be shown that if  $A$  is continuous on  $(a, b)$  then  $\mathbf{y}' = A(t)\mathbf{y}$  has infinitely many fundamental sets of solutions on  $(a, b)$  (Exercises 15 and 16). The next definition will help to characterize fundamental sets of solutions of  $\mathbf{y}' = A(t)\mathbf{y}$ .

We say that a set  $\{\mathbf{y}_1, \mathbf{y}_2, \dots, \mathbf{y}_n\}$  of  $n$ -vector functions is *linearly independent* on  $(a, b)$  if the only constants  $c_1, c_2, \dots, c_n$  such that

$$c_1\mathbf{y}_1(t) + c_2\mathbf{y}_2(t) + \cdots + c_n\mathbf{y}_n(t) = \mathbf{0}, \quad a < t < b, \quad (10.3.2)$$

are  $c_1 = c_2 = \cdots = c_n = 0$ . If (10.3.2) holds for some set of constants  $c_1, c_2, \dots, c_n$  that are not all zero, then  $\{\mathbf{y}_1, \mathbf{y}_2, \dots, \mathbf{y}_n\}$  is *linearly dependent* on  $(a, b)$ .

The next theorem is analogous to Theorems 5.1.3 and 9.1.2.



**Theorem 10.3.1** Suppose the  $n \times n$  matrix  $A = A(t)$  is continuous on  $(a, b)$ . Then a set  $\{\mathbf{y}_1, \mathbf{y}_2, \dots, \mathbf{y}_n\}$  of  $n$  solutions of  $\mathbf{y}' = A(t)\mathbf{y}$  on  $(a, b)$  is a fundamental set if and only if it's linearly independent on  $(a, b)$ .

**Example 10.3.1** Show that the vector functions

$$\mathbf{y}_1 = \begin{bmatrix} e^t \\ 0 \\ e^{-t} \end{bmatrix}, \quad \mathbf{y}_2 = \begin{bmatrix} 0 \\ e^{3t} \\ 1 \end{bmatrix}, \quad \text{and} \quad \mathbf{y}_3 = \begin{bmatrix} e^{2t} \\ e^{3t} \\ 0 \end{bmatrix}$$

are linearly independent on every interval  $(a, b)$ .

**Solution** Suppose

$$c_1 \begin{bmatrix} e^t \\ 0 \\ e^{-t} \end{bmatrix} + c_2 \begin{bmatrix} 0 \\ e^{3t} \\ 1 \end{bmatrix} + c_3 \begin{bmatrix} e^{2t} \\ e^{3t} \\ 0 \end{bmatrix} = \begin{bmatrix} 0 \\ 0 \\ 0 \end{bmatrix}, \quad a < t < b.$$

We must show that  $c_1 = c_2 = c_3 = 0$ . Rewriting this equation in matrix form yields

$$\begin{bmatrix} e^t & 0 & e^{2t} \\ 0 & e^{3t} & e^{3t} \\ e^{-t} & 1 & 0 \end{bmatrix} \begin{bmatrix} c_1 \\ c_2 \\ c_3 \end{bmatrix} = \begin{bmatrix} 0 \\ 0 \\ 0 \end{bmatrix}, \quad a < t < b.$$

Expanding the determinant of this system in cofactors of the entries of the first row yields

$$\begin{aligned} \begin{vmatrix} e^t & 0 & e^{2t} \\ 0 & e^{3t} & e^{3t} \\ e^{-t} & 1 & 0 \end{vmatrix} &= e^t \begin{vmatrix} e^{3t} & e^{3t} \\ e^{-t} & 0 \end{vmatrix} - 0 \begin{vmatrix} e^{3t} & e^{3t} \\ e^{-t} & 1 \end{vmatrix} + e^{2t} \begin{vmatrix} 0 & e^{3t} \\ e^{-t} & 1 \end{vmatrix} \\ &= e^t(-e^{3t}) + e^{2t}(-e^{2t}) = -2e^{4t}. \end{aligned}$$

Since this determinant is never zero,  $c_1 = c_2 = c_3 = 0$ . ■

We can use the method in Example 10.3.1 to test  $n$  solutions  $\{\mathbf{y}_1, \mathbf{y}_2, \dots, \mathbf{y}_n\}$  of any  $n \times n$  system  $\mathbf{y}' = A(t)\mathbf{y}$  for linear independence on an interval  $(a, b)$  on which  $A$  is continuous. To explain this (and for other purposes later), it's useful to write a linear combination of  $\mathbf{y}_1, \mathbf{y}_2, \dots, \mathbf{y}_n$  in a different way. We first write the vector functions in terms of their components as

$$\mathbf{y}_1 = \begin{bmatrix} y_{11} \\ y_{21} \\ \vdots \\ y_{n1} \end{bmatrix}, \quad \mathbf{y}_2 = \begin{bmatrix} y_{12} \\ y_{22} \\ \vdots \\ y_{n2} \end{bmatrix}, \quad \dots, \quad \mathbf{y}_n = \begin{bmatrix} y_{1n} \\ y_{2n} \\ \vdots \\ y_{nn} \end{bmatrix}.$$

If

$$\mathbf{y} = c_1\mathbf{y}_1 + c_2\mathbf{y}_2 + \dots + c_n\mathbf{y}_n$$

then

$$\begin{aligned} \mathbf{y} &= c_1 \begin{bmatrix} y_{11} \\ y_{21} \\ \vdots \\ y_{n1} \end{bmatrix} + c_2 \begin{bmatrix} y_{12} \\ y_{22} \\ \vdots \\ y_{n2} \end{bmatrix} + \dots + c_n \begin{bmatrix} y_{1n} \\ y_{2n} \\ \vdots \\ y_{nn} \end{bmatrix} \\ &= \begin{bmatrix} y_{11} & y_{12} & \cdots & y_{1n} \\ y_{21} & y_{22} & \cdots & y_{2n} \\ \vdots & \vdots & \ddots & \vdots \\ y_{n1} & y_{n2} & \cdots & y_{nn} \end{bmatrix} \begin{bmatrix} c_1 \\ c_2 \\ \vdots \\ c_n \end{bmatrix}. \end{aligned}$$

This shows that

$$c_1 \mathbf{y}_1 + c_2 \mathbf{y}_2 + \cdots + c_n \mathbf{y}_n = Y \mathbf{c}, \quad (10.3.3)$$

where

$$\mathbf{c} = \begin{bmatrix} c_1 \\ c_2 \\ \vdots \\ c_n \end{bmatrix}$$

and

$$Y = [\mathbf{y}_1 \ \mathbf{y}_2 \ \cdots \ \mathbf{y}_n] = \begin{bmatrix} y_{11} & y_{12} & \cdots & y_{1n} \\ y_{21} & y_{22} & \cdots & y_{2n} \\ \vdots & \vdots & \ddots & \vdots \\ y_{n1} & y_{n2} & \cdots & y_{nn} \end{bmatrix}; \quad (10.3.4)$$

that is, the columns of  $Y$  are the vector functions  $\mathbf{y}_1, \mathbf{y}_2, \dots, \mathbf{y}_n$ .

For reference below, note that

$$\begin{aligned} Y' &= [\mathbf{y}'_1 \ \mathbf{y}'_2 \ \cdots \ \mathbf{y}'_n] \\ &= [A\mathbf{y}_1 \ A\mathbf{y}_2 \ \cdots \ A\mathbf{y}_n] \\ &= A[\mathbf{y}_1 \ \mathbf{y}_2 \ \cdots \ \mathbf{y}_n] = AY; \end{aligned}$$

that is,  $Y$  satisfies the matrix differential equation

$$Y' = AY.$$

The determinant of  $Y$ ,

$$W = \begin{vmatrix} y_{11} & y_{12} & \cdots & y_{1n} \\ y_{21} & y_{22} & \cdots & y_{2n} \\ \vdots & \vdots & \ddots & \vdots \\ y_{n1} & y_{n2} & \cdots & y_{nn} \end{vmatrix} \quad (10.3.5)$$

is called the *Wronskian* of  $\{\mathbf{y}_1, \mathbf{y}_2, \dots, \mathbf{y}_n\}$ . It can be shown (Exercises 2 and 3) that this definition is analogous to definitions of the Wronskian of scalar functions given in Sections 5.1 and 9.1. The next theorem is analogous to Theorems 5.1.4 and 9.1.3. The proof is sketched in Exercise 4 for  $n = 2$  and in Exercise 5 for general  $n$ .

**Theorem 10.3.2** [Abel's Formula] *Suppose the  $n \times n$  matrix  $A = A(t)$  is continuous on  $(a, b)$ , let  $\mathbf{y}_1, \mathbf{y}_2, \dots, \mathbf{y}_n$  be solutions of  $\mathbf{y}' = A(t)\mathbf{y}$  on  $(a, b)$ , and let  $t_0$  be in  $(a, b)$ . Then the Wronskian of  $\{\mathbf{y}_1, \mathbf{y}_2, \dots, \mathbf{y}_n\}$  is given by*

$$W(t) = W(t_0) \exp \left( \int_{t_0}^t [a_{11}(s) + a_{22}(s) + \cdots + a_{nn}(s)] ds \right), \quad a < t < b. \quad (10.3.6)$$

Therefore, either  $W$  has no zeros in  $(a, b)$  or  $W \equiv 0$  on  $(a, b)$ .

**REMARK:** The sum of the diagonal entries of a square matrix  $A$  is called the *trace* of  $A$ , denoted by  $\text{tr}(A)$ . Thus, for an  $n \times n$  matrix  $A$ ,

$$\text{tr}(A) = a_{11} + a_{22} + \cdots + a_{nn},$$

and (10.3.6) can be written as

$$W(t) = W(t_0) \exp \left( \int_{t_0}^t \operatorname{tr}(A(s)) ds \right), \quad a < t < b.$$

The next theorem is analogous to Theorems 5.1.6 and 9.1.4.

**Theorem 10.3.3** Suppose the  $n \times n$  matrix  $A = A(t)$  is continuous on  $(a, b)$  and let  $\mathbf{y}_1, \mathbf{y}_2, \dots, \mathbf{y}_n$  be solutions of  $\mathbf{y}' = A(t)\mathbf{y}$  on  $(a, b)$ . Then the following statements are equivalent; that is, they are either all true or all false:

- (a) The general solution of  $\mathbf{y}' = A(t)\mathbf{y}$  on  $(a, b)$  is  $\mathbf{y} = c_1\mathbf{y}_1 + c_2\mathbf{y}_2 + \dots + c_n\mathbf{y}_n$ , where  $c_1, c_2, \dots, c_n$  are arbitrary constants.
- (b)  $\{\mathbf{y}_1, \mathbf{y}_2, \dots, \mathbf{y}_n\}$  is a fundamental set of solutions of  $\mathbf{y}' = A(t)\mathbf{y}$  on  $(a, b)$ .
- (c)  $\{\mathbf{y}_1, \mathbf{y}_2, \dots, \mathbf{y}_n\}$  is linearly independent on  $(a, b)$ .
- (d) The Wronskian of  $\{\mathbf{y}_1, \mathbf{y}_2, \dots, \mathbf{y}_n\}$  is nonzero at some point in  $(a, b)$ .
- (e) The Wronskian of  $\{\mathbf{y}_1, \mathbf{y}_2, \dots, \mathbf{y}_n\}$  is nonzero at all points in  $(a, b)$ .

We say that  $Y$  in (10.3.4) is a *fundamental matrix* for  $\mathbf{y}' = A(t)\mathbf{y}$  if any (and therefore all) of the statements (a)-(e) of Theorem 10.3.2 are true for the columns of  $Y$ . In this case, (10.3.3) implies that the general solution of  $\mathbf{y}' = A(t)\mathbf{y}$  can be written as  $\mathbf{y} = Y\mathbf{c}$ , where  $\mathbf{c}$  is an arbitrary constant  $n$ -vector.

**Example 10.3.2** The vector functions

$$\mathbf{y}_1 = \begin{bmatrix} -e^{2t} \\ 2e^{2t} \end{bmatrix} \quad \text{and} \quad \mathbf{y}_2 = \begin{bmatrix} -e^{-t} \\ e^{-t} \end{bmatrix}$$

are solutions of the constant coefficient system

$$\mathbf{y}' = \begin{bmatrix} -4 & -3 \\ 6 & 5 \end{bmatrix} \mathbf{y} \tag{10.3.7}$$

on  $(-\infty, \infty)$ . (Verify.)

- (a) Compute the Wronskian of  $\{\mathbf{y}_1, \mathbf{y}_2\}$  directly from the definition (10.3.5)
- (b) Verify Abel's formula (10.3.6) for the Wronskian of  $\{\mathbf{y}_1, \mathbf{y}_2\}$ .
- (c) Find the general solution of (10.3.7).
- (d) Solve the initial value problem

$$\mathbf{y}' = \begin{bmatrix} -4 & -3 \\ 6 & 5 \end{bmatrix} \mathbf{y}, \quad \mathbf{y}(0) = \begin{bmatrix} 4 \\ -5 \end{bmatrix}. \tag{10.3.8}$$

**SOLUTION(a)** From (10.3.5)

$$W(t) = \begin{vmatrix} -e^{2t} & -e^{-t} \\ 2e^{2t} & e^{-t} \end{vmatrix} = e^{2t}e^{-t} \begin{bmatrix} -1 & -1 \\ 2 & 1 \end{bmatrix} = e^t. \tag{10.3.9}$$

**SOLUTION(b)** Here

$$A = \begin{bmatrix} -4 & -3 \\ 6 & 5 \end{bmatrix},$$

so  $\text{tr}(A) = -4 + 5 = 1$ . If  $t_0$  is an arbitrary real number then (10.3.6) implies that

$$W(t) = W(t_0) \exp \left( \int_{t_0}^t 1 \, ds \right) = \begin{vmatrix} -e^{2t_0} & -e^{-t_0} \\ 2e^{2t_0} & e^{-t_0} \end{vmatrix} e^{(t-t_0)} = e^{t_0} e^{t-t_0} = e^t,$$

which is consistent with (10.3.9).

**SOLUTION(c)** Since  $W(t) \neq 0$ , Theorem 10.3.3 implies that  $\{y_1, y_2\}$  is a fundamental set of solutions of (10.3.7) and

$$Y = \begin{bmatrix} -e^{2t} & -e^{-t} \\ 2e^{2t} & e^{-t} \end{bmatrix}$$

is a fundamental matrix for (10.3.7). Therefore the general solution of (10.3.7) is

$$\mathbf{y} = c_1 \mathbf{y}_1 + c_2 \mathbf{y}_2 = c_1 \begin{bmatrix} -e^{2t} \\ 2e^{2t} \end{bmatrix} + c_2 \begin{bmatrix} -e^{-t} \\ e^{-t} \end{bmatrix} = \begin{bmatrix} -e^{2t} & -e^{-t} \\ 2e^{2t} & e^{-t} \end{bmatrix} \begin{bmatrix} c_1 \\ c_2 \end{bmatrix}. \quad (10.3.10)$$

**SOLUTION(d)** Setting  $t = 0$  in (10.3.10) and imposing the initial condition in (10.3.8) yields

$$c_1 \begin{bmatrix} -1 \\ 2 \end{bmatrix} + c_2 \begin{bmatrix} -1 \\ 1 \end{bmatrix} = \begin{bmatrix} 4 \\ -5 \end{bmatrix}.$$

Thus,

$$\begin{aligned} -c_1 - c_2 &= 4 \\ 2c_1 + c_2 &= -5. \end{aligned}$$

The solution of this system is  $c_1 = -1$ ,  $c_2 = -3$ . Substituting these values into (10.3.10) yields

$$\mathbf{y} = - \begin{bmatrix} -e^{2t} \\ 2e^{2t} \end{bmatrix} - 3 \begin{bmatrix} -e^{-t} \\ e^{-t} \end{bmatrix} = \begin{bmatrix} e^{2t} + 3e^{-t} \\ -2e^{2t} - 3e^{-t} \end{bmatrix}$$

as the solution of (10.3.8).

### 10.3 Exercises

1. Prove: If  $y_1, y_2, \dots, y_n$  are solutions of  $y' = A(t)y$  on  $(a, b)$ , then any linear combination of  $y_1, y_2, \dots, y_n$  is also a solution of  $y' = A(t)y$  on  $(a, b)$ .
2. In Section 5.1 the Wronskian of two solutions  $y_1$  and  $y_2$  of the scalar second order equation

$$P_0(x)y'' + P_1(x)y' + P_2(x)y = 0 \quad (\text{A})$$

was defined to be

$$W = \begin{vmatrix} y_1 & y_2 \\ y_1' & y_2' \end{vmatrix}.$$

- (a) Rewrite (A) as a system of first order equations and show that  $W$  is the Wronskian (as defined in this section) of two solutions of this system.
- (b) Apply Eqn. (10.3.6) to the system derived in (a), and show that

$$W(x) = W(x_0) \exp \left\{ - \int_{x_0}^x \frac{P_1(s)}{P_0(s)} \, ds \right\},$$

which is the form of Abel's formula given in Theorem 9.1.3.

3. In Section 9.1 the Wronskian of  $n$  solutions  $y_1, y_2, \dots, y_n$  of the  $n$ -th order equation

$$P_0(x)y^{(n)} + P_1(x)y^{(n-1)} + \dots + P_n(x)y = 0 \quad (\text{A})$$

was defined to be

$$W = \begin{vmatrix} y_1 & y_2 & \cdots & y_n \\ y_1' & y_2' & \cdots & y_n' \\ \vdots & \vdots & \ddots & \vdots \\ y_1^{(n-1)} & y_2^{(n-1)} & \cdots & y_n^{(n-1)} \end{vmatrix}.$$

- (a) Rewrite (A) as a system of first order equations and show that  $W$  is the Wronskian (as defined in this section) of  $n$  solutions of this system.  
 (b) Apply Eqn. (10.3.6) to the system derived in (a), and show that

$$W(x) = W(x_0) \exp \left\{ - \int_{x_0}^x \frac{P_1(s)}{P_0(s)} ds \right\},$$

which is the form of Abel's formula given in Theorem 9.1.3.

4. Suppose

$$\mathbf{y}_1 = \begin{bmatrix} y_{11} \\ y_{21} \end{bmatrix} \quad \text{and} \quad \mathbf{y}_2 = \begin{bmatrix} y_{12} \\ y_{22} \end{bmatrix}$$

are solutions of the  $2 \times 2$  system  $\mathbf{y}' = A\mathbf{y}$  on  $(a, b)$ , and let

$$Y = \begin{bmatrix} y_{11} & y_{12} \\ y_{21} & y_{22} \end{bmatrix} \quad \text{and} \quad W = \begin{vmatrix} y_{11} & y_{12} \\ y_{21} & y_{22} \end{vmatrix};$$

thus,  $W$  is the Wronskian of  $\{\mathbf{y}_1, \mathbf{y}_2\}$ .

- (a) Deduce from the definition of determinant that

$$W' = \begin{vmatrix} y_{11}' & y_{12}' \\ y_{21} & y_{22} \end{vmatrix} + \begin{vmatrix} y_{11} & y_{12} \\ y_{21}' & y_{22}' \end{vmatrix}.$$

- (b) Use the equation  $Y' = A(t)Y$  and the definition of matrix multiplication to show that

$$[y_{11}' \quad y_{12}'] = a_{11}[y_{11} \quad y_{12}] + a_{12}[y_{21} \quad y_{22}]$$

and

$$[y_{21}' \quad y_{22}'] = a_{21}[y_{11} \quad y_{12}] + a_{22}[y_{21} \quad y_{22}].$$

- (c) Use properties of determinants to deduce from (a) and (b) that

$$\begin{vmatrix} y_{11}' & y_{12}' \\ y_{21} & y_{22} \end{vmatrix} = a_{11}W \quad \text{and} \quad \begin{vmatrix} y_{11} & y_{12} \\ y_{21}' & y_{22}' \end{vmatrix} = a_{22}W.$$

- (d) Conclude from (c) that

$$W' = (a_{11} + a_{22})W,$$

and use this to show that if  $a < t_0 < b$  then

$$W(t) = W(t_0) \exp \left( \int_{t_0}^t [a_{11}(s) + a_{22}(s)] ds \right) \quad a < t < b.$$

5. Suppose the  $n \times n$  matrix  $A = A(t)$  is continuous on  $(a, b)$ . Let

$$Y = \begin{bmatrix} y_{11} & y_{12} & \cdots & y_{1n} \\ y_{21} & y_{22} & \cdots & y_{2n} \\ \vdots & \vdots & \ddots & \vdots \\ y_{n1} & y_{n2} & \cdots & y_{nn} \end{bmatrix},$$

where the columns of  $Y$  are solutions of  $\mathbf{y}' = A(t)\mathbf{y}$ . Let

$$r_i = [y_{i1} \ y_{i2} \ \cdots \ y_{in}]$$

be the  $i$ th row of  $Y$ , and let  $W$  be the determinant of  $Y$ .

- (a) Deduce from the definition of determinant that

$$W' = W_1 + W_2 + \cdots + W_n,$$

where, for  $1 \leq m \leq n$ , the  $i$ th row of  $W_m$  is  $r_i$  if  $i \neq m$ , and  $r'_m$  if  $i = m$ .

- (b) Use the equation  $Y' = AY$  and the definition of matrix multiplication to show that

$$r'_m = a_{m1}r_1 + a_{m2}r_2 + \cdots + a_{mn}r_n.$$

- (c) Use properties of determinants to deduce from (b) that

$$\det(W_m) = a_{mm}W.$$

- (d) Conclude from (a) and (c) that

$$W' = (a_{11} + a_{22} + \cdots + a_{nn})W,$$

and use this to show that if  $a < t_0 < b$  then

$$W(t) = W(t_0) \exp \left( \int_{t_0}^t [a_{11}(s) + a_{22}(s) + \cdots + a_{nn}(s)] ds \right), \quad a < t < b.$$

6. Suppose the  $n \times n$  matrix  $A$  is continuous on  $(a, b)$  and  $t_0$  is a point in  $(a, b)$ . Let  $Y$  be a fundamental matrix for  $\mathbf{y}' = A(t)\mathbf{y}$  on  $(a, b)$ .

- (a) Show that  $Y(t_0)$  is invertible.

- (b) Show that if  $\mathbf{k}$  is an arbitrary  $n$ -vector then the solution of the initial value problem

$$\mathbf{y}' = A(t)\mathbf{y}, \quad \mathbf{y}(t_0) = \mathbf{k}$$

is

$$\mathbf{y} = Y(t)Y^{-1}(t_0)\mathbf{k}.$$

7. Let

$$A = \begin{bmatrix} 2 & 4 \\ 4 & 2 \end{bmatrix}, \quad \mathbf{y}_1 = \begin{bmatrix} e^{6t} \\ e^{6t} \end{bmatrix}, \quad \mathbf{y}_2 = \begin{bmatrix} e^{-2t} \\ -e^{-2t} \end{bmatrix}, \quad \mathbf{k} = \begin{bmatrix} -3 \\ 9 \end{bmatrix}.$$

- (a) Verify that  $\{\mathbf{y}_1, \mathbf{y}_2\}$  is a fundamental set of solutions for  $\mathbf{y}' = A\mathbf{y}$ .

- (b) Solve the initial value problem

$$\mathbf{y}' = A\mathbf{y}, \quad \mathbf{y}(0) = \mathbf{k}. \tag{A}$$

(c) Use the result of Exercise 6(b) to find a formula for the solution of (A) for an arbitrary initial vector  $\mathbf{k}$ .

8. Repeat Exercise 7 with

$$A = \begin{bmatrix} -2 & -2 \\ -5 & 1 \end{bmatrix}, \quad \mathbf{y}_1 = \begin{bmatrix} e^{-4t} \\ e^{-4t} \end{bmatrix}, \quad \mathbf{y}_2 = \begin{bmatrix} -2e^{3t} \\ 5e^{3t} \end{bmatrix}, \quad \mathbf{k} = \begin{bmatrix} 10 \\ -4 \end{bmatrix}.$$

9. Repeat Exercise 7 with

$$A = \begin{bmatrix} -4 & -10 \\ 3 & 7 \end{bmatrix}, \quad \mathbf{y}_1 = \begin{bmatrix} -5e^{2t} \\ 3e^{2t} \end{bmatrix}, \quad \mathbf{y}_2 = \begin{bmatrix} 2e^t \\ -e^t \end{bmatrix}, \quad \mathbf{k} = \begin{bmatrix} -19 \\ 11 \end{bmatrix}.$$

10. Repeat Exercise 7 with

$$A = \begin{bmatrix} 2 & 1 \\ 1 & 2 \end{bmatrix}, \quad \mathbf{y}_1 = \begin{bmatrix} e^{3t} \\ e^{3t} \end{bmatrix}, \quad \mathbf{y}_2 = \begin{bmatrix} e^t \\ -e^t \end{bmatrix}, \quad \mathbf{k} = \begin{bmatrix} 2 \\ 8 \end{bmatrix}.$$

11. Let

$$A = \begin{bmatrix} 3 & -1 & -1 \\ -2 & 3 & 2 \\ 4 & -1 & -2 \end{bmatrix},$$

$$\mathbf{y}_1 = \begin{bmatrix} e^{2t} \\ 0 \\ e^{2t} \end{bmatrix}, \quad \mathbf{y}_2 = \begin{bmatrix} e^{3t} \\ -e^{3t} \\ e^{3t} \end{bmatrix}, \quad \mathbf{y}_3 = \begin{bmatrix} e^{-t} \\ -3e^{-t} \\ 7e^{-t} \end{bmatrix}, \quad \mathbf{k} = \begin{bmatrix} 2 \\ -7 \\ 20 \end{bmatrix}.$$

(a) Verify that  $\{\mathbf{y}_1, \mathbf{y}_2, \mathbf{y}_3\}$  is a fundamental set of solutions for  $\mathbf{y}' = A\mathbf{y}$ .

(b) Solve the initial value problem

$$\mathbf{y}' = A\mathbf{y}, \quad \mathbf{y}(0) = \mathbf{k}. \quad (\text{A})$$

(c) Use the result of Exercise 6(b) to find a formula for the solution of (A) for an arbitrary initial vector  $\mathbf{k}$ .

12. Repeat Exercise 11 with

$$A = \begin{bmatrix} 0 & 2 & 2 \\ 2 & 0 & 2 \\ 2 & 2 & 0 \end{bmatrix},$$

$$\mathbf{y}_1 = \begin{bmatrix} -e^{-2t} \\ 0 \\ e^{-2t} \end{bmatrix}, \quad \mathbf{y}_2 = \begin{bmatrix} -e^{-2t} \\ e^{-2t} \\ 0 \end{bmatrix}, \quad \mathbf{y}_3 = \begin{bmatrix} e^{4t} \\ e^{4t} \\ e^{4t} \end{bmatrix}, \quad \mathbf{k} = \begin{bmatrix} 0 \\ -9 \\ 12 \end{bmatrix}.$$

13. Repeat Exercise 11 with

$$A = \begin{bmatrix} -1 & 2 & 3 \\ 0 & 1 & 6 \\ 0 & 0 & -2 \end{bmatrix},$$

$$\mathbf{y}_1 = \begin{bmatrix} e^t \\ e^t \\ 0 \end{bmatrix}, \quad \mathbf{y}_2 = \begin{bmatrix} e^{-t} \\ 0 \\ 0 \end{bmatrix}, \quad \mathbf{y}_3 = \begin{bmatrix} e^{-2t} \\ -2e^{-2t} \\ e^{-2t} \end{bmatrix}, \quad \mathbf{k} = \begin{bmatrix} 5 \\ 5 \\ -1 \end{bmatrix}.$$

14. Suppose  $Y$  and  $Z$  are fundamental matrices for the  $n \times n$  system  $\mathbf{y}' = A(t)\mathbf{y}$ . Then some of the four matrices  $YZ^{-1}$ ,  $Y^{-1}Z$ ,  $Z^{-1}Y$ ,  $ZY^{-1}$  are necessarily constant. Identify them and prove that they are constant.
15. Suppose the columns of an  $n \times n$  matrix  $Y$  are solutions of the  $n \times n$  system  $\mathbf{y}' = A\mathbf{y}$  and  $C$  is an  $n \times n$  constant matrix.
- (a) Show that the matrix  $Z = YC$  satisfies the differential equation  $Z' = AZ$ .
- (b) Show that  $Z$  is a fundamental matrix for  $\mathbf{y}' = A(t)\mathbf{y}$  if and only if  $C$  is invertible and  $Y$  is a fundamental matrix for  $\mathbf{y}' = A(t)\mathbf{y}$ .
16. Suppose the  $n \times n$  matrix  $A = A(t)$  is continuous on  $(a, b)$  and  $t_0$  is in  $(a, b)$ . For  $i = 1, 2, \dots, n$ , let  $\mathbf{y}_i$  be the solution of the initial value problem  $\mathbf{y}'_i = A(t)\mathbf{y}_i$ ,  $\mathbf{y}_i(t_0) = \mathbf{e}_i$ , where

$$\mathbf{e}_1 = \begin{bmatrix} 1 \\ 0 \\ \vdots \\ 0 \end{bmatrix}, \quad \mathbf{e}_2 = \begin{bmatrix} 0 \\ 1 \\ \vdots \\ 0 \end{bmatrix}, \quad \dots \quad \mathbf{e}_n = \begin{bmatrix} 0 \\ 0 \\ \vdots \\ 1 \end{bmatrix};$$

that is, the  $j$ th component of  $\mathbf{e}_i$  is 1 if  $j = i$ , or 0 if  $j \neq i$ .

- (a) Show that  $\{\mathbf{y}_1, \mathbf{y}_2, \dots, \mathbf{y}_n\}$  is a fundamental set of solutions of  $\mathbf{y}' = A(t)\mathbf{y}$  on  $(a, b)$ .
- (b) Conclude from (a) and Exercise 15 that  $\mathbf{y}' = A(t)\mathbf{y}$  has infinitely many fundamental sets of solutions on  $(a, b)$ .
17. Show that  $Y$  is a fundamental matrix for the system  $\mathbf{y}' = A(t)\mathbf{y}$  if and only if  $Y^{-1}$  is a fundamental matrix for  $\mathbf{y}' = -A^T(t)\mathbf{y}$ , where  $A^T$  denotes the transpose of  $A$ . HINT: See Exercise 11.
18. Let  $Z$  be the fundamental matrix for the constant coefficient system  $\mathbf{y}' = A\mathbf{y}$  such that  $Z(0) = I$ .
- (a) Show that  $Z(t)Z(s) = Z(t+s)$  for all  $s$  and  $t$ . HINT: For fixed  $s$  let  $\Gamma_1(t) = Z(t)Z(s)$  and  $\Gamma_2(t) = Z(t+s)$ . Show that  $\Gamma_1$  and  $\Gamma_2$  are both solutions of the matrix initial value problem  $\Gamma' = A\Gamma$ ,  $\Gamma(0) = Z(s)$ . Then conclude from Theorem 10.2.1 that  $\Gamma_1 = \Gamma_2$ .
- (b) Show that  $(Z(t))^{-1} = Z(-t)$ .
- (c) The matrix  $Z$  defined above is sometimes denoted by  $e^{tA}$ . Discuss the motivation for this notation.

## 10.4 CONSTANT COEFFICIENT HOMOGENEOUS SYSTEMS I

We'll now begin our study of the homogeneous system

$$\mathbf{y}' = A\mathbf{y}, \tag{10.4.1}$$

where  $A$  is an  $n \times n$  constant matrix. Since  $A$  is continuous on  $(-\infty, \infty)$ , Theorem 10.2.1 implies that all solutions of (10.4.1) are defined on  $(-\infty, \infty)$ . Therefore, when we speak of solutions of  $\mathbf{y}' = A\mathbf{y}$ , we'll mean solutions on  $(-\infty, \infty)$ .

In this section we assume that all the eigenvalues of  $A$  are real and that  $A$  has a set of  $n$  linearly independent eigenvectors. In the next two sections we consider the cases where some of the eigenvalues of  $A$  are complex, or where  $A$  does not have  $n$  linearly independent eigenvectors.

In Example 10.3.2 we showed that the vector functions

$$\mathbf{y}_1 = \begin{bmatrix} -e^{2t} \\ 2e^{2t} \end{bmatrix} \quad \text{and} \quad \mathbf{y}_2 = \begin{bmatrix} -e^{-t} \\ e^{-t} \end{bmatrix}$$

form a fundamental set of solutions of the system

$$\mathbf{y}' = \begin{bmatrix} -4 & -3 \\ 6 & 5 \end{bmatrix} \mathbf{y}, \tag{10.4.2}$$



but we did not show how we obtained  $\mathbf{y}_1$  and  $\mathbf{y}_2$  in the first place. To see how these solutions can be obtained we write (10.4.2) as

$$\begin{aligned}y_1' &= -4y_1 - 3y_2 \\y_2' &= 6y_1 + 5y_2\end{aligned}\tag{10.4.3}$$

and look for solutions of the form

$$y_1 = x_1 e^{\lambda t} \quad \text{and} \quad y_2 = x_2 e^{\lambda t},\tag{10.4.4}$$

where  $x_1$ ,  $x_2$ , and  $\lambda$  are constants to be determined. Differentiating (10.4.4) yields

$$y_1' = \lambda x_1 e^{\lambda t} \quad \text{and} \quad y_2' = \lambda x_2 e^{\lambda t}.$$

Substituting this and (10.4.4) into (10.4.3) and canceling the common factor  $e^{\lambda t}$  yields

$$\begin{aligned}-4x_1 - 3x_2 &= \lambda x_1 \\6x_1 + 5x_2 &= \lambda x_2.\end{aligned}$$

For a given  $\lambda$ , this is a homogeneous algebraic system, since it can be rewritten as

$$\begin{aligned}(-4 - \lambda)x_1 - 3x_2 &= 0 \\6x_1 + (5 - \lambda)x_2 &= 0.\end{aligned}\tag{10.4.5}$$

The trivial solution  $x_1 = x_2 = 0$  of this system isn't useful, since it corresponds to the trivial solution  $y_1 \equiv y_2 \equiv 0$  of (10.4.3), which can't be part of a fundamental set of solutions of (10.4.2). Therefore we consider only those values of  $\lambda$  for which (10.4.5) has nontrivial solutions. These are the values of  $\lambda$  for which the determinant of (10.4.5) is zero; that is,

$$\begin{aligned}\begin{vmatrix} -4 - \lambda & -3 \\ 6 & 5 - \lambda \end{vmatrix} &= (-4 - \lambda)(5 - \lambda) + 18 \\ &= \lambda^2 - \lambda - 2 \\ &= (\lambda - 2)(\lambda + 1) = 0,\end{aligned}$$

which has the solutions  $\lambda_1 = 2$  and  $\lambda_2 = -1$ .

Taking  $\lambda = 2$  in (10.4.5) yields

$$\begin{aligned}-6x_1 - 3x_2 &= 0 \\6x_1 + 3x_2 &= 0,\end{aligned}$$

which implies that  $x_1 = -x_2/2$ , where  $x_2$  can be chosen arbitrarily. Choosing  $x_2 = 2$  yields the solution  $y_1 = -e^{2t}$ ,  $y_2 = 2e^{2t}$  of (10.4.3). We can write this solution in vector form as

$$\mathbf{y}_1 = \begin{bmatrix} -1 \\ 2 \end{bmatrix} e^{2t}.\tag{10.4.6}$$

Taking  $\lambda = -1$  in (10.4.5) yields the system

$$\begin{aligned}-3x_1 - 3x_2 &= 0 \\6x_1 + 6x_2 &= 0,\end{aligned}$$

so  $x_1 = -x_2$ . Taking  $x_2 = 1$  here yields the solution  $y_1 = -e^{-t}$ ,  $y_2 = e^{-t}$  of (10.4.3). We can write this solution in vector form as

$$\mathbf{y}_2 = \begin{bmatrix} -1 \\ 1 \end{bmatrix} e^{-t}.\tag{10.4.7}$$

In (10.4.6) and (10.4.7) the constant coefficients in the arguments of the exponential functions are the eigenvalues of the coefficient matrix in (10.4.2), and the vector coefficients of the exponential functions are associated eigenvectors. This illustrates the next theorem.

**Theorem 10.4.1** Suppose the  $n \times n$  constant matrix  $A$  has  $n$  real eigenvalues  $\lambda_1, \lambda_2, \dots, \lambda_n$  (which need not be distinct) with associated linearly independent eigenvectors  $\mathbf{x}_1, \mathbf{x}_2, \dots, \mathbf{x}_n$ . Then the functions

$$\mathbf{y}_1 = \mathbf{x}_1 e^{\lambda_1 t}, \mathbf{y}_2 = \mathbf{x}_2 e^{\lambda_2 t}, \dots, \mathbf{y}_n = \mathbf{x}_n e^{\lambda_n t}$$

form a fundamental set of solutions of  $\mathbf{y}' = A\mathbf{y}$ ; that is, the general solution of this system is

$$\mathbf{y} = c_1 \mathbf{x}_1 e^{\lambda_1 t} + c_2 \mathbf{x}_2 e^{\lambda_2 t} + \dots + c_n \mathbf{x}_n e^{\lambda_n t}.$$

**Proof** Differentiating  $\mathbf{y}_i = \mathbf{x}_i e^{\lambda_i t}$  and recalling that  $A\mathbf{x}_i = \lambda_i \mathbf{x}_i$  yields

$$\mathbf{y}'_i = \lambda_i \mathbf{x}_i e^{\lambda_i t} = A\mathbf{x}_i e^{\lambda_i t} = A\mathbf{y}_i.$$

This shows that  $\mathbf{y}_i$  is a solution of  $\mathbf{y}' = A\mathbf{y}$ .

The Wronskian of  $\{\mathbf{y}_1, \mathbf{y}_2, \dots, \mathbf{y}_n\}$  is

$$\begin{vmatrix} x_{11}e^{\lambda_1 t} & x_{12}e^{\lambda_2 t} & \cdots & x_{1n}e^{\lambda_n t} \\ x_{21}e^{\lambda_1 t} & x_{22}e^{\lambda_2 t} & \cdots & x_{2n}e^{\lambda_n t} \\ \vdots & \vdots & \ddots & \vdots \\ x_{n1}e^{\lambda_1 t} & x_{n2}e^{\lambda_2 t} & \cdots & x_{nn}e^{\lambda_n t} \end{vmatrix} = e^{\lambda_1 t} e^{\lambda_2 t} \cdots e^{\lambda_n t} \begin{vmatrix} x_{11} & x_{12} & \cdots & x_{1n} \\ x_{21} & x_{22} & \cdots & x_{2n} \\ \vdots & \vdots & \ddots & \vdots \\ x_{n1} & x_{n2} & \cdots & x_{nn} \end{vmatrix}.$$

Since the columns of the determinant on the right are  $\mathbf{x}_1, \mathbf{x}_2, \dots, \mathbf{x}_n$ , which are assumed to be linearly independent, the determinant is nonzero. Therefore Theorem 10.3.3 implies that  $\{\mathbf{y}_1, \mathbf{y}_2, \dots, \mathbf{y}_n\}$  is a fundamental set of solutions of  $\mathbf{y}' = A\mathbf{y}$ .

#### Example 10.4.1

(a) Find the general solution of

$$\mathbf{y}' = \begin{bmatrix} 2 & 4 \\ 4 & 2 \end{bmatrix} \mathbf{y}. \quad (10.4.8)$$

(b) Solve the initial value problem

$$\mathbf{y}' = \begin{bmatrix} 2 & 4 \\ 4 & 2 \end{bmatrix} \mathbf{y}, \quad \mathbf{y}(0) = \begin{bmatrix} 5 \\ -1 \end{bmatrix}. \quad (10.4.9)$$

**SOLUTION(a)** The characteristic polynomial of the coefficient matrix  $A$  in (10.4.8) is

$$\begin{aligned} \begin{vmatrix} 2 - \lambda & 4 \\ 4 & 2 - \lambda \end{vmatrix} &= (\lambda - 2)^2 - 16 \\ &= (\lambda - 2 - 4)(\lambda - 2 + 4) \\ &= (\lambda - 6)(\lambda + 2). \end{aligned}$$

Hence,  $\lambda_1 = 6$  and  $\lambda_2 = -2$  are eigenvalues of  $A$ . To obtain the eigenvectors, we must solve the system

$$\begin{bmatrix} 2 - \lambda & 4 \\ 4 & 2 - \lambda \end{bmatrix} \begin{bmatrix} x_1 \\ x_2 \end{bmatrix} = \begin{bmatrix} 0 \\ 0 \end{bmatrix} \quad (10.4.10)$$

with  $\lambda = 6$  and  $\lambda = -2$ . Setting  $\lambda = 6$  in (10.4.10) yields

$$\begin{bmatrix} -4 & 4 \\ 4 & -4 \end{bmatrix} \begin{bmatrix} x_1 \\ x_2 \end{bmatrix} = \begin{bmatrix} 0 \\ 0 \end{bmatrix},$$

which implies that  $x_1 = x_2$ . Taking  $x_2 = 1$  yields the eigenvector

$$\mathbf{x}_1 = \begin{bmatrix} 1 \\ 1 \end{bmatrix},$$

so

$$\mathbf{y}_1 = \begin{bmatrix} 1 \\ 1 \end{bmatrix} e^{6t}$$

is a solution of (10.4.8). Setting  $\lambda = -2$  in (10.4.10) yields

$$\begin{bmatrix} 4 & 4 \\ 4 & 4 \end{bmatrix} \begin{bmatrix} x_1 \\ x_2 \end{bmatrix} = \begin{bmatrix} 0 \\ 0 \end{bmatrix},$$

which implies that  $x_1 = -x_2$ . Taking  $x_2 = 1$  yields the eigenvector

$$\mathbf{x}_2 = \begin{bmatrix} -1 \\ 1 \end{bmatrix},$$

so

$$\mathbf{y}_2 = \begin{bmatrix} -1 \\ 1 \end{bmatrix} e^{-2t}$$

is a solution of (10.4.8). From Theorem 10.4.1, the general solution of (10.4.8) is

$$\mathbf{y} = c_1 \mathbf{y}_1 + c_2 \mathbf{y}_2 = c_1 \begin{bmatrix} 1 \\ 1 \end{bmatrix} e^{6t} + c_2 \begin{bmatrix} -1 \\ 1 \end{bmatrix} e^{-2t}. \quad (10.4.11)$$

**SOLUTION(b)** To satisfy the initial condition in (10.4.9), we must choose  $c_1$  and  $c_2$  in (10.4.11) so that

$$c_1 \begin{bmatrix} 1 \\ 1 \end{bmatrix} + c_2 \begin{bmatrix} -1 \\ 1 \end{bmatrix} = \begin{bmatrix} 5 \\ -1 \end{bmatrix}.$$

This is equivalent to the system

$$\begin{aligned} c_1 - c_2 &= 5 \\ c_1 + c_2 &= -1, \end{aligned}$$

so  $c_1 = 2$ ,  $c_2 = -3$ . Therefore the solution of (10.4.9) is

$$\mathbf{y} = 2 \begin{bmatrix} 1 \\ 1 \end{bmatrix} e^{6t} - 3 \begin{bmatrix} -1 \\ 1 \end{bmatrix} e^{-2t},$$

or, in terms of components,

$$y_1 = 2e^{6t} + 3e^{-2t}, \quad y_2 = 2e^{6t} - 3e^{-2t}.$$

### Example 10.4.2

(a) Find the general solution of

$$\mathbf{y}' = \begin{bmatrix} 3 & -1 & -1 \\ -2 & 3 & 2 \\ 4 & -1 & -2 \end{bmatrix} \mathbf{y}. \quad (10.4.12)$$

(b) Solve the initial value problem

$$\mathbf{y}' = \begin{bmatrix} 3 & -1 & -1 \\ -2 & 3 & 2 \\ 4 & -1 & -2 \end{bmatrix} \mathbf{y}, \quad \mathbf{y}(0) = \begin{bmatrix} 2 \\ -1 \\ 8 \end{bmatrix}. \quad (10.4.13)$$

**SOLUTION(a)** The characteristic polynomial of the coefficient matrix  $A$  in (10.4.12) is

$$\begin{vmatrix} 3 - \lambda & -1 & -1 \\ -2 & 3 - \lambda & 2 \\ 4 & -1 & -2 - \lambda \end{vmatrix} = -(\lambda - 2)(\lambda - 3)(\lambda + 1).$$

Hence, the eigenvalues of  $A$  are  $\lambda_1 = 2$ ,  $\lambda_2 = 3$ , and  $\lambda_3 = -1$ . To find the eigenvectors, we must solve the system

$$\begin{bmatrix} 3 - \lambda & -1 & -1 \\ -2 & 3 - \lambda & 2 \\ 4 & -1 & -2 - \lambda \end{bmatrix} \begin{bmatrix} x_1 \\ x_2 \\ x_3 \end{bmatrix} = \begin{bmatrix} 0 \\ 0 \\ 0 \end{bmatrix} \quad (10.4.14)$$

with  $\lambda = 2, 3, -1$ . With  $\lambda = 2$ , the augmented matrix of (10.4.14) is

$$\begin{bmatrix} 1 & -1 & -1 & \vdots & 0 \\ -2 & 1 & 2 & \vdots & 0 \\ 4 & -1 & -4 & \vdots & 0 \end{bmatrix},$$

which is row equivalent to

$$\begin{bmatrix} 1 & 0 & -1 & \vdots & 0 \\ 0 & 1 & 0 & \vdots & 0 \\ 0 & 0 & 0 & \vdots & 0 \end{bmatrix}.$$

Hence,  $x_1 = x_3$  and  $x_2 = 0$ . Taking  $x_3 = 1$  yields

$$\mathbf{y}_1 = \begin{bmatrix} 1 \\ 0 \\ 1 \end{bmatrix} e^{2t}$$

as a solution of (10.4.12). With  $\lambda = 3$ , the augmented matrix of (10.4.14) is

$$\begin{bmatrix} 0 & -1 & -1 & \vdots & 0 \\ -2 & 0 & 2 & \vdots & 0 \\ 4 & -1 & -5 & \vdots & 0 \end{bmatrix},$$

which is row equivalent to

$$\begin{bmatrix} 1 & 0 & -1 & \vdots & 0 \\ 0 & 1 & 1 & \vdots & 0 \\ 0 & 0 & 0 & \vdots & 0 \end{bmatrix}.$$

Hence,  $x_1 = x_3$  and  $x_2 = -x_3$ . Taking  $x_3 = 1$  yields

$$\mathbf{y}_2 = \begin{bmatrix} 1 \\ -1 \\ 1 \end{bmatrix} e^{3t}$$

as a solution of (10.4.12). With  $\lambda = -1$ , the augmented matrix of (10.4.14) is

$$\begin{bmatrix} 4 & -1 & -1 & \vdots & 0 \\ -2 & 4 & 2 & \vdots & 0 \\ 4 & -1 & -1 & \vdots & 0 \end{bmatrix},$$

which is row equivalent to

$$\begin{bmatrix} 1 & 0 & -\frac{1}{7} & \vdots & 0 \\ 0 & 1 & \frac{3}{7} & \vdots & 0 \\ 0 & 0 & 0 & \vdots & 0 \end{bmatrix}.$$

Hence,  $x_1 = x_3/7$  and  $x_2 = -3x_3/7$ . Taking  $x_3 = 7$  yields

$$\mathbf{y}_3 = \begin{bmatrix} 1 \\ -3 \\ 7 \end{bmatrix} e^{-t}$$

as a solution of (10.4.12). By Theorem 10.4.1, the general solution of (10.4.12) is

$$\mathbf{y} = c_1 \begin{bmatrix} 1 \\ 0 \\ 1 \end{bmatrix} e^{2t} + c_2 \begin{bmatrix} 1 \\ -1 \\ 1 \end{bmatrix} e^{3t} + c_3 \begin{bmatrix} 1 \\ -3 \\ 7 \end{bmatrix} e^{-t},$$

which can also be written as

$$\mathbf{y} = \begin{bmatrix} e^{2t} & e^{3t} & e^{-t} \\ 0 & -e^{3t} & -3e^{-t} \\ e^{2t} & e^{3t} & 7e^{-t} \end{bmatrix} \begin{bmatrix} c_1 \\ c_2 \\ c_3 \end{bmatrix}. \quad (10.4.15)$$

**SOLUTION(b)** To satisfy the initial condition in (10.4.13) we must choose  $c_1, c_2, c_3$  in (10.4.15) so that

$$\begin{bmatrix} 1 & 1 & 1 \\ 0 & -1 & -3 \\ 1 & 1 & 7 \end{bmatrix} \begin{bmatrix} c_1 \\ c_2 \\ c_3 \end{bmatrix} = \begin{bmatrix} 2 \\ -1 \\ 8 \end{bmatrix}.$$

Solving this system yields  $c_1 = 3, c_2 = -2, c_3 = 1$ . Hence, the solution of (10.4.13) is

$$\begin{aligned} \mathbf{y} &= \begin{bmatrix} e^{2t} & e^{3t} & e^{-t} \\ 0 & -e^{3t} & -3e^{-t} \\ e^{2t} & e^{3t} & 7e^{-t} \end{bmatrix} \begin{bmatrix} 3 \\ -2 \\ 1 \end{bmatrix} \\ &= 3 \begin{bmatrix} 1 \\ 0 \\ 1 \end{bmatrix} e^{2t} - 2 \begin{bmatrix} 1 \\ -1 \\ 1 \end{bmatrix} e^{3t} + \begin{bmatrix} 1 \\ -3 \\ 7 \end{bmatrix} e^{-t}. \end{aligned}$$

**Example 10.4.3** Find the general solution of

$$\mathbf{y}' = \begin{bmatrix} -3 & 2 & 2 \\ 2 & -3 & 2 \\ 2 & 2 & -3 \end{bmatrix} \mathbf{y}. \quad (10.4.16)$$

**Solution** The characteristic polynomial of the coefficient matrix  $A$  in (10.4.16) is

$$\begin{vmatrix} -3 - \lambda & 2 & 2 \\ 2 & -3 - \lambda & 2 \\ 2 & 2 & -3 - \lambda \end{vmatrix} = -(\lambda - 1)(\lambda + 5)^2.$$

Hence,  $\lambda_1 = 1$  is an eigenvalue of multiplicity 1, while  $\lambda_2 = -5$  is an eigenvalue of multiplicity 2. Eigenvectors associated with  $\lambda_1 = 1$  are solutions of the system with augmented matrix

$$\begin{bmatrix} -4 & 2 & 2 & \vdots & 0 \\ 2 & -4 & 2 & \vdots & 0 \\ 2 & 2 & -4 & \vdots & 0 \end{bmatrix},$$

which is row equivalent to

$$\begin{bmatrix} 1 & 0 & -1 & \vdots & 0 \\ 0 & 1 & -1 & \vdots & 0 \\ 0 & 0 & 0 & \vdots & 0 \end{bmatrix}.$$

Hence,  $x_1 = x_2 = x_3$ , and we choose  $x_3 = 1$  to obtain the solution

$$\mathbf{y}_1 = \begin{bmatrix} 1 \\ 1 \\ 1 \end{bmatrix} e^t \quad (10.4.17)$$

of (10.4.16). Eigenvectors associated with  $\lambda_2 = -5$  are solutions of the system with augmented matrix

$$\begin{bmatrix} 2 & 2 & 2 & \vdots & 0 \\ 2 & 2 & 2 & \vdots & 0 \\ 2 & 2 & 2 & \vdots & 0 \end{bmatrix}.$$

Hence, the components of these eigenvectors need only satisfy the single condition

$$x_1 + x_2 + x_3 = 0.$$

Since there's only one equation here, we can choose  $x_2$  and  $x_3$  arbitrarily. We obtain one eigenvector by choosing  $x_2 = 0$  and  $x_3 = 1$ , and another by choosing  $x_2 = 1$  and  $x_3 = 0$ . In both cases  $x_1 = -1$ . Therefore

$$\begin{bmatrix} -1 \\ 0 \\ 1 \end{bmatrix} \quad \text{and} \quad \begin{bmatrix} -1 \\ 1 \\ 0 \end{bmatrix}$$

are linearly independent eigenvectors associated with  $\lambda_2 = -5$ , and the corresponding solutions of (10.4.16) are

$$\mathbf{y}_2 = \begin{bmatrix} -1 \\ 0 \\ 1 \end{bmatrix} e^{-5t} \quad \text{and} \quad \mathbf{y}_3 = \begin{bmatrix} -1 \\ 1 \\ 0 \end{bmatrix} e^{-5t}.$$

Because of this and (10.4.17), Theorem 10.4.1 implies that the general solution of (10.4.16) is

$$\mathbf{y} = c_1 \begin{bmatrix} 1 \\ 1 \\ 1 \end{bmatrix} e^t + c_2 \begin{bmatrix} -1 \\ 0 \\ 1 \end{bmatrix} e^{-5t} + c_3 \begin{bmatrix} -1 \\ 1 \\ 0 \end{bmatrix} e^{-5t}.$$

### Geometric Properties of Solutions when $n = 2$

We'll now consider the geometric properties of solutions of a  $2 \times 2$  constant coefficient system

$$\begin{bmatrix} y_1' \\ y_2' \end{bmatrix} = \begin{bmatrix} a_{11} & a_{12} \\ a_{21} & a_{22} \end{bmatrix} \begin{bmatrix} y_1 \\ y_2 \end{bmatrix}. \quad (10.4.18)$$

It is convenient to think of a " $y_1$ - $y_2$  plane," where a point is identified by rectangular coordinates  $(y_1, y_2)$ .

If  $\mathbf{y} = \begin{bmatrix} y_1 \\ y_2 \end{bmatrix}$  is a non-constant solution of (10.4.18), then the point  $(y_1(t), y_2(t))$  moves along a curve  $C$  in the  $y_1$ - $y_2$  plane as  $t$  varies from  $-\infty$  to  $\infty$ . We call  $C$  the *trajectory* of  $\mathbf{y}$ . (We also say that  $C$  is a trajectory of the system (10.4.18).) It's important to note that  $C$  is the trajectory of infinitely many solutions of (10.4.18), since if  $\tau$  is any real number, then  $\mathbf{y}(t - \tau)$  is a solution of (10.4.18) (Exercise 28(b)), and  $(y_1(t - \tau), y_2(t - \tau))$  also moves along  $C$  as  $t$  varies from  $-\infty$  to  $\infty$ . Moreover, Exercise 28(c) implies that distinct trajectories of (10.4.18) can't intersect, and that two solutions  $\mathbf{y}_1$  and  $\mathbf{y}_2$  of (10.4.18) have the same trajectory if and only if  $\mathbf{y}_2(t) = \mathbf{y}_1(t - \tau)$  for some  $\tau$ .

From Exercise 28(a), a trajectory of a nontrivial solution of (10.4.18) can't contain  $(0, 0)$ , which we define to be the trajectory of the trivial solution  $\mathbf{y} \equiv \mathbf{0}$ . More generally, if  $\mathbf{y} = \begin{bmatrix} k_1 \\ k_2 \end{bmatrix} \neq \mathbf{0}$  is a constant solution of (10.4.18) (which could occur if zero is an eigenvalue of the matrix of (10.4.18)), we define the trajectory of  $\mathbf{y}$  to be the single point  $(k_1, k_2)$ .

To be specific, this is the question: What do the trajectories look like, and how are they traversed? In this section we'll answer this question, assuming that the matrix

$$A = \begin{bmatrix} a_{11} & a_{12} \\ a_{21} & a_{22} \end{bmatrix}$$

of (10.4.18) has real eigenvalues  $\lambda_1$  and  $\lambda_2$  with associated linearly independent eigenvectors  $\mathbf{x}_1$  and  $\mathbf{x}_2$ . Then the general solution of (10.4.18) is

$$\mathbf{y} = c_1 \mathbf{x}_1 e^{\lambda_1 t} + c_2 \mathbf{x}_2 e^{\lambda_2 t}. \quad (10.4.19)$$

We'll consider other situations in the next two sections.

We leave it to you (Exercise 35) to classify the trajectories of (10.4.18) if zero is an eigenvalue of  $A$ . We'll confine our attention here to the case where both eigenvalues are nonzero. In this case the simplest situation is where  $\lambda_1 = \lambda_2 \neq 0$ , so (10.4.19) becomes

$$\mathbf{y} = (c_1 \mathbf{x}_1 + c_2 \mathbf{x}_2) e^{\lambda_1 t}.$$

Since  $\mathbf{x}_1$  and  $\mathbf{x}_2$  are linearly independent, an arbitrary vector  $\mathbf{x}$  can be written as  $\mathbf{x} = c_1 \mathbf{x}_1 + c_2 \mathbf{x}_2$ . Therefore the general solution of (10.4.18) can be written as  $\mathbf{y} = \mathbf{x} e^{\lambda_1 t}$  where  $\mathbf{x}$  is an arbitrary 2-vector, and the trajectories of nontrivial solutions of (10.4.18) are half-lines through (but not including)

the origin. The direction of motion is away from the origin if  $\lambda_1 > 0$  (Figure 10.4.1), toward it if  $\lambda_1 < 0$  (Figure 10.4.2). (In these and the next figures an arrow through a point indicates the direction of motion along the trajectory through the point.)

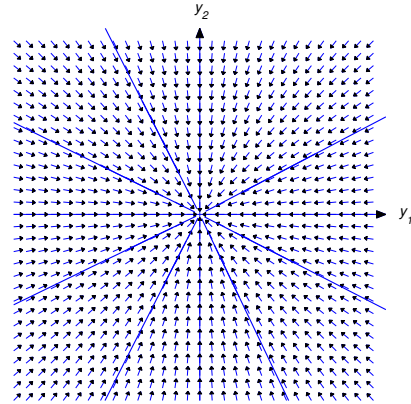
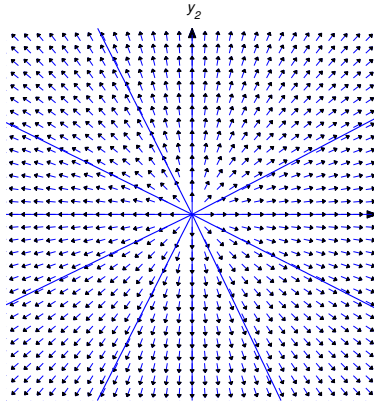

Figure 10.4.1 Trajectories of a  $2 \times 2$  system with a repeated positive eigenvalue

Figure 10.4.2 Trajectories of a  $2 \times 2$  system with a repeated negative eigenvalue

Now suppose  $\lambda_2 > \lambda_1$ , and let  $L_1$  and  $L_2$  denote lines through the origin parallel to  $\mathbf{x}_1$  and  $\mathbf{x}_2$ , respectively. By a half-line of  $L_1$  (or  $L_2$ ), we mean either of the rays obtained by removing the origin from  $L_1$  (or  $L_2$ ).

Letting  $c_2 = 0$  in (10.4.19) yields  $\mathbf{y} = c_1 \mathbf{x}_1 e^{\lambda_1 t}$ . If  $c_1 \neq 0$ , the trajectory defined by this solution is a half-line of  $L_1$ . The direction of motion is away from the origin if  $\lambda_1 > 0$ , toward the origin if  $\lambda_1 < 0$ . Similarly, the trajectory of  $\mathbf{y} = c_2 \mathbf{x}_2 e^{\lambda_2 t}$  with  $c_2 \neq 0$  is a half-line of  $L_2$ .

Henceforth, we assume that  $c_1$  and  $c_2$  in (10.4.19) are both nonzero. In this case, the trajectory of (10.4.19) can't intersect  $L_1$  or  $L_2$ , since every point on these lines is on the trajectory of a solution for which either  $c_1 = 0$  or  $c_2 = 0$ . (Remember: distinct trajectories can't intersect!). Therefore the trajectory of (10.4.19) must lie entirely in one of the four open sectors bounded by  $L_1$  and  $L_2$ , but do not any point on  $L_1$  or  $L_2$ . Since the initial point  $(y_1(0), y_2(0))$  defined by

$$\mathbf{y}(0) = c_1 \mathbf{x}_1 + c_2 \mathbf{x}_2$$

is on the trajectory, we can determine which sector contains the trajectory from the signs of  $c_1$  and  $c_2$ , as shown in Figure 10.4.3.

The direction of  $\mathbf{y}(t)$  in (10.4.19) is the same as that of

$$e^{-\lambda_2 t} \mathbf{y}(t) = c_1 \mathbf{x}_1 e^{-(\lambda_2 - \lambda_1)t} + c_2 \mathbf{x}_2 \tag{10.4.20}$$

and of

$$e^{-\lambda_1 t} \mathbf{y}(t) = c_1 \mathbf{x}_1 + c_2 \mathbf{x}_2 e^{(\lambda_2 - \lambda_1)t}. \tag{10.4.21}$$

Since the right side of (10.4.20) approaches  $c_2 \mathbf{x}_2$  as  $t \rightarrow \infty$ , the trajectory is asymptotically parallel to  $L_2$  as  $t \rightarrow \infty$ . Since the right side of (10.4.21) approaches  $c_1 \mathbf{x}_1$  as  $t \rightarrow -\infty$ , the trajectory is asymptotically parallel to  $L_1$  as  $t \rightarrow -\infty$ .

The shape and direction of traversal of the trajectory of (10.4.19) depend upon whether  $\lambda_1$  and  $\lambda_2$  are both positive, both negative, or of opposite signs. We'll now analyze these three cases.

Henceforth  $\|\mathbf{u}\|$  denote the length of the vector  $\mathbf{u}$ .



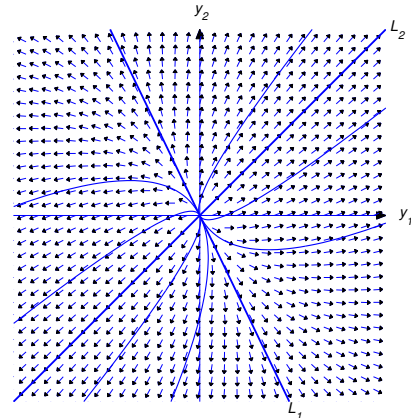
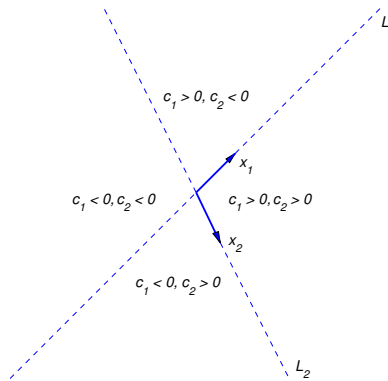

Figure 10.4.3 Four open sectors bounded by  $L_1$  and  $L_2$       Figure 10.4.4 Two positive eigenvalues; motion away from origin

**Case 1:  $\lambda_2 > \lambda_1 > 0$**

Figure 10.4.4 shows some typical trajectories. In this case,  $\lim_{t \rightarrow -\infty} \|\mathbf{y}(t)\| = 0$ , so the trajectory is not only asymptotically parallel to  $L_1$  as  $t \rightarrow -\infty$ , but is actually asymptotically tangent to  $L_1$  at the origin. On the other hand,  $\lim_{t \rightarrow \infty} \|\mathbf{y}(t)\| = \infty$  and

$$\lim_{t \rightarrow \infty} \|\mathbf{y}(t) - c_2 \mathbf{x}_2 e^{\lambda_2 t}\| = \lim_{t \rightarrow \infty} \|c_1 \mathbf{x}_1 e^{\lambda_1 t}\| = \infty,$$

so, although the trajectory is asymptotically parallel to  $L_2$  as  $t \rightarrow \infty$ , it's not asymptotically tangent to  $L_2$ . The direction of motion along each trajectory is away from the origin.

**Case 2:  $0 > \lambda_2 > \lambda_1$**

Figure 10.4.5 shows some typical trajectories. In this case,  $\lim_{t \rightarrow \infty} \|\mathbf{y}(t)\| = 0$ , so the trajectory is asymptotically tangent to  $L_2$  at the origin as  $t \rightarrow \infty$ . On the other hand,  $\lim_{t \rightarrow -\infty} \|\mathbf{y}(t)\| = \infty$  and

$$\lim_{t \rightarrow -\infty} \|\mathbf{y}(t) - c_1 \mathbf{x}_1 e^{\lambda_1 t}\| = \lim_{t \rightarrow -\infty} \|c_2 \mathbf{x}_2 e^{\lambda_2 t}\| = \infty,$$

so, although the trajectory is asymptotically parallel to  $L_1$  as  $t \rightarrow -\infty$ , it's not asymptotically tangent to it. The direction of motion along each trajectory is toward the origin.

**Case 3:  $\lambda_2 > 0 > \lambda_1$**

Figure 10.4.6 shows some typical trajectories. In this case,

$$\lim_{t \rightarrow \infty} \|\mathbf{y}(t)\| = \infty \quad \text{and} \quad \lim_{t \rightarrow \infty} \|\mathbf{y}(t) - c_2 \mathbf{x}_2 e^{\lambda_2 t}\| = \lim_{t \rightarrow \infty} \|c_1 \mathbf{x}_1 e^{\lambda_1 t}\| = 0,$$

so the trajectory is asymptotically tangent to  $L_2$  as  $t \rightarrow \infty$ . Similarly,

$$\lim_{t \rightarrow -\infty} \|\mathbf{y}(t)\| = \infty \quad \text{and} \quad \lim_{t \rightarrow -\infty} \|\mathbf{y}(t) - c_1 \mathbf{x}_1 e^{\lambda_1 t}\| = \lim_{t \rightarrow -\infty} \|c_2 \mathbf{x}_2 e^{\lambda_2 t}\| = 0,$$

so the trajectory is asymptotically tangent to  $L_1$  as  $t \rightarrow -\infty$ . The direction of motion is toward the origin on  $L_1$  and away from the origin on  $L_2$ . The direction of motion along any other trajectory is away from  $L_1$ , toward  $L_2$ .

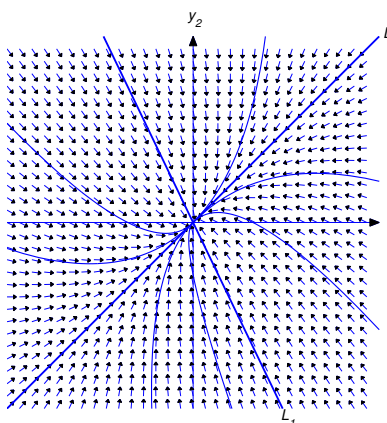

Figure 10.4.5 Two negative eigenvalues; motion toward the origin

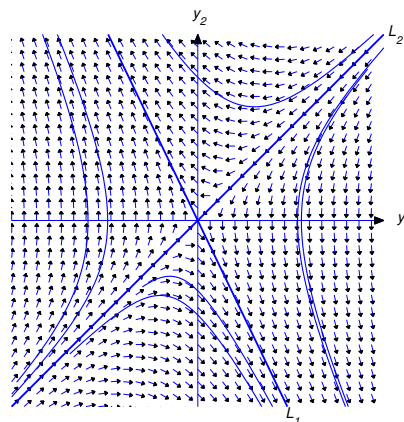

Figure 10.4.6 Eigenvalues of different signs

### 10.4 Exercises

In Exercises 1–15 find the general solution.

$$1. \quad \mathbf{y}' = \begin{bmatrix} 1 & 2 \\ 2 & 1 \end{bmatrix} \mathbf{y}$$

$$2. \quad \mathbf{y}' = \frac{1}{4} \begin{bmatrix} -5 & 3 \\ 3 & -5 \end{bmatrix} \mathbf{y}$$

$$3. \quad \mathbf{y}' = \frac{1}{5} \begin{bmatrix} -4 & 3 \\ -2 & -11 \end{bmatrix} \mathbf{y}$$

$$4. \quad \mathbf{y}' = \begin{bmatrix} -1 & -4 \\ -1 & -1 \end{bmatrix} \mathbf{y}$$

$$5. \quad \mathbf{y}' = \begin{bmatrix} 2 & -4 \\ -1 & -1 \end{bmatrix} \mathbf{y}$$

$$6. \quad \mathbf{y}' = \begin{bmatrix} 4 & -3 \\ 2 & -1 \end{bmatrix} \mathbf{y}$$

$$7. \quad \mathbf{y}' = \begin{bmatrix} -6 & -3 \\ 1 & -2 \end{bmatrix} \mathbf{y}$$

$$8. \quad \mathbf{y}' = \begin{bmatrix} 1 & -1 & -2 \\ 1 & -2 & -3 \\ -4 & 1 & -1 \end{bmatrix} \mathbf{y}$$

$$9. \quad \mathbf{y}' = \begin{bmatrix} -6 & -4 & -8 \\ -4 & 0 & -4 \\ -8 & -4 & -6 \end{bmatrix} \mathbf{y}$$

$$10. \quad \mathbf{y}' = \begin{bmatrix} 3 & 5 & 8 \\ 1 & -1 & -2 \\ -1 & -1 & -1 \end{bmatrix} \mathbf{y}$$

$$11. \quad \mathbf{y}' = \begin{bmatrix} 1 & -1 & 2 \\ 12 & -4 & 10 \\ -6 & 1 & -7 \end{bmatrix} \mathbf{y}$$

$$12. \quad \mathbf{y}' = \begin{bmatrix} 4 & -1 & -4 \\ 4 & -3 & -2 \\ 1 & -1 & -1 \end{bmatrix} \mathbf{y}$$

$$13. \quad \mathbf{y}' = \begin{bmatrix} -2 & 2 & -6 \\ 2 & 6 & 2 \\ -2 & -2 & 2 \end{bmatrix} \mathbf{y}$$

$$14. \quad \mathbf{y}' = \begin{bmatrix} 3 & 2 & -2 \\ -2 & 7 & -2 \\ -10 & 10 & -5 \end{bmatrix} \mathbf{y}$$

$$15. \quad \mathbf{y}' = \begin{bmatrix} 3 & 1 & -1 \\ 3 & 5 & 1 \\ -6 & 2 & 4 \end{bmatrix} \mathbf{y}$$

In Exercises 16–27 solve the initial value problem.

$$16. \quad \mathbf{y}' = \begin{bmatrix} -7 & 4 \\ -6 & 7 \end{bmatrix} \mathbf{y}, \quad \mathbf{y}(0) = \begin{bmatrix} 2 \\ -4 \end{bmatrix}$$

$$17. \quad \mathbf{y}' = \frac{1}{6} \begin{bmatrix} 7 & 2 \\ -2 & 2 \end{bmatrix} \mathbf{y}, \quad \mathbf{y}(0) = \begin{bmatrix} 0 \\ -3 \end{bmatrix}$$

$$18. \quad \mathbf{y}' = \begin{bmatrix} 21 & -12 \\ 24 & -15 \end{bmatrix} \mathbf{y}, \quad \mathbf{y}(0) = \begin{bmatrix} 5 \\ 3 \end{bmatrix}$$

$$19. \quad \mathbf{y}' = \begin{bmatrix} -7 & 4 \\ -6 & 7 \end{bmatrix} \mathbf{y}, \quad \mathbf{y}(0) = \begin{bmatrix} -1 \\ 7 \end{bmatrix}$$

$$20. \quad \mathbf{y}' = \frac{1}{6} \begin{bmatrix} 1 & 2 & 0 \\ 4 & -1 & 0 \\ 0 & 0 & 3 \end{bmatrix} \mathbf{y}, \quad \mathbf{y}(0) = \begin{bmatrix} 4 \\ 7 \\ 1 \end{bmatrix}$$

$$21. \quad \mathbf{y}' = \frac{1}{3} \begin{bmatrix} 2 & -2 & 3 \\ -4 & 4 & 3 \\ 2 & 1 & 0 \end{bmatrix} \mathbf{y}, \quad \mathbf{y}(0) = \begin{bmatrix} 1 \\ 1 \\ 5 \end{bmatrix}$$

$$22. \quad \mathbf{y}' = \begin{bmatrix} 6 & -3 & -8 \\ 2 & 1 & -2 \\ 3 & -3 & -5 \end{bmatrix} \mathbf{y}, \quad \mathbf{y}(0) = \begin{bmatrix} 0 \\ -1 \\ -1 \end{bmatrix}$$

$$23. \quad \mathbf{y}' = \frac{1}{3} \begin{bmatrix} 2 & 4 & -7 \\ 1 & 5 & -5 \\ -4 & 4 & -1 \end{bmatrix} \mathbf{y}, \quad \mathbf{y}(0) = \begin{bmatrix} 4 \\ 1 \\ 3 \end{bmatrix}$$

$$24. \quad \mathbf{y}' = \begin{bmatrix} 3 & 0 & 1 \\ 11 & -2 & 7 \\ 1 & 0 & 3 \end{bmatrix} \mathbf{y}, \quad \mathbf{y}(0) = \begin{bmatrix} 2 \\ 7 \\ 6 \end{bmatrix}$$

$$25. \quad \mathbf{y}' = \begin{bmatrix} -2 & -5 & -1 \\ -4 & -1 & 1 \\ 4 & 5 & 3 \end{bmatrix} \mathbf{y}, \quad \mathbf{y}(0) = \begin{bmatrix} 8 \\ -10 \\ -4 \end{bmatrix}$$

$$26. \quad \mathbf{y}' = \begin{bmatrix} 3 & -1 & 0 \\ 4 & -2 & 0 \\ 4 & -4 & 2 \end{bmatrix} \mathbf{y}, \quad \mathbf{y}(0) = \begin{bmatrix} 7 \\ 10 \\ 2 \end{bmatrix}$$

$$27. \quad \mathbf{y}' = \begin{bmatrix} -2 & 2 & 6 \\ 2 & 6 & 2 \\ -2 & -2 & 2 \end{bmatrix} \mathbf{y}, \quad \mathbf{y}(0) = \begin{bmatrix} 6 \\ -10 \\ 7 \end{bmatrix}$$

28. Let  $A$  be an  $n \times n$  constant matrix. Then Theorem 10.2.1 implies that the solutions of

$$\mathbf{y}' = A\mathbf{y} \tag{A}$$

are all defined on  $(-\infty, \infty)$ .

- (a) Use Theorem 10.2.1 to show that the only solution of (A) that can ever equal the zero vector is  $\mathbf{y} \equiv \mathbf{0}$ .

- (b) Suppose  $\mathbf{y}_1$  is a solution of (A) and  $\mathbf{y}_2$  is defined by  $\mathbf{y}_2(t) = \mathbf{y}_1(t - \tau)$ , where  $\tau$  is an arbitrary real number. Show that  $\mathbf{y}_2$  is also a solution of (A).
- (c) Suppose  $\mathbf{y}_1$  and  $\mathbf{y}_2$  are solutions of (A) and there are real numbers  $t_1$  and  $t_2$  such that  $\mathbf{y}_1(t_1) = \mathbf{y}_2(t_2)$ . Show that  $\mathbf{y}_2(t) = \mathbf{y}_1(t - \tau)$  for all  $t$ , where  $\tau = t_2 - t_1$ . HINT: Show that  $\mathbf{y}_1(t - \tau)$  and  $\mathbf{y}_2(t)$  are solutions of the same initial value problem for (A), and apply the uniqueness assertion of Theorem 10.2.1.

In Exercises 29–34 describe and graph trajectories of the given system.

29.  $\boxed{\text{C/G}}$   $\mathbf{y}' = \begin{bmatrix} 1 & 1 \\ 1 & -1 \end{bmatrix} \mathbf{y}$

30.  $\boxed{\text{C/G}}$   $\mathbf{y}' = \begin{bmatrix} -4 & 3 \\ -2 & -11 \end{bmatrix} \mathbf{y}$

31.  $\boxed{\text{C/G}}$   $\mathbf{y}' = \begin{bmatrix} 9 & -3 \\ -1 & 11 \end{bmatrix} \mathbf{y}$

32.  $\boxed{\text{C/G}}$   $\mathbf{y}' = \begin{bmatrix} -1 & -10 \\ -5 & 4 \end{bmatrix} \mathbf{y}$

33.  $\boxed{\text{C/G}}$   $\mathbf{y}' = \begin{bmatrix} 5 & -4 \\ 1 & 10 \end{bmatrix} \mathbf{y}$

34.  $\boxed{\text{C/G}}$   $\mathbf{y}' = \begin{bmatrix} -7 & 1 \\ 3 & -5 \end{bmatrix} \mathbf{y}$

35. Suppose the eigenvalues of the  $2 \times 2$  matrix  $A$  are  $\lambda = 0$  and  $\mu \neq 0$ , with corresponding eigenvectors  $\mathbf{x}_1$  and  $\mathbf{x}_2$ . Let  $L_1$  be the line through the origin parallel to  $\mathbf{x}_1$ .

- (a) Show that every point on  $L_1$  is the trajectory of a constant solution of  $\mathbf{y}' = A\mathbf{y}$ .
- (b) Show that the trajectories of nonconstant solutions of  $\mathbf{y}' = A\mathbf{y}$  are half-lines parallel to  $\mathbf{x}_2$  and on either side of  $L_1$ , and that the direction of motion along these trajectories is away from  $L_1$  if  $\mu > 0$ , or toward  $L_1$  if  $\mu < 0$ .

The matrices of the systems in Exercises 36–41 are singular. Describe and graph the trajectories of nonconstant solutions of the given systems.

36.  $\boxed{\text{C/G}}$   $\mathbf{y}' = \begin{bmatrix} -1 & 1 \\ 1 & -1 \end{bmatrix} \mathbf{y}$

37.  $\boxed{\text{C/G}}$   $\mathbf{y}' = \begin{bmatrix} -1 & -3 \\ 2 & 6 \end{bmatrix} \mathbf{y}$

38.  $\boxed{\text{C/G}}$   $\mathbf{y}' = \begin{bmatrix} 1 & -3 \\ -1 & 3 \end{bmatrix} \mathbf{y}$

39.  $\boxed{\text{C/G}}$   $\mathbf{y}' = \begin{bmatrix} 1 & -2 \\ -1 & 2 \end{bmatrix} \mathbf{y}$

40.  $\boxed{\text{C/G}}$   $\mathbf{y}' = \begin{bmatrix} -4 & -4 \\ 1 & 1 \end{bmatrix} \mathbf{y}$

41.  $\boxed{\text{C/G}}$   $\mathbf{y}' = \begin{bmatrix} 3 & -1 \\ -3 & 1 \end{bmatrix} \mathbf{y}$

42.  $\boxed{\text{L}}$  Let  $P = P(t)$  and  $Q = Q(t)$  be the populations of two species at time  $t$ , and assume that each population would grow exponentially if the other didn't exist; that is, in the absence of competition,

$$P' = aP \quad \text{and} \quad Q' = bQ, \quad (\text{A})$$

where  $a$  and  $b$  are positive constants. One way to model the effect of competition is to assume that the growth rate per individual of each population is reduced by an amount proportional to the other population, so (A) is replaced by

$$\begin{aligned} P' &= aP - \alpha Q \\ Q' &= -\beta P + bQ, \end{aligned}$$

where  $\alpha$  and  $\beta$  are positive constants. (Since negative population doesn't make sense, this system holds only while  $P$  and  $Q$  are both positive.) Now suppose  $P(0) = P_0 > 0$  and  $Q(0) = Q_0 > 0$ .

- (a) For several choices of  $a$ ,  $b$ ,  $\alpha$ , and  $\beta$ , verify experimentally (by graphing trajectories of (A) in the  $P$ - $Q$  plane) that there's a constant  $\rho > 0$  (depending upon  $a$ ,  $b$ ,  $\alpha$ , and  $\beta$ ) with the following properties:
- (i) If  $Q_0 > \rho P_0$ , then  $P$  decreases monotonically to zero in finite time, during which  $Q$  remains positive.
  - (ii) If  $Q_0 < \rho P_0$ , then  $Q$  decreases monotonically to zero in finite time, during which  $P$  remains positive.
- (b) Conclude from (a) that exactly one of the species becomes extinct in finite time if  $Q_0 \neq \rho P_0$ . Determine experimentally what happens if  $Q_0 = \rho P_0$ .
- (c) Confirm your experimental results and determine  $\gamma$  by expressing the eigenvalues and associated eigenvectors of

$$A = \begin{bmatrix} a & -\alpha \\ -\beta & b \end{bmatrix}$$

in terms of  $a$ ,  $b$ ,  $\alpha$ , and  $\beta$ , and applying the geometric arguments developed at the end of this section.

## 10.5 CONSTANT COEFFICIENT HOMOGENEOUS SYSTEMS II

We saw in Section 10.4 that if an  $n \times n$  constant matrix  $A$  has  $n$  real eigenvalues  $\lambda_1, \lambda_2, \dots, \lambda_n$  (which need not be distinct) with associated linearly independent eigenvectors  $\mathbf{x}_1, \mathbf{x}_2, \dots, \mathbf{x}_n$ , then the general solution of  $\mathbf{y}' = A\mathbf{y}$  is

$$\mathbf{y} = c_1\mathbf{x}_1e^{\lambda_1 t} + c_2\mathbf{x}_2e^{\lambda_2 t} + \dots + c_n\mathbf{x}_ne^{\lambda_n t}.$$

In this section we consider the case where  $A$  has  $n$  real eigenvalues, but does not have  $n$  linearly independent eigenvectors. It is shown in linear algebra that this occurs if and only if  $A$  has at least one eigenvalue of multiplicity  $r > 1$  such that the associated eigenspace has dimension less than  $r$ . In this case  $A$  is said to be *defective*. Since it's beyond the scope of this book to give a complete analysis of systems with defective coefficient matrices, we will restrict our attention to some commonly occurring special cases.

**Example 10.5.1** Show that the system

$$\mathbf{y}' = \begin{bmatrix} 11 & -25 \\ 4 & -9 \end{bmatrix} \mathbf{y} \quad (10.5.1)$$

does not have a fundamental set of solutions of the form  $\{\mathbf{x}_1e^{\lambda_1 t}, \mathbf{x}_2e^{\lambda_2 t}\}$ , where  $\lambda_1$  and  $\lambda_2$  are eigenvalues of the coefficient matrix  $A$  of (10.5.1) and  $\mathbf{x}_1$ , and  $\mathbf{x}_2$  are associated linearly independent eigenvectors.

**Solution** The characteristic polynomial of  $A$  is

$$\begin{aligned} \begin{vmatrix} 11 - \lambda & -25 \\ 4 & -9 - \lambda \end{vmatrix} &= (\lambda - 11)(\lambda + 9) + 100 \\ &= \lambda^2 - 2\lambda + 1 = (\lambda - 1)^2. \end{aligned}$$

Hence,  $\lambda = 1$  is the only eigenvalue of  $A$ . The augmented matrix of the system  $(A - I)\mathbf{x} = \mathbf{0}$  is

$$\begin{bmatrix} 10 & -25 & \vdots & 0 \\ 4 & -10 & \vdots & 0 \end{bmatrix},$$

which is row equivalent to

$$\begin{bmatrix} 1 & -\frac{5}{2} & \vdots & 0 \\ 0 & 0 & \vdots & 0 \end{bmatrix}.$$

Hence,  $x_1 = 5x_2/2$  where  $x_2$  is arbitrary. Therefore all eigenvectors of  $A$  are scalar multiples of  $\mathbf{x}_1 = \begin{bmatrix} 5 \\ 2 \end{bmatrix}$ , so  $A$  does not have a set of two linearly independent eigenvectors. ■

From Example 10.5.1, we know that all scalar multiples of  $\mathbf{y}_1 = \begin{bmatrix} 5 \\ 2 \end{bmatrix} e^t$  are solutions of (10.5.1); however, to find the general solution we must find a second solution  $\mathbf{y}_2$  such that  $\{\mathbf{y}_1, \mathbf{y}_2\}$  is linearly independent. Based on your recollection of the procedure for solving a constant coefficient scalar equation

$$ay'' + by' + cy = 0$$

in the case where the characteristic polynomial has a repeated root, you might expect to obtain a second solution of (10.5.1) by multiplying the first solution by  $t$ . However, this yields  $\mathbf{y}_2 = \begin{bmatrix} 5 \\ 2 \end{bmatrix} te^t$ , which doesn't work, since

$$\mathbf{y}'_2 = \begin{bmatrix} 5 \\ 2 \end{bmatrix} (te^t + e^t), \quad \text{while} \quad \begin{bmatrix} 11 & -25 \\ 4 & -9 \end{bmatrix} \mathbf{y}_2 = \begin{bmatrix} 5 \\ 2 \end{bmatrix} te^t.$$

The next theorem shows what to do in this situation.

**Theorem 10.5.1** *Suppose the  $n \times n$  matrix  $A$  has an eigenvalue  $\lambda_1$  of multiplicity  $\geq 2$  and the associated eigenspace has dimension 1; that is, all  $\lambda_1$ -eigenvectors of  $A$  are scalar multiples of an eigenvector  $\mathbf{x}$ . Then there are infinitely many vectors  $\mathbf{u}$  such that*

$$(A - \lambda_1 I)\mathbf{u} = \mathbf{x}. \tag{10.5.2}$$

Moreover, if  $\mathbf{u}$  is any such vector then

$$\mathbf{y}_1 = \mathbf{x}e^{\lambda_1 t} \quad \text{and} \quad \mathbf{y}_2 = \mathbf{u}e^{\lambda_1 t} + \mathbf{x}te^{\lambda_1 t} \tag{10.5.3}$$

are linearly independent solutions of  $\mathbf{y}' = A\mathbf{y}$ .

A complete proof of this theorem is beyond the scope of this book. The difficulty is in proving that there's a vector  $\mathbf{u}$  satisfying (10.5.2), since  $\det(A - \lambda_1 I) = 0$ . We'll take this without proof and verify the other assertions of the theorem.

We already know that  $\mathbf{y}_1$  in (10.5.3) is a solution of  $\mathbf{y}' = A\mathbf{y}$ . To see that  $\mathbf{y}_2$  is also a solution, we compute

$$\begin{aligned} \mathbf{y}'_2 - A\mathbf{y}_2 &= \lambda_1 \mathbf{u}e^{\lambda_1 t} + \mathbf{x}e^{\lambda_1 t} + \lambda_1 \mathbf{x}te^{\lambda_1 t} - A\mathbf{u}e^{\lambda_1 t} - A\mathbf{x}te^{\lambda_1 t} \\ &= (\lambda_1 \mathbf{u} + \mathbf{x} - A\mathbf{u})e^{\lambda_1 t} + (\lambda_1 \mathbf{x} - A\mathbf{x})te^{\lambda_1 t}. \end{aligned}$$

Since  $A\mathbf{x} = \lambda_1 \mathbf{x}$ , this can be written as

$$\mathbf{y}'_2 - A\mathbf{y}_2 = -((A - \lambda_1 I)\mathbf{u} - \mathbf{x})e^{\lambda_1 t},$$

and now (10.5.2) implies that  $\mathbf{y}'_2 = A\mathbf{y}_2$ .

To see that  $\mathbf{y}_1$  and  $\mathbf{y}_2$  are linearly independent, suppose  $c_1$  and  $c_2$  are constants such that

$$c_1\mathbf{y}_1 + c_2\mathbf{y}_2 = c_1\mathbf{x}e^{\lambda_1 t} + c_2(\mathbf{u}e^{\lambda_1 t} + \mathbf{x}te^{\lambda_1 t}) = \mathbf{0}. \quad (10.5.4)$$

We must show that  $c_1 = c_2 = 0$ . Multiplying (10.5.4) by  $e^{-\lambda_1 t}$  shows that

$$c_1\mathbf{x} + c_2(\mathbf{u} + \mathbf{x}t) = \mathbf{0}. \quad (10.5.5)$$

By differentiating this with respect to  $t$ , we see that  $c_2\mathbf{x} = \mathbf{0}$ , which implies  $c_2 = 0$ , because  $\mathbf{x} \neq \mathbf{0}$ . Substituting  $c_2 = 0$  into (10.5.5) yields  $c_1\mathbf{x} = \mathbf{0}$ , which implies that  $c_1 = 0$ , again because  $\mathbf{x} \neq \mathbf{0}$ .

**Example 10.5.2** Use Theorem 10.5.1 to find the general solution of the system

$$\mathbf{y}' = \begin{bmatrix} 11 & -25 \\ 4 & -9 \end{bmatrix} \mathbf{y} \quad (10.5.6)$$

considered in Example 10.5.1.

**Solution** In Example 10.5.1 we saw that  $\lambda_1 = 1$  is an eigenvalue of multiplicity 2 of the coefficient matrix  $A$  in (10.5.6), and that all of the eigenvectors of  $A$  are multiples of

$$\mathbf{x} = \begin{bmatrix} 5 \\ 2 \end{bmatrix}.$$

Therefore

$$\mathbf{y}_1 = \begin{bmatrix} 5 \\ 2 \end{bmatrix} e^t$$

is a solution of (10.5.6). From Theorem 10.5.1, a second solution is given by  $\mathbf{y}_2 = \mathbf{u}e^t + \mathbf{x}te^t$ , where  $(A - I)\mathbf{u} = \mathbf{x}$ . The augmented matrix of this system is

$$\left[ \begin{array}{ccc|c} 10 & -25 & \vdots & 5 \\ 4 & -10 & \vdots & 2 \end{array} \right],$$

which is row equivalent to

$$\left[ \begin{array}{ccc|c} 1 & -\frac{5}{2} & \vdots & \frac{1}{2} \\ 0 & 0 & \vdots & 0 \end{array} \right].$$

Therefore the components of  $\mathbf{u}$  must satisfy

$$u_1 - \frac{5}{2}u_2 = \frac{1}{2},$$

where  $u_2$  is arbitrary. We choose  $u_2 = 0$ , so that  $u_1 = 1/2$  and

$$\mathbf{u} = \begin{bmatrix} \frac{1}{2} \\ 0 \end{bmatrix}.$$

Thus,

$$\mathbf{y}_2 = \begin{bmatrix} 1 \\ 0 \end{bmatrix} \frac{e^t}{2} + \begin{bmatrix} 5 \\ 2 \end{bmatrix} te^t.$$

Since  $\mathbf{y}_1$  and  $\mathbf{y}_2$  are linearly independent by Theorem 10.5.1, they form a fundamental set of solutions of (10.5.6). Therefore the general solution of (10.5.6) is

$$\mathbf{y} = c_1 \begin{bmatrix} 5 \\ 2 \end{bmatrix} e^t + c_2 \left( \begin{bmatrix} 1 \\ 0 \end{bmatrix} \frac{e^t}{2} + \begin{bmatrix} 5 \\ 2 \end{bmatrix} t e^t \right). \blacksquare$$

Note that choosing the arbitrary constant  $u_2$  to be nonzero is equivalent to adding a scalar multiple of  $\mathbf{y}_1$  to the second solution  $\mathbf{y}_2$  (Exercise 33).

**Example 10.5.3** Find the general solution of

$$\mathbf{y}' = \begin{bmatrix} 3 & 4 & -10 \\ 2 & 1 & -2 \\ 2 & 2 & -5 \end{bmatrix} \mathbf{y}. \quad (10.5.7)$$

**Solution** The characteristic polynomial of the coefficient matrix  $A$  in (10.5.7) is

$$\begin{vmatrix} 3 - \lambda & 4 & -10 \\ 2 & 1 - \lambda & -2 \\ 2 & 2 & -5 - \lambda \end{vmatrix} = -(\lambda - 1)(\lambda + 1)^2.$$

Hence, the eigenvalues are  $\lambda_1 = 1$  with multiplicity 1 and  $\lambda_2 = -1$  with multiplicity 2.

Eigenvectors associated with  $\lambda_1 = 1$  must satisfy  $(A - I)\mathbf{x} = \mathbf{0}$ . The augmented matrix of this system is

$$\begin{bmatrix} 2 & 4 & -10 & \vdots & 0 \\ 2 & 0 & -2 & \vdots & 0 \\ 2 & 2 & -6 & \vdots & 0 \end{bmatrix},$$

which is row equivalent to

$$\begin{bmatrix} 1 & 0 & -1 & \vdots & 0 \\ 0 & 1 & -2 & \vdots & 0 \\ 0 & 0 & 0 & \vdots & 0 \end{bmatrix}.$$

Hence,  $x_1 = x_3$  and  $x_2 = 2x_3$ , where  $x_3$  is arbitrary. Choosing  $x_3 = 1$  yields the eigenvector

$$\mathbf{x}_1 = \begin{bmatrix} 1 \\ 2 \\ 1 \end{bmatrix}.$$

Therefore

$$\mathbf{y}_1 = \begin{bmatrix} 1 \\ 2 \\ 1 \end{bmatrix} e^t$$

is a solution of (10.5.7).

Eigenvectors associated with  $\lambda_2 = -1$  satisfy  $(A + I)\mathbf{x} = \mathbf{0}$ . The augmented matrix of this system is

$$\begin{bmatrix} 4 & 4 & -10 & \vdots & 0 \\ 2 & 2 & -2 & \vdots & 0 \\ 2 & 2 & -4 & \vdots & 0 \end{bmatrix},$$



which is row equivalent to

$$\begin{bmatrix} 1 & 1 & 0 & \vdots & 0 \\ 0 & 0 & 1 & \vdots & 0 \\ 0 & 0 & 0 & \vdots & 0 \end{bmatrix}.$$

Hence,  $x_3 = 0$  and  $x_1 = -x_2$ , where  $x_2$  is arbitrary. Choosing  $x_2 = 1$  yields the eigenvector

$$\mathbf{x}_2 = \begin{bmatrix} -1 \\ 1 \\ 0 \end{bmatrix},$$

so

$$\mathbf{y}_2 = \begin{bmatrix} -1 \\ 1 \\ 0 \end{bmatrix} e^{-t}$$

is a solution of (10.5.7).

Since all the eigenvectors of  $A$  associated with  $\lambda_2 = -1$  are multiples of  $\mathbf{x}_2$ , we must now use Theorem 10.5.1 to find a third solution of (10.5.7) in the form

$$\mathbf{y}_3 = \mathbf{u}e^{-t} + \begin{bmatrix} -1 \\ 1 \\ 0 \end{bmatrix} te^{-t}, \quad (10.5.8)$$

where  $\mathbf{u}$  is a solution of  $(A + I)\mathbf{u} = \mathbf{x}_2$ . The augmented matrix of this system is

$$\begin{bmatrix} 4 & 4 & -10 & \vdots & -1 \\ 2 & 2 & -2 & \vdots & 1 \\ 2 & 2 & -4 & \vdots & 0 \end{bmatrix},$$

which is row equivalent to

$$\begin{bmatrix} 1 & 1 & 0 & \vdots & 1 \\ 0 & 0 & 1 & \vdots & \frac{1}{2} \\ 0 & 0 & 0 & \vdots & 0 \end{bmatrix}.$$

Hence,  $u_3 = 1/2$  and  $u_1 = 1 - u_2$ , where  $u_2$  is arbitrary. Choosing  $u_2 = 0$  yields

$$\mathbf{u} = \begin{bmatrix} 1 \\ 0 \\ \frac{1}{2} \end{bmatrix},$$

and substituting this into (10.5.8) yields the solution

$$\mathbf{y}_3 = \begin{bmatrix} 2 \\ 0 \\ 1 \end{bmatrix} \frac{e^{-t}}{2} + \begin{bmatrix} -1 \\ 1 \\ 0 \end{bmatrix} te^{-t}$$

of (10.5.7).

Since the Wronskian of  $\{\mathbf{y}_1, \mathbf{y}_2, \mathbf{y}_3\}$  at  $t = 0$  is

$$\begin{vmatrix} 1 & -1 & 1 \\ 2 & 1 & 0 \\ 1 & 0 & \frac{1}{2} \end{vmatrix} = \frac{1}{2},$$

$\{\mathbf{y}_1, \mathbf{y}_2, \mathbf{y}_3\}$  is a fundamental set of solutions of (10.5.7). Therefore the general solution of (10.5.7) is

$$\mathbf{y} = c_1 \begin{bmatrix} 1 \\ 2 \\ 1 \end{bmatrix} e^t + c_2 \begin{bmatrix} -1 \\ 1 \\ 0 \end{bmatrix} e^{-t} + c_3 \left( \begin{bmatrix} 2 \\ 0 \\ 1 \end{bmatrix} \frac{e^{-t}}{2} + \begin{bmatrix} -1 \\ 1 \\ 0 \end{bmatrix} t e^{-t} \right).$$

**Theorem 10.5.2** Suppose the  $n \times n$  matrix  $A$  has an eigenvalue  $\lambda_1$  of multiplicity  $\geq 3$  and the associated eigenspace is one-dimensional; that is, all eigenvectors associated with  $\lambda_1$  are scalar multiples of the eigenvector  $\mathbf{x}$ . Then there are infinitely many vectors  $\mathbf{u}$  such that

$$(A - \lambda_1 I)\mathbf{u} = \mathbf{x}, \quad (10.5.9)$$

and, if  $\mathbf{u}$  is any such vector, there are infinitely many vectors  $\mathbf{v}$  such that

$$(A - \lambda_1 I)\mathbf{v} = \mathbf{u}. \quad (10.5.10)$$

If  $\mathbf{u}$  satisfies (10.5.9) and  $\mathbf{v}$  satisfies (10.5.10), then

$$\begin{aligned} \mathbf{y}_1 &= \mathbf{x}e^{\lambda_1 t}, \\ \mathbf{y}_2 &= \mathbf{u}e^{\lambda_1 t} + \mathbf{x}te^{\lambda_1 t}, \text{ and} \\ \mathbf{y}_3 &= \mathbf{v}e^{\lambda_1 t} + \mathbf{u}te^{\lambda_1 t} + \mathbf{x}\frac{t^2 e^{\lambda_1 t}}{2} \end{aligned}$$

are linearly independent solutions of  $\mathbf{y}' = A\mathbf{y}$ .

Again, it's beyond the scope of this book to prove that there are vectors  $\mathbf{u}$  and  $\mathbf{v}$  that satisfy (10.5.9) and (10.5.10). Theorem 10.5.1 implies that  $\mathbf{y}_1$  and  $\mathbf{y}_2$  are solutions of  $\mathbf{y}' = A\mathbf{y}$ . We leave the rest of the proof to you (Exercise 34).

**Example 10.5.4** Use Theorem 10.5.2 to find the general solution of

$$\mathbf{y}' = \begin{bmatrix} 1 & 1 & 1 \\ 1 & 3 & -1 \\ 0 & 2 & 2 \end{bmatrix} \mathbf{y}. \quad (10.5.11)$$

**Solution** The characteristic polynomial of the coefficient matrix  $A$  in (10.5.11) is

$$\begin{vmatrix} 1 - \lambda & 1 & 1 \\ 1 & 3 - \lambda & -1 \\ 0 & 2 & 2 - \lambda \end{vmatrix} = -(\lambda - 2)^3.$$

Hence,  $\lambda_1 = 2$  is an eigenvalue of multiplicity 3. The associated eigenvectors satisfy  $(A - 2I)\mathbf{x} = \mathbf{0}$ . The augmented matrix of this system is

$$\begin{bmatrix} -1 & 1 & 1 & \vdots & 0 \\ 1 & 1 & -1 & \vdots & 0 \\ 0 & 2 & 0 & \vdots & 0 \end{bmatrix},$$

which is row equivalent to

$$\begin{bmatrix} 1 & 0 & -1 & \vdots & 0 \\ 0 & 1 & 0 & \vdots & 0 \\ 0 & 0 & 0 & \vdots & 0 \end{bmatrix}.$$

Hence,  $x_1 = x_3$  and  $x_2 = 0$ , so the eigenvectors are all scalar multiples of

$$\mathbf{x}_1 = \begin{bmatrix} 1 \\ 0 \\ 1 \end{bmatrix}.$$

Therefore

$$\mathbf{y}_1 = \begin{bmatrix} 1 \\ 0 \\ 1 \end{bmatrix} e^{2t}$$

is a solution of (10.5.11).

We now find a second solution of (10.5.11) in the form

$$\mathbf{y}_2 = \mathbf{u}e^{2t} + \begin{bmatrix} 1 \\ 0 \\ 1 \end{bmatrix} te^{2t},$$

where  $\mathbf{u}$  satisfies  $(A - 2I)\mathbf{u} = \mathbf{x}_1$ . The augmented matrix of this system is

$$\begin{bmatrix} -1 & 1 & 1 & \vdots & 1 \\ 1 & 1 & -1 & \vdots & 0 \\ 0 & 2 & 0 & \vdots & 1 \end{bmatrix},$$

which is row equivalent to

$$\begin{bmatrix} 1 & 0 & -1 & \vdots & -\frac{1}{2} \\ 0 & 1 & 0 & \vdots & \frac{1}{2} \\ 0 & 0 & 0 & \vdots & 0 \end{bmatrix}.$$

Letting  $u_3 = 0$  yields  $u_1 = -1/2$  and  $u_2 = 1/2$ ; hence,

$$\mathbf{u} = \frac{1}{2} \begin{bmatrix} -1 \\ 1 \\ 0 \end{bmatrix}$$

and

$$\mathbf{y}_2 = \begin{bmatrix} -1 \\ 1 \\ 0 \end{bmatrix} \frac{e^{2t}}{2} + \begin{bmatrix} 1 \\ 0 \\ 1 \end{bmatrix} te^{2t}$$

is a solution of (10.5.11).

We now find a third solution of (10.5.11) in the form

$$\mathbf{y}_3 = \mathbf{v}e^{2t} + \begin{bmatrix} -1 \\ 1 \\ 0 \end{bmatrix} \frac{te^{2t}}{2} + \begin{bmatrix} 1 \\ 0 \\ 1 \end{bmatrix} \frac{t^2e^{2t}}{2}$$

where  $\mathbf{v}$  satisfies  $(A - 2I)\mathbf{v} = \mathbf{u}$ . The augmented matrix of this system is

$$\left[ \begin{array}{cccc|c} -1 & 1 & 1 & \vdots & -\frac{1}{2} \\ 1 & 1 & -1 & \vdots & \frac{1}{2} \\ 0 & 2 & 0 & \vdots & 0 \end{array} \right],$$

which is row equivalent to

$$\left[ \begin{array}{cccc|c} 1 & 0 & -1 & \vdots & \frac{1}{2} \\ 0 & 1 & 0 & \vdots & 0 \\ 0 & 0 & 0 & \vdots & 0 \end{array} \right].$$

Letting  $v_3 = 0$  yields  $v_1 = 1/2$  and  $v_2 = 0$ ; hence,

$$\mathbf{v} = \frac{1}{2} \begin{bmatrix} 1 \\ 0 \\ 0 \end{bmatrix}.$$

Therefore

$$\mathbf{y}_3 = \begin{bmatrix} 1 \\ 0 \\ 0 \end{bmatrix} \frac{e^{2t}}{2} + \begin{bmatrix} -1 \\ 1 \\ 0 \end{bmatrix} \frac{te^{2t}}{2} + \begin{bmatrix} 1 \\ 0 \\ 1 \end{bmatrix} \frac{t^2e^{2t}}{2}$$

is a solution of (10.5.11). Since  $\mathbf{y}_1$ ,  $\mathbf{y}_2$ , and  $\mathbf{y}_3$  are linearly independent by Theorem 10.5.2, they form a fundamental set of solutions of (10.5.11). Therefore the general solution of (10.5.11) is

$$\begin{aligned} \mathbf{y} = & c_1 \begin{bmatrix} 1 \\ 0 \\ 1 \end{bmatrix} e^{2t} + c_2 \left( \begin{bmatrix} -1 \\ 1 \\ 0 \end{bmatrix} \frac{e^{2t}}{2} + \begin{bmatrix} 1 \\ 0 \\ 1 \end{bmatrix} te^{2t} \right) \\ & + c_3 \left( \begin{bmatrix} 1 \\ 0 \\ 0 \end{bmatrix} \frac{e^{2t}}{2} + \begin{bmatrix} -1 \\ 1 \\ 0 \end{bmatrix} \frac{te^{2t}}{2} + \begin{bmatrix} 1 \\ 0 \\ 1 \end{bmatrix} \frac{t^2e^{2t}}{2} \right). \end{aligned}$$

**Theorem 10.5.3** Suppose the  $n \times n$  matrix  $A$  has an eigenvalue  $\lambda_1$  of multiplicity  $\geq 3$  and the associated eigenspace is two-dimensional; that is, all eigenvectors of  $A$  associated with  $\lambda_1$  are linear combinations of two linearly independent eigenvectors  $\mathbf{x}_1$  and  $\mathbf{x}_2$ . Then there are constants  $\alpha$  and  $\beta$  (not both zero) such that if

$$\mathbf{x}_3 = \alpha\mathbf{x}_1 + \beta\mathbf{x}_2, \quad (10.5.12)$$

then there are infinitely many vectors  $\mathbf{u}$  such that

$$(A - \lambda_1 I)\mathbf{u} = \mathbf{x}_3. \quad (10.5.13)$$

If  $\mathbf{u}$  satisfies (10.5.13), then

$$\begin{aligned} \mathbf{y}_1 &= \mathbf{x}_1 e^{\lambda_1 t}, \\ \mathbf{y}_2 &= \mathbf{x}_2 e^{\lambda_1 t}, \text{ and} \\ \mathbf{y}_3 &= \mathbf{u} e^{\lambda_1 t} + \mathbf{x}_3 t e^{\lambda_1 t}, \end{aligned} \quad (10.5.14)$$

are linearly independent solutions of  $\mathbf{y}' = A\mathbf{y}$ .

We omit the proof of this theorem.

**Example 10.5.5** Use Theorem 10.5.3 to find the general solution of

$$\mathbf{y}' = \begin{bmatrix} 0 & 0 & 1 \\ -1 & 1 & 1 \\ -1 & 0 & 2 \end{bmatrix} \mathbf{y}. \quad (10.5.15)$$

**Solution** The characteristic polynomial of the coefficient matrix  $A$  in (10.5.15) is

$$\begin{vmatrix} -\lambda & 0 & 1 \\ -1 & 1-\lambda & 1 \\ -1 & 0 & 2-\lambda \end{vmatrix} = -(\lambda-1)^3.$$

Hence,  $\lambda_1 = 1$  is an eigenvalue of multiplicity 3. The associated eigenvectors satisfy  $(A - I)\mathbf{x} = \mathbf{0}$ . The augmented matrix of this system is

$$\begin{bmatrix} -1 & 0 & 1 & \vdots & 0 \\ -1 & 0 & 1 & \vdots & 0 \\ -1 & 0 & 1 & \vdots & 0 \end{bmatrix},$$

which is row equivalent to

$$\begin{bmatrix} 1 & 0 & -1 & \vdots & 0 \\ 0 & 0 & 0 & \vdots & 0 \\ 0 & 0 & 0 & \vdots & 0 \end{bmatrix}.$$

Hence,  $x_1 = x_3$  and  $x_2$  is arbitrary, so the eigenvectors are of the form

$$\mathbf{x}_1 = \begin{bmatrix} x_3 \\ x_2 \\ x_3 \end{bmatrix} = x_3 \begin{bmatrix} 1 \\ 0 \\ 1 \end{bmatrix} + x_2 \begin{bmatrix} 0 \\ 1 \\ 0 \end{bmatrix}.$$

Therefore the vectors

$$\mathbf{x}_1 = \begin{bmatrix} 1 \\ 0 \\ 1 \end{bmatrix} \quad \text{and} \quad \mathbf{x}_2 = \begin{bmatrix} 0 \\ 1 \\ 0 \end{bmatrix} \quad (10.5.16)$$

form a basis for the eigenspace, and

$$\mathbf{y}_1 = \begin{bmatrix} 1 \\ 0 \\ 1 \end{bmatrix} e^t \quad \text{and} \quad \mathbf{y}_2 = \begin{bmatrix} 0 \\ 1 \\ 0 \end{bmatrix} e^t$$

are linearly independent solutions of (10.5.15).

To find a third linearly independent solution of (10.5.15), we must find constants  $\alpha$  and  $\beta$  (not both zero) such that the system

$$(A - I)\mathbf{u} = \alpha\mathbf{x}_1 + \beta\mathbf{x}_2 \quad (10.5.17)$$

has a solution  $\mathbf{u}$ . The augmented matrix of this system is

$$\begin{bmatrix} -1 & 0 & 1 & \vdots & \alpha \\ -1 & 0 & 1 & \vdots & \beta \\ -1 & 0 & 1 & \vdots & \alpha \end{bmatrix},$$

which is row equivalent to

$$\begin{bmatrix} 1 & 0 & -1 & \vdots & -\alpha \\ 0 & 0 & 0 & \vdots & \beta - \alpha \\ 0 & 0 & 0 & \vdots & 0 \end{bmatrix}. \quad (10.5.18)$$

Therefore (10.5.17) has a solution if and only if  $\beta = \alpha$ , where  $\alpha$  is arbitrary. If  $\alpha = \beta = 1$  then (10.5.12) and (10.5.16) yield

$$\mathbf{x}_3 = \mathbf{x}_1 + \mathbf{x}_2 = \begin{bmatrix} 1 \\ 0 \\ 1 \end{bmatrix} + \begin{bmatrix} 0 \\ 1 \\ 0 \end{bmatrix} = \begin{bmatrix} 1 \\ 1 \\ 1 \end{bmatrix},$$

and the augmented matrix (10.5.18) becomes

$$\begin{bmatrix} 1 & 0 & -1 & \vdots & -1 \\ 0 & 0 & 0 & \vdots & 0 \\ 0 & 0 & 0 & \vdots & 0 \end{bmatrix}.$$

This implies that  $u_1 = -1 + u_3$ , while  $u_2$  and  $u_3$  are arbitrary. Choosing  $u_2 = u_3 = 0$  yields

$$\mathbf{u} = \begin{bmatrix} -1 \\ 0 \\ 0 \end{bmatrix}.$$

Therefore (10.5.14) implies that

$$\mathbf{y}_3 = \mathbf{u}e^t + \mathbf{x}_3te^t = \begin{bmatrix} -1 \\ 0 \\ 0 \end{bmatrix} e^t + \begin{bmatrix} 1 \\ 1 \\ 1 \end{bmatrix} te^t$$

is a solution of (10.5.15). Since  $\mathbf{y}_1$ ,  $\mathbf{y}_2$ , and  $\mathbf{y}_3$  are linearly independent by Theorem 10.5.3, they form a fundamental set of solutions for (10.5.15). Therefore the general solution of (10.5.15) is

$$\mathbf{y} = c_1 \begin{bmatrix} 1 \\ 0 \\ 1 \end{bmatrix} e^t + c_2 \begin{bmatrix} 0 \\ 1 \\ 0 \end{bmatrix} e^t + c_3 \left( \begin{bmatrix} -1 \\ 0 \\ 0 \end{bmatrix} e^t + \begin{bmatrix} 1 \\ 1 \\ 1 \end{bmatrix} te^t \right). \blacksquare$$

### Geometric Properties of Solutions when $n = 2$

We'll now consider the geometric properties of solutions of a  $2 \times 2$  constant coefficient system

$$\begin{bmatrix} y_1' \\ y_2' \end{bmatrix} = \begin{bmatrix} a_{11} & a_{12} \\ a_{21} & a_{22} \end{bmatrix} \begin{bmatrix} y_1 \\ y_2 \end{bmatrix} \quad (10.5.19)$$

under the assumptions of this section; that is, when the matrix

$$A = \begin{bmatrix} a_{11} & a_{12} \\ a_{21} & a_{22} \end{bmatrix}$$

has a repeated eigenvalue  $\lambda_1$  and the associated eigenspace is one-dimensional. In this case we know from Theorem 10.5.1 that the general solution of (10.5.19) is

$$\mathbf{y} = c_1 \mathbf{x}e^{\lambda_1 t} + c_2 (\mathbf{u}e^{\lambda_1 t} + \mathbf{x}te^{\lambda_1 t}), \quad (10.5.20)$$

where  $\mathbf{x}$  is an eigenvector of  $A$  and  $\mathbf{u}$  is any one of the infinitely many solutions of

$$(A - \lambda_1 I)\mathbf{u} = \mathbf{x}. \quad (10.5.21)$$

We assume that  $\lambda_1 \neq 0$ .

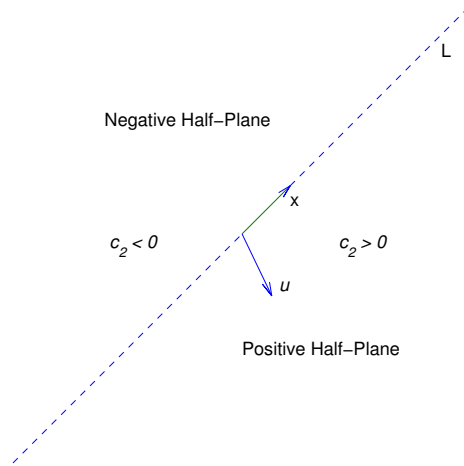

Figure 10.5.1 Positive and negative half-planes

Let  $L$  denote the line through the origin parallel to  $\mathbf{x}$ . By a *half-line* of  $L$  we mean either of the rays obtained by removing the origin from  $L$ . Eqn. (10.5.20) is a parametric equation of the half-line of  $L$  in the direction of  $\mathbf{x}$  if  $c_1 > 0$ , or of the half-line of  $L$  in the direction of  $-\mathbf{x}$  if  $c_1 < 0$ . The origin is the trajectory of the trivial solution  $\mathbf{y} \equiv \mathbf{0}$ .

Henceforth, we assume that  $c_2 \neq 0$ . In this case, the trajectory of (10.5.20) can't intersect  $L$ , since every point of  $L$  is on a trajectory obtained by setting  $c_2 = 0$ . Therefore the trajectory of (10.5.20) must lie entirely in one of the open half-planes bounded by  $L$ , but does not contain any point on  $L$ . Since the initial point  $(y_1(0), y_2(0))$  defined by  $\mathbf{y}(0) = c_1\mathbf{x}_1 + c_2\mathbf{u}$  is on the trajectory, we can determine which half-plane contains the trajectory from the sign of  $c_2$ , as shown in Figure 552. For convenience we'll call the half-plane where  $c_2 > 0$  the *positive half-plane*. Similarly, the half-plane where  $c_2 < 0$  is the *negative half-plane*. You should convince yourself (Exercise 35) that even though there are infinitely many vectors  $\mathbf{u}$  that satisfy (10.5.21), they all define the same positive and negative half-planes. In the figures simply regard  $\mathbf{u}$  as an arrow pointing to the positive half-plane, since we've attempted to give  $\mathbf{u}$  its proper length or direction in comparison with  $\mathbf{x}$ . For our purposes here, only the relative orientation of  $\mathbf{x}$  and  $\mathbf{u}$  is important; that is, whether the positive half-plane is to the right of an observer facing the direction of  $\mathbf{x}$  (as in Figures 10.5.2 and 10.5.5), or to the left of the observer (as in Figures 10.5.3 and 10.5.4).

Multiplying (10.5.20) by  $e^{-\lambda_1 t}$  yields

$$e^{-\lambda_1 t}\mathbf{y}(t) = c_1\mathbf{x} + c_2\mathbf{u} + c_2t\mathbf{x}.$$

Since the last term on the right is dominant when  $|t|$  is large, this provides the following information on the direction of  $\mathbf{y}(t)$ :

- (a) Along trajectories in the positive half-plane ( $c_2 > 0$ ), the direction of  $\mathbf{y}(t)$  approaches the direction of  $\mathbf{x}$  as  $t \rightarrow \infty$  and the direction of  $-\mathbf{x}$  as  $t \rightarrow -\infty$ .
- (b) Along trajectories in the negative half-plane ( $c_2 < 0$ ), the direction of  $\mathbf{y}(t)$  approaches the direction of  $-\mathbf{x}$  as  $t \rightarrow \infty$  and the direction of  $\mathbf{x}$  as  $t \rightarrow -\infty$ .

Since

$$\lim_{t \rightarrow \infty} \|\mathbf{y}(t)\| = \infty \quad \text{and} \quad \lim_{t \rightarrow -\infty} \mathbf{y}(t) = \mathbf{0} \quad \text{if} \quad \lambda_1 > 0,$$

or

$$\lim_{t \rightarrow -\infty} \|\mathbf{y}(t)\| = \infty \quad \text{and} \quad \lim_{t \rightarrow \infty} \mathbf{y}(t) = \mathbf{0} \quad \text{if} \quad \lambda_1 < 0,$$

there are four possible patterns for the trajectories of (10.5.19), depending upon the signs of  $c_2$  and  $\lambda_1$ . Figures 10.5.2-10.5.5 illustrate these patterns, and reveal the following principle:

*If  $\lambda_1$  and  $c_2$  have the same sign then the direction of the trajectory approaches the direction of  $-\mathbf{x}$  as  $\|\mathbf{y}\| \rightarrow 0$  and the direction of  $\mathbf{x}$  as  $\|\mathbf{y}\| \rightarrow \infty$ . If  $\lambda_1$  and  $c_2$  have opposite signs then the direction of the trajectory approaches the direction of  $\mathbf{x}$  as  $\|\mathbf{y}\| \rightarrow 0$  and the direction of  $-\mathbf{x}$  as  $\|\mathbf{y}\| \rightarrow \infty$ .*

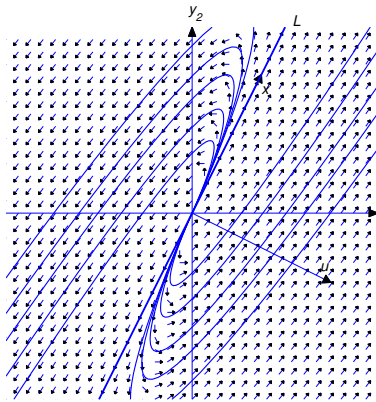

Figure 10.5.2 Positive eigenvalue; motion away from the origin

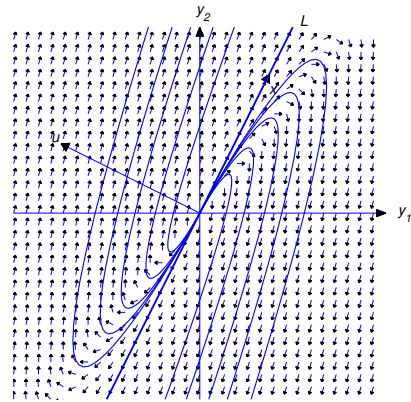

Figure 10.5.3 Positive eigenvalue; motion away from the origin

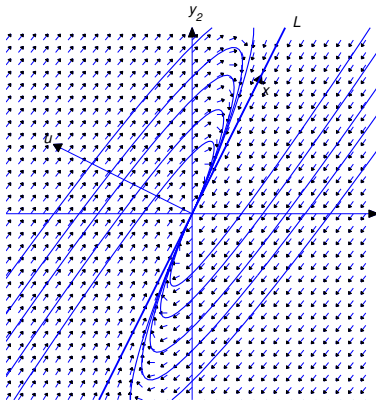

Figure 10.5.4 Negative eigenvalue; motion toward the origin

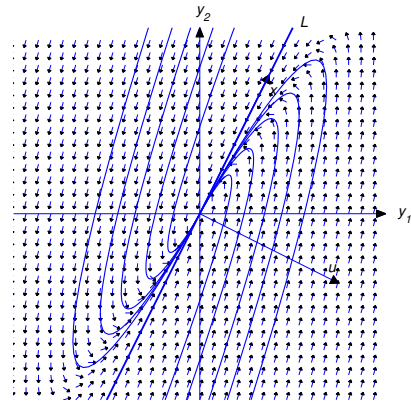

Figure 10.5.5 Negative eigenvalue; motion toward the origin



### 10.5 Exercises

In Exercises 1–12 find the general solution.

$$1. \quad \mathbf{y}' = \begin{bmatrix} 3 & 4 \\ -1 & 7 \end{bmatrix} \mathbf{y}$$

$$2. \quad \mathbf{y}' = \begin{bmatrix} 0 & -1 \\ 1 & -2 \end{bmatrix} \mathbf{y}$$

$$3. \quad \mathbf{y}' = \begin{bmatrix} -7 & 4 \\ -1 & -11 \end{bmatrix} \mathbf{y}$$

$$4. \quad \mathbf{y}' = \begin{bmatrix} 3 & 1 \\ -1 & 1 \end{bmatrix} \mathbf{y}$$

$$5. \quad \mathbf{y}' = \begin{bmatrix} 4 & 12 \\ -3 & -8 \end{bmatrix} \mathbf{y}$$

$$6. \quad \mathbf{y}' = \begin{bmatrix} -10 & 9 \\ -4 & 2 \end{bmatrix} \mathbf{y}$$

$$7. \quad \mathbf{y}' = \begin{bmatrix} -13 & 16 \\ -9 & 11 \end{bmatrix} \mathbf{y}$$

$$8. \quad \mathbf{y}' = \begin{bmatrix} 0 & 2 & 1 \\ -4 & 6 & 1 \\ 0 & 4 & 2 \end{bmatrix} \mathbf{y}$$

$$9. \quad \mathbf{y}' = \frac{1}{3} \begin{bmatrix} 1 & 1 & -3 \\ -4 & -4 & 3 \\ -2 & 1 & 0 \end{bmatrix} \mathbf{y}$$

$$10. \quad \mathbf{y}' = \begin{bmatrix} -1 & 1 & -1 \\ -2 & 0 & 2 \\ -1 & 3 & -1 \end{bmatrix} \mathbf{y}$$

$$11. \quad \mathbf{y}' = \begin{bmatrix} 4 & -2 & -2 \\ -2 & 3 & -1 \\ 2 & -1 & 3 \end{bmatrix} \mathbf{y}$$

$$12. \quad \mathbf{y}' = \begin{bmatrix} 6 & -5 & 3 \\ 2 & -1 & 3 \\ 2 & 1 & 1 \end{bmatrix} \mathbf{y}$$

In Exercises 13–23 solve the initial value problem.

$$13. \quad \mathbf{y}' = \begin{bmatrix} -11 & 8 \\ -2 & -3 \end{bmatrix} \mathbf{y}, \quad \mathbf{y}(0) = \begin{bmatrix} 6 \\ 2 \end{bmatrix}$$

$$14. \quad \mathbf{y}' = \begin{bmatrix} 15 & -9 \\ 16 & -9 \end{bmatrix} \mathbf{y}, \quad \mathbf{y}(0) = \begin{bmatrix} 5 \\ 8 \end{bmatrix}$$

$$15. \quad \mathbf{y}' = \begin{bmatrix} -3 & -4 \\ 1 & -7 \end{bmatrix} \mathbf{y}, \quad \mathbf{y}(0) = \begin{bmatrix} 2 \\ 3 \end{bmatrix}$$

$$16. \quad \mathbf{y}' = \begin{bmatrix} -7 & 24 \\ -6 & 17 \end{bmatrix} \mathbf{y}, \quad \mathbf{y}(0) = \begin{bmatrix} 3 \\ 1 \end{bmatrix}$$

$$17. \quad \mathbf{y}' = \begin{bmatrix} -7 & 3 \\ -3 & -1 \end{bmatrix} \mathbf{y}, \quad \mathbf{y}(0) = \begin{bmatrix} 0 \\ 2 \end{bmatrix}$$

$$18. \quad \mathbf{y}' = \begin{bmatrix} -1 & 1 & 0 \\ 1 & -1 & -2 \\ -1 & -1 & -1 \end{bmatrix} \mathbf{y}, \quad \mathbf{y}(0) = \begin{bmatrix} 6 \\ 5 \\ -7 \end{bmatrix}$$

$$19. \quad \mathbf{y}' = \begin{bmatrix} -2 & 2 & 1 \\ -2 & 2 & 1 \\ -3 & 3 & 2 \end{bmatrix} \mathbf{y}, \quad \mathbf{y}(0) = \begin{bmatrix} -6 \\ -2 \\ 0 \end{bmatrix}$$

$$20. \quad \mathbf{y}' = \begin{bmatrix} -7 & -4 & 4 \\ -1 & 0 & 1 \\ -9 & -5 & 6 \end{bmatrix} \mathbf{y}, \quad \mathbf{y}(0) = \begin{bmatrix} -6 \\ 9 \\ -1 \end{bmatrix}$$

$$21. \quad \mathbf{y}' = \begin{bmatrix} -1 & -4 & -1 \\ 3 & 6 & 1 \\ -3 & -2 & 3 \end{bmatrix} \mathbf{y}, \quad \mathbf{y}(0) = \begin{bmatrix} -2 \\ 1 \\ 3 \end{bmatrix}$$

$$22. \quad \mathbf{y}' = \begin{bmatrix} 4 & -8 & -4 \\ -3 & -1 & -3 \\ 1 & -1 & 9 \end{bmatrix} \mathbf{y}, \quad \mathbf{y}(0) = \begin{bmatrix} -4 \\ 1 \\ -3 \end{bmatrix}$$

$$23. \quad \mathbf{y}' = \begin{bmatrix} -5 & -1 & 11 \\ -7 & 1 & 13 \\ -4 & 0 & 8 \end{bmatrix} \mathbf{y}, \quad \mathbf{y}(0) = \begin{bmatrix} 0 \\ 2 \\ 2 \end{bmatrix}$$

The coefficient matrices in Exercises 24–32 have eigenvalues of multiplicity 3. Find the general solution.

$$24. \quad \mathbf{y}' = \begin{bmatrix} 5 & -1 & 1 \\ -1 & 9 & -3 \\ -2 & 2 & 4 \end{bmatrix} \mathbf{y} \qquad 25. \quad \mathbf{y}' = \begin{bmatrix} 1 & 10 & -12 \\ 2 & 2 & 3 \\ 2 & -1 & 6 \end{bmatrix} \mathbf{y}$$

$$26. \quad \mathbf{y}' = \begin{bmatrix} -6 & -4 & -4 \\ 2 & -1 & 1 \\ 2 & 3 & 1 \end{bmatrix} \mathbf{y} \qquad 27. \quad \mathbf{y}' = \begin{bmatrix} 0 & 2 & -2 \\ -1 & 5 & -3 \\ 1 & 1 & 1 \end{bmatrix} \mathbf{y}$$

$$28. \quad \mathbf{y}' = \begin{bmatrix} -2 & -12 & 10 \\ 2 & -24 & 11 \\ 2 & -24 & 8 \end{bmatrix} \mathbf{y} \qquad 29. \quad \mathbf{y}' = \begin{bmatrix} -1 & -12 & 8 \\ 1 & -9 & 4 \\ 1 & -6 & 1 \end{bmatrix} \mathbf{y}$$

$$30. \quad \mathbf{y}' = \begin{bmatrix} -4 & 0 & -1 \\ -1 & -3 & -1 \\ 1 & 0 & -2 \end{bmatrix} \mathbf{y} \qquad 31. \quad \mathbf{y}' = \begin{bmatrix} -3 & -3 & 4 \\ 4 & 5 & -8 \\ 2 & 3 & -5 \end{bmatrix} \mathbf{y}$$

$$32. \quad \mathbf{y}' = \begin{bmatrix} -3 & -1 & 0 \\ 1 & -1 & 0 \\ -1 & -1 & -2 \end{bmatrix} \mathbf{y}$$

33. Under the assumptions of Theorem 10.5.1, suppose  $\mathbf{u}$  and  $\hat{\mathbf{u}}$  are vectors such that

$$(A - \lambda_1 I)\mathbf{u} = \mathbf{x} \quad \text{and} \quad (A - \lambda_1 I)\hat{\mathbf{u}} = \mathbf{x},$$

and let

$$\mathbf{y}_2 = \mathbf{u}e^{\lambda_1 t} + \mathbf{x}te^{\lambda_1 t} \quad \text{and} \quad \hat{\mathbf{y}}_2 = \hat{\mathbf{u}}e^{\lambda_1 t} + \mathbf{x}te^{\lambda_1 t}.$$

Show that  $\mathbf{y}_2 - \hat{\mathbf{y}}_2$  is a scalar multiple of  $\mathbf{y}_1 = \mathbf{x}e^{\lambda_1 t}$ .

34. Under the assumptions of Theorem 10.5.2, let

$$\begin{aligned} \mathbf{y}_1 &= \mathbf{x}e^{\lambda_1 t}, \\ \mathbf{y}_2 &= \mathbf{u}e^{\lambda_1 t} + \mathbf{x}te^{\lambda_1 t}, \quad \text{and} \\ \mathbf{y}_3 &= \mathbf{v}e^{\lambda_1 t} + \mathbf{u}te^{\lambda_1 t} + \mathbf{x}\frac{t^2 e^{\lambda_1 t}}{2}. \end{aligned}$$

Complete the proof of Theorem 10.5.2 by showing that  $\mathbf{y}_3$  is a solution of  $\mathbf{y}' = A\mathbf{y}$  and that  $\{\mathbf{y}_1, \mathbf{y}_2, \mathbf{y}_3\}$  is linearly independent.

35. Suppose the matrix

$$A = \begin{bmatrix} a_{11} & a_{12} \\ a_{21} & a_{22} \end{bmatrix}$$

has a repeated eigenvalue  $\lambda_1$  and the associated eigenspace is one-dimensional. Let  $\mathbf{x}$  be a  $\lambda_1$ -eigenvector of  $A$ . Show that if  $(A - \lambda_1 I)\mathbf{u}_1 = \mathbf{x}$  and  $(A - \lambda_1 I)\mathbf{u}_2 = \mathbf{x}$ , then  $\mathbf{u}_2 - \mathbf{u}_1$  is parallel to  $\mathbf{x}$ . Conclude from this that all vectors  $\mathbf{u}$  such that  $(A - \lambda_1 I)\mathbf{u} = \mathbf{x}$  define the same positive and negative half-planes with respect to the line  $L$  through the origin parallel to  $\mathbf{x}$ .

In Exercises 36–45 plot trajectories of the given system.

36. C/G  $\mathbf{y}' = \begin{bmatrix} -3 & -1 \\ 4 & 1 \end{bmatrix} \mathbf{y}$

37. C/G  $\mathbf{y}' = \begin{bmatrix} 2 & -1 \\ 1 & 0 \end{bmatrix} \mathbf{y}$

38. C/G  $\mathbf{y}' = \begin{bmatrix} -1 & -3 \\ 3 & 5 \end{bmatrix} \mathbf{y}$

39. C/G  $\mathbf{y}' = \begin{bmatrix} -5 & 3 \\ -3 & 1 \end{bmatrix} \mathbf{y}$

40. C/G  $\mathbf{y}' = \begin{bmatrix} -2 & -3 \\ 3 & 4 \end{bmatrix} \mathbf{y}$

41. C/G  $\mathbf{y}' = \begin{bmatrix} -4 & -3 \\ 3 & 2 \end{bmatrix} \mathbf{y}$

42. C/G  $\mathbf{y}' = \begin{bmatrix} 0 & -1 \\ 1 & -2 \end{bmatrix} \mathbf{y}$

43. C/G  $\mathbf{y}' = \begin{bmatrix} 0 & 1 \\ -1 & 2 \end{bmatrix} \mathbf{y}$

44. C/G  $\mathbf{y}' = \begin{bmatrix} -2 & 1 \\ -1 & 0 \end{bmatrix} \mathbf{y}$

45. C/G  $\mathbf{y}' = \begin{bmatrix} 0 & -4 \\ 1 & -4 \end{bmatrix} \mathbf{y}$

## 10.6 CONSTANT COEFFICIENT HOMOGENEOUS SYSTEMS III

We now consider the system  $\mathbf{y}' = A\mathbf{y}$ , where  $A$  has a complex eigenvalue  $\lambda = \alpha + i\beta$  with  $\beta \neq 0$ . We continue to assume that  $A$  has real entries, so the characteristic polynomial of  $A$  has real coefficients. This implies that  $\bar{\lambda} = \alpha - i\beta$  is also an eigenvalue of  $A$ .

An eigenvector  $\mathbf{x}$  of  $A$  associated with  $\lambda = \alpha + i\beta$  will have complex entries, so we'll write

$$\mathbf{x} = \mathbf{u} + i\mathbf{v}$$

where  $\mathbf{u}$  and  $\mathbf{v}$  have real entries; that is,  $\mathbf{u}$  and  $\mathbf{v}$  are the real and imaginary parts of  $\mathbf{x}$ . Since  $A\mathbf{x} = \lambda\mathbf{x}$ ,

$$A(\mathbf{u} + i\mathbf{v}) = (\alpha + i\beta)(\mathbf{u} + i\mathbf{v}). \quad (10.6.1)$$

Taking complex conjugates here and recalling that  $A$  has real entries yields

$$A(\mathbf{u} - i\mathbf{v}) = (\alpha - i\beta)(\mathbf{u} - i\mathbf{v}),$$

which shows that  $\bar{\mathbf{x}} = \mathbf{u} - i\mathbf{v}$  is an eigenvector associated with  $\bar{\lambda} = \alpha - i\beta$ . The complex conjugate eigenvalues  $\lambda$  and  $\bar{\lambda}$  can be separately associated with linearly independent solutions  $\mathbf{y}' = A\mathbf{y}$ ; however, we won't pursue this approach, since solutions obtained in this way turn out to be complex-valued. Instead, we'll obtain solutions of  $\mathbf{y}' = A\mathbf{y}$  in the form

$$\mathbf{y} = f_1\mathbf{u} + f_2\mathbf{v} \quad (10.6.2)$$

where  $f_1$  and  $f_2$  are real-valued scalar functions. The next theorem shows how to do this.

**Theorem 10.6.1** Let  $A$  be an  $n \times n$  matrix with real entries. Let  $\lambda = \alpha + i\beta$  ( $\beta \neq 0$ ) be a complex eigenvalue of  $A$  and let  $\mathbf{x} = \mathbf{u} + i\mathbf{v}$  be an associated eigenvector, where  $\mathbf{u}$  and  $\mathbf{v}$  have real components. Then  $\mathbf{u}$  and  $\mathbf{v}$  are both nonzero and

$$\mathbf{y}_1 = e^{\alpha t}(\mathbf{u} \cos \beta t - \mathbf{v} \sin \beta t) \quad \text{and} \quad \mathbf{y}_2 = e^{\alpha t}(\mathbf{u} \sin \beta t + \mathbf{v} \cos \beta t),$$

which are the real and imaginary parts of

$$e^{\alpha t}(\cos \beta t + i \sin \beta t)(\mathbf{u} + i\mathbf{v}), \quad (10.6.3)$$

are linearly independent solutions of  $\mathbf{y}' = A\mathbf{y}$ .

**Proof** A function of the form (10.6.2) is a solution of  $\mathbf{y}' = A\mathbf{y}$  if and only if

$$f_1' \mathbf{u} + f_2' \mathbf{v} = f_1 A\mathbf{u} + f_2 A\mathbf{v}. \quad (10.6.4)$$

Carrying out the multiplication indicated on the right side of (10.6.1) and collecting the real and imaginary parts of the result yields

$$A(\mathbf{u} + i\mathbf{v}) = (\alpha\mathbf{u} - \beta\mathbf{v}) + i(\alpha\mathbf{v} + \beta\mathbf{u}).$$

Equating real and imaginary parts on the two sides of this equation yields

$$\begin{aligned} A\mathbf{u} &= \alpha\mathbf{u} - \beta\mathbf{v} \\ A\mathbf{v} &= \alpha\mathbf{v} + \beta\mathbf{u}. \end{aligned}$$

We leave it to you (Exercise 25) to show from this that  $\mathbf{u}$  and  $\mathbf{v}$  are both nonzero. Substituting from these equations into (10.6.4) yields

$$\begin{aligned} f_1' \mathbf{u} + f_2' \mathbf{v} &= f_1(\alpha\mathbf{u} - \beta\mathbf{v}) + f_2(\alpha\mathbf{v} + \beta\mathbf{u}) \\ &= (\alpha f_1 + \beta f_2)\mathbf{u} + (-\beta f_1 + \alpha f_2)\mathbf{v}. \end{aligned}$$

This is true if

$$\begin{aligned} f_1' &= \alpha f_1 + \beta f_2 & \text{or, equivalently,} & & f_1' - \alpha f_1 &= \beta f_2 \\ f_2' &= -\beta f_1 + \alpha f_2, & & & f_2' - \alpha f_2 &= -\beta f_1. \end{aligned}$$

If we let  $f_1 = g_1 e^{\alpha t}$  and  $f_2 = g_2 e^{\alpha t}$ , where  $g_1$  and  $g_2$  are to be determined, then the last two equations become

$$\begin{aligned} g_1' &= \beta g_2 \\ g_2' &= -\beta g_1, \end{aligned}$$

which implies that

$$g_1'' = \beta g_2' = -\beta^2 g_1,$$

so

$$g_1'' + \beta^2 g_1 = 0.$$

The general solution of this equation is

$$g_1 = c_1 \cos \beta t + c_2 \sin \beta t.$$

Moreover, since  $g_2 = g_1'/\beta$ ,

$$g_2 = -c_1 \sin \beta t + c_2 \cos \beta t.$$

Multiplying  $g_1$  and  $g_2$  by  $e^{\alpha t}$  shows that

$$\begin{aligned} f_1 &= e^{\alpha t}(c_1 \cos \beta t + c_2 \sin \beta t), \\ f_2 &= e^{\alpha t}(-c_1 \sin \beta t + c_2 \cos \beta t). \end{aligned}$$

Substituting these into (10.6.2) shows that

$$\begin{aligned} \mathbf{y} &= e^{\alpha t}[(c_1 \cos \beta t + c_2 \sin \beta t)\mathbf{u} + (-c_1 \sin \beta t + c_2 \cos \beta t)\mathbf{v}] \\ &= c_1 e^{\alpha t}(\mathbf{u} \cos \beta t - \mathbf{v} \sin \beta t) + c_2 e^{\alpha t}(\mathbf{u} \sin \beta t + \mathbf{v} \cos \beta t) \end{aligned} \quad (10.6.5)$$

is a solution of  $\mathbf{y}' = A\mathbf{y}$  for any choice of the constants  $c_1$  and  $c_2$ . In particular, by first taking  $c_1 = 1$  and  $c_2 = 0$  and then taking  $c_1 = 0$  and  $c_2 = 1$ , we see that  $\mathbf{y}_1$  and  $\mathbf{y}_2$  are solutions of  $\mathbf{y}' = A\mathbf{y}$ . We leave it to you to verify that they are, respectively, the real and imaginary parts of (10.6.3) (Exercise 26), and that they are linearly independent (Exercise 27).

**Example 10.6.1** Find the general solution of

$$\mathbf{y}' = \begin{bmatrix} 4 & -5 \\ 5 & -2 \end{bmatrix} \mathbf{y}. \quad (10.6.6)$$

**Solution** The characteristic polynomial of the coefficient matrix  $A$  in (10.6.6) is

$$\begin{vmatrix} 4 - \lambda & -5 \\ 5 & -2 - \lambda \end{vmatrix} = (\lambda - 1)^2 + 16.$$

Hence,  $\lambda = 1 + 4i$  is an eigenvalue of  $A$ . The associated eigenvectors satisfy  $(A - (1 + 4i)I)\mathbf{x} = \mathbf{0}$ . The augmented matrix of this system is

$$\begin{bmatrix} 3 - 4i & -5 & \vdots & 0 \\ 5 & -3 - 4i & \vdots & 0 \end{bmatrix},$$

which is row equivalent to

$$\begin{bmatrix} 1 & -\frac{3+4i}{5} & \vdots & 0 \\ 0 & 0 & \vdots & 0 \end{bmatrix}.$$

Therefore  $x_1 = (3 + 4i)x_2/5$ . Taking  $x_2 = 5$  yields  $x_1 = 3 + 4i$ , so

$$\mathbf{x} = \begin{bmatrix} 3 + 4i \\ 5 \end{bmatrix}$$

is an eigenvector. The real and imaginary parts of

$$e^t(\cos 4t + i \sin 4t) \begin{bmatrix} 3 + 4i \\ 5 \end{bmatrix}$$

are

$$\mathbf{y}_1 = e^t \begin{bmatrix} 3 \cos 4t - 4 \sin 4t \\ 5 \cos 4t \end{bmatrix} \quad \text{and} \quad \mathbf{y}_2 = e^t \begin{bmatrix} 3 \sin 4t + 4 \cos 4t \\ 5 \sin 4t \end{bmatrix},$$

which are linearly independent solutions of (10.6.6). The general solution of (10.6.6) is

$$\mathbf{y} = c_1 e^t \begin{bmatrix} 3 \cos 4t - 4 \sin 4t \\ 5 \cos 4t \end{bmatrix} + c_2 e^t \begin{bmatrix} 3 \sin 4t + 4 \cos 4t \\ 5 \sin 4t \end{bmatrix}.$$

**Example 10.6.2** Find the general solution of

$$\mathbf{y}' = \begin{bmatrix} -14 & 39 \\ -6 & 16 \end{bmatrix} \mathbf{y}. \quad (10.6.7)$$

**Solution** The characteristic polynomial of the coefficient matrix  $A$  in (10.6.7) is

$$\begin{vmatrix} -14 - \lambda & 39 \\ -6 & 16 - \lambda \end{vmatrix} = (\lambda - 1)^2 + 9.$$

Hence,  $\lambda = 1 + 3i$  is an eigenvalue of  $A$ . The associated eigenvectors satisfy  $(A - (1 + 3i)I)\mathbf{x} = \mathbf{0}$ . The augmented augmented matrix of this system is

$$\left[ \begin{array}{ccc|c} -15 - 3i & 39 & \vdots & 0 \\ -6 & 15 - 3i & \vdots & 0 \end{array} \right],$$

which is row equivalent to

$$\left[ \begin{array}{ccc|c} 1 & \frac{-5+i}{2} & \vdots & 0 \\ 0 & 0 & \vdots & 0 \end{array} \right].$$

Therefore  $x_1 = (5 - i)/2$ . Taking  $x_2 = 2$  yields  $x_1 = 5 - i$ , so

$$\mathbf{x} = \begin{bmatrix} 5 - i \\ 2 \end{bmatrix}$$

is an eigenvector. The real and imaginary parts of

$$e^t(\cos 3t + i \sin 3t) \begin{bmatrix} 5 - i \\ 2 \end{bmatrix}$$

are

$$\mathbf{y}_1 = e^t \begin{bmatrix} \sin 3t + 5 \cos 3t \\ 2 \cos 3t \end{bmatrix} \quad \text{and} \quad \mathbf{y}_2 = e^t \begin{bmatrix} -\cos 3t + 5 \sin 3t \\ 2 \sin 3t \end{bmatrix},$$

which are linearly independent solutions of (10.6.7). The general solution of (10.6.7) is

$$\mathbf{y} = c_1 e^t \begin{bmatrix} \sin 3t + 5 \cos 3t \\ 2 \cos 3t \end{bmatrix} + c_2 e^t \begin{bmatrix} -\cos 3t + 5 \sin 3t \\ 2 \sin 3t \end{bmatrix}.$$

**Example 10.6.3** Find the general solution of

$$\mathbf{y}' = \begin{bmatrix} -5 & 5 & 4 \\ -8 & 7 & 6 \\ 1 & 0 & 0 \end{bmatrix} \mathbf{y}. \quad (10.6.8)$$

**Solution** The characteristic polynomial of the coefficient matrix  $A$  in (10.6.8) is

$$\begin{vmatrix} -5 - \lambda & 5 & 4 \\ -8 & 7 - \lambda & 6 \\ 1 & 0 & -\lambda \end{vmatrix} = -(\lambda - 2)(\lambda^2 + 1).$$

Hence, the eigenvalues of  $A$  are  $\lambda_1 = 2$ ,  $\lambda_2 = i$ , and  $\lambda_3 = -i$ . The augmented matrix of  $(A - 2I)\mathbf{x} = \mathbf{0}$  is

$$\begin{bmatrix} -7 & 5 & 4 & \vdots & 0 \\ -8 & 5 & 6 & \vdots & 0 \\ 1 & 0 & -2 & \vdots & 0 \end{bmatrix},$$

which is row equivalent to

$$\begin{bmatrix} 1 & 0 & -2 & \vdots & 0 \\ 0 & 1 & -2 & \vdots & 0 \\ 0 & 0 & 0 & \vdots & 0 \end{bmatrix}.$$

Therefore  $x_1 = x_2 = 2x_3$ . Taking  $x_3 = 1$  yields

$$\mathbf{x}_1 = \begin{bmatrix} 2 \\ 2 \\ 1 \end{bmatrix},$$

so

$$\mathbf{y}_1 = \begin{bmatrix} 2 \\ 2 \\ 1 \end{bmatrix} e^{2t}$$

is a solution of (10.6.8).

The augmented matrix of  $(A - iI)\mathbf{x} = \mathbf{0}$  is

$$\begin{bmatrix} -5 - i & 5 & 4 & \vdots & 0 \\ -8 & 7 - i & 6 & \vdots & 0 \\ 1 & 0 & -i & \vdots & 0 \end{bmatrix},$$

which is row equivalent to

$$\begin{bmatrix} 1 & 0 & -i & \vdots & 0 \\ 0 & 1 & 1 - i & \vdots & 0 \\ 0 & 0 & 0 & \vdots & 0 \end{bmatrix}.$$

Therefore  $x_1 = ix_3$  and  $x_2 = -(1 - i)x_3$ . Taking  $x_3 = 1$  yields the eigenvector

$$\mathbf{x}_2 = \begin{bmatrix} i \\ -1 + i \\ 1 \end{bmatrix}.$$

The real and imaginary parts of

$$(\cos t + i \sin t) \begin{bmatrix} i \\ -1 + i \\ 1 \end{bmatrix}$$

are

$$\mathbf{y}_2 = \begin{bmatrix} -\sin t \\ -\cos t - \sin t \\ \cos t \end{bmatrix} \quad \text{and} \quad \mathbf{y}_3 = \begin{bmatrix} \cos t \\ \cos t - \sin t \\ \sin t \end{bmatrix},$$

which are solutions of (10.6.8). Since the Wronskian of  $\{y_1, y_2, y_3\}$  at  $t = 0$  is

$$\begin{vmatrix} 2 & 0 & 1 \\ 2 & -1 & 1 \\ 1 & 1 & 0 \end{vmatrix} = 1,$$

$\{y_1, y_2, y_3\}$  is a fundamental set of solutions of (10.6.8). The general solution of (10.6.8) is

$$\mathbf{y} = c_1 \begin{bmatrix} 2 \\ 2 \\ 1 \end{bmatrix} e^{2t} + c_2 \begin{bmatrix} -\sin t \\ -\cos t - \sin t \\ \cos t \end{bmatrix} + c_3 \begin{bmatrix} \cos t \\ \cos t - \sin t \\ \sin t \end{bmatrix}.$$

**Example 10.6.4** Find the general solution of

$$\mathbf{y}' = \begin{bmatrix} 1 & -1 & -2 \\ 1 & 3 & 2 \\ 1 & -1 & 2 \end{bmatrix} \mathbf{y}. \quad (10.6.9)$$

**Solution** The characteristic polynomial of the coefficient matrix  $A$  in (10.6.9) is

$$\begin{vmatrix} 1 - \lambda & -1 & -2 \\ 1 & 3 - \lambda & 2 \\ 1 & -1 & 2 - \lambda \end{vmatrix} = -(\lambda - 2)((\lambda - 2)^2 + 4).$$

Hence, the eigenvalues of  $A$  are  $\lambda_1 = 2$ ,  $\lambda_2 = 2 + 2i$ , and  $\lambda_3 = 2 - 2i$ . The augmented matrix of  $(A - 2I)\mathbf{x} = \mathbf{0}$  is

$$\left[ \begin{array}{cccc|c} -1 & -1 & -2 & \vdots & 0 \\ 1 & 1 & 2 & \vdots & 0 \\ 1 & -1 & 0 & \vdots & 0 \end{array} \right],$$

which is row equivalent to

$$\left[ \begin{array}{cccc|c} 1 & 0 & 1 & \vdots & 0 \\ 0 & 1 & 1 & \vdots & 0 \\ 0 & 0 & 0 & \vdots & 0 \end{array} \right].$$

Therefore  $x_1 = x_2 = -x_3$ . Taking  $x_3 = 1$  yields

$$\mathbf{x}_1 = \begin{bmatrix} -1 \\ -1 \\ 1 \end{bmatrix},$$

so

$$\mathbf{y}_1 = \begin{bmatrix} -1 \\ -1 \\ 1 \end{bmatrix} e^{2t}$$

is a solution of (10.6.9).

The augmented matrix of  $(A - (2 + 2i)I)\mathbf{x} = \mathbf{0}$  is

$$\left[ \begin{array}{cccc|c} -1 - 2i & -1 & -2 & \vdots & 0 \\ 1 & 1 - 2i & 2 & \vdots & 0 \\ 1 & -1 & -2i & \vdots & 0 \end{array} \right],$$



which is row equivalent to

$$\begin{bmatrix} 1 & 0 & -i & \vdots & 0 \\ 0 & 1 & i & \vdots & 0 \\ 0 & 0 & 0 & \vdots & 0 \end{bmatrix}.$$

Therefore  $x_1 = ix_3$  and  $x_2 = -ix_3$ . Taking  $x_3 = 1$  yields the eigenvector

$$\mathbf{x}_2 = \begin{bmatrix} i \\ -i \\ 1 \end{bmatrix}$$

The real and imaginary parts of

$$e^{2t}(\cos 2t + i \sin 2t) \begin{bmatrix} i \\ -i \\ 1 \end{bmatrix}$$

are

$$\mathbf{y}_1 = e^{2t} \begin{bmatrix} -\sin 2t \\ \sin 2t \\ \cos 2t \end{bmatrix} \quad \text{and} \quad \mathbf{y}_2 = e^{2t} \begin{bmatrix} \cos 2t \\ -\cos 2t \\ \sin 2t \end{bmatrix},$$

which are solutions of (10.6.9). Since the Wronskian of  $\{\mathbf{y}_1, \mathbf{y}_2, \mathbf{y}_3\}$  at  $t = 0$  is

$$\begin{vmatrix} -1 & 0 & 1 \\ -1 & 0 & -1 \\ 1 & 1 & 0 \end{vmatrix} = -2,$$

$\{\mathbf{y}_1, \mathbf{y}_2, \mathbf{y}_3\}$  is a fundamental set of solutions of (10.6.9). The general solution of (10.6.9) is

$$\mathbf{y} = c_1 \begin{bmatrix} -1 \\ -1 \\ 1 \end{bmatrix} e^{2t} + c_2 e^{2t} \begin{bmatrix} -\sin 2t \\ \sin 2t \\ \cos 2t \end{bmatrix} + c_3 e^{2t} \begin{bmatrix} \cos 2t \\ -\cos 2t \\ \sin 2t \end{bmatrix}.$$

### Geometric Properties of Solutions when $n = 2$

We'll now consider the geometric properties of solutions of a  $2 \times 2$  constant coefficient system

$$\begin{bmatrix} y_1' \\ y_2' \end{bmatrix} = \begin{bmatrix} a_{11} & a_{12} \\ a_{21} & a_{22} \end{bmatrix} \begin{bmatrix} y_1 \\ y_2 \end{bmatrix} \quad (10.6.10)$$

under the assumptions of this section; that is, when the matrix

$$A = \begin{bmatrix} a_{11} & a_{12} \\ a_{21} & a_{22} \end{bmatrix}$$

has a complex eigenvalue  $\lambda = \alpha + i\beta$  ( $\beta \neq 0$ ) and  $\mathbf{x} = \mathbf{u} + i\mathbf{v}$  is an associated eigenvector, where  $\mathbf{u}$  and  $\mathbf{v}$  have real components. To describe the trajectories accurately it's necessary to introduce a new rectangular coordinate system in the  $y_1$ - $y_2$  plane. This raises a point that hasn't come up before: It is always possible to choose  $\mathbf{x}$  so that  $(\mathbf{u}, \mathbf{v}) = 0$ . A special effort is required to do this, since not every eigenvector has this property. However, if we know an eigenvector that doesn't, we can multiply it by a suitable complex constant to obtain one that does. To see this, note that if  $\mathbf{x}$  is a  $\lambda$ -eigenvector of  $A$  and  $k$  is an arbitrary real number, then

$$\mathbf{x}_1 = (1 + ik)\mathbf{x} = (1 + ik)(\mathbf{u} + i\mathbf{v}) = (\mathbf{u} - k\mathbf{v}) + i(\mathbf{v} + k\mathbf{u})$$

is also a  $\lambda$ -eigenvector of  $A$ , since

$$A\mathbf{x}_1 = A((1 + ik)\mathbf{x}) = (1 + ik)A\mathbf{x} = (1 + ik)\lambda\mathbf{x} = \lambda((1 + ik)\mathbf{x}) = \lambda\mathbf{x}_1.$$

The real and imaginary parts of  $\mathbf{x}_1$  are

$$\mathbf{u}_1 = \mathbf{u} - k\mathbf{v} \quad \text{and} \quad \mathbf{v}_1 = \mathbf{v} + k\mathbf{u}, \quad (10.6.11)$$

so

$$(\mathbf{u}_1, \mathbf{v}_1) = (\mathbf{u} - k\mathbf{v}, \mathbf{v} + k\mathbf{u}) = -[(\mathbf{u}, \mathbf{v})k^2 + (\|\mathbf{v}\|^2 - \|\mathbf{u}\|^2)k - (\mathbf{u}, \mathbf{v})].$$

Therefore  $(\mathbf{u}_1, \mathbf{v}_1) = 0$  if

$$(\mathbf{u}, \mathbf{v})k^2 + (\|\mathbf{v}\|^2 - \|\mathbf{u}\|^2)k - (\mathbf{u}, \mathbf{v}) = 0. \quad (10.6.12)$$

If  $(\mathbf{u}, \mathbf{v}) \neq 0$  we can use the quadratic formula to find two real values of  $k$  such that  $(\mathbf{u}_1, \mathbf{v}_1) = 0$  (Exercise 28).

**Example 10.6.5** In Example 10.6.1 we found the eigenvector

$$\mathbf{x} = \begin{bmatrix} 3 + 4i \\ 5 \end{bmatrix} = \begin{bmatrix} 3 \\ 5 \end{bmatrix} + i \begin{bmatrix} 4 \\ 0 \end{bmatrix}$$

for the matrix of the system (10.6.6). Here  $\mathbf{u} = \begin{bmatrix} 3 \\ 5 \end{bmatrix}$  and  $\mathbf{v} = \begin{bmatrix} 4 \\ 0 \end{bmatrix}$  are not orthogonal, since  $(\mathbf{u}, \mathbf{v}) = 12$ . Since  $\|\mathbf{v}\|^2 - \|\mathbf{u}\|^2 = -18$ , (10.6.12) is equivalent to

$$2k^2 - 3k - 2 = 0.$$

The zeros of this equation are  $k_1 = 2$  and  $k_2 = -1/2$ . Letting  $k = 2$  in (10.6.11) yields

$$\mathbf{u}_1 = \mathbf{u} - 2\mathbf{v} = \begin{bmatrix} -5 \\ 5 \end{bmatrix} \quad \text{and} \quad \mathbf{v}_1 = \mathbf{v} + 2\mathbf{u} = \begin{bmatrix} 10 \\ 10 \end{bmatrix},$$

and  $(\mathbf{u}_1, \mathbf{v}_1) = 0$ . Letting  $k = -1/2$  in (10.6.11) yields

$$\mathbf{u}_1 = \mathbf{u} + \frac{\mathbf{v}}{2} = \begin{bmatrix} 5 \\ 5 \end{bmatrix} \quad \text{and} \quad \mathbf{v}_1 = \mathbf{v} - \frac{\mathbf{u}}{2} = \frac{1}{2} \begin{bmatrix} -5 \\ 5 \end{bmatrix},$$

and again  $(\mathbf{u}_1, \mathbf{v}_1) = 0$ . ■

(The numbers don't always work out as nicely as in this example. You'll need a calculator or computer to do Exercises 29-40.)

Henceforth, we'll assume that  $(\mathbf{u}, \mathbf{v}) = 0$ . Let  $\mathbf{U}$  and  $\mathbf{V}$  be unit vectors in the directions of  $\mathbf{u}$  and  $\mathbf{v}$ , respectively; that is,  $\mathbf{U} = \mathbf{u}/\|\mathbf{u}\|$  and  $\mathbf{V} = \mathbf{v}/\|\mathbf{v}\|$ . The new rectangular coordinate system will have the same origin as the  $y_1$ - $y_2$  system. The coordinates of a point in this system will be denoted by  $(z_1, z_2)$ , where  $z_1$  and  $z_2$  are the displacements in the directions of  $\mathbf{U}$  and  $\mathbf{V}$ , respectively.

From (10.6.5), the solutions of (10.6.10) are given by

$$\mathbf{y} = e^{\alpha t} [(c_1 \cos \beta t + c_2 \sin \beta t)\mathbf{u} + (-c_1 \sin \beta t + c_2 \cos \beta t)\mathbf{v}]. \quad (10.6.13)$$

For convenience, let's call the curve traversed by  $e^{-\alpha t}\mathbf{y}(t)$  a *shadow trajectory* of (10.6.10). Multiplying (10.6.13) by  $e^{-\alpha t}$  yields

$$e^{-\alpha t}\mathbf{y}(t) = z_1(t)\mathbf{U} + z_2(t)\mathbf{V},$$

where

$$\begin{aligned} z_1(t) &= \|\mathbf{u}\|(c_1 \cos \beta t + c_2 \sin \beta t) \\ z_2(t) &= \|\mathbf{v}\|(-c_1 \sin \beta t + c_2 \cos \beta t). \end{aligned}$$

Therefore

$$\frac{(z_1(t))^2}{\|\mathbf{u}\|^2} + \frac{(z_2(t))^2}{\|\mathbf{v}\|^2} = c_1^2 + c_2^2$$

(verify!), which means that the shadow trajectories of (10.6.10) are ellipses centered at the origin, with axes of symmetry parallel to  $\mathbf{U}$  and  $\mathbf{V}$ . Since

$$z_1' = \frac{\beta\|\mathbf{u}\|}{\|\mathbf{v}\|}z_2 \quad \text{and} \quad z_2' = -\frac{\beta\|\mathbf{v}\|}{\|\mathbf{u}\|}z_1,$$

the vector from the origin to a point on the shadow ellipse rotates in the same direction that  $\mathbf{V}$  would have to be rotated by  $\pi/2$  radians to bring it into coincidence with  $\mathbf{U}$  (Figures 10.6.1 and 10.6.2).

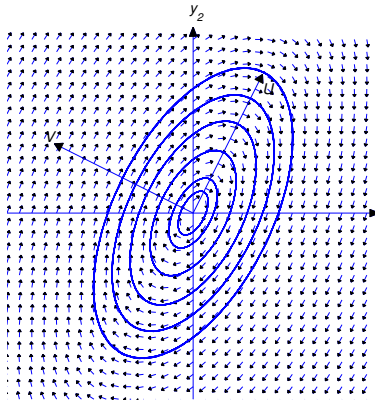

Figure 10.6.1 Shadow trajectories traversed clockwise

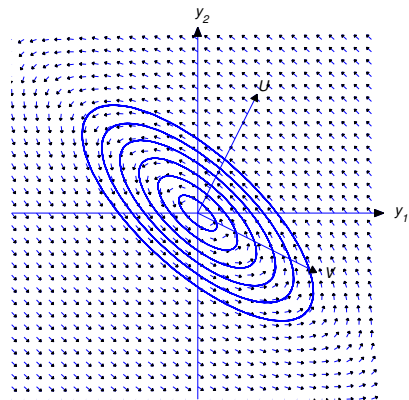

Figure 10.6.2 Shadow trajectories traversed counterclockwise

If  $\alpha = 0$ , then any trajectory of (10.6.10) is a shadow trajectory of (10.6.10); therefore, if  $\lambda$  is purely imaginary, then the trajectories of (10.6.10) are ellipses traversed periodically as indicated in Figures 10.6.1 and 10.6.2.

If  $\alpha > 0$ , then

$$\lim_{t \rightarrow \infty} \|\mathbf{y}(t)\| = \infty \quad \text{and} \quad \lim_{t \rightarrow -\infty} \mathbf{y}(t) = 0,$$

so the trajectory spirals away from the origin as  $t$  varies from  $-\infty$  to  $\infty$ . The direction of the spiral depends upon the relative orientation of  $\mathbf{U}$  and  $\mathbf{V}$ , as shown in Figures 10.6.3 and 10.6.4.

If  $\alpha < 0$ , then

$$\lim_{t \rightarrow -\infty} \|\mathbf{y}(t)\| = \infty \quad \text{and} \quad \lim_{t \rightarrow \infty} \mathbf{y}(t) = 0,$$

so the trajectory spirals toward the origin as  $t$  varies from  $-\infty$  to  $\infty$ . Again, the direction of the spiral depends upon the relative orientation of  $\mathbf{U}$  and  $\mathbf{V}$ , as shown in Figures 10.6.5 and 10.6.6.

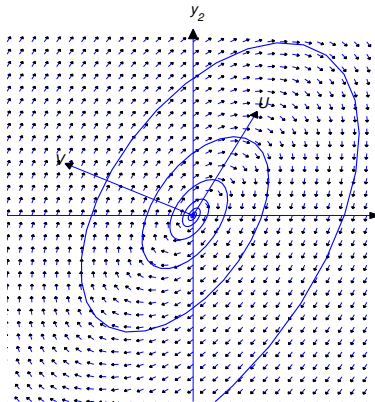

Figure 10.6.3  $\alpha > 0$ ; shadow trajectory spiraling outward

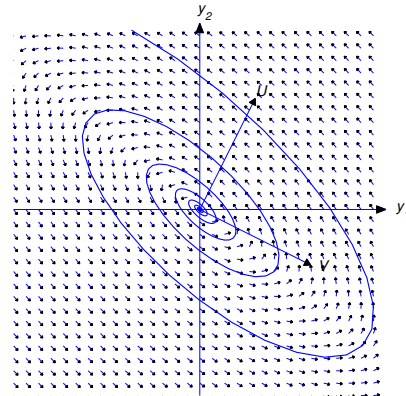

Figure 10.6.4  $\alpha > 0$ ; shadow trajectory spiraling outward

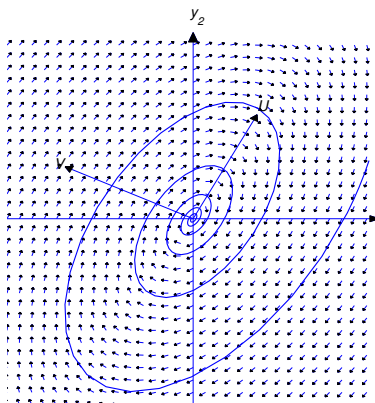

Figure 10.6.5  $\alpha < 0$ ; shadow trajectory spiraling inward

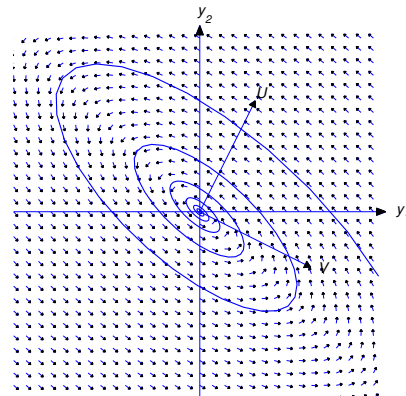

Figure 10.6.6  $\alpha < 0$ ; shadow trajectory spiraling inward

### 10.6 Exercises

In Exercises 1–16 find the general solution.

1.  $y' = \begin{bmatrix} -1 & 2 \\ -5 & 5 \end{bmatrix} y$

2.  $y' = \begin{bmatrix} -11 & 4 \\ -26 & 9 \end{bmatrix} y$

3.  $y' = \begin{bmatrix} 1 & 2 \\ -4 & 5 \end{bmatrix} y$

4.  $y' = \begin{bmatrix} 5 & -6 \\ 3 & -1 \end{bmatrix} y$

$$5. \mathbf{y}' = \begin{bmatrix} 3 & -3 & 1 \\ 0 & 2 & 2 \\ 5 & 1 & 1 \end{bmatrix} \mathbf{y} \qquad 6. \mathbf{y}' = \begin{bmatrix} -3 & 3 & 1 \\ 1 & -5 & -3 \\ -3 & 7 & 3 \end{bmatrix} \mathbf{y}$$

$$7. \mathbf{y}' = \begin{bmatrix} 2 & 1 & -1 \\ 0 & 1 & 1 \\ 1 & 0 & 1 \end{bmatrix} \mathbf{y} \qquad 8. \mathbf{y}' = \begin{bmatrix} -3 & 1 & -3 \\ 4 & -1 & 2 \\ 4 & -2 & 3 \end{bmatrix} \mathbf{y}$$

$$9. \mathbf{y}' = \begin{bmatrix} 5 & -4 \\ 10 & 1 \end{bmatrix} \mathbf{y} \qquad 10. \mathbf{y}' = \frac{1}{3} \begin{bmatrix} 7 & -5 \\ 2 & 5 \end{bmatrix} \mathbf{y}$$

$$11. \mathbf{y}' = \begin{bmatrix} 3 & 2 \\ -5 & 1 \end{bmatrix} \mathbf{y} \qquad 12. \mathbf{y}' = \begin{bmatrix} 34 & 52 \\ -20 & -30 \end{bmatrix} \mathbf{y}$$

$$13. \mathbf{y}' = \begin{bmatrix} 1 & 1 & 2 \\ 1 & 0 & -1 \\ -1 & -2 & -1 \end{bmatrix} \mathbf{y} \qquad 14. \mathbf{y}' = \begin{bmatrix} 3 & -4 & -2 \\ -5 & 7 & -8 \\ -10 & 13 & -8 \end{bmatrix} \mathbf{y}$$

$$15. \mathbf{y}' = \begin{bmatrix} 6 & 0 & -3 \\ -3 & 3 & 3 \\ 1 & -2 & 6 \end{bmatrix} \mathbf{y}' \qquad 16. \mathbf{y}' = \begin{bmatrix} 1 & 2 & -2 \\ 0 & 2 & -1 \\ 1 & 0 & 0 \end{bmatrix} \mathbf{y}'$$

In Exercises 17–24 solve the initial value problem.

$$17. \mathbf{y}' = \begin{bmatrix} 4 & -6 \\ 3 & -2 \end{bmatrix} \mathbf{y}, \quad \mathbf{y}(0) = \begin{bmatrix} 5 \\ 2 \end{bmatrix}$$

$$18. \mathbf{y}' = \begin{bmatrix} 7 & 15 \\ -3 & 1 \end{bmatrix} \mathbf{y}, \quad \mathbf{y}(0) = \begin{bmatrix} 5 \\ 1 \end{bmatrix}$$

$$19. \mathbf{y}' = \begin{bmatrix} 7 & -15 \\ 3 & -5 \end{bmatrix} \mathbf{y}, \quad \mathbf{y}(0) = \begin{bmatrix} 17 \\ 7 \end{bmatrix}$$

$$20. \mathbf{y}' = \frac{1}{6} \begin{bmatrix} 4 & -2 \\ 5 & 2 \end{bmatrix} \mathbf{y}, \quad \mathbf{y}(0) = \begin{bmatrix} 1 \\ -1 \end{bmatrix}$$

$$21. \mathbf{y}' = \begin{bmatrix} 5 & 2 & -1 \\ -3 & 2 & 2 \\ 1 & 3 & 2 \end{bmatrix} \mathbf{y}, \quad \mathbf{y}(0) = \begin{bmatrix} 4 \\ 0 \\ 6 \end{bmatrix}$$

$$22. \mathbf{y}' = \begin{bmatrix} 4 & 4 & 0 \\ 8 & 10 & -20 \\ 2 & 3 & -2 \end{bmatrix} \mathbf{y}, \quad \mathbf{y}(0) = \begin{bmatrix} 8 \\ 6 \\ 5 \end{bmatrix}$$

$$23. \mathbf{y}' = \begin{bmatrix} 1 & 15 & -15 \\ -6 & 18 & -22 \\ -3 & 11 & -15 \end{bmatrix} \mathbf{y}, \quad \mathbf{y}(0) = \begin{bmatrix} 15 \\ 17 \\ 10 \end{bmatrix}$$

$$24. \mathbf{y}' = \begin{bmatrix} 4 & -4 & 4 \\ -10 & 3 & 15 \\ 2 & -3 & 1 \end{bmatrix} \mathbf{y}, \quad \mathbf{y}(0) = \begin{bmatrix} 16 \\ 14 \\ 6 \end{bmatrix}$$

25. Suppose an  $n \times n$  matrix  $A$  with real entries has a complex eigenvalue  $\lambda = \alpha + i\beta$  ( $\beta \neq 0$ ) with associated eigenvector  $\mathbf{x} = \mathbf{u} + i\mathbf{v}$ , where  $\mathbf{u}$  and  $\mathbf{v}$  have real components. Show that  $\mathbf{u}$  and  $\mathbf{v}$  are both nonzero.
26. Verify that

$$\mathbf{y}_1 = e^{\alpha t}(\mathbf{u} \cos \beta t - \mathbf{v} \sin \beta t) \quad \text{and} \quad \mathbf{y}_2 = e^{\alpha t}(\mathbf{u} \sin \beta t + \mathbf{v} \cos \beta t),$$

are the real and imaginary parts of

$$e^{\alpha t}(\cos \beta t + i \sin \beta t)(\mathbf{u} + i\mathbf{v}).$$

27. Show that if the vectors  $\mathbf{u}$  and  $\mathbf{v}$  are not both  $\mathbf{0}$  and  $\beta \neq 0$  then the vector functions

$$\mathbf{y}_1 = e^{\alpha t}(\mathbf{u} \cos \beta t - \mathbf{v} \sin \beta t) \quad \text{and} \quad \mathbf{y}_2 = e^{\alpha t}(\mathbf{u} \sin \beta t + \mathbf{v} \cos \beta t)$$

are linearly independent on every interval. HINT: *There are two cases to consider: (i)  $\{\mathbf{u}, \mathbf{v}\}$  linearly independent, and (ii)  $\{\mathbf{u}, \mathbf{v}\}$  linearly dependent. In either case, exploit the linear independence of  $\{\cos \beta t, \sin \beta t\}$  on every interval.*

28. Suppose  $\mathbf{u} = \begin{bmatrix} u_1 \\ u_2 \end{bmatrix}$  and  $\mathbf{v} = \begin{bmatrix} v_1 \\ v_2 \end{bmatrix}$  are not orthogonal; that is,  $(\mathbf{u}, \mathbf{v}) \neq 0$ .

(a) Show that the quadratic equation

$$(\mathbf{u}, \mathbf{v})k^2 + (\|\mathbf{v}\|^2 - \|\mathbf{u}\|^2)k - (\mathbf{u}, \mathbf{v}) = 0$$

has a positive root  $k_1$  and a negative root  $k_2 = -1/k_1$ .

- (b) Let  $\mathbf{u}_1^{(1)} = \mathbf{u} - k_1\mathbf{v}$ ,  $\mathbf{v}_1^{(1)} = \mathbf{v} + k_1\mathbf{u}$ ,  $\mathbf{u}_1^{(2)} = \mathbf{u} - k_2\mathbf{v}$ , and  $\mathbf{v}_1^{(2)} = \mathbf{v} + k_2\mathbf{u}$ , so that  $(\mathbf{u}_1^{(1)}, \mathbf{v}_1^{(1)}) = (\mathbf{u}_1^{(2)}, \mathbf{v}_1^{(2)}) = 0$ , from the discussion given above. Show that

$$\mathbf{u}_1^{(2)} = \frac{\mathbf{v}_1^{(1)}}{k_1} \quad \text{and} \quad \mathbf{v}_1^{(2)} = -\frac{\mathbf{u}_1^{(1)}}{k_1}.$$

- (c) Let  $\mathbf{U}_1$ ,  $\mathbf{V}_1$ ,  $\mathbf{U}_2$ , and  $\mathbf{V}_2$  be unit vectors in the directions of  $\mathbf{u}_1^{(1)}$ ,  $\mathbf{v}_1^{(1)}$ ,  $\mathbf{u}_1^{(2)}$ , and  $\mathbf{v}_1^{(2)}$ , respectively. Conclude from (a) that  $\mathbf{U}_2 = \mathbf{V}_1$  and  $\mathbf{V}_2 = -\mathbf{U}_1$ , and that therefore the counterclockwise angles from  $\mathbf{U}_1$  to  $\mathbf{V}_1$  and from  $\mathbf{U}_2$  to  $\mathbf{V}_2$  are both  $\pi/2$  or both  $-\pi/2$ .

In Exercises 29-32 find vectors  $\mathbf{U}$  and  $\mathbf{V}$  parallel to the axes of symmetry of the trajectories, and plot some typical trajectories.

29. C/G  $\mathbf{y}' = \begin{bmatrix} 3 & -5 \\ 5 & -3 \end{bmatrix} \mathbf{y}$       30. C/G  $\mathbf{y}' = \begin{bmatrix} -15 & 10 \\ -25 & 15 \end{bmatrix} \mathbf{y}$

31. C/G  $\mathbf{y}' = \begin{bmatrix} -4 & 8 \\ -4 & 4 \end{bmatrix} \mathbf{y}$       32. C/G  $\mathbf{y}' = \begin{bmatrix} -3 & -15 \\ 3 & 3 \end{bmatrix} \mathbf{y}$

In Exercises 33-40 find vectors  $\mathbf{U}$  and  $\mathbf{V}$  parallel to the axes of symmetry of the shadow trajectories, and plot a typical trajectory.

33. C/G  $\mathbf{y}' = \begin{bmatrix} -5 & 6 \\ -12 & 7 \end{bmatrix} \mathbf{y}$       34. C/G  $\mathbf{y}' = \begin{bmatrix} 5 & -12 \\ 6 & -7 \end{bmatrix} \mathbf{y}$

$$35. \quad \boxed{\text{C/G}} \quad \mathbf{y}' = \begin{bmatrix} 4 & -5 \\ 9 & -2 \end{bmatrix} \mathbf{y} \qquad 36. \quad \boxed{\text{C/G}} \quad \mathbf{y}' = \begin{bmatrix} -4 & 9 \\ -5 & 2 \end{bmatrix} \mathbf{y}$$

$$37. \quad \boxed{\text{C/G}} \quad \mathbf{y}' = \begin{bmatrix} -1 & 10 \\ -10 & -1 \end{bmatrix} \mathbf{y} \qquad 38. \quad \boxed{\text{C/G}} \quad \mathbf{y}' = \begin{bmatrix} -1 & -5 \\ 20 & -1 \end{bmatrix} \mathbf{y}$$

$$39. \quad \boxed{\text{C/G}} \quad \mathbf{y}' = \begin{bmatrix} -7 & 10 \\ -10 & 9 \end{bmatrix} \mathbf{y} \qquad 40. \quad \boxed{\text{C/G}} \quad \mathbf{y}' = \begin{bmatrix} -7 & 6 \\ -12 & 5 \end{bmatrix} \mathbf{y}$$

## 10.7 VARIATION OF PARAMETERS FOR NONHOMOGENEOUS LINEAR SYSTEMS

We now consider the nonhomogeneous linear system

$$\mathbf{y}' = A(t)\mathbf{y} + \mathbf{f}(t),$$

where  $A$  is an  $n \times n$  matrix function and  $\mathbf{f}$  is an  $n$ -vector forcing function. Associated with this system is the *complementary system*  $\mathbf{y}' = A(t)\mathbf{y}$ .

The next theorem is analogous to Theorems 5.3.2 and 9.1.5. It shows how to find the general solution of  $\mathbf{y}' = A(t)\mathbf{y} + \mathbf{f}(t)$  if we know a particular solution of  $\mathbf{y}' = A(t)\mathbf{y} + \mathbf{f}(t)$  and a fundamental set of solutions of the complementary system. We leave the proof as an exercise (Exercise 21).

**Theorem 10.7.1** *Suppose the  $n \times n$  matrix function  $A$  and the  $n$ -vector function  $\mathbf{f}$  are continuous on  $(a, b)$ . Let  $\mathbf{y}_p$  be a particular solution of  $\mathbf{y}' = A(t)\mathbf{y} + \mathbf{f}(t)$  on  $(a, b)$ , and let  $\{\mathbf{y}_1, \mathbf{y}_2, \dots, \mathbf{y}_n\}$  be a fundamental set of solutions of the complementary equation  $\mathbf{y}' = A(t)\mathbf{y}$  on  $(a, b)$ . Then  $\mathbf{y}$  is a solution of  $\mathbf{y}' = A(t)\mathbf{y} + \mathbf{f}(t)$  on  $(a, b)$  if and only if*

$$\mathbf{y} = \mathbf{y}_p + c_1\mathbf{y}_1 + c_2\mathbf{y}_2 + \cdots + c_n\mathbf{y}_n,$$

where  $c_1, c_2, \dots, c_n$  are constants.

### Finding a Particular Solution of a Nonhomogeneous System

We now discuss an extension of the method of variation of parameters to linear nonhomogeneous systems. This method will produce a particular solution of a nonhomogeneous system  $\mathbf{y}' = A(t)\mathbf{y} + \mathbf{f}(t)$  provided that we know a fundamental matrix for the complementary system. To derive the method, suppose  $Y$  is a fundamental matrix for the complementary system; that is,

$$Y = \begin{bmatrix} y_{11} & y_{12} & \cdots & y_{1n} \\ y_{21} & y_{22} & \cdots & y_{2n} \\ \vdots & \vdots & \ddots & \vdots \\ y_{n1} & y_{n2} & \cdots & y_{nn} \end{bmatrix},$$

where

$$\mathbf{y}_1 = \begin{bmatrix} y_{11} \\ y_{21} \\ \vdots \\ y_{n1} \end{bmatrix}, \quad \mathbf{y}_2 = \begin{bmatrix} y_{12} \\ y_{22} \\ \vdots \\ y_{n2} \end{bmatrix}, \quad \dots, \quad \mathbf{y}_n = \begin{bmatrix} y_{1n} \\ y_{2n} \\ \vdots \\ y_{nn} \end{bmatrix}$$

is a fundamental set of solutions of the complementary system. In Section 10.3 we saw that  $Y' = A(t)Y$ . We seek a particular solution of

$$\mathbf{y}' = A(t)\mathbf{y} + \mathbf{f}(t) \tag{10.7.1}$$

of the form

$$\mathbf{y}_p = Y\mathbf{u}, \tag{10.7.2}$$

where  $\mathbf{u}$  is to be determined. Differentiating (10.7.2) yields

$$\begin{aligned} \mathbf{y}'_p &= Y'\mathbf{u} + Y\mathbf{u}' \\ &= AY\mathbf{u} + Y\mathbf{u}' \quad (\text{since } Y' = AY) \\ &= A\mathbf{y}_p + Y\mathbf{u}' \quad (\text{since } Y\mathbf{u} = \mathbf{y}_p). \end{aligned}$$

Comparing this with (10.7.1) shows that  $\mathbf{y}_p = Y\mathbf{u}$  is a solution of (10.7.1) if and only if

$$Y\mathbf{u}' = \mathbf{f}.$$

Thus, we can find a particular solution  $\mathbf{y}_p$  by solving this equation for  $\mathbf{u}'$ , integrating to obtain  $\mathbf{u}$ , and computing  $Y\mathbf{u}$ . We can take all constants of integration to be zero, since any particular solution will suffice.

Exercise 22 sketches a proof that this method is analogous to the method of variation of parameters discussed in Sections 5.7 and 9.4 for scalar linear equations.

### Example 10.7.1

(a) Find a particular solution of the system

$$\mathbf{y}' = \begin{bmatrix} 1 & 2 \\ 2 & 1 \end{bmatrix} \mathbf{y} + \begin{bmatrix} 2e^{4t} \\ e^{4t} \end{bmatrix}, \quad (10.7.3)$$

which we considered in Example 10.2.1.

(b) Find the general solution of (10.7.3).

**SOLUTION(a)** The complementary system is

$$\mathbf{y}' = \begin{bmatrix} 1 & 2 \\ 2 & 1 \end{bmatrix} \mathbf{y}. \quad (10.7.4)$$

The characteristic polynomial of the coefficient matrix is

$$\begin{vmatrix} 1 - \lambda & 2 \\ 2 & 1 - \lambda \end{vmatrix} = (\lambda + 1)(\lambda - 3).$$

Using the method of Section 10.4, we find that

$$\mathbf{y}_1 = \begin{bmatrix} e^{3t} \\ e^{3t} \end{bmatrix} \quad \text{and} \quad \mathbf{y}_2 = \begin{bmatrix} e^{-t} \\ -e^{-t} \end{bmatrix}$$

are linearly independent solutions of (10.7.4). Therefore

$$Y = \begin{bmatrix} e^{3t} & e^{-t} \\ e^{3t} & -e^{-t} \end{bmatrix}$$

is a fundamental matrix for (10.7.4). We seek a particular solution  $\mathbf{y}_p = Y\mathbf{u}$  of (10.7.3), where  $Y\mathbf{u}' = \mathbf{f}$ ; that is,

$$\begin{bmatrix} e^{3t} & e^{-t} \\ e^{3t} & -e^{-t} \end{bmatrix} \begin{bmatrix} u'_1 \\ u'_2 \end{bmatrix} = \begin{bmatrix} 2e^{4t} \\ e^{4t} \end{bmatrix}.$$



The determinant of  $Y$  is the Wronskian

$$\begin{vmatrix} e^{3t} & e^{-t} \\ e^{3t} & -e^{-t} \end{vmatrix} = -2e^{2t}.$$

By Cramer's rule,

$$\begin{aligned} u_1' &= -\frac{1}{2e^{2t}} \begin{vmatrix} 2e^{4t} & e^{-t} \\ e^{4t} & -e^{-t} \end{vmatrix} = \frac{3e^{3t}}{2e^{2t}} = \frac{3}{2}e^t, \\ u_2' &= -\frac{1}{2e^{2t}} \begin{vmatrix} e^{3t} & 2e^{4t} \\ e^{3t} & e^{4t} \end{vmatrix} = \frac{e^{7t}}{2e^{2t}} = \frac{1}{2}e^{5t}. \end{aligned}$$

Therefore

$$\mathbf{u}' = \frac{1}{2} \begin{bmatrix} 3e^t \\ e^{5t} \end{bmatrix}.$$

Integrating and taking the constants of integration to be zero yields

$$\mathbf{u} = \frac{1}{10} \begin{bmatrix} 15e^t \\ e^{5t} \end{bmatrix},$$

so

$$\mathbf{y}_p = Y\mathbf{u} = \frac{1}{10} \begin{bmatrix} e^{3t} & e^{-t} \\ e^{3t} & -e^{-t} \end{bmatrix} \begin{bmatrix} 15e^t \\ e^{5t} \end{bmatrix} = \frac{1}{5} \begin{bmatrix} 8e^{4t} \\ 7e^{4t} \end{bmatrix}$$

is a particular solution of (10.7.3).

**SOLUTION(b)** From Theorem 10.7.1, the general solution of (10.7.3) is

$$\mathbf{y} = \mathbf{y}_p + c_1\mathbf{y}_1 + c_2\mathbf{y}_2 = \frac{1}{5} \begin{bmatrix} 8e^{4t} \\ 7e^{4t} \end{bmatrix} + c_1 \begin{bmatrix} e^{3t} \\ e^{3t} \end{bmatrix} + c_2 \begin{bmatrix} e^{-t} \\ -e^{-t} \end{bmatrix}, \quad (10.7.5)$$

which can also be written as

$$\mathbf{y} = \frac{1}{5} \begin{bmatrix} 8e^{4t} \\ 7e^{4t} \end{bmatrix} + \begin{bmatrix} e^{3t} & e^{-t} \\ e^{3t} & -e^{-t} \end{bmatrix} \mathbf{c},$$

where  $\mathbf{c}$  is an arbitrary constant vector.

Writing (10.7.5) in terms of coordinates yields

$$\begin{aligned} y_1 &= \frac{8}{5}e^{4t} + c_1e^{3t} + c_2e^{-t} \\ y_2 &= \frac{7}{5}e^{4t} + c_1e^{3t} - c_2e^{-t}, \end{aligned}$$

so our result is consistent with Example 10.2.1. ■

If  $A$  isn't a constant matrix, it's usually difficult to find a fundamental set of solutions for the system  $\mathbf{y}' = A(t)\mathbf{y}$ . It is beyond the scope of this text to discuss methods for doing this. Therefore, in the following examples and in the exercises involving systems with variable coefficient matrices we'll provide fundamental matrices for the complementary systems without explaining how they were obtained.

**Example 10.7.2** Find a particular solution of

$$\mathbf{y}' = \begin{bmatrix} 2 & 2e^{-2t} \\ 2e^{2t} & 4 \end{bmatrix} \mathbf{y} + \begin{bmatrix} 1 \\ 1 \end{bmatrix}, \quad (10.7.6)$$

given that

$$Y = \begin{bmatrix} e^{4t} & -1 \\ e^{6t} & e^{2t} \end{bmatrix}$$

is a fundamental matrix for the complementary system.

**Solution** We seek a particular solution  $\mathbf{y}_p = Y\mathbf{u}$  of (10.7.6) where  $Y\mathbf{u}' = \mathbf{f}$ ; that is,

$$\begin{bmatrix} e^{4t} & -1 \\ e^{6t} & e^{2t} \end{bmatrix} \begin{bmatrix} u'_1 \\ u'_2 \end{bmatrix} = \begin{bmatrix} 1 \\ 1 \end{bmatrix}.$$

The determinant of  $Y$  is the Wronskian

$$\begin{vmatrix} e^{4t} & -1 \\ e^{6t} & e^{2t} \end{vmatrix} = 2e^{6t}.$$

By Cramer's rule,

$$\begin{aligned} u'_1 &= \frac{1}{2e^{6t}} \begin{vmatrix} 1 & -1 \\ 1 & e^{2t} \end{vmatrix} = \frac{e^{2t} + 1}{2e^{6t}} = \frac{e^{-4t} + e^{-6t}}{2} \\ u'_2 &= \frac{1}{2e^{6t}} \begin{vmatrix} e^{4t} & 1 \\ e^{6t} & 1 \end{vmatrix} = \frac{e^{4t} - e^{6t}}{2e^{6t}} = \frac{e^{-2t} - 1}{2}. \end{aligned}$$

Therefore

$$\mathbf{u}' = \frac{1}{2} \begin{bmatrix} e^{-4t} + e^{-6t} \\ e^{-2t} - 1 \end{bmatrix}.$$

Integrating and taking the constants of integration to be zero yields

$$\mathbf{u} = -\frac{1}{24} \begin{bmatrix} 3e^{-4t} + 2e^{-6t} \\ 6e^{-2t} + 12t \end{bmatrix},$$

so

$$\mathbf{y}_p = Y\mathbf{u} = -\frac{1}{24} \begin{bmatrix} e^{4t} & -1 \\ e^{6t} & e^{2t} \end{bmatrix} \begin{bmatrix} 3e^{-4t} + 2e^{-6t} \\ 6e^{-2t} + 12t \end{bmatrix} = \frac{1}{24} \begin{bmatrix} 4e^{-2t} + 12t - 3 \\ -3e^{2t}(4t + 1) - 8 \end{bmatrix}$$

is a particular solution of (10.7.6).

**Example 10.7.3** Find a particular solution of

$$\mathbf{y}' = -\frac{2}{t^2} \begin{bmatrix} t & -3t^2 \\ 1 & -2t \end{bmatrix} \mathbf{y} + t^2 \begin{bmatrix} 1 \\ 1 \end{bmatrix}, \quad (10.7.7)$$

given that

$$Y = \begin{bmatrix} 2t & 3t^2 \\ 1 & 2t \end{bmatrix}$$

is a fundamental matrix for the complementary system on  $(-\infty, 0)$  and  $(0, \infty)$ .

**Solution** We seek a particular solution  $\mathbf{y}_p = Y\mathbf{u}$  of (10.7.7) where  $Y\mathbf{u}' = \mathbf{f}$ ; that is,

$$\begin{bmatrix} 2t & 3t^2 \\ 1 & 2t \end{bmatrix} \begin{bmatrix} u'_1 \\ u'_2 \end{bmatrix} = \begin{bmatrix} t^2 \\ t^2 \end{bmatrix}.$$

The determinant of  $Y$  is the Wronskian

$$\begin{vmatrix} 2t & 3t^2 \\ 1 & 2t \end{vmatrix} = t^2.$$

By Cramer's rule,

$$\begin{aligned} u_1' &= \frac{1}{t^2} \begin{vmatrix} t^2 & 3t^2 \\ t^2 & 2t \end{vmatrix} = \frac{2t^3 - 3t^4}{t^2} = 2t - 3t^2, \\ u_2' &= \frac{1}{t^2} \begin{vmatrix} 2t & t^2 \\ 1 & t^2 \end{vmatrix} = \frac{2t^3 - t^2}{t^2} = 2t - 1. \end{aligned}$$

Therefore

$$\mathbf{u}' = \begin{bmatrix} 2t - 3t^2 \\ 2t - 1 \end{bmatrix}.$$

Integrating and taking the constants of integration to be zero yields

$$\mathbf{u} = \begin{bmatrix} t^2 - t^3 \\ t^2 - t \end{bmatrix},$$

so

$$\mathbf{y}_p = Y\mathbf{u} = \begin{bmatrix} 2t & 3t^2 \\ 1 & 2t \end{bmatrix} \begin{bmatrix} t^2 - t^3 \\ t^2 - t \end{bmatrix} = \begin{bmatrix} t^3(t-1) \\ t^2(t-1) \end{bmatrix}$$

is a particular solution of (10.7.7).

#### Example 10.7.4

(a) Find a particular solution of

$$\mathbf{y}' = \begin{bmatrix} 2 & -1 & -1 \\ 1 & 0 & -1 \\ 1 & -1 & 0 \end{bmatrix} \mathbf{y} + \begin{bmatrix} e^t \\ 0 \\ e^{-t} \end{bmatrix}. \quad (10.7.8)$$

(b) Find the general solution of (10.7.8).

**SOLUTION(a)** The complementary system for (10.7.8) is

$$\mathbf{y}' = \begin{bmatrix} 2 & -1 & -1 \\ 1 & 0 & -1 \\ 1 & -1 & 0 \end{bmatrix} \mathbf{y}. \quad (10.7.9)$$

The characteristic polynomial of the coefficient matrix is

$$\begin{vmatrix} 2 - \lambda & -1 & -1 \\ 1 & -\lambda & -1 \\ 1 & -1 & -\lambda \end{vmatrix} = -\lambda(\lambda - 1)^2.$$

Using the method of Section 10.4, we find that

$$\mathbf{y}_1 = \begin{bmatrix} 1 \\ 1 \\ 1 \end{bmatrix}, \quad \mathbf{y}_2 = \begin{bmatrix} e^t \\ e^t \\ 0 \end{bmatrix}, \quad \text{and} \quad \mathbf{y}_3 = \begin{bmatrix} e^t \\ 0 \\ e^t \end{bmatrix}$$

are linearly independent solutions of (10.7.9). Therefore

$$Y = \begin{bmatrix} 1 & e^t & e^t \\ 1 & e^t & 0 \\ 1 & 0 & e^t \end{bmatrix}$$

is a fundamental matrix for (10.7.9). We seek a particular solution  $\mathbf{y}_p = Y\mathbf{u}$  of (10.7.8), where  $Y\mathbf{u}' = \mathbf{f}$ ; that is,

$$\begin{bmatrix} 1 & e^t & e^t \\ 1 & e^t & 0 \\ 1 & 0 & e^t \end{bmatrix} \begin{bmatrix} u'_1 \\ u'_2 \\ u'_3 \end{bmatrix} = \begin{bmatrix} e^t \\ 0 \\ e^{-t} \end{bmatrix}.$$

The determinant of  $Y$  is the Wronskian

$$\begin{vmatrix} 1 & e^t & e^t \\ 1 & e^t & 0 \\ 1 & 0 & e^t \end{vmatrix} = -e^{2t}.$$

Thus, by Cramer's rule,

$$\begin{aligned} u'_1 &= -\frac{1}{e^{2t}} \begin{vmatrix} e^t & e^t & e^t \\ 0 & e^t & 0 \\ e^{-t} & 0 & e^t \end{vmatrix} = -\frac{e^{3t} - e^t}{e^{2t}} = e^{-t} - e^t \\ u'_2 &= -\frac{1}{e^{2t}} \begin{vmatrix} 1 & e^t & e^t \\ 1 & 0 & 0 \\ 1 & e^{-t} & e^t \end{vmatrix} = -\frac{1 - e^{2t}}{e^{2t}} = 1 - e^{-2t} \\ u'_3 &= -\frac{1}{e^{2t}} \begin{vmatrix} 1 & e^t & e^t \\ 1 & e^t & 0 \\ 1 & 0 & e^{-t} \end{vmatrix} = \frac{e^{2t}}{e^{2t}} = 1. \end{aligned}$$

Therefore

$$\mathbf{u}' = \begin{bmatrix} e^{-t} - e^t \\ 1 - e^{-2t} \\ 1 \end{bmatrix}.$$

Integrating and taking the constants of integration to be zero yields

$$\mathbf{u} = \begin{bmatrix} -e^{-t} - e^{-t} \\ \frac{e^{-2t}}{2} + t \\ t \end{bmatrix},$$

so

$$\mathbf{y}_p = Y\mathbf{u} = \begin{bmatrix} 1 & e^t & e^t \\ 1 & e^t & 0 \\ 1 & 0 & e^t \end{bmatrix} \begin{bmatrix} -e^{-t} - e^{-t} \\ \frac{e^{-2t}}{2} + t \\ t \end{bmatrix} = \begin{bmatrix} e^t(2t - 1) - \frac{e^{-t}}{2} \\ e^t(t - 1) - \frac{e^{-t}}{2} \\ e^t(t - 1) - e^{-t} \end{bmatrix}$$

is a particular solution of (10.7.8).

**SOLUTION(a)** From Theorem 10.7.1 the general solution of (10.7.8) is

$$\mathbf{y} = \mathbf{y}_p + c_1\mathbf{y}_1 + c_2\mathbf{y}_2 + c_3\mathbf{y}_3 = \begin{bmatrix} e^t(2t-1) - \frac{e^{-t}}{2} \\ e^t(t-1) - \frac{e^{-t}}{2} \\ e^t(t-1) - e^{-t} \end{bmatrix} + c_1 \begin{bmatrix} 1 \\ 1 \\ 1 \end{bmatrix} + c_2 \begin{bmatrix} e^t \\ e^t \\ 0 \end{bmatrix} + c_3 \begin{bmatrix} e^t \\ 0 \\ e^t \end{bmatrix},$$

which can be written as

$$\mathbf{y} = \mathbf{y}_p + Y\mathbf{c} = \begin{bmatrix} e^t(2t-1) - \frac{e^{-t}}{2} \\ e^t(t-1) - \frac{e^{-t}}{2} \\ e^t(t-1) - e^{-t} \end{bmatrix} + \begin{bmatrix} 1 & e^t & e^t \\ 1 & e^t & 0 \\ 1 & 0 & e^t \end{bmatrix} \mathbf{c}$$

where  $\mathbf{c}$  is an arbitrary constant vector.

**Example 10.7.5** Find a particular solution of

$$\mathbf{y}' = \frac{1}{2} \begin{bmatrix} 3 & e^{-t} & -e^{2t} \\ 0 & 6 & 0 \\ -e^{-2t} & e^{-3t} & -1 \end{bmatrix} \mathbf{y} + \begin{bmatrix} 1 \\ e^t \\ e^{-t} \end{bmatrix}, \quad (10.7.10)$$

given that

$$Y = \begin{bmatrix} e^t & 0 & e^{2t} \\ 0 & e^{3t} & e^{3t} \\ e^{-t} & 1 & 0 \end{bmatrix}$$

is a fundamental matrix for the complementary system.

**Solution** We seek a particular solution of (10.7.10) in the form  $\mathbf{y}_p = Y\mathbf{u}$ , where  $Y\mathbf{u}' = \mathbf{f}$ ; that is,

$$\begin{bmatrix} e^t & 0 & e^{2t} \\ 0 & e^{3t} & e^{3t} \\ e^{-t} & 1 & 0 \end{bmatrix} \begin{bmatrix} u'_1 \\ u'_2 \\ u'_3 \end{bmatrix} = \begin{bmatrix} 1 \\ e^t \\ e^{-t} \end{bmatrix}.$$

The determinant of  $Y$  is the Wronskian

$$\begin{vmatrix} e^t & 0 & e^{2t} \\ 0 & e^{3t} & e^{3t} \\ e^{-t} & 1 & 0 \end{vmatrix} = -2e^{4t}.$$

By Cramer's rule,

$$\begin{aligned} u'_1 &= -\frac{1}{2e^{4t}} \begin{vmatrix} 1 & 0 & e^{2t} \\ e^t & e^{3t} & e^{3t} \\ e^{-t} & 1 & 0 \end{vmatrix} = \frac{e^{4t}}{2e^{4t}} = \frac{1}{2} \\ u'_2 &= -\frac{1}{2e^{4t}} \begin{vmatrix} e^t & 1 & e^{2t} \\ 0 & e^t & e^{3t} \\ e^{-t} & e^{-t} & 0 \end{vmatrix} = \frac{e^{3t}}{2e^{4t}} = \frac{1}{2}e^{-t} \\ u'_3 &= -\frac{1}{2e^{4t}} \begin{vmatrix} e^t & 0 & 1 \\ 0 & e^{3t} & e^t \\ e^{-t} & 1 & e^{-t} \end{vmatrix} = -\frac{e^{3t} - 2e^{2t}}{2e^{4t}} = \frac{2e^{-2t} - e^{-t}}{2}. \end{aligned}$$

Therefore

$$\mathbf{u}' = \frac{1}{2} \begin{bmatrix} 1 \\ e^{-t} \\ 2e^{-2t} - e^{-t} \end{bmatrix}.$$

Integrating and taking the constants of integration to be zero yields

$$\mathbf{u} = \frac{1}{2} \begin{bmatrix} t \\ -e^{-t} \\ e^{-t} - e^{-2t} \end{bmatrix},$$

so

$$\mathbf{y}_p = Y\mathbf{u} = \frac{1}{2} \begin{bmatrix} e^t & 0 & e^{2t} \\ 0 & e^{3t} & e^{3t} \\ e^{-t} & 1 & 0 \end{bmatrix} \begin{bmatrix} t \\ -e^{-t} \\ e^{-t} - e^{-2t} \end{bmatrix} = \frac{1}{2} \begin{bmatrix} e^t(t+1) - 1 \\ -e^t \\ e^{-t}(t-1) \end{bmatrix}$$

is a particular solution of (10.7.10).

### 10.7 Exercises

In Exercises 1–10 find a particular solution.

$$1. \quad \mathbf{y}' = \begin{bmatrix} -1 & -4 \\ -1 & -1 \end{bmatrix} \mathbf{y} + \begin{bmatrix} 21e^{4t} \\ 8e^{-3t} \end{bmatrix} \quad 2. \quad \mathbf{y}' = \frac{1}{5} \begin{bmatrix} -4 & 3 \\ -2 & -11 \end{bmatrix} \mathbf{y} + \begin{bmatrix} 50e^{3t} \\ 10e^{-3t} \end{bmatrix}$$

$$3. \quad \mathbf{y}' = \begin{bmatrix} 1 & 2 \\ 2 & 1 \end{bmatrix} \mathbf{y} + \begin{bmatrix} 1 \\ t \end{bmatrix} \quad 4. \quad \mathbf{y}' = \begin{bmatrix} -4 & -3 \\ 6 & 5 \end{bmatrix} \mathbf{y} + \begin{bmatrix} 2 \\ -2e^t \end{bmatrix}$$

$$5. \quad \mathbf{y}' = \begin{bmatrix} -6 & -3 \\ 1 & -2 \end{bmatrix} \mathbf{y} + \begin{bmatrix} 4e^{-3t} \\ 4e^{-5t} \end{bmatrix} \quad 6. \quad \mathbf{y}' = \begin{bmatrix} 0 & 1 \\ -1 & 0 \end{bmatrix} \mathbf{y} + \begin{bmatrix} 1 \\ t \end{bmatrix}$$

$$7. \quad \mathbf{y}' = \begin{bmatrix} 3 & 1 & -1 \\ 3 & 5 & 1 \\ -6 & 2 & 4 \end{bmatrix} \mathbf{y} + \begin{bmatrix} 3 \\ 6 \\ 3 \end{bmatrix} \quad 8. \quad \mathbf{y}' = \begin{bmatrix} 3 & -1 & -1 \\ -2 & 3 & 2 \\ 4 & -1 & -2 \end{bmatrix} \mathbf{y} + \begin{bmatrix} 1 \\ e^t \\ e^t \end{bmatrix}$$

$$9. \quad \mathbf{y}' = \begin{bmatrix} -3 & 2 & 2 \\ 2 & -3 & 2 \\ 2 & 2 & -3 \end{bmatrix} \mathbf{y} + \begin{bmatrix} e^t \\ e^{-5t} \\ e^t \end{bmatrix}$$

$$10. \quad \mathbf{y}' = \frac{1}{3} \begin{bmatrix} 1 & 1 & -3 \\ -4 & -4 & 3 \\ -2 & 1 & 0 \end{bmatrix} \mathbf{y} + \begin{bmatrix} e^t \\ e^t \\ e^t \end{bmatrix}$$

In Exercises 11–20 find a particular solution, given that  $Y$  is a fundamental matrix for the complementary system.

$$11. \quad \mathbf{y}' = \frac{1}{t} \begin{bmatrix} 1 & t \\ -t & 1 \end{bmatrix} \mathbf{y} + t \begin{bmatrix} \cos t \\ \sin t \end{bmatrix}; \quad Y = t \begin{bmatrix} \cos t & \sin t \\ -\sin t & \cos t \end{bmatrix}$$

$$12. \quad \mathbf{y}' = \frac{1}{t} \begin{bmatrix} 1 & t \\ t & 1 \end{bmatrix} \mathbf{y} + \begin{bmatrix} t \\ t^2 \end{bmatrix}; \quad Y = t \begin{bmatrix} e^t & e^{-t} \\ e^t & -e^{-t} \end{bmatrix}$$

13.  $\mathbf{y}' = \frac{1}{t^2 - 1} \begin{bmatrix} t & -1 \\ -1 & t \end{bmatrix} \mathbf{y} + t \begin{bmatrix} 1 \\ -1 \end{bmatrix}; \quad Y = \begin{bmatrix} t & 1 \\ 1 & t \end{bmatrix}$
14.  $\mathbf{y}' = \frac{1}{3} \begin{bmatrix} 1 & -2e^{-t} \\ 2e^t & -1 \end{bmatrix} \mathbf{y} + \begin{bmatrix} e^{2t} \\ e^{-2t} \end{bmatrix}; \quad Y = \begin{bmatrix} 2 & e^{-t} \\ e^t & 2 \end{bmatrix}$
15.  $\mathbf{y}' = \frac{1}{2t^4} \begin{bmatrix} 3t^3 & t^6 \\ 1 & -3t^3 \end{bmatrix} \mathbf{y} + \frac{1}{t} \begin{bmatrix} t^2 \\ 1 \end{bmatrix}; \quad Y = \frac{1}{t^2} \begin{bmatrix} t^3 & t^4 \\ -1 & t \end{bmatrix}$
16.  $\mathbf{y}' = \begin{bmatrix} \frac{1}{t-1} & -\frac{e^{-t}}{t-1} \\ \frac{e^t}{t+1} & \frac{1}{t+1} \end{bmatrix} \mathbf{y} + \begin{bmatrix} t^2 - 1 \\ t^2 - 1 \end{bmatrix}; \quad Y = \begin{bmatrix} t & e^{-t} \\ e^t & t \end{bmatrix}$
17.  $\mathbf{y}' = \frac{1}{t} \begin{bmatrix} 1 & 1 & 0 \\ 0 & 2 & 1 \\ -2 & 2 & 2 \end{bmatrix} \mathbf{y} + \begin{bmatrix} 1 \\ 2 \\ 1 \end{bmatrix}; \quad Y = \begin{bmatrix} t^2 & t^3 & 1 \\ t^2 & 2t^3 & -1 \\ 0 & 2t^3 & 2 \end{bmatrix}$
18.  $\mathbf{y}' = \begin{bmatrix} 3 & e^t & e^{2t} \\ e^{-t} & 2 & e^t \\ e^{-2t} & e^{-t} & 1 \end{bmatrix} \mathbf{y} + \begin{bmatrix} e^{3t} \\ 0 \\ 0 \end{bmatrix}; \quad Y = \begin{bmatrix} e^{5t} & e^{2t} & 0 \\ e^{4t} & 0 & e^t \\ e^{3t} & -1 & -1 \end{bmatrix}$
19.  $\mathbf{y}' = \frac{1}{t} \begin{bmatrix} 1 & t & 0 \\ 0 & 1 & t \\ 0 & -t & 1 \end{bmatrix} \mathbf{y} + \begin{bmatrix} t \\ t \\ t \end{bmatrix}; \quad Y = t \begin{bmatrix} 1 & \cos t & \sin t \\ 0 & -\sin t & \cos t \\ 0 & -\cos t & -\sin t \end{bmatrix}$
20.  $\mathbf{y}' = -\frac{1}{t} \begin{bmatrix} e^{-t} & -t & 1 - e^{-t} \\ e^{-t} & 1 & -t - e^{-t} \\ e^{-t} & -t & 1 - e^{-t} \end{bmatrix} \mathbf{y} + \frac{1}{t} \begin{bmatrix} e^t \\ 0 \\ e^t \end{bmatrix}; \quad Y = \frac{1}{t} \begin{bmatrix} e^t & e^{-t} & t \\ e^t & -e^{-t} & e^{-t} \\ e^t & e^{-t} & 0 \end{bmatrix}$

21. Prove Theorem 10.7.1.

22. (a) Convert the scalar equation

$$P_0(t)y^{(n)} + P_1(t)y^{(n-1)} + \cdots + P_n(t)y = F(t) \quad (\text{A})$$

into an equivalent  $n \times n$  system

$$\mathbf{y}' = A(t)\mathbf{y} + \mathbf{f}(t). \quad (\text{B})$$

(b) Suppose (A) is normal on an interval  $(a, b)$  and  $\{y_1, y_2, \dots, y_n\}$  is a fundamental set of solutions of

$$P_0(t)y^{(n)} + P_1(t)y^{(n-1)} + \cdots + P_n(t)y = 0 \quad (\text{C})$$

on  $(a, b)$ . Find a corresponding fundamental matrix  $Y$  for

$$\mathbf{y}' = A(t)\mathbf{y} \quad (\text{D})$$

on  $(a, b)$  such that

$$y = c_1y_1 + c_2y_2 + \cdots + c_ny_n$$

is a solution of (C) if and only if  $\mathbf{y} = Y\mathbf{c}$  with

$$\mathbf{c} = \begin{bmatrix} c_1 \\ c_2 \\ \vdots \\ c_n \end{bmatrix}$$

is a solution of (D).

- (c) Let  $y_p = u_1y_1 + u_2y_2 + \cdots + u_ny_n$  be a particular solution of (A), obtained by the method of variation of parameters for scalar equations as given in Section 9.4, and define

$$\mathbf{u} = \begin{bmatrix} u_1 \\ u_2 \\ \vdots \\ u_n \end{bmatrix}.$$

Show that  $\mathbf{y}_p = Y\mathbf{u}$  is a solution of (B).

- (d) Let  $\mathbf{y}_p = Y\mathbf{u}$  be a particular solution of (B), obtained by the method of variation of parameters for systems as given in this section. Show that  $y_p = u_1y_1 + u_2y_2 + \cdots + u_ny_n$  is a solution of (A).
23. Suppose the  $n \times n$  matrix function  $A$  and the  $n$ -vector function  $\mathbf{f}$  are continuous on  $(a, b)$ . Let  $t_0$  be in  $(a, b)$ , let  $\mathbf{k}$  be an arbitrary constant vector, and let  $Y$  be a fundamental matrix for the homogeneous system  $\mathbf{y}' = A(t)\mathbf{y}$ . Use variation of parameters to show that the solution of the initial value problem

$$\mathbf{y}' = A(t)\mathbf{y} + \mathbf{f}(t), \quad \mathbf{y}(t_0) = \mathbf{k}$$

is

$$\mathbf{y}(t) = Y(t) \left( Y^{-1}(t_0)\mathbf{k} + \int_{t_0}^t Y^{-1}(s)\mathbf{f}(s) ds \right).$$





# CHAPTER 11

## Boundary Value Problems and Fourier Expansions

IN THIS CHAPTER we develop series representations of functions that will be used to solve partial differential equations in Chapter 12.

SECTION 11.1 deals with five boundary value problems for the differential equation

$$y'' + \lambda y = 0.$$

They are related to problems in partial differential equations that will be discussed in Chapter 12. We define what is meant by eigenvalues and eigenfunctions of the boundary value problems, and show that the eigenfunctions have a property called *orthogonality*.

SECTION 11.2 introduces *Fourier series*, which are expansions of given functions in term of sines and cosines.

SECTION 11.3 deals with expansions of functions in terms of the eigenfunctions of four of the eigenvalue problems discussed in Section 11.1. They are all related to the Fourier series discussed in Section 11.2.

**11.1 EIGENVALUE PROBLEMS FOR  $y'' + \lambda y = 0$** 

In Chapter 12 we'll study partial differential equations that arise in problems of heat conduction, wave propagation, and potential theory. The purpose of this chapter is to develop tools required to solve these equations. In this section we consider the following problems, where  $\lambda$  is a real number and  $L > 0$ :

Problem 1:  $y'' + \lambda y = 0, \quad y(0) = 0, \quad y(L) = 0$

Problem 2:  $y'' + \lambda y = 0, \quad y'(0) = 0, \quad y'(L) = 0$

Problem 3:  $y'' + \lambda y = 0, \quad y(0) = 0, \quad y'(L) = 0$

Problem 4:  $y'' + \lambda y = 0, \quad y'(0) = 0, \quad y(L) = 0$

Problem 5:  $y'' + \lambda y = 0, \quad y(-L) = y(L), \quad y'(-L) = y'(L)$

In each problem the conditions following the differential equation are called *boundary conditions*. Note that the boundary conditions in Problem 5, unlike those in Problems 1-4, don't require that  $y$  or  $y'$  be zero at the boundary points, but only that  $y$  have the same value at  $x = \pm L$ , and that  $y'$  have the same value at  $x = \pm L$ . We say that the boundary conditions in Problem 5 are *periodic*.

Obviously,  $y \equiv 0$  (the trivial solution) is a solution of Problems 1-5 for any value of  $\lambda$ . For most values of  $\lambda$ , there are no other solutions. The interesting question is this:

*For what values of  $\lambda$  does the problem have nontrivial solutions, and what are they?*

A value of  $\lambda$  for which the problem has a nontrivial solution is an *eigenvalue* of the problem, and the nontrivial solutions are  $\lambda$ -*eigenfunctions*, or *eigenfunctions associated with  $\lambda$* . Note that a nonzero constant multiple of a  $\lambda$ -eigenfunction is again a  $\lambda$ -eigenfunction.

Problems 1-5 are called *eigenvalue problems*. *Solving* an eigenvalue problem means finding all its eigenvalues and associated eigenfunctions. We'll take it as given here that all the eigenvalues of Problems 1-5 are real numbers. This is proved in a more general setting in Section 13.2.

**Theorem 11.1.1** *Problems 1-5 have no negative eigenvalues. Moreover,  $\lambda = 0$  is an eigenvalue of Problems 2 and 5, with associated eigenfunction  $y_0 = 1$ , but  $\lambda = 0$  isn't an eigenvalue of Problems 1, 3, or 4.*

**Proof** We consider Problems 1-4, and leave Problem 5 to you (Exercise 1). If  $y'' + \lambda y = 0$ , then  $y(y'' + \lambda y) = 0$ , so

$$\int_0^L y(x)(y''(x) + \lambda y(x)) dx = 0;$$

therefore,

$$\lambda \int_0^L y^2(x) dx = - \int_0^L y(x)y''(x) dx. \quad (11.1.1)$$

Integration by parts yields

$$\begin{aligned} \int_0^L y(x)y''(x) dx &= y(x)y'(x) \Big|_0^L - \int_0^L (y'(x))^2 dx \\ &= y(L)y'(L) - y(0)y'(0) - \int_0^L (y'(x))^2 dx. \end{aligned} \quad (11.1.2)$$

However, if  $y$  satisfies any of the boundary conditions of Problems 1-4, then

$$y(L)y'(L) - y(0)y'(0) = 0;$$

hence, (11.1.1) and (11.1.2) imply that

$$\lambda \int_0^L y^2(x) dx = \int_0^L (y'(x))^2 dx.$$

If  $y \neq 0$ , then  $\int_0^L y^2(x) dx > 0$ . Therefore  $\lambda \geq 0$  and, if  $\lambda = 0$ , then  $y'(x) = 0$  for all  $x$  in  $(0, L)$  (why?), and  $y$  is constant on  $(0, L)$ . Any constant function satisfies the boundary conditions of Problem 2, so  $\lambda = 0$  is an eigenvalue of Problem 2 and any nonzero constant function is an associated eigenfunction. However, the only constant function that satisfies the boundary conditions of Problems 1, 3, or 4 is  $y \equiv 0$ . Therefore  $\lambda = 0$  isn't an eigenvalue of any of these problems.

**Example 11.1.1 (Problem 1)** Solve the eigenvalue problem

$$y'' + \lambda y = 0, \quad y(0) = 0, \quad y(L) = 0. \quad (11.1.3)$$

**Solution** From Theorem 11.1.1, any eigenvalues of (11.1.3) must be positive. If  $y$  satisfies (11.1.3) with  $\lambda > 0$ , then

$$y = c_1 \cos \sqrt{\lambda} x + c_2 \sin \sqrt{\lambda} x,$$

where  $c_1$  and  $c_2$  are constants. The boundary condition  $y(0) = 0$  implies that  $c_1 = 0$ . Therefore  $y = c_2 \sin \sqrt{\lambda} x$ . Now the boundary condition  $y(L) = 0$  implies that  $c_2 \sin \sqrt{\lambda} L = 0$ . To make  $c_2 \sin \sqrt{\lambda} L = 0$  with  $c_2 \neq 0$ , we must choose  $\sqrt{\lambda} = n\pi/L$ , where  $n$  is a positive integer. Therefore  $\lambda_n = n^2\pi^2/L^2$  is an eigenvalue and

$$y_n = \sin \frac{n\pi x}{L}$$

is an associated eigenfunction. ■

For future reference, we state the result of Example 11.1.1 as a theorem.

**Theorem 11.1.2** *The eigenvalue problem*

$$y'' + \lambda y = 0, \quad y(0) = 0, \quad y(L) = 0$$

*has infinitely many positive eigenvalues  $\lambda_n = n^2\pi^2/L^2$ , with associated eigenfunctions*

$$y_n = \sin \frac{n\pi x}{L}, \quad n = 1, 2, 3, \dots$$

*There are no other eigenvalues.*

We leave it to you to prove the next theorem about Problem 2 by an argument like that of Example 11.1.1 (Exercise 17).

**Theorem 11.1.3** *The eigenvalue problem*

$$y'' + \lambda y = 0, \quad y'(0) = 0, \quad y'(L) = 0$$

*has the eigenvalue  $\lambda_0 = 0$ , with associated eigenfunction  $y_0 = 1$ , and infinitely many positive eigenvalues  $\lambda_n = n^2\pi^2/L^2$ , with associated eigenfunctions*

$$y_n = \cos \frac{n\pi x}{L}, \quad n = 1, 2, 3, \dots$$

*There are no other eigenvalues.*

**Example 11.1.2 (Problem 3)** Solve the eigenvalue problem

$$y'' + \lambda y = 0, \quad y(0) = 0, \quad y'(L) = 0. \quad (11.1.4)$$

**Solution** From Theorem 11.1.1, any eigenvalues of (11.1.4) must be positive. If  $y$  satisfies (11.1.4) with  $\lambda > 0$ , then

$$y = c_1 \cos \sqrt{\lambda} x + c_2 \sin \sqrt{\lambda} x,$$

where  $c_1$  and  $c_2$  are constants. The boundary condition  $y(0) = 0$  implies that  $c_1 = 0$ . Therefore  $y = c_2 \sin \sqrt{\lambda} x$ . Hence,  $y' = c_2 \sqrt{\lambda} \cos \sqrt{\lambda} x$  and the boundary condition  $y'(L) = 0$  implies that  $c_2 \cos \sqrt{\lambda} L = 0$ . To make  $c_2 \cos \sqrt{\lambda} L = 0$  with  $c_2 \neq 0$  we must choose

$$\sqrt{\lambda} = \frac{(2n-1)\pi}{2L},$$

where  $n$  is a positive integer. Then  $\lambda_n = (2n-1)^2 \pi^2 / 4L^2$  is an eigenvalue and

$$y_n = \sin \frac{(2n-1)\pi x}{2L}$$

is an associated eigenfunction. ■

For future reference, we state the result of Example 11.1.2 as a theorem.

**Theorem 11.1.4** *The eigenvalue problem*

$$y'' + \lambda y = 0, \quad y(0) = 0, \quad y'(L) = 0$$

*has infinitely many positive eigenvalues  $\lambda_n = (2n-1)^2 \pi^2 / 4L^2$ , with associated eigenfunctions*

$$y_n = \sin \frac{(2n-1)\pi x}{2L}, \quad n = 1, 2, 3, \dots$$

*There are no other eigenvalues.*

We leave it to you to prove the next theorem about Problem 4 by an argument like that of Example 11.1.2 (Exercise 18).

**Theorem 11.1.5** *The eigenvalue problem*

$$y'' + \lambda y = 0, \quad y'(0) = 0, \quad y(L) = 0$$

*has infinitely many positive eigenvalues  $\lambda_n = (2n-1)^2 \pi^2 / 4L^2$ , with associated eigenfunctions*

$$y_n = \cos \frac{(2n-1)\pi x}{2L}, \quad n = 1, 2, 3, \dots$$

*There are no other eigenvalues.*

**Example 11.1.3 (Problem 5)** Solve the eigenvalue problem

$$y'' + \lambda y = 0, \quad y(-L) = y(L), \quad y'(-L) = y'(L). \quad (11.1.5)$$

**Solution** From Theorem 11.1.1,  $\lambda = 0$  is an eigenvalue of (11.1.5) with associated eigenfunction  $y_0 = 1$ , and any other eigenvalues must be positive. If  $y$  satisfies (11.1.5) with  $\lambda > 0$ , then

$$y = c_1 \cos \sqrt{\lambda} x + c_2 \sin \sqrt{\lambda} x, \quad (11.1.6)$$

where  $c_1$  and  $c_2$  are constants. The boundary condition  $y(-L) = y(L)$  implies that

$$c_1 \cos(-\sqrt{\lambda} L) + c_2 \sin(-\sqrt{\lambda} L) = c_1 \cos \sqrt{\lambda} L + c_2 \sin \sqrt{\lambda} L. \quad (11.1.7)$$

Since

$$\cos(-\sqrt{\lambda} L) = \cos \sqrt{\lambda} L \quad \text{and} \quad \sin(-\sqrt{\lambda} L) = -\sin \sqrt{\lambda} L, \quad (11.1.8)$$

(11.1.7) implies that

$$c_2 \sin \sqrt{\lambda} L = 0. \quad (11.1.9)$$

Differentiating (11.1.6) yields

$$y' = \sqrt{\lambda} (-c_1 \sin \sqrt{\lambda} x + c_2 \cos \sqrt{\lambda} x).$$

The boundary condition  $y'(-L) = y'(L)$  implies that

$$-c_1 \sin(-\sqrt{\lambda} L) + c_2 \cos(-\sqrt{\lambda} L) = -c_1 \sin \sqrt{\lambda} L + c_2 \cos \sqrt{\lambda} L,$$

and (11.1.8) implies that

$$c_1 \sin \sqrt{\lambda} L = 0. \quad (11.1.10)$$

Eqns. (11.1.9) and (11.1.10) imply that  $c_1 = c_2 = 0$  unless  $\sqrt{\lambda} = n\pi/L$ , where  $n$  is a positive integer. In this case (11.1.9) and (11.1.10) both hold for arbitrary  $c_1$  and  $c_2$ . The eigenvalue determined in this way is  $\lambda_n = n^2\pi^2/L^2$ , and each such eigenvalue has the linearly independent associated eigenfunctions

$$\cos \frac{n\pi x}{L} \quad \text{and} \quad \sin \frac{n\pi x}{L}. \quad \blacksquare$$

For future reference we state the result of Example 11.1.3 as a theorem.

**Theorem 11.1.6** *The eigenvalue problem*

$$y'' + \lambda y = 0, \quad y(-L) = y(L), \quad y'(-L) = y'(L),$$

has the eigenvalue  $\lambda_0 = 0$ , with associated eigenfunction  $y_0 = 1$  and infinitely many positive eigenvalues  $\lambda_n = n^2\pi^2/L^2$ , with associated eigenfunctions

$$y_{1n} = \cos \frac{n\pi x}{L} \quad \text{and} \quad y_{2n} = \sin \frac{n\pi x}{L}, \quad n = 1, 2, 3, \dots$$

There are no other eigenvalues.

**Orthogonality**

We say that two integrable functions  $f$  and  $g$  are *orthogonal* on an interval  $[a, b]$  if

$$\int_a^b f(x)g(x) dx = 0.$$

More generally, we say that the functions  $\phi_1, \phi_2, \dots, \phi_n, \dots$  (finitely or infinitely many) are orthogonal on  $[a, b]$  if

$$\int_a^b \phi_i(x)\phi_j(x) dx = 0 \quad \text{whenever} \quad i \neq j.$$

The importance of orthogonality will become clear when we study Fourier series in the next two sections.

**Example 11.1.4** Show that the eigenfunctions

$$1, \cos \frac{\pi x}{L}, \sin \frac{\pi x}{L}, \cos \frac{2\pi x}{L}, \sin \frac{2\pi x}{L}, \dots, \cos \frac{n\pi x}{L}, \sin \frac{n\pi x}{L}, \dots \quad (11.1.11)$$

of Problem 5 are orthogonal on  $[-L, L]$ .

**Solution** We must show that

$$\int_{-L}^L f(x)g(x) dx = 0 \quad (11.1.12)$$

whenever  $f$  and  $g$  are distinct functions from (11.1.11). If  $r$  is any nonzero integer, then

$$\int_{-L}^L \cos \frac{r\pi x}{L} dx = \frac{L}{r\pi} \sin \frac{r\pi x}{L} \Big|_{-L}^L = 0. \quad (11.1.13)$$

and

$$\int_{-L}^L \sin \frac{r\pi x}{L} dx = -\frac{L}{r\pi} \cos \frac{r\pi x}{L} \Big|_{-L}^L = 0.$$

Therefore (11.1.12) holds if  $f \equiv 1$  and  $g$  is any other function in (11.1.11).

If  $f(x) = \cos m\pi x/L$  and  $g(x) = \cos n\pi x/L$  where  $m$  and  $n$  are distinct positive integers, then

$$\int_{-L}^L f(x)g(x) dx = \int_{-L}^L \cos \frac{m\pi x}{L} \cos \frac{n\pi x}{L} dx. \quad (11.1.14)$$

To evaluate this integral, we use the identity

$$\cos A \cos B = \frac{1}{2}[\cos(A - B) + \cos(A + B)]$$

with  $A = m\pi x/L$  and  $B = n\pi x/L$ . Then (11.1.14) becomes

$$\int_{-L}^L f(x)g(x) dx = \frac{1}{2} \left[ \int_{-L}^L \cos \frac{(m-n)\pi x}{L} dx + \int_{-L}^L \cos \frac{(m+n)\pi x}{L} dx \right].$$

Since  $m - n$  and  $m + n$  are both nonzero integers, (11.1.13) implies that the integrals on the right are both zero. Therefore (11.1.12) is true in this case.

If  $f(x) = \sin m\pi x/L$  and  $g(x) = \sin n\pi x/L$  where  $m$  and  $n$  are distinct positive integers, then

$$\int_{-L}^L f(x)g(x) dx = \int_{-L}^L \sin \frac{m\pi x}{L} \sin \frac{n\pi x}{L} dx. \quad (11.1.15)$$

To evaluate this integral, we use the identity

$$\sin A \sin B = \frac{1}{2}[\cos(A - B) - \cos(A + B)]$$

with  $A = m\pi x/L$  and  $B = n\pi x/L$ . Then (11.1.15) becomes

$$\int_{-L}^L f(x)g(x) dx = \frac{1}{2} \left[ \int_{-L}^L \cos \frac{(m-n)\pi x}{L} dx - \int_{-L}^L \cos \frac{(m+n)\pi x}{L} dx \right] = 0.$$

If  $f(x) = \sin m\pi x/L$  and  $g(x) = \cos n\pi x/L$  where  $m$  and  $n$  are positive integers (not necessarily distinct), then

$$\int_{-L}^L f(x)g(x) dx = \int_{-L}^L \sin \frac{m\pi x}{L} \cos \frac{n\pi x}{L} dx = 0$$

because the integrand is an odd function and the limits are symmetric about  $x = 0$ . ■

Exercises 19-22 ask you to verify that the eigenfunctions of Problems 1-4 are orthogonal on  $[0, L]$ . However, this also follows from a general theorem that we'll prove in Chapter 13.

## 11.1 Exercises

---

1. Prove that  $\lambda = 0$  is an eigenvalue of Problem 5 with associated eigenfunction  $y_0 = 1$ , and that any other eigenvalues must be positive. HINT: See the proof of Theorem 11.1.1.

In Exercises 2-16 solve the eigenvalue problem.

2.  $y'' + \lambda y = 0$ ,  $y(0) = 0$ ,  $y(\pi) = 0$
3.  $y'' + \lambda y = 0$ ,  $y'(0) = 0$ ,  $y'(\pi) = 0$
4.  $y'' + \lambda y = 0$ ,  $y(0) = 0$ ,  $y'(\pi) = 0$
5.  $y'' + \lambda y = 0$ ,  $y'(0) = 0$ ,  $y(\pi) = 0$
6.  $y'' + \lambda y = 0$ ,  $y(-\pi) = y(\pi)$ ,  $y'(-\pi) = y'(\pi)$
7.  $y'' + \lambda y = 0$ ,  $y'(0) = 0$ ,  $y'(1) = 0$
8.  $y'' + \lambda y = 0$ ,  $y'(0) = 0$ ,  $y(1) = 0$
9.  $y'' + \lambda y = 0$ ,  $y(0) = 0$ ,  $y(1) = 0$
10.  $y'' + \lambda y = 0$ ,  $y(-1) = y(1)$ ,  $y'(-1) = y'(1)$
11.  $y'' + \lambda y = 0$ ,  $y(0) = 0$ ,  $y'(1) = 0$
12.  $y'' + \lambda y = 0$ ,  $y(-2) = y(2)$ ,  $y'(-2) = y'(2)$
13.  $y'' + \lambda y = 0$ ,  $y(0) = 0$ ,  $y(2) = 0$
14.  $y'' + \lambda y = 0$ ,  $y'(0) = 0$ ,  $y(3) = 0$
15.  $y'' + \lambda y = 0$ ,  $y(0) = 0$ ,  $y'(1/2) = 0$
16.  $y'' + \lambda y = 0$ ,  $y'(0) = 0$ ,  $y'(5) = 0$
17. Prove Theorem 11.1.3.
18. Prove Theorem 11.1.5.
19. Verify that the eigenfunctions

$$\sin \frac{\pi x}{L}, \sin \frac{2\pi x}{L}, \dots, \sin \frac{n\pi x}{L}, \dots$$

of Problem 1 are orthogonal on  $[0, L]$ .

20. Verify that the eigenfunctions

$$1, \cos \frac{\pi x}{L}, \cos \frac{2\pi x}{L}, \dots, \cos \frac{n\pi x}{L}, \dots$$

of Problem 2 are orthogonal on  $[0, L]$ .



21. Verify that the eigenfunctions

$$\sin \frac{\pi x}{2L}, \sin \frac{3\pi x}{2L}, \dots, \sin \frac{(2n-1)\pi x}{2L}, \dots$$

of Problem 3 are orthogonal on  $[0, L]$ .

22. Verify that the eigenfunctions

$$\cos \frac{\pi x}{2L}, \cos \frac{3\pi x}{2L}, \dots, \cos \frac{(2n-1)\pi x}{2L}, \dots$$

of Problem 4 are orthogonal on  $[0, L]$ .

In Exercises 23-26 solve the eigenvalue problem.

$$23. \quad y'' + \lambda y = 0, \quad y(0) = 0, \quad \int_0^L y(x) dx = 0$$

$$24. \quad y'' + \lambda y = 0, \quad y'(0) = 0, \quad \int_0^L y(x) dx = 0$$

$$25. \quad y'' + \lambda y = 0, \quad y(L) = 0, \quad \int_0^L y(x) dx = 0$$

$$26. \quad y'' + \lambda y = 0, \quad y'(L) = 0, \quad \int_0^L y(x) dx = 0$$

## 11.2 FOURIER EXPANSIONS I

In Example 11.1.4 and Exercises 11.1.4–11.1.22 we saw that the eigenfunctions of Problem 5 are orthogonal on  $[-L, L]$  and the eigenfunctions of Problems 1–4 are orthogonal on  $[0, L]$ . In this section and the next we introduce some series expansions in terms of these eigenfunctions. We'll use these expansions to solve partial differential equations in Chapter 12.

**Theorem 11.2.1** *Suppose the functions  $\phi_1, \phi_2, \phi_3, \dots$ , are orthogonal on  $[a, b]$  and*

$$\int_a^b \phi_n^2(x) dx \neq 0, \quad n = 1, 2, 3, \dots \quad (11.2.1)$$

*Let  $c_1, c_2, c_3, \dots$  be constants such that the partial sums  $f_N(x) = \sum_{m=1}^N c_m \phi_m(x)$  satisfy the inequalities*

$$|f_N(x)| \leq M, \quad a \leq x \leq b, \quad N = 1, 2, 3, \dots$$

*for some constant  $M < \infty$ . Suppose also that the series*

$$f(x) = \sum_{m=1}^{\infty} c_m \phi_m(x) \quad (11.2.2)$$

*converges and is integrable on  $[a, b]$ . Then*

$$c_n = \frac{\int_a^b f(x) \phi_n(x) dx}{\int_a^b \phi_n^2(x) dx}, \quad n = 1, 2, 3, \dots \quad (11.2.3)$$

**Proof** Multiplying (11.2.2) by  $\phi_n$  and integrating yields

$$\int_a^b f(x)\phi_n(x) dx = \int_a^b \phi_n(x) \left( \sum_{m=1}^{\infty} c_m \phi_m(x) \right) dx. \quad (11.2.4)$$

It can be shown that the boundedness of the partial sums  $\{f_N\}_{N=1}^{\infty}$  and the integrability of  $f$  allow us to interchange the operations of integration and summation on the right of (11.2.4), and rewrite (11.2.4) as

$$\int_a^b f(x)\phi_n(x) dx = \sum_{m=1}^{\infty} c_m \int_a^b \phi_n(x)\phi_m(x) dx. \quad (11.2.5)$$

(This isn't easy to prove.) Since

$$\int_a^b \phi_n(x)\phi_m(x) dx = 0 \quad \text{if } m \neq n,$$

(11.2.5) reduces to

$$\int_a^b f(x)\phi_n(x) dx = c_n \int_a^b \phi_n^2(x) dx.$$

Now (11.2.1) implies (11.2.3). ■

Theorem 11.2.1 motivates the next definition.

**Definition 11.2.2** Suppose  $\phi_1, \phi_2, \dots, \phi_n, \dots$  are orthogonal on  $[a, b]$  and  $\int_a^b \phi_n^2(x) dx \neq 0, n = 1, 2, 3, \dots$ . Let  $f$  be integrable on  $[a, b]$ , and define

$$c_n = \frac{\int_a^b f(x)\phi_n(x) dx}{\int_a^b \phi_n^2(x) dx}, \quad n = 1, 2, 3, \dots \quad (11.2.6)$$

Then the infinite series  $\sum_{n=1}^{\infty} c_n \phi_n(x)$  is called the *Fourier expansion of  $f$  in terms of the orthogonal set  $\{\phi_n\}_{n=1}^{\infty}$* , and  $c_1, c_2, \dots, c_n, \dots$  are called the *Fourier coefficients of  $f$  with respect to  $\{\phi_n\}_{n=1}^{\infty}$* . We indicate the relationship between  $f$  and its Fourier expansion by

$$f(x) \sim \sum_{n=1}^{\infty} c_n \phi_n(x), \quad a \leq x \leq b. \quad (11.2.7)$$

You may wonder why we don't write

$$f(x) = \sum_{n=1}^{\infty} c_n \phi_n(x), \quad a \leq x \leq b,$$

rather than (11.2.7). Unfortunately, this isn't always true. The series on the right may diverge for some or all values of  $x$  in  $[a, b]$ , or it may converge to  $f(x)$  for some values of  $x$  and not for others. So, for now, we'll just think of the series as being associated with  $f$  because of the definition of the coefficients  $\{c_n\}$ , and we'll indicate this association informally as in (11.2.7).

### Fourier Series

We'll now study Fourier expansions in terms of the eigenfunctions

$$1, \cos \frac{\pi x}{L}, \sin \frac{\pi x}{L}, \cos \frac{2\pi x}{L}, \sin \frac{2\pi x}{L}, \dots, \cos \frac{n\pi x}{L}, \sin \frac{n\pi x}{L}, \dots$$

of Problem 5. If  $f$  is integrable on  $[-L, L]$ , its Fourier expansion in terms of these functions is called the *Fourier series of  $f$  on  $[-L, L]$* . Since

$$\int_{-L}^L 1^2 dx = 2L,$$

$$\int_{-L}^L \cos^2 \frac{n\pi x}{L} dx = \frac{1}{2} \int_{-L}^L \left(1 + \cos \frac{2n\pi x}{L}\right) dx = \frac{1}{2} \left(x + \frac{L}{2n\pi} \sin \frac{2n\pi x}{L}\right) \Big|_{-L}^L = L,$$

and

$$\int_{-L}^L \sin^2 \frac{n\pi x}{L} dx = \frac{1}{2} \int_{-L}^L \left(1 - \cos \frac{2n\pi x}{L}\right) dx = \frac{1}{2} \left(x - \frac{L}{2n\pi} \sin \frac{2n\pi x}{L}\right) \Big|_{-L}^L = L,$$

we see from (11.2.6) that the Fourier series of  $f$  on  $[-L, L]$  is

$$a_0 + \sum_{n=1}^{\infty} \left( a_n \cos \frac{n\pi x}{L} + b_n \sin \frac{n\pi x}{L} \right),$$

where

$$a_0 = \frac{1}{2L} \int_{-L}^L f(x) dx,$$

$$a_n = \frac{1}{L} \int_{-L}^L f(x) \cos \frac{n\pi x}{L} dx, \quad \text{and} \quad b_n = \frac{1}{L} \int_{-L}^L f(x) \sin \frac{n\pi x}{L} dx, \quad n \geq 1.$$

Note that  $a_0$  is the average value of  $f$  on  $[-L, L]$ , while  $a_n$  and  $b_n$  (for  $n \geq 1$ ) are twice the average values of

$$f(x) \cos \frac{n\pi x}{L} \quad \text{and} \quad f(x) \sin \frac{n\pi x}{L}$$

on  $[-L, L]$ , respectively.

### Convergence of Fourier Series

The question of convergence of Fourier series for arbitrary integrable functions is beyond the scope of this book. However, we can state a theorem that settles this question for most functions that arise in applications.

**Definition 11.2.3** A function  $f$  is said to be *piecewise smooth* on  $[a, b]$  if:

- (a)  $f$  has at most finitely many points of discontinuity in  $(a, b)$ ;
- (b)  $f'$  exists and is continuous except possibly at finitely many points in  $(a, b)$ ;
- (c)  $f(x_0+) = \lim_{x \rightarrow x_0+} f(x)$  and  $f'(x_0+) = \lim_{x \rightarrow x_0+} f'(x)$  exist if  $a \leq x_0 < b$ ;
- (d)  $f(x_0-) = \lim_{x \rightarrow x_0-} f(x)$  and  $f'(x_0-) = \lim_{x \rightarrow x_0-} f'(x)$  exist if  $a < x_0 \leq b$ .

Since  $f$  and  $f'$  are required to be continuous at all but finitely many points in  $[a, b]$ ,  $f(x_0+) = f(x_0-)$  and  $f'(x_0+) = f'(x_0-)$  for all but finitely many values of  $x_0$  in  $(a, b)$ . Recall from Section 8.1 that  $f$  is said to have a *jump discontinuity* at  $x_0$  if  $f(x_0+) \neq f(x_0-)$ .

The next theorem gives sufficient conditions for convergence of a Fourier series. The proof is beyond the scope of this book.

**Theorem 11.2.4** *If  $f$  is piecewise smooth on  $[-L, L]$ , then the Fourier series*

$$F(x) = a_0 + \sum_{n=1}^{\infty} \left( a_n \cos \frac{n\pi x}{L} + b_n \sin \frac{n\pi x}{L} \right) \quad (11.2.8)$$

*of  $f$  on  $[-L, L]$  converges for all  $x$  in  $[-L, L]$ ; moreover,*

$$F(x) = \begin{cases} f(x) & \text{if } -L < x < L \text{ and } f \text{ is continuous at } x \\ \frac{f(x-) + f(x+)}{2} & \text{if } -L < x < L \text{ and } f \text{ is discontinuous at } x \\ \frac{f(-L+) + f(L-)}{2} & \text{if } x = L \text{ or } x = -L. \end{cases}$$

Since  $f(x+) = f(x-)$  if  $f$  is continuous at  $x$ , we can also say that

$$F(x) = \begin{cases} \frac{f(x+) + f(x-)}{2} & \text{if } -L < x < L, \\ \frac{f(L-) + f(-L+)}{2} & \text{if } x = \pm L. \end{cases}$$

Note that  $F$  is itself piecewise smooth on  $[-L, L]$ , and  $F(x) = f(x)$  at all points in the open interval  $(-L, L)$  where  $f$  is continuous. Since the series in (11.2.8) converges to  $F(x)$  for all  $x$  in  $[-L, L]$ , you may be tempted to infer that the error

$$E_N(x) = \left| F(x) - a_0 - \sum_{n=1}^N \left( a_n \cos \frac{n\pi x}{L} + b_n \sin \frac{n\pi x}{L} \right) \right|$$

can be made as small as we please for all  $x$  in  $[-L, L]$  by choosing  $N$  sufficiently large. However, this isn't true if  $f$  has a discontinuity somewhere in  $(-L, L)$ , or if  $f(-L+) \neq f(L-)$ . Here's the situation in this case.

*If  $f$  has a jump discontinuity at a point  $\alpha$  in  $(-L, L)$ , there will be sequences of points  $\{u_N\}$  and  $\{v_N\}$  in  $(-L, \alpha)$  and  $(\alpha, L)$ , respectively, such that*

$$\lim_{N \rightarrow \infty} u_N = \lim_{N \rightarrow \infty} v_N = \alpha$$

and

$$E_N(u_N) \approx .09|f(\alpha-) - f(\alpha+)| \quad \text{and} \quad E_N(v_N) \approx .09|f(\alpha-) - f(\alpha+)|.$$

*Thus, the maximum value of the error  $E_N(x)$  near  $\alpha$  does not approach zero as  $N \rightarrow \infty$ , but just occurs closer and closer to (and on both sides of)  $\alpha$ , and is essentially independent of  $N$ .*

*If  $f(-L+) \neq f(L-)$ , then there will be sequences of points  $\{u_N\}$  and  $\{v_N\}$  in  $(-L, L)$  such that*

$$\lim_{N \rightarrow \infty} u_N = -L, \quad \lim_{N \rightarrow \infty} v_N = L,$$

$$E_N(u_N) \approx .09|f(-L+) - f(L-)| \quad \text{and} \quad E_N(v_N) \approx .09|f(-L+) - f(L-)|.$$

This is the *Gibbs phenomenon*. Having been alerted to it, you may see it in Figures 11.2.2–11.2.4, below; however, we'll give a specific example at the end of this section.

**Example 11.2.1** Find the Fourier series of the piecewise smooth function

$$f(x) = \begin{cases} -x, & -2 < x < 0, \\ \frac{1}{2}, & 0 < x < 2 \end{cases}$$

on  $[-2, 2]$  (Figure 11.2.1). Determine the sum of the Fourier series for  $-2 \leq x \leq 2$ .

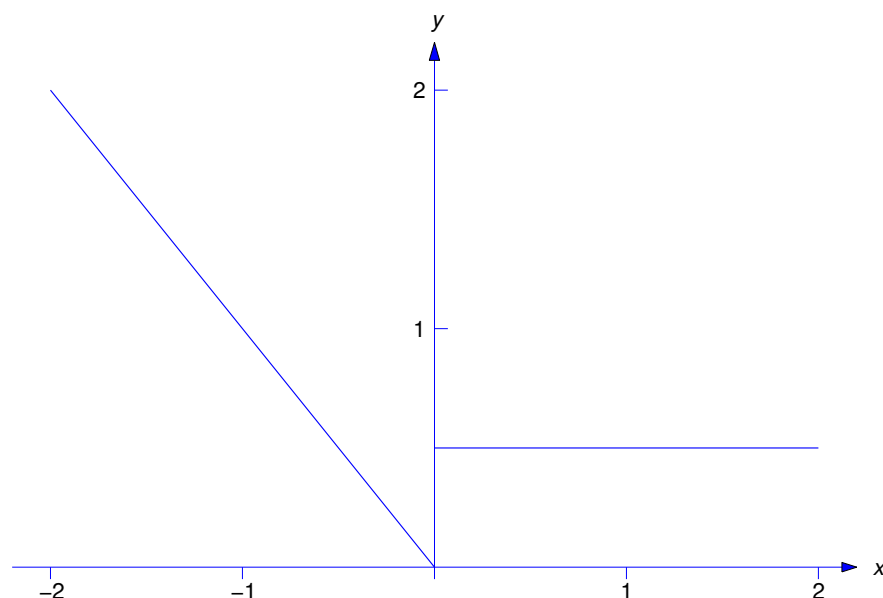

Figure 11.2.1

**Solution** Note that we aren't bothered to define  $f(-2)$ ,  $f(0)$ , and  $f(2)$ . No matter how they may be defined,  $f$  is piecewise smooth on  $[-2, 2]$ , and the coefficients in the Fourier series

$$F(x) = a_0 + \sum_{n=1}^{\infty} \left( a_n \cos \frac{n\pi x}{2} + b_n \sin \frac{n\pi x}{2} \right)$$

are not affected by them. In any case, Theorem 11.2.4 implies that  $F(x) = f(x)$  in  $(-2, 0)$  and  $(0, 2)$ , where  $f$  is continuous, while

$$F(-2) = F(2) = \frac{f(-2+) + f(2-)}{2} = \frac{1}{2} \left( 2 + \frac{1}{2} \right) = \frac{5}{4}$$

and

$$F(0) = \frac{f(0-) + f(0+)}{2} = \frac{1}{2} \left( 0 + \frac{1}{2} \right) = \frac{1}{4}.$$

To summarize,

$$F(x) = \begin{cases} \frac{5}{4}, & x = -2 \\ -x, & -2 < x < 0, \\ \frac{1}{4}, & x = 0, \\ \frac{1}{2}, & 0 < x < 2, \\ \frac{5}{4}, & x = 2. \end{cases}$$

We compute the Fourier coefficients as follows:

$$a_0 = \frac{1}{4} \int_{-2}^2 f(x) dx = \frac{1}{4} \left[ \int_{-2}^0 (-x) dx + \int_0^2 \frac{1}{2} dx \right] = \frac{3}{4}.$$

If  $n \geq 1$ , then

$$\begin{aligned} a_n &= \frac{1}{2} \int_{-2}^2 f(x) \cos \frac{n\pi x}{2} dx = \frac{1}{2} \left[ \int_{-2}^0 (-x) \cos \frac{n\pi x}{2} dx + \int_0^2 \frac{1}{2} \cos \frac{n\pi x}{2} dx \right] \\ &= \frac{2}{n^2 \pi^2} (\cos n\pi - 1), \end{aligned}$$

and

$$\begin{aligned} b_n &= \frac{1}{2} \int_{-2}^2 f(x) \sin \frac{n\pi x}{2} dx = \frac{1}{2} \left[ \int_{-2}^0 (-x) \sin \frac{n\pi x}{2} dx + \int_0^2 \frac{1}{2} \sin \frac{n\pi x}{2} dx \right] \\ &= \frac{1}{2n\pi} (1 + 3 \cos n\pi). \end{aligned}$$

Therefore

$$F(x) = \frac{3}{4} + \frac{2}{\pi^2} \sum_{n=1}^{\infty} \frac{\cos n\pi - 1}{n^2} \cos \frac{n\pi x}{2} + \frac{1}{2\pi} \sum_{n=1}^{\infty} \frac{1 + 3 \cos n\pi}{n} \sin \frac{n\pi x}{2}.$$

Figure 11.2.2 shows how the partial sum

$$F_m(x) = \frac{3}{4} + \frac{2}{\pi^2} \sum_{n=1}^m \frac{\cos n\pi - 1}{n^2} \cos \frac{n\pi x}{2} + \frac{1}{2\pi} \sum_{n=1}^m \frac{1 + 3 \cos n\pi}{n} \sin \frac{n\pi x}{2}$$

approximates  $f(x)$  for  $m = 5$  (dotted curve),  $m = 10$  (dashed curve), and  $m = 15$  (solid curve).

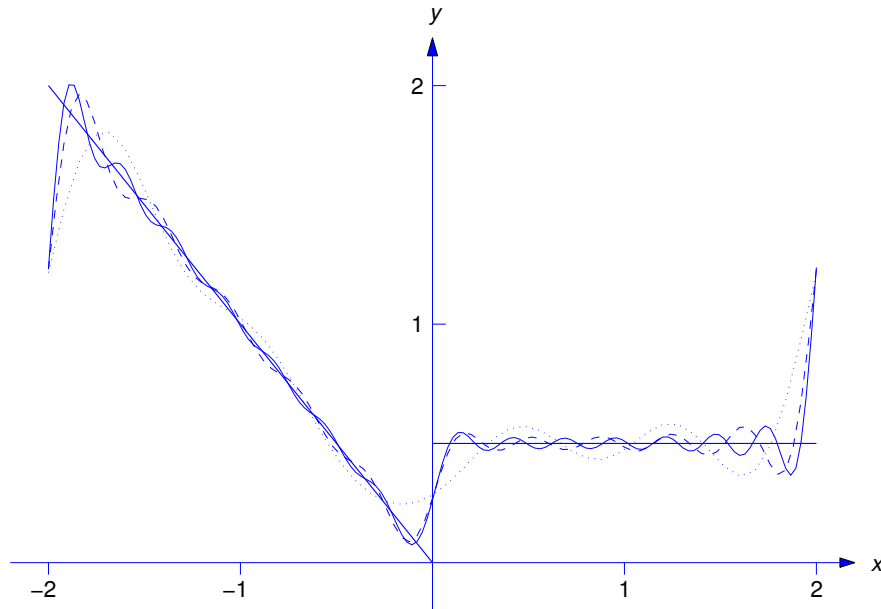

Figure 11.2.2

### Even and Odd Functions

Computing the Fourier coefficients of a function  $f$  can be tedious; however, the computation can often be simplified by exploiting symmetries in  $f$  or some of its terms. To focus on this, we recall some concepts that you studied in calculus. Let  $u$  and  $v$  be defined on  $[-L, L]$  and suppose that

$$u(-x) = u(x) \quad \text{and} \quad v(-x) = -v(x), \quad -L \leq x \leq L.$$

Then we say that  $u$  is an *even* function and  $v$  is an *odd function*. Note that:

- The product of two even functions is even.
- The product of two odd functions is even.
- The product of an even function and an odd function is odd.

**Example 11.2.2** The functions  $u(x) = \cos \omega x$  and  $u(x) = x^2$  are even, while  $v(x) = \sin \omega x$  and  $v(x) = x^3$  are odd. The function  $w(x) = e^x$  is neither even nor odd.

You learned parts (a) and (b) of the next theorem in calculus, and the other parts follow from them (Exercise 1).

**Theorem 11.2.5** Suppose  $u$  is even and  $v$  is odd on  $[-L, L]$ . Then:

$$\begin{aligned} \text{(a)} \quad & \int_{-L}^L u(x) dx = 2 \int_0^L u(x) dx, & \text{(b)} \quad & \int_{-L}^L v(x) dx = 0, \\ \text{(c)} \quad & \int_{-L}^L u(x) \cos \frac{n\pi x}{L} dx = 2 \int_0^L u(x) \cos \frac{n\pi x}{L} dx, \\ \text{(d)} \quad & \int_{-L}^L v(x) \sin \frac{n\pi x}{L} dx = 2 \int_0^L v(x) \sin \frac{n\pi x}{L} dx, \\ \text{(e)} \quad & \int_{-L}^L u(x) \sin \frac{n\pi x}{L} dx = 0 \quad \text{and} \quad \text{(f)} \quad & \int_{-L}^L v(x) \cos \frac{n\pi x}{L} dx = 0. \end{aligned}$$

**Example 11.2.3** Find the Fourier series of  $f(x) = x^2 - x$  on  $[-2, 2]$ , and determine its sum for  $-2 \leq x \leq 2$ .

**Solution** Since  $L = 2$ ,

$$F(x) = a_0 + \sum_{n=1}^{\infty} \left( a_n \cos \frac{n\pi x}{2} + b_n \sin \frac{n\pi x}{2} \right)$$

where

$$a_0 = \frac{1}{4} \int_{-2}^2 (x^2 - x) dx, \tag{11.2.9}$$

$$a_n = \frac{1}{2} \int_{-2}^2 (x^2 - x) \cos \frac{n\pi x}{2} dx, \quad n = 1, 2, 3, \dots, \tag{11.2.10}$$

and

$$b_n = \frac{1}{2} \int_{-2}^2 (x^2 - x) \sin \frac{n\pi x}{2} dx, \quad n = 1, 2, 3, \dots \tag{11.2.11}$$

We simplify the evaluation of these integrals by using Theorem 11.2.5 with  $u(x) = x^2$  and  $v(x) = x$ ; thus, from (11.2.9),

$$a_0 = \frac{1}{2} \int_0^2 x^2 dx = \frac{x^3}{6} \Big|_0^2 = \frac{4}{3}.$$

From (11.2.10),

$$\begin{aligned} a_n &= \int_0^2 x^2 \cos \frac{n\pi x}{2} dx = \frac{2}{n\pi} \left[ x^2 \sin \frac{n\pi x}{2} \Big|_0^2 - 2 \int_0^2 x \sin \frac{n\pi x}{2} dx \right] \\ &= \frac{8}{n^2 \pi^2} \left[ x \cos \frac{n\pi x}{2} \Big|_0^2 - \int_0^2 \cos \frac{n\pi x}{2} dx \right] \\ &= \frac{8}{n^2 \pi^2} \left[ 2 \cos n\pi - \frac{2}{n\pi} \sin \frac{n\pi x}{2} \Big|_0^2 \right] = (-1)^n \frac{16}{n^2 \pi^2}. \end{aligned}$$

From (11.2.11),

$$\begin{aligned} b_n &= - \int_0^2 x \sin \frac{n\pi x}{2} dx = \frac{2}{n\pi} \left[ x \cos \frac{n\pi x}{2} \Big|_0^2 - \int_0^2 \cos \frac{n\pi x}{2} dx \right] \\ &= \frac{2}{n\pi} \left[ 2 \cos n\pi - \frac{2}{n\pi} \sin \frac{n\pi x}{2} \Big|_0^2 \right] = (-1)^n \frac{4}{n\pi}. \end{aligned}$$

Therefore

$$F(x) = \frac{4}{3} + \frac{16}{\pi^2} \sum_{n=1}^{\infty} \frac{(-1)^n}{n^2} \cos \frac{n\pi x}{2} + \frac{4}{\pi} \sum_{n=1}^{\infty} \frac{(-1)^n}{n} \sin \frac{n\pi x}{2}.$$

Theorem 11.2.4 implies that

$$F(x) = \begin{cases} 4, & x = -2, \\ x^2 - x, & -2 < x < 2, \\ 4, & x = 2. \end{cases}$$

Figure 11.2.3 shows how the partial sum

$$F_m(x) = \frac{4}{3} + \frac{16}{\pi^2} \sum_{n=1}^m \frac{(-1)^n}{n^2} \cos \frac{n\pi x}{2} + \frac{4}{\pi} \sum_{n=1}^m \frac{(-1)^n}{n} \sin \frac{n\pi x}{2}$$

approximates  $f(x)$  for  $m = 5$  (dotted curve),  $m = 10$  (dashed curve), and  $m = 15$  (solid curve). ■

Theorem 11.2.5 implies the next theorem follows.

**Theorem 11.2.6** Suppose  $f$  is integrable on  $[-L, L]$ .

(a) If  $f$  is even, the Fourier series of  $f$  on  $[-L, L]$  is

$$F(x) = a_0 + \sum_{n=1}^{\infty} a_n \cos \frac{n\pi x}{L},$$

where

$$a_0 = \frac{1}{L} \int_0^L f(x) dx \quad \text{and} \quad a_n = \frac{2}{L} \int_0^L f(x) \cos \frac{n\pi x}{L} dx, \quad n \geq 1.$$



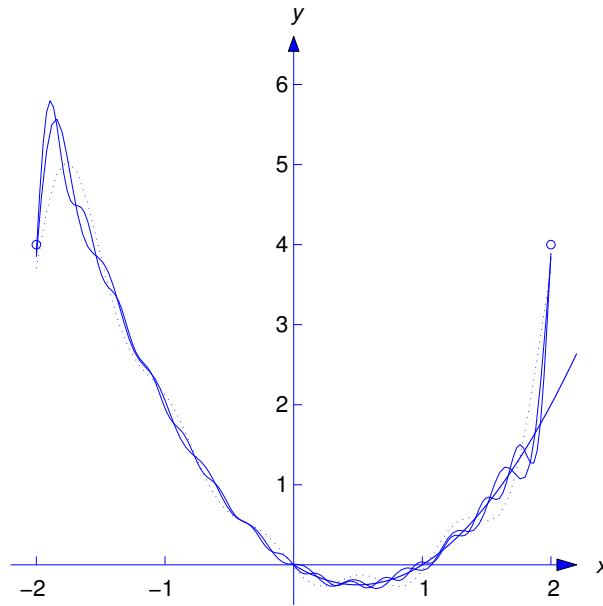

Figure 11.2.3 Approximation of  $f(x) = x^2 - x$  by partial sums of its Fourier series on  $[-2, 2]$

(b) If  $f$  is odd, the Fourier series of  $f$  on  $[-L, L]$  is

$$F(x) = \sum_{n=1}^{\infty} b_n \sin \frac{n\pi x}{L},$$

where

$$b_n = \frac{2}{L} \int_0^L f(x) \sin \frac{n\pi x}{L} dx.$$

**Example 11.2.4** Find the Fourier series of  $f(x) = x$  on  $[-\pi, \pi]$ , and determine its sum for  $-\pi \leq x \leq \pi$ .

**Solution** Since  $f$  is odd and  $L = \pi$ ,

$$F(x) = \sum_{n=1}^{\infty} b_n \sin nx$$

where

$$\begin{aligned} b_n &= \frac{2}{\pi} \int_0^{\pi} x \sin nx \, dx = -\frac{2}{n\pi} \left[ x \cos nx \Big|_0^{\pi} - \int_0^{\pi} \cos nx \, dx \right] \\ &= -\frac{2}{n} \cos n\pi + \frac{2}{n^2\pi} \sin nx \Big|_0^{\pi} = (-1)^{n+1} \frac{2}{n}. \end{aligned}$$

Therefore

$$F(x) = -2 \sum_{n=1}^{\infty} \frac{(-1)^n}{n} \sin nx.$$

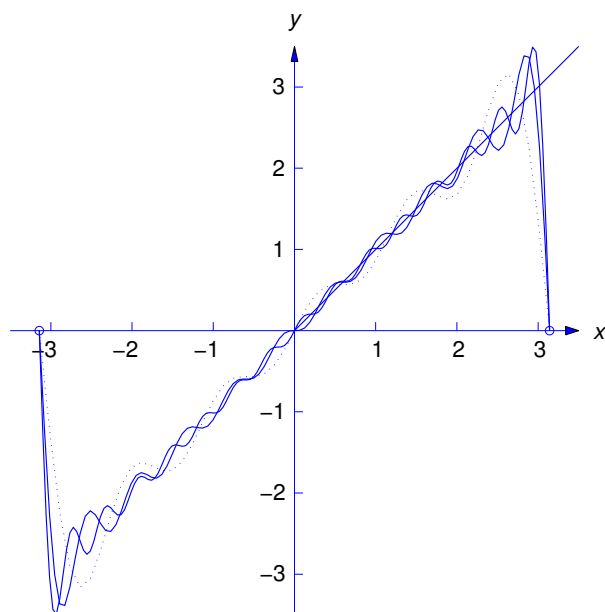

Figure 11.2.4 Approximation of  $f(x) = x$  by partial sums of its Fourier series on  $[-\pi, \pi]$

Theorem 11.2.4 implies that

$$F(x) = \begin{cases} 0, & x = -\pi, \\ x, & -\pi < x < \pi, \\ 0, & x = \pi. \end{cases}$$

Figure 11.2.4 shows how the partial sum

$$F_m(x) = -2 \sum_{n=1}^m \frac{(-1)^n}{n} \sin nx$$

approximates  $f(x)$  for  $m = 5$  (dotted curve),  $m = 10$  (dashed curve), and  $m = 15$  (solid curve).

**Example 11.2.5** Find the Fourier series of  $f(x) = |x|$  on  $[-\pi, \pi]$  and determine its sum for  $-\pi \leq x \leq \pi$ .

**Solution** Since  $f$  is even and  $L = \pi$ ,

$$F(x) = a_0 + \sum_{n=1}^{\infty} a_n \cos nx.$$

Since  $f(x) = x$  if  $x \geq 0$ ,

$$a_0 = \frac{1}{\pi} \int_0^{\pi} x \, dx = \frac{x^2}{2\pi} \Big|_0^{\pi} = \frac{\pi}{2}$$

and, if  $n \geq 1$ ,

$$\begin{aligned} a_n &= \frac{2}{\pi} \int_0^\pi x \cos nx \, dx = \frac{2}{n\pi} \left[ x \sin nx \Big|_0^\pi - \int_0^\pi \sin nx \, dx \right] \\ &= \frac{2}{n^2\pi} \cos nx \Big|_0^\pi = \frac{2}{n^2\pi} (\cos n\pi - 1) = \frac{2}{n^2\pi} [(-1)^n - 1]. \end{aligned}$$

Therefore

$$F(x) = \frac{\pi}{2} + \frac{2}{\pi} \sum_{n=0}^{\infty} \frac{(-1)^n - 1}{n^2} \cos nx. \quad (11.2.12)$$

However, since

$$(-1)^n - 1 = \begin{cases} 0 & \text{if } n = 2m, \\ -2 & \text{if } n = 2m + 1, \end{cases}$$

the terms in (11.2.12) for which  $n = 2m$  are all zeros. Therefore we only to include the terms for which  $n = 2m + 1$ ; that is, we can rewrite (11.2.12) as

$$F(x) = \frac{\pi}{2} - \frac{4}{\pi} \sum_{m=0}^{\infty} \frac{1}{(2m+1)^2} \cos(2m+1)x.$$

However, since the name of the index of summation doesn't matter, we prefer to replace  $m$  by  $n$ , and write

$$F(x) = \frac{\pi}{2} - \frac{4}{\pi} \sum_{n=0}^{\infty} \frac{1}{(2n+1)^2} \cos(2n+1)x.$$

Since  $|x|$  is continuous for all  $x$  and  $|- \pi| = |\pi|$ , Theorem 11.2.4 implies that  $F(x) = |x|$  for all  $x$  in  $[-\pi, \pi]$ .

**Example 11.2.6** Find the Fourier series of  $f(x) = x(x^2 - L^2)$  on  $[-L, L]$ , and determine its sum for  $-L \leq x \leq L$ .

**Solution** Since  $f$  is odd,

$$F(x) = \sum_{n=1}^{\infty} b_n \sin \frac{n\pi x}{L},$$

where

$$\begin{aligned} b_n &= \frac{2}{L} \int_0^L x(x^2 - L^2) \sin \frac{n\pi x}{L} \, dx \\ &= -\frac{2}{n\pi} \left[ x(x^2 - L^2) \cos \frac{n\pi x}{L} \Big|_0^L - \int_0^L (3x^2 - L^2) \cos \frac{n\pi x}{L} \, dx \right] \\ &= \frac{2L}{n^2\pi^2} \left[ (3x^2 - L^2) \sin \frac{n\pi x}{L} \Big|_0^L - 6 \int_0^L x \sin \frac{n\pi x}{L} \, dx \right] \\ &= \frac{12L^2}{n^3\pi^3} \left[ x \cos \frac{n\pi x}{L} \Big|_0^L - \int_0^L \cos \frac{n\pi x}{L} \, dx \right] = (-1)^n \frac{12L^3}{n^3\pi^3}. \end{aligned}$$

Therefore

$$F(x) = \frac{12L^3}{\pi^3} \sum_{n=1}^{\infty} \frac{(-1)^n}{n^3} \sin \frac{n\pi x}{L}.$$

Theorem 11.2.4 implies that  $F(x) = x(x^2 - L^2)$  for all  $x$  in  $[-L, L]$ .

**Example 11.2.7 (Gibbs Phenomenon)** The Fourier series of

$$f(x) = \begin{cases} 0, & -1 < x < -\frac{1}{2}, \\ 1, & -\frac{1}{2} < x < \frac{1}{2}, \\ 0, & \frac{1}{2} < x < 1 \end{cases}$$

on  $[-1, 1]$  is

$$F(x) = \frac{1}{2} + \frac{2}{\pi} \sum_{n=1}^{\infty} \frac{(-1)^{n-1}}{2n-1} \cos(2n-1)\pi x.$$

(Verify.) According to Theorem 11.2.4,

$$F(x) = \begin{cases} 0, & -1 \leq x < -\frac{1}{2}, \\ \frac{1}{2}, & x = -\frac{1}{2}, \\ 1, & -\frac{1}{2} < x < \frac{1}{2}, \\ \frac{1}{2}, & x = \frac{1}{2}, \\ 0, & \frac{1}{2} < x \leq 1; \end{cases}$$

thus,  $F$  (as well as  $f$ ) has unit jump discontinuities at  $x = \pm\frac{1}{2}$ . Figures 11.2.6-11.2.7 show the graphs of  $y = f(x)$  and

$$y = F_{2N-1}(x) = \frac{1}{2} + \frac{2}{\pi} \sum_{n=1}^N \frac{(-1)^{n-1}}{2n-1} \cos(2n-1)\pi x$$

for  $N = 10, 20,$  and  $30$ . You can see that although  $F_{2N-1}$  approximates  $F$  (and therefore  $f$ ) well on larger intervals as  $N$  increases, the maximum absolute values of the errors remain approximately equal to .09, but occur closer to the discontinuities  $x = \pm\frac{1}{2}$  as  $N$  increases.

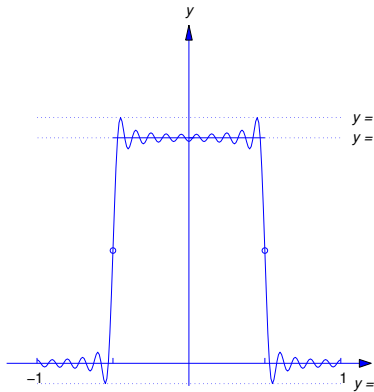

Figure 11.2.5 The Gibbs Phenomenon:  
Example 11.2.7,  $N = 10$

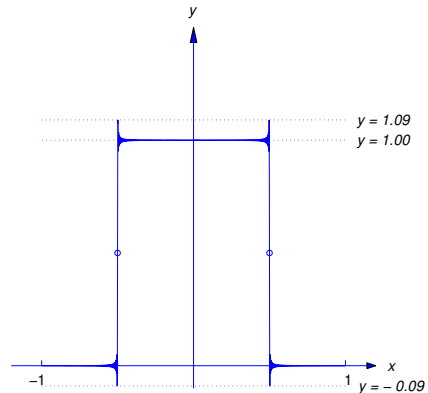
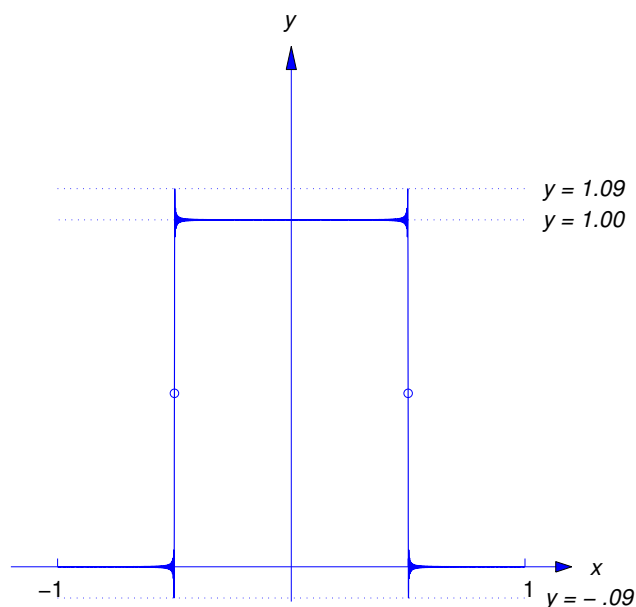

Figure 11.2.6 The Gibbs Phenomenon:  
Example 11.2.7,  $N = 20$

Figure 11.2.7 The Gibbs Phenomenon: Example 11.2.7,  $N = 30$ **USING TECHNOLOGY**

The computation of Fourier coefficients will be tedious in many of the exercises in this chapter and the next. To learn the technique, we recommend that you do some exercises in each section “by hand,” perhaps using the table of integrals at the front of the book. However, we encourage you to use your favorite symbolic computation software in the more difficult problems.

**11.2 Exercises**

1. Prove Theorem 11.1.5.

In Exercises 2-16 find the Fourier series of  $f$  on  $[-L, L]$  and determine its sum for  $-L \leq x \leq L$ . Where indicated by **C**, graph  $f$  and

$$F_m(x) = a_0 + \sum_{n=1}^m \left( a_n \cos \frac{n\pi x}{L} + b_n \sin \frac{n\pi x}{L} \right)$$

on the same axes for various values of  $m$ .

2. **C**  $L = 1$ ;  $f(x) = 2 - x$
3.  $L = \pi$ ;  $f(x) = 2x - 3x^2$
4.  $L = 1$ ;  $f(x) = 1 - 3x^2$
5.  $L = \pi$ ;  $f(x) = |\sin x|$

6.  $\boxed{\text{C}}$   $L = \pi$ ;  $f(x) = x \cos x$
7.  $L = \pi$ ;  $f(x) = |x| \cos x$
8.  $\boxed{\text{C}}$   $L = \pi$ ;  $f(x) = x \sin x$
9.  $L = \pi$ ;  $f(x) = |x| \sin x$
10.  $L = 1$ ;  $f(x) = \begin{cases} 0, & -1 < x < \frac{1}{2}, \\ \cos \pi x, & -\frac{1}{2} < x < \frac{1}{2}, \\ 0, & \frac{1}{2} < x < 1 \end{cases}$
11.  $L = 1$ ;  $f(x) = \begin{cases} 0, & -1 < x < \frac{1}{2}, \\ x \cos \pi x, & -\frac{1}{2} < x < \frac{1}{2}, \\ 0, & \frac{1}{2} < x < 1 \end{cases}$
12.  $L = 1$ ;  $f(x) = \begin{cases} 0, & -1 < x < \frac{1}{2}, \\ \sin \pi x, & -\frac{1}{2} < x < \frac{1}{2}, \\ 0, & \frac{1}{2} < x < 1 \end{cases}$
13.  $L = 1$ ;  $f(x) = \begin{cases} 0, & -1 < x < \frac{1}{2}, \\ |\sin \pi x|, & -\frac{1}{2} < x < \frac{1}{2}, \\ 0, & \frac{1}{2} < x < 1 \end{cases}$
14.  $L = 1$ ;  $f(x) = \begin{cases} 0, & -1 < x < \frac{1}{2}, \\ x \sin \pi x, & -\frac{1}{2} < x < \frac{1}{2}, \\ 0, & \frac{1}{2} < x < 1 \end{cases}$
15.  $\boxed{\text{C}}$   $L = 4$ ;  $f(x) = \begin{cases} 0, & -4 < x < 0, \\ x, & 0 < x < 4 \end{cases}$
16.  $\boxed{\text{C}}$   $L = 1$ ;  $f(x) = \begin{cases} x^2, & -1 < x < 0, \\ 1 - x^2, & 0 < x < 1 \end{cases}$
17.  $\boxed{\text{L}}$  Verify the Gibbs phenomenon for  $f(x) = \begin{cases} 2, & -2 < x < -1, \\ 1, & -1 < x < 1, \\ -1, & 1 < x < 2. \end{cases}$
18.  $\boxed{\text{L}}$  Verify the Gibbs phenomenon for  $f(x) = \begin{cases} 2, & -3 < x < -2, \\ 3, & -2 < x < 2, \\ 1, & 2 < x < 3. \end{cases}$
19. Deduce from Example 11.2.5 that

$$\sum_{n=0}^{\infty} \frac{1}{(2n+1)^2} = \frac{\pi^2}{8}.$$

20. (a) Find the Fourier series of  $f(x) = e^x$  on  $[-\pi, \pi]$ .
- (b) Deduce from (a) that

$$\sum_{n=0}^{\infty} \frac{1}{n^2 + 1} = \frac{\pi \coth \pi - 1}{2}.$$

21. Find the Fourier series of  $f(x) = (x - \pi) \cos x$  on  $[-\pi, \pi]$ .
22. Find the Fourier series of  $f(x) = (x - \pi) \sin x$  on  $[-\pi, \pi]$ .
23. Find the Fourier series of  $f(x) = \sin kx$  ( $k \neq \text{integer}$ ) on  $[-\pi, \pi]$ .
24. Find the Fourier series of  $f(x) = \cos kx$  ( $k \neq \text{integer}$ ) on  $[-\pi, \pi]$ .
25. (a) Suppose  $g'$  is continuous on  $[a, b]$  and  $\omega \neq 0$ . Use integration by parts to show that there's a constant  $M$  such that

$$\left| \int_a^b g(x) \cos \omega x \, dx \right| \leq \frac{M}{\omega} \quad \text{and} \quad \left| \int_a^b g(x) \sin \omega x \, dx \right| \leq \frac{M}{\omega}, \quad \omega > 0.$$

- (b) Show that the conclusion of (a) also holds if  $g$  is piecewise smooth on  $[a, b]$ . (This is a special case of *Riemann's Lemma*.)
- (c) We say that a sequence  $\{\alpha_n\}_{n=1}^{\infty}$  is of order  $n^{-k}$  and write  $\alpha_n = O(1/n^k)$  if there's a constant  $M$  such that

$$|\alpha_n| < \frac{M}{n^k}, \quad n = 1, 2, 3, \dots$$

Let  $\{a_n\}_{n=1}^{\infty}$  and  $\{b_n\}_{n=1}^{\infty}$  be the Fourier coefficients of a piecewise smooth function. Conclude from (b) that  $a_n = O(1/n)$  and  $b_n = O(1/n)$ .

26. (a) Suppose  $f(-L) = f(L)$ ,  $f'(-L) = f'(L)$ ,  $f'$  is continuous, and  $f''$  is piecewise continuous on  $[-L, L]$ . Use Theorem 11.2.4 and integration by parts to show that

$$f(x) = a_0 + \sum_{n=1}^{\infty} \left( a_n \cos \frac{n\pi x}{L} + b_n \sin \frac{n\pi x}{L} \right), \quad -L \leq x \leq L,$$

with

$$a_0 = \frac{1}{2L} \int_{-L}^L f(x) \, dx,$$

$$a_n = -\frac{L}{n^2\pi^2} \int_{-L}^L f''(x) \cos \frac{n\pi x}{L} \, dx, \quad \text{and} \quad b_n = -\frac{L}{n^2\pi^2} \int_{-L}^L f''(x) \sin \frac{n\pi x}{L} \, dx, \quad n \geq 1.$$

- (b) Show that if, in addition to the assumptions in (a),  $f''$  is continuous and  $f'''$  is piecewise continuous on  $[-L, L]$ , then

$$a_n = \frac{L^2}{n^3\pi^3} \int_{-L}^L f'''(x) \sin \frac{n\pi x}{L} \, dx.$$

27. Show that if  $f$  is integrable on  $[-L, L]$  and

$$f(x+L) = f(x), \quad -L < x < 0$$

(Figure 11.2.8), then the Fourier series of  $f$  on  $[-L, L]$  has the form

$$A_0 + \sum_{n=1}^{\infty} \left( A_n \cos \frac{2n\pi x}{L} + B_n \sin \frac{2n\pi x}{L} \right)$$

where

$$A_0 = \frac{1}{L} \int_0^L f(x) \, dx,$$

and

$$A_n = \frac{2}{L} \int_0^L f(x) \cos \frac{2n\pi x}{L} dx, \quad B_n = \frac{2}{L} \int_0^L f(x) \sin \frac{2n\pi x}{L} dx, \quad n = 1, 2, 3, \dots$$

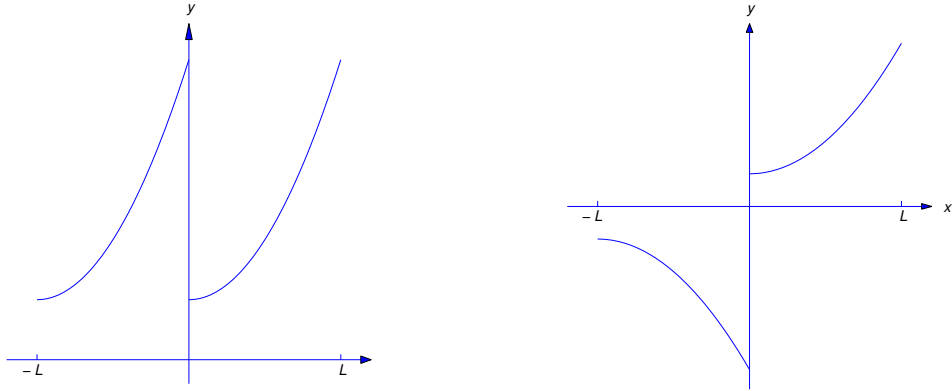

Figure 11.2.8  $y = f(x)$ , where  $f(x + L) = f(x)$ ,  $-L < x < 0$       Figure 11.2.9  $y = f(x)$ , where  $f(x + L) = -f(x)$ ,  $-L < x < 0$

28. Show that if  $f$  is integrable on  $[-L, L]$  and

$$f(x + L) = -f(x), \quad -L < x < 0$$

(Figure 11.2.9), then the Fourier series of  $f$  on  $[-L, L]$  has the form

$$\sum_{n=1}^{\infty} \left( A_n \cos \frac{(2n-1)\pi x}{L} + B_n \sin \frac{(2n-1)\pi x}{L} \right),$$

where

$$A_n = \frac{2}{L} \int_0^L f(x) \cos \frac{(2n-1)\pi x}{L} dx \quad \text{and} \quad B_n = \frac{2}{L} \int_0^L f(x) \sin \frac{(2n-1)\pi x}{L} dx, \quad n = 1, 2, 3, \dots$$

29. Suppose  $\phi_1, \phi_2, \dots, \phi_m$  are orthogonal on  $[a, b]$  and

$$\int_a^b \phi_n^2(x) dx \neq 0, \quad n = 1, 2, \dots, m.$$

If  $a_1, a_2, \dots, a_m$  are arbitrary real numbers, define

$$P_m = a_1\phi_1 + a_2\phi_2 + \dots + a_m\phi_m.$$

Let

$$F_m = c_1\phi_1 + c_2\phi_2 + \dots + c_m\phi_m,$$

where

$$c_n = \frac{\int_a^b f(x)\phi_n(x) dx}{\int_a^b \phi_n^2(x) dx};$$

that is,  $c_1, c_2, \dots, c_m$  are Fourier coefficients of  $f$ .



(a) Show that

$$\int_a^b (f(x) - F_m(x))\phi_n(x) dx = 0, \quad n = 1, 2, \dots, m.$$

(b) Show that

$$\int_a^b (f(x) - F_m(x))^2 dx \leq \int_a^b (f(x) - P_m(x))^2 dx,$$

with equality if and only if  $a_n = c_n$ ,  $n = 1, 2, \dots, m$ .

(c) Show that

$$\int_a^b (f(x) - F_m(x))^2 dx = \int_a^b f^2(x) dx - \sum_{n=1}^m c_n^2 \int_a^b \phi_n^2 dx.$$

(d) Conclude from (c) that

$$\sum_{n=1}^m c_n^2 \int_a^b \phi_n^2(x) dx \leq \int_a^b f^2(x) dx.$$

30. If  $A_0, A_1, \dots, A_m$  and  $B_1, B_2, \dots, B_m$  are arbitrary constants we say that

$$P_m(x) = A_0 + \sum_{n=1}^m \left( A_n \cos \frac{n\pi x}{L} + B_n \sin \frac{n\pi x}{L} \right)$$

is a *trigonometric polynomial of degree  $\leq m$* .

Now let

$$a_0 + \sum_{n=1}^{\infty} \left( a_n \cos \frac{n\pi x}{L} + b_n \sin \frac{n\pi x}{L} \right)$$

be the Fourier series of an integrable function  $f$  on  $[-L, L]$ , and let

$$F_m(x) = a_0 + \sum_{n=1}^m \left( a_n \cos \frac{n\pi x}{L} + b_n \sin \frac{n\pi x}{L} \right).$$

(a) Conclude from Exercise 29(b) that

$$\int_{-L}^L (f(x) - F_m(x))^2 dx \leq \int_{-L}^L (f(x) - P_m(x))^2 dx,$$

with equality if and only if  $A_n = a_n$ ,  $n = 0, 1, \dots, m$ , and  $B_n = b_n$ ,  $n = 1, 2, \dots, m$ .

(b) Conclude from Exercise 29(d) that

$$2a_0^2 + \sum_{n=1}^m (a_n^2 + b_n^2) \leq \frac{1}{L} \int_{-L}^L f^2(x) dx$$

for every  $m \geq 0$ .

(c) Conclude from (b) that  $\lim_{n \rightarrow \infty} a_n = \lim_{n \rightarrow \infty} b_n = 0$ .

## 11.3 FOURIER EXPANSIONS II

In this section we discuss Fourier expansions in terms of the eigenfunctions of Problems 1-4 for Section 11.1.

### Fourier Cosine Series

From Exercise 11.1.20, the eigenfunctions

$$1, \cos \frac{\pi x}{L}, \cos \frac{2\pi x}{L}, \dots, \cos \frac{n\pi x}{L}, \dots$$

of the boundary value problem

$$y'' + \lambda y = 0, \quad y'(0) = 0, \quad y'(L) = 0 \quad (11.3.1)$$

(Problem 2) are orthogonal on  $[0, L]$ . If  $f$  is integrable on  $[0, L]$  then the Fourier expansion of  $f$  in terms of these functions is called the *Fourier cosine series of  $f$  on  $[0, L]$* . This series is

$$a_0 + \sum_{n=1}^{\infty} a_n \cos \frac{n\pi x}{L},$$

where

$$a_0 = \frac{\int_0^L f(x) dx}{\int_0^L dx} = \frac{1}{L} \int_0^L f(x) dx$$

and

$$a_n = \frac{\int_0^L f(x) \cos \frac{n\pi x}{L} dx}{\int_0^L \cos^2 \frac{n\pi x}{L} dx} = \frac{2}{L} \int_0^L f(x) \cos \frac{n\pi x}{L} dx, \quad n = 1, 2, 3, \dots$$

Comparing this definition with Theorem 6(a) shows that the Fourier cosine series of  $f$  on  $[0, L]$  is the Fourier series of the function

$$f_1(x) = \begin{cases} f(-x), & -L < x < 0, \\ f(x), & 0 \leq x \leq L, \end{cases}$$

obtained by extending  $f$  over  $[-L, L]$  as an even function (Figure 11.3.1).

Applying Theorem 11.2.4 to  $f_1$  yields the next theorem.

**Theorem 11.3.1** *If  $f$  is piecewise smooth on  $[0, L]$ , then the Fourier cosine series*

$$C(x) = a_0 + \sum_{n=1}^{\infty} a_n \cos \frac{n\pi x}{L}$$

*of  $f$  on  $[0, L]$ , with*

$$a_0 = \frac{1}{L} \int_0^L f(x) dx \quad \text{and} \quad a_n = \frac{2}{L} \int_0^L f(x) \cos \frac{n\pi x}{L} dx, \quad n = 1, 2, 3, \dots,$$

*converges for all  $x$  in  $[0, L]$ ; moreover,*

$$C(x) = \begin{cases} f(0+) & \text{if } x = 0 \\ f(x) & \text{if } 0 < x < L \text{ and } f \text{ is continuous at } x \\ \frac{f(x-) + f(x+)}{2} & \text{if } 0 < x < L \text{ and } f \text{ is discontinuous at } x \\ f(L-) & \text{if } x = L. \end{cases}$$

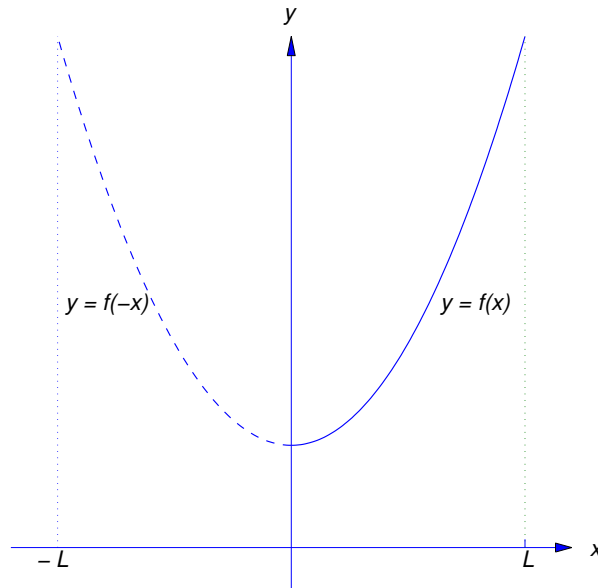

Figure 11.3.1

**Example 11.3.1** Find the Fourier cosine series of  $f(x) = x$  on  $[0, L]$ .

**Solution** The coefficients are

$$a_0 = \frac{1}{L} \int_0^L x \, dx = \frac{1}{L} \left. \frac{x^2}{2} \right|_0^L = \frac{L}{2}$$

and, if  $n \geq 1$

$$\begin{aligned} a_n &= \frac{2}{L} \int_0^L x \cos \frac{n\pi x}{L} \, dx = \frac{2}{n\pi} \left[ x \sin \frac{n\pi x}{L} \Big|_0^L - \int_0^L \sin \frac{n\pi x}{L} \, dx \right] \\ &= -\frac{2}{n\pi} \int_0^L \sin \frac{n\pi x}{L} \, dx = \frac{2L}{n^2\pi^2} \cos \frac{n\pi x}{L} \Big|_0^L = \frac{2L}{n^2\pi^2} [(-1)^n - 1] \\ &= \begin{cases} -\frac{4L}{(2m-1)^2\pi^2} & \text{if } n = 2m-1, \\ 0 & \text{if } n = 2m. \end{cases} \end{aligned}$$

Therefore

$$C(x) = \frac{L}{2} - \frac{4L}{\pi^2} \sum_{n=1}^{\infty} \frac{1}{(2n-1)^2} \cos \frac{(2n-1)\pi x}{L}.$$

Theorem 11.3.1 implies that

$$C(x) = x, \quad 0 \leq x \leq L.$$

**Fourier Sine Series**

From Exercise 11.1.19, the eigenfunctions

$$\sin \frac{\pi x}{L}, \sin \frac{2\pi x}{L}, \dots, \sin \frac{n\pi x}{L}, \dots$$

of the boundary value problem

$$y'' + \lambda y = 0, \quad y(0) = 0, \quad y(L) = 0$$

(Problem 1) are orthogonal on  $[0, L]$ . If  $f$  is integrable on  $[0, L]$  then the Fourier expansion of  $f$  in terms of these functions is called the *Fourier sine series of  $f$  on  $[0, L]$* . This series is

$$\sum_{n=1}^{\infty} b_n \sin \frac{n\pi x}{L},$$

where

$$b_n = \frac{\int_0^L f(x) \sin \frac{n\pi x}{L} dx}{\int_0^L \sin^2 \frac{n\pi x}{L} dx} = \frac{2}{L} \int_0^L f(x) \sin \frac{n\pi x}{L} dx, \quad n = 1, 2, 3, \dots$$

Comparing this definition with Theorem 6(b) shows that the Fourier sine series of  $f$  on  $[0, L]$  is the Fourier series of the function

$$f_2(x) = \begin{cases} -f(-x), & -L < x < 0, \\ f(x), & 0 \leq x \leq L, \end{cases}$$

obtained by extending  $f$  over  $[-L, L]$  as an odd function (Figure 11.3.2).

Applying Theorem 11.2.4 to  $f_2$  yields the next theorem.

**Theorem 11.3.2** *If  $f$  is piecewise smooth on  $[0, L]$ , then the Fourier sine series*

$$S(x) = \sum_{n=1}^{\infty} b_n \sin \frac{n\pi x}{L}$$

*of  $f$  on  $[0, L]$ , with*

$$b_n = \frac{2}{L} \int_0^L f(x) \sin \frac{n\pi x}{L} dx,$$

*converges for all  $x$  in  $[0, L]$ ; moreover,*

$$S(x) = \begin{cases} 0 & \text{if } x = 0 \\ f(x) & \text{if } 0 < x < L \text{ and } f \text{ is continuous at } x \\ \frac{f(x-) + f(x+)}{2} & \text{if } 0 < x < L \text{ and } f \text{ is discontinuous at } x \\ 0 & \text{if } x = L. \end{cases}$$

**Example 11.3.2** Find the Fourier sine series of  $f(x) = x$  on  $[0, L]$ .

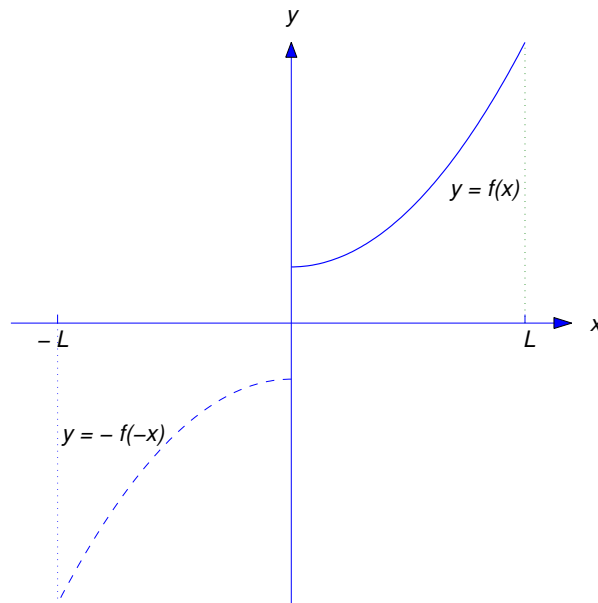

Figure 11.3.2

**Solution** The coefficients are

$$\begin{aligned} b_n &= \frac{2}{L} \int_0^L x \sin \frac{n\pi x}{L} dx = -\frac{2}{n\pi} \left[ x \cos \frac{n\pi x}{L} \Big|_0^L - \int_0^L \cos \frac{n\pi x}{L} dx \right] \\ &= (-1)^{n+1} \frac{2L}{n\pi} + \frac{2L}{n^2\pi^2} \sin \frac{n\pi x}{L} \Big|_0^L = (-1)^{n+1} \frac{2L}{n\pi}. \end{aligned}$$

Therefore

$$S(x) = -\frac{2L}{\pi} \sum_{n=1}^{\infty} \frac{(-1)^n}{n} \sin \frac{n\pi x}{L}.$$

Theorem 11.3.2 implies that

$$S(x) = \begin{cases} x, & 0 \leq x < L, \\ 0, & x = L. \end{cases}$$

### Mixed Fourier Cosine Series

From Exercise 11.1.22, the eigenfunctions

$$\cos \frac{\pi x}{2L}, \cos \frac{3\pi x}{2L}, \dots, \cos \frac{(2n-1)\pi x}{2L}, \dots$$

of the boundary value problem

$$y'' + \lambda y = 0, \quad y'(0) = 0, \quad y(L) = 0 \tag{11.3.2}$$

(Problem 4) are orthogonal on  $[0, L]$ . If  $f$  is integrable on  $[0, L]$  then the Fourier expansion of  $f$  in terms of these functions is

$$\sum_{n=1}^{\infty} c_n \cos \frac{(2n-1)\pi x}{2L},$$

where

$$c_n = \frac{\int_0^L f(x) \cos \frac{(2n-1)\pi x}{2L} dx}{\int_0^L \cos^2 \frac{(2n-1)\pi x}{L} dx} = \frac{2}{L} \int_0^L f(x) \cos \frac{(2n-1)\pi x}{2L} dx.$$

We'll call this expansion the *mixed Fourier cosine series* of  $f$  on  $[0, L]$ , because the boundary conditions of (11.3.2) are “mixed” in that they require  $y$  to be zero at one boundary point and  $y'$  to be zero at the other. By contrast, the “ordinary” Fourier cosine series is associated with (11.3.1), where the boundary conditions require that  $y'$  be zero at both endpoints.

It can be shown (Exercise 57) that the mixed Fourier cosine series of  $f$  on  $[0, L]$  is simply the restriction to  $[0, L]$  of the Fourier cosine series of

$$f_3(x) = \begin{cases} f(x), & 0 \leq x \leq L, \\ -f(2L-x), & L < x \leq 2L \end{cases}$$

on  $[0, 2L]$  (Figure 11.3.3).

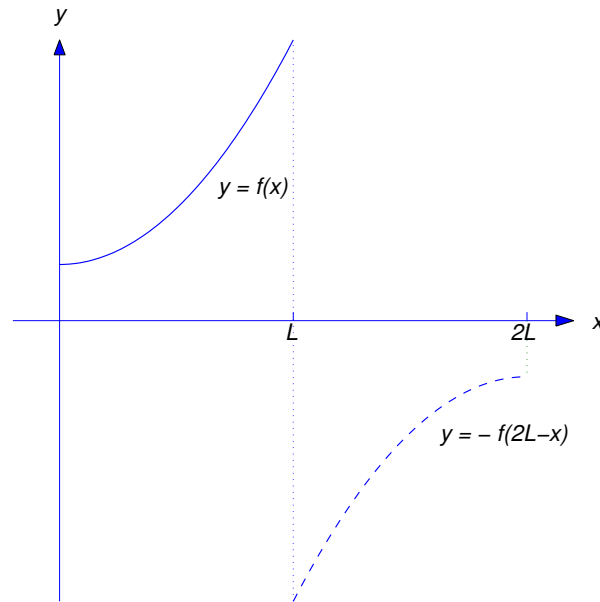

Figure 11.3.3

Applying Theorem 11.3.1 with  $f$  replaced by  $f_3$  and  $L$  replaced by  $2L$  yields the next theorem.

**Theorem 11.3.3** *If  $f$  is piecewise smooth on  $[0, L]$ , then the mixed Fourier cosine series*

$$C_M(x) = \sum_{n=1}^{\infty} c_n \cos \frac{(2n-1)\pi x}{2L}$$

*of  $f$  on  $[0, L]$ , with*

$$c_n = \frac{2}{L} \int_0^L f(x) \cos \frac{(2n-1)\pi x}{2L} dx,$$

*converges for all  $x$  in  $[0, L]$ ; moreover,*

$$C_M(x) = \begin{cases} f(0+) & \text{if } x = 0 \\ f(x) & \text{if } 0 < x < L \text{ and } f \text{ is continuous at } x \\ \frac{f(x-) + f(x+)}{2} & \text{if } 0 < x < L \text{ and } f \text{ is discontinuous at } x \\ 0 & \text{if } x = L. \end{cases}$$

**Example 11.3.3** Find the mixed Fourier cosine series of  $f(x) = x - L$  on  $[0, L]$ .

**Solution** The coefficients are

$$\begin{aligned} c_n &= \frac{2}{L} \int_0^L (x - L) \cos \frac{(2n-1)\pi x}{2L} dx \\ &= \frac{4}{(2n-1)\pi} \left[ (x - L) \sin \frac{(2n-1)\pi x}{2L} \Big|_0^L - \int_0^L \sin \frac{(2n-1)\pi x}{2L} dx \right] \\ &= \frac{8L}{(2n-1)^2\pi^2} \cos \frac{(2n-1)\pi x}{2L} \Big|_0^L = -\frac{8L}{(2n-1)^2\pi^2}. \end{aligned}$$

Therefore

$$C_M(x) = -\frac{8L}{\pi^2} \sum_{n=1}^{\infty} \frac{1}{(2n-1)^2} \cos \frac{(2n-1)\pi x}{2L}.$$

Theorem 11.3.3 implies that

$$C_M(x) = x - L, \quad 0 \leq x \leq L.$$

### Mixed Fourier Sine Series

From Exercise 11.1.21, the eigenfunctions

$$\sin \frac{\pi x}{2L}, \sin \frac{3\pi x}{2L}, \dots, \sin \frac{(2n-1)\pi x}{2L}, \dots$$

of the boundary value problem

$$y'' + \lambda y = 0, \quad y(0) = 0, \quad y'(L) = 0$$

(Problem 3) are orthogonal on  $[0, L]$ . If  $f$  is integrable on  $[0, L]$ , then the Fourier expansion of  $f$  in terms of these functions is

$$\sum_{n=1}^{\infty} d_n \sin \frac{(2n-1)\pi x}{2L},$$

where

$$d_n = \frac{\int_0^L f(x) \sin \frac{(2n-1)\pi x}{2L} dx}{\int_0^L \sin^2 \frac{(2n-1)\pi x}{2L} dx} = \frac{2}{L} \int_0^L f(x) \sin \frac{(2n-1)\pi x}{2L} dx.$$

We'll call this expansion the *mixed Fourier sine series* of  $f$  on  $[0, L]$ .

It can be shown (Exercise 58) that the mixed Fourier sine series of  $f$  on  $[0, L]$  is simply the restriction to  $[0, L]$  of the Fourier sine series of

$$f_4(x) = \begin{cases} f(x), & 0 \leq x \leq L, \\ f(2L-x), & L < x \leq 2L, \end{cases}$$

on  $[0, 2L]$  (Figure 11.3.4).

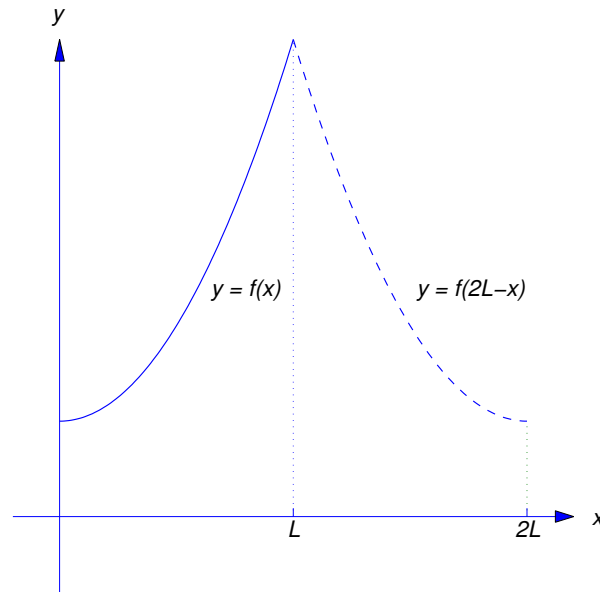

Figure 11.3.4

Applying Theorem 11.3.2 with  $f$  replaced by  $f_4$  and  $L$  replaced by  $2L$  yields the next theorem.

**Theorem 11.3.4** *If  $f$  is piecewise smooth on  $[0, L]$ , then the mixed Fourier sine series*

$$S_M(x) = \sum_{n=1}^{\infty} d_n \sin \frac{(2n-1)\pi x}{2L}$$

*of  $f$  on  $[0, L]$ , with*

$$d_n = \frac{2}{L} \int_0^L f(x) \sin \frac{(2n-1)\pi x}{2L} dx,$$



converges for all  $x$  in  $[0, L]$ ; moreover,

$$S_M(x) = \begin{cases} 0 & \text{if } x = 0 \\ f(x) & \text{if } 0 < x < L \text{ and } f \text{ is continuous at } x \\ \frac{f(x-) + f(x+)}{2} & \text{if } 0 < x < L \text{ and } f \text{ is discontinuous at } x \\ f(L-) & \text{if } x = L. \end{cases}$$

**Example 11.3.4** Find the mixed Fourier sine series of  $f(x) = x$  on  $[0, L]$ .

**Solution** The coefficients are

$$\begin{aligned} d_n &= \frac{2}{L} \int_0^L x \sin \frac{(2n-1)\pi x}{2L} dx \\ &= -\frac{4}{(2n-1)\pi} \left[ x \cos \frac{(2n-1)\pi x}{2L} \Big|_0^L - \int_0^L \cos \frac{(2n-1)\pi x}{2L} dx \right] \\ &= \frac{4}{(2n-1)\pi} \int_0^L \cos \frac{(2n-1)\pi x}{2L} dx \\ &= \frac{8L}{(2n-1)^2\pi^2} \sin \frac{(2n-1)\pi x}{2L} \Big|_0^L = (-1)^{n+1} \frac{8L}{(2n-1)^2\pi^2}. \end{aligned}$$

Therefore

$$S_M(x) = -\frac{8L}{\pi^2} \sum_{n=1}^{\infty} \frac{(-1)^n}{(2n-1)^2} \sin \frac{(2n-1)\pi x}{2L}.$$

Theorem 11.3.4 implies that

$$S_M(x) = x, \quad 0 \leq x \leq L.$$

### A Useful Observation

In applications involving expansions in terms of the eigenfunctions of Problems 1-4, the functions being expanded are often polynomials that satisfy the boundary conditions of the problem under consideration. In this case the next theorem presents an efficient way to obtain the coefficients in the expansion.

### Theorem 11.3.5

(a) If  $f'(0) = f'(L) = 0$ ,  $f''$  is continuous, and  $f'''$  is piecewise continuous on  $[0, L]$ , then

$$f(x) = a_0 + \sum_{n=1}^{\infty} a_n \cos \frac{n\pi x}{L}, \quad 0 \leq x \leq L, \quad (11.3.3)$$

with

$$a_0 = \frac{1}{L} \int_0^L f(x) dx \quad \text{and} \quad a_n = \frac{2L^2}{n^3\pi^3} \int_0^L f'''(x) \sin \frac{n\pi x}{L} dx, \quad n \geq 1. \quad (11.3.4)$$

Now suppose  $f'$  is continuous and  $f''$  is piecewise continuous on  $[0, L]$ .

(b) If  $f(0) = f(L) = 0$ , then

$$f(x) = \sum_{n=1}^{\infty} b_n \sin \frac{n\pi x}{L}, \quad 0 \leq x \leq L,$$

with

$$b_n = -\frac{2L}{n^2\pi^2} \int_0^L f''(x) \sin \frac{n\pi x}{L} dx. \quad (11.3.5)$$

(c) If  $f'(0) = f(L) = 0$ , then

$$f(x) = \sum_{n=1}^{\infty} c_n \cos \frac{(2n-1)\pi x}{2L}, \quad 0 \leq x \leq L,$$

with

$$c_n = -\frac{8L}{(2n-1)^2\pi^2} \int_0^L f''(x) \cos \frac{(2n-1)\pi x}{2L} dx. \quad (11.3.6)$$

(d) If  $f(0) = f'(L) = 0$ , then

$$f(x) = \sum_{n=1}^{\infty} d_n \sin \frac{(2n-1)\pi x}{2L}, \quad 0 \leq x \leq L,$$

with

$$d_n = -\frac{8L}{(2n-1)^2\pi^2} \int_0^L f''(x) \sin \frac{(2n-1)\pi x}{2L} dx. \quad (11.3.7)$$

**Proof** We'll prove (a) and leave the rest to you (Exercises 35, 42, and 50). Since  $f$  is continuous on  $[0, L]$ , Theorem 11.3.1 implies (11.3.3) with  $a_0, a_1, a_2, \dots$  as defined in Theorem 11.3.1. We already know that  $a_0$  is as in (11.3.4). If  $n \geq 1$ , integrating twice by parts yields

$$\begin{aligned} a_n &= \frac{2}{L} \int_0^L f(x) \cos \frac{n\pi x}{L} dx \\ &= \frac{2}{n\pi} \left[ f(x) \sin \frac{n\pi x}{L} \Big|_0^L - \int_0^L f'(x) \sin \frac{n\pi x}{L} dx \right] \\ &= -\frac{2}{n\pi} \int_0^L f'(x) \sin \frac{n\pi x}{L} dx \quad (\text{since } \sin 0 = \sin n\pi = 0) \\ &= \frac{2L}{n^2\pi^2} \left[ f'(x) \cos \frac{n\pi x}{L} \Big|_0^L - \int_0^L f''(x) \cos \frac{n\pi x}{L} dx \right] \\ &= -\frac{2L}{n^2\pi^2} \int_0^L f''(x) \cos \frac{n\pi x}{L} dx \quad (\text{since } f'(0) = f'(L) = 0) \\ &= -\frac{2L^2}{n^3\pi^3} \left[ f''(x) \sin \frac{n\pi x}{L} \Big|_0^L - \int_0^L f'''(x) \sin \frac{n\pi x}{L} dx \right] \\ &= \frac{2L^2}{n^3\pi^3} \int_0^L f'''(x) \sin \frac{n\pi x}{L} dx \quad (\text{since } \sin 0 = \sin n\pi = 0). \end{aligned}$$

(By an argument similar to one used in the proof of Theorem 8.3.1, the last integration by parts is legitimate in the case where  $f'''$  is undefined at finitely many points in  $[0, L]$ , so long as it's piecewise continuous on  $[0, L]$ .) This completes the proof.

**Example 11.3.5** Find the Fourier cosine expansion of  $f(x) = x^2(3L - 2x)$  on  $[0, L]$ .

**Solution** Here

$$a_0 = \frac{1}{L} \int_0^L (3Lx^2 - 2x^3) dx = \frac{1}{L} \left( Lx^3 - \frac{x^4}{2} \right) \Big|_0^L = \frac{L^3}{2}$$

and

$$a_n = \frac{2}{L} \int_0^L (3Lx^2 - 2x^3) \cos \frac{n\pi x}{L} dx, \quad n \geq 1.$$

Evaluating this integral directly is laborious. However, since  $f'(x) = 6Lx - 6x^2$ , we see that  $f'(0) = f'(L) = 0$ . Since  $f'''(x) = -12$ , we see from (11.3.4) that if  $n \geq 1$  then

$$\begin{aligned} a_n &= -\frac{24L^2}{n^3\pi^3} \int_0^L \sin \frac{n\pi x}{L} dx = \frac{24L^3}{n^4\pi^4} \cos \frac{n\pi x}{L} \Big|_0^L = \frac{24L^3}{n^4\pi^4} [(-1)^n - 1] \\ &= \begin{cases} -\frac{48L^3}{(2m-1)^4\pi^4} & \text{if } n = 2m-1, \\ 0 & \text{if } n = 2m. \end{cases} \end{aligned}$$

Therefore

$$C(x) = \frac{L^3}{2} - \frac{48L^3}{\pi^4} \sum_{n=1}^{\infty} \frac{1}{(2n-1)^4} \cos \frac{(2n-1)\pi x}{L}.$$

**Example 11.3.6** Find the Fourier sine expansion of  $f(x) = x(x^2 - 3Lx + 2L^2)$  on  $[0, L]$ .

**Solution** Since  $f(0) = f(L) = 0$  and  $f''(x) = 6(x - L)$ , we see from (11.3.5) that

$$\begin{aligned} b_n &= -\frac{12L}{n^2\pi^2} \int_0^L (x - L) \sin \frac{n\pi x}{L} dx \\ &= \frac{12L^2}{n^3\pi^3} \left[ (x - L) \cos \frac{n\pi x}{L} \Big|_0^L - \int_0^L \cos \frac{n\pi x}{L} dx \right] \\ &= \frac{12L^2}{n^3\pi^3} \left[ L - \frac{L}{n\pi} \sin \frac{n\pi x}{L} \Big|_0^L \right] = \frac{12L^3}{n^3\pi^3}. \end{aligned}$$

Therefore

$$S(x) = \frac{12L^3}{\pi^3} \sum_{n=1}^{\infty} \frac{1}{n^3} \sin \frac{n\pi x}{L}.$$

**Example 11.3.7** Find the mixed Fourier cosine expansion of  $f(x) = 3x^3 - 4Lx^2 + L^3$  on  $[0, L]$ .

**Solution** Since  $f'(0) = f'(L) = 0$  and  $f''(x) = 2(9x - 4L)$ , we see from (11.3.6) that

$$\begin{aligned} c_n &= -\frac{16L}{(2n-1)^2\pi^2} \int_0^L (9x - 4L) \cos \frac{(2n-1)\pi x}{2L} dx \\ &= -\frac{32L^2}{(2n-1)^3\pi^3} \left[ (9x - 4L) \sin \frac{(2n-1)\pi x}{2L} \Big|_0^L - 9 \int_0^L \sin \frac{(2n-1)\pi x}{2L} dx \right] \\ &= -\frac{32L^2}{(2n-1)^3\pi^3} \left[ (-1)^{n+1} 5L + \frac{18L}{(2n-1)\pi} \cos \frac{(2n-1)\pi x}{2L} \Big|_0^L \right] \\ &= \frac{32L^3}{(2n-1)^3\pi^3} \left[ (-1)^{n+1} 5 + \frac{18}{(2n-1)\pi} \right]. \end{aligned}$$

Therefore

$$C_M(x) = \frac{32L^3}{\pi^3} \sum_{n=1}^{\infty} \frac{1}{(2n-1)^3} \left[ (-1)^n 5 + \frac{18}{(2n-1)\pi} \right] \cos \frac{(2n-1)\pi x}{2L}.$$

**Example 11.3.8** Find the mixed Fourier sine expansion of

$$f(x) = x(2x^2 - 9Lx + 12L^2)$$

on  $[0, L]$ .

**Solution** Since  $f(0) = f'(L) = 0$ , and  $f''(x) = 6(2x - 3L)$ , we see from (11.3.7) that

$$\begin{aligned} d_n &= -\frac{48L}{(2n-1)^2\pi^2} \int_0^L (2x-3L) \sin \frac{(2n-1)\pi x}{2L} dx \\ &= \frac{96L^2}{(2n-1)^3\pi^3} \left[ (2x-3L) \cos \frac{(2n-1)\pi x}{2L} \Big|_0^L - 2 \int_0^L \cos \frac{(2n-1)\pi x}{2L} dx \right] \\ &= \frac{96L^2}{(2n-1)^3\pi^3} \left[ 3L - \frac{4L}{(2n-1)\pi} \sin \frac{(2n-1)\pi x}{2L} \Big|_0^L \right] \\ &= \frac{96L^3}{(2n-1)^3\pi^3} \left[ 3 + (-1)^n \frac{4}{(2n-1)\pi} \right]. \end{aligned}$$

Therefore

$$S_M(x) = \frac{96L^3}{\pi^3} \sum_{n=1}^{\infty} \frac{1}{(2n-1)^3} \left[ 3 + (-1)^n \frac{4}{(2n-1)\pi} \right] \sin \frac{(2n-1)\pi x}{2L}.$$

### 11.3 Exercises

In exercises marked by  $\boxed{\text{C}}$  graph  $f$  and some partial sums of the required series. If the interval is  $[0, L]$ , choose a specific value of  $L$  for the graph.

In Exercises 1-10 find the Fourier cosine series.

1.  $f(x) = x^2$ ;  $[0, L]$
2.  $\boxed{\text{C}}$   $f(x) = 1 - x$ ;  $[0, 1]$
3.  $\boxed{\text{C}}$   $f(x) = x^2 - 2Lx$ ;  $[0, L]$
4.  $f(x) = \sin kx$  ( $k \neq \text{integer}$ );  $[0, \pi]$
5.  $\boxed{\text{C}}$   $f(x) = \begin{cases} 1, & 0 \leq x \leq \frac{L}{2} \\ 0, & \frac{L}{2} < x < L; \end{cases}$   $[0, L]$
6.  $f(x) = x^2 - L^2$ ;  $[0, L]$
7.  $f(x) = (x-1)^2$ ;  $[0, 1]$
8.  $f(x) = e^x$ ;  $[0, \pi]$
9.  $\boxed{\text{C}}$   $f(x) = x(L-x)$ ;  $[0, L]$
10.  $\boxed{\text{C}}$   $f(x) = x(x-2L)$ ;  $[0, L]$

In Exercises 11-17 find the Fourier sine series.

11.  $\boxed{\text{C}}$   $f(x) = 1; \quad [0, L]$
12.  $\boxed{\text{C}}$   $f(x) = 1 - x; \quad [0, 1]$
13.  $f(x) = \cos kx$  ( $k \neq \text{integer}$ );  $[0, \pi]$
14.  $\boxed{\text{C}}$   $f(x) = \begin{cases} 1, & 0 \leq x \leq \frac{L}{2} \\ 0, & \frac{L}{2} < x < L; \end{cases} \quad [0, L]$
15.  $\boxed{\text{C}}$   $f(x) = \begin{cases} x, & 0 \leq x \leq \frac{L}{2} \\ L - x, & \frac{L}{2} \leq x \leq L; \end{cases} \quad [0, L].$
16.  $\boxed{\text{C}}$   $f(x) = x \sin x; \quad [0, \pi]$
17.  $f(x) = e^x; \quad [0, \pi]$

In Exercises 18-24 find the mixed Fourier cosine series.

18.  $\boxed{\text{C}}$   $f(x) = 1; \quad [0, L]$
19.  $f(x) = x^2; \quad [0, L]$
20.  $\boxed{\text{C}}$   $f(x) = x; \quad [0, 1]$
21.  $\boxed{\text{C}}$   $f(x) = \begin{cases} 1, & 0 \leq x \leq \frac{L}{2} \\ 0, & \frac{L}{2} < x < L; \end{cases} \quad [0, L]$
22.  $f(x) = \cos x; \quad [0, \pi]$
23.  $f(x) = \sin x; \quad [0, \pi]$
24.  $\boxed{\text{C}}$   $f(x) = x(L - x); \quad [0, L]$

In Exercises 25-30 find the mixed Fourier sine series.

25.  $\boxed{\text{C}}$   $f(x) = 1; \quad [0, L]$
26.  $f(x) = x^2; \quad [0, L]$
27.  $\boxed{\text{C}}$   $f(x) = \begin{cases} 1, & 0 \leq x \leq \frac{L}{2} \\ 0, & \frac{L}{2} < x < L; \end{cases} \quad [0, L]$
28.  $f(x) = \cos x; \quad [0, \pi]$
29.  $f(x) = \sin x; \quad [0, \pi]$
30.  $\boxed{\text{C}}$   $f(x) = x(L - x); \quad [0, L].$

In Exercises 31-34 use Theorem 11.3.5(a) to find the Fourier cosine series of  $f$  on  $[0, L]$ .

31.  $f(x) = 3x^2(x^2 - 2L^2)$
32.  $f(x) = x^3(3x - 4L)$
33.  $f(x) = x^2(3x^2 - 8Lx + 6L^2)$
34.  $f(x) = x^2(x - L)^2$
35. (a) Prove Theorem 11.3.5(b).

- (b) In addition to the assumptions of Theorem 11.3.5(b), suppose  $f''(0) = f''(L) = 0$ ,  $f'''$  is continuous, and  $f^{(4)}$  is piecewise continuous on  $[0, L]$ . Show that

$$b_n = \frac{2L^3}{n^4\pi^4} \int_0^L f^{(4)}(x) \sin \frac{n\pi x}{L} dx, \quad n \geq 1.$$

In Exercises 36–41 use Theorem 11.3.5(b) or, where applicable, Exercise 11.1.35(b), to find the Fourier sine series of  $f$  on  $[0, L]$ .

36.  $\boxed{\text{C}}$   $f(x) = x(L - x)$

37.  $\boxed{\text{C}}$   $f(x) = x^2(L - x)$

38.  $f(x) = x(L^2 - x^2)$

39.  $f(x) = x(x^3 - 2Lx^2 + L^3)$

40.  $f(x) = x(3x^4 - 10L^2x^2 + 7L^4)$

41.  $f(x) = x(3x^4 - 5Lx^3 + 2L^4)$

42. (a) Prove Theorem 11.3.5(c).

- (b) In addition to the assumptions of Theorem 11.3.5(c), suppose  $f''(L) = 0$ ,  $f''$  is continuous, and  $f'''$  is piecewise continuous on  $[0, L]$ . Show that

$$c_n = \frac{16L^2}{(2n-1)^3\pi^3} \int_0^L f'''(x) \sin \frac{(2n-1)\pi x}{2L} dx, \quad n \geq 1.$$

In Exercises 43–49 use Theorem 11.3.5(c) or, where applicable, Exercise 11.1.42(b), to find the mixed Fourier cosine series of  $f$  on  $[0, L]$ .

43.  $\boxed{\text{C}}$   $f(x) = x^2(L - x)$

44.  $f(x) = L^2 - x^2$

45.  $f(x) = L^3 - x^3$

46.  $f(x) = 2x^3 + 3Lx^2 - 5L^3$

47.  $f(x) = 4x^3 + 3Lx^2 - 7L^3$

48.  $f(x) = x^4 - 2Lx^3 + L^4$

49.  $f(x) = x^4 - 4Lx^3 + 6L^2x^2 - 3L^4$

50. (a) Prove Theorem 11.3.5(d).

- (b) In addition to the assumptions of Theorem 11.3.5(d), suppose  $f''(0) = 0$ ,  $f''$  is continuous, and  $f'''$  is piecewise continuous on  $[0, L]$ . Show that

$$d_n = -\frac{16L^2}{(2n-1)^3\pi^3} \int_0^L f'''(x) \cos \frac{(2n-1)\pi x}{2L} dx, \quad n \geq 1.$$

In Exercises 51–56 use Theorem 11.3.5(d) or, where applicable, Exercise 50(b), to find the mixed Fourier sine series of the  $f$  on  $[0, L]$ .

51.  $f(x) = x(2L - x)$

52.  $f(x) = x^2(3L - 2x)$

53.  $f(x) = (x - L)^3 + L^3$

54.  $f(x) = x(x^2 - 3L^2)$

55.  $f(x) = x^3(3x - 4L)$

56.  $f(x) = x(x^3 - 2Lx^2 + 2L^3)$

57. Show that the mixed Fourier cosine series of  $f$  on  $[0, L]$  is the restriction to  $[0, L]$  of the Fourier cosine series of

$$f_3(x) = \begin{cases} f(x), & 0 \leq x \leq L, \\ -f(2L - x), & L < x \leq 2L \end{cases}$$

on  $[0, 2L]$ . Use this to prove Theorem 11.3.3.

58. Show that the mixed Fourier sine series of  $f$  on  $[0, L]$  is the restriction to  $[0, L]$  of the Fourier sine series of

$$f_4(x) = \begin{cases} f(x), & 0 \leq x \leq L, \\ f(2L - x), & L < x \leq 2L \end{cases}$$

on  $[0, 2L]$ . Use this to prove Theorem 11.3.4.

59. Show that the Fourier sine series of  $f$  on  $[0, L]$  is the restriction to  $[0, L]$  of the Fourier sine series of

$$f_3(x) = \begin{cases} f(x), & 0 \leq x \leq L, \\ -f(2L - x), & L < x \leq 2L \end{cases}$$

on  $[0, 2L]$ .

60. Show that the Fourier cosine series of  $f$  on  $[0, L]$  is the restriction to  $[0, L]$  of the Fourier cosine series of

$$f_4(x) = \begin{cases} f(x), & 0 \leq x \leq L, \\ f(2L - x), & L < x \leq 2L \end{cases}$$

on  $[0, 2L]$ .

# CHAPTER 12

## Fourier Solutions of Partial Differential

IN THIS CHAPTER we use the series discussed in Chapter 11 to solve partial differential equations that arise in problems of mathematical physics.

SECTION 12.1 deals with the partial differential equation

$$u_t = a^2 u_{xx},$$

which arises in problems of conduction of heat.

SECTION 12.2 deals with the partial differential equation

$$u_{tt} = a^2 u_{xx},$$

which arises in the problem of the vibrating string.

SECTION 12.3 deals with the partial differential equation

$$u_{xx} + u_{yy} = 0,$$

which arises in steady state problems of heat conduction and potential theory.

SECTION 12.4 deals with the partial differential equation

$$u_{rr} + \frac{1}{r} u_r + \frac{1}{r^2} u_{\theta\theta} = 0,$$

which is the equivalent to the equation studied in Section 1.3 when the independent variables are polar coordinates.



## 12.1 THE HEAT EQUATION

We begin the study of partial differential equations with the problem of heat flow in a uniform bar of length  $L$ , situated on the  $x$  axis with one end at the origin and the other at  $x = L$  (Figure 12.1.1).

We assume that the bar is perfectly insulated except possibly at its endpoints, and that the temperature is constant on each cross section and therefore depends only on  $x$  and  $t$ . We also assume that the thermal properties of the bar are independent of  $x$  and  $t$ . In this case, it can be shown that the temperature  $u = u(x, t)$  at time  $t$  at a point  $x$  units from the origin satisfies the partial differential equation

$$u_t = a^2 u_{xx}, \quad 0 < x < L, \quad t > 0,$$

where  $a$  is a positive constant determined by the thermal properties. This is the *heat equation*.

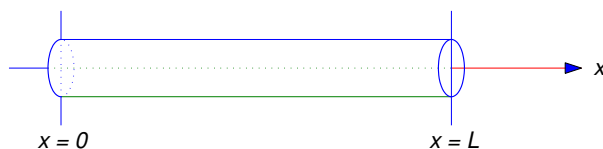

Figure 12.1.1 A uniform bar of length  $L$

To determine  $u$ , we must specify the temperature at every point in the bar when  $t = 0$ , say

$$u(x, 0) = f(x), \quad 0 \leq x \leq L.$$

We call this the *initial condition*. We must also specify *boundary conditions* that  $u$  must satisfy at the ends of the bar for all  $t > 0$ . We'll call this problem an *initial-boundary value problem*.

We begin with the boundary conditions  $u(0, t) = u(L, t) = 0$ , and write the initial-boundary value problem as

$$\begin{aligned} u_t &= a^2 u_{xx}, & 0 < x < L, & \quad t > 0, \\ u(0, t) &= 0, \quad u(L, t) = 0, & t > 0, \\ u(x, 0) &= f(x), & 0 \leq x \leq L. \end{aligned} \tag{12.1.1}$$

Our method of solving this problem is called *separation of variables* (not to be confused with method of separation of variables used in Section 2.2 for solving ordinary differential equations). We begin by looking for functions of the form

$$v(x, t) = X(x)T(t)$$

that are not identically zero and satisfy

$$v_t = a^2 v_{xx}, \quad v(0, t) = 0, \quad v(L, t) = 0$$

for all  $(x, t)$ . Since

$$v_t = XT' \quad \text{and} \quad v_{xx} = X''T,$$

$v_t = a^2v_{xx}$  if and only if

$$XT' = a^2X''T,$$

which we rewrite as

$$\frac{T'}{a^2T} = \frac{X''}{X}.$$

Since the expression on the left is independent of  $x$  while the one on the right is independent of  $t$ , this equation can hold for all  $(x, t)$  only if the two sides equal the same constant, which we call a *separation constant*, and write it as  $-\lambda$ ; thus,

$$\frac{X''}{X} = \frac{T'}{a^2T} = -\lambda.$$

This is equivalent to

$$X'' + \lambda X = 0$$

and

$$T' = -a^2\lambda T. \quad (12.1.2)$$

Since  $v(0, t) = X(0)T(t) = 0$  and  $v(L, t) = X(L)T(t) = 0$  and we don't want  $T$  to be identically zero,  $X(0) = 0$  and  $X(L) = 0$ . Therefore  $\lambda$  must be an eigenvalue of the boundary value problem

$$X'' + \lambda X = 0, \quad X(0) = 0, \quad X(L) = 0, \quad (12.1.3)$$

and  $X$  must be a  $\lambda$ -eigenfunction. From Theorem 11.1.2, the eigenvalues of (12.1.3) are  $\lambda_n = n^2\pi^2/L^2$ , with associated eigenfunctions

$$X_n = \sin \frac{n\pi x}{L}, \quad n = 1, 2, 3, \dots$$

Substituting  $\lambda = n^2\pi^2/L^2$  into (12.1.2) yields

$$T' = -(n^2\pi^2 a^2/L^2)T,$$

which has the solution

$$T_n = e^{-n^2\pi^2 a^2 t/L^2}.$$

Now let

$$v_n(x, t) = X_n(x)T_n(t) = e^{-n^2\pi^2 a^2 t/L^2} \sin \frac{n\pi x}{L}, \quad n = 1, 2, 3, \dots$$

Since

$$v_n(x, 0) = \sin \frac{n\pi x}{L},$$

$v_n$  satisfies (12.1.1) with  $f(x) = \sin n\pi x/L$ . More generally, if  $\alpha_1, \dots, \alpha_m$  are constants and

$$u_m(x, t) = \sum_{n=1}^m \alpha_n e^{-n^2\pi^2 a^2 t/L^2} \sin \frac{n\pi x}{L},$$

then  $u_m$  satisfies (12.1.1) with

$$f(x) = \sum_{n=1}^m \alpha_n \sin \frac{n\pi x}{L}.$$

This motivates the next definition.

**Definition 12.1.1** The formal solution of the initial-boundary value problem

$$\begin{aligned} u_t &= \alpha^2 u_{xx}, & 0 < x < L, & \quad t > 0, \\ u(0, t) &= 0, & u(L, t) &= 0, & \quad t > 0, \\ u(x, 0) &= f(x), & 0 \leq x \leq L \end{aligned} \quad (12.1.4)$$

is

$$u(x, t) = \sum_{n=1}^{\infty} \alpha_n e^{-n^2 \pi^2 \alpha^2 t / L^2} \sin \frac{n\pi x}{L}, \quad (12.1.5)$$

where

$$S(x) = \sum_{n=1}^{\infty} \alpha_n \sin \frac{n\pi x}{L}$$

is the Fourier sine series of  $f$  on  $[0, L]$ ; that is,

$$\alpha_n = \frac{2}{L} \int_0^L f(x) \sin \frac{n\pi x}{L} dx.$$

We use the term “formal solution” in this definition because it’s not in general true that the infinite series in (12.1.5) actually satisfies all the requirements of the initial-boundary value problem (12.1.4) when it does, we say that it’s an *actual solution* of (12.1.4).

Because of the negative exponentials in (12.1.5),  $u$  converges for all  $(x, t)$  with  $t > 0$  (Exercise 54). Since each term in (12.1.5) satisfies the heat equation and the boundary conditions in (12.1.4),  $u$  also has these properties if  $u_t$  and  $u_{xx}$  can be obtained by differentiating the series in (12.1.5) term by term once with respect to  $t$  and twice with respect to  $x$ , for  $t > 0$ . However, it’s not always legitimate to differentiate an infinite series term by term. The next theorem gives a useful sufficient condition for legitimacy of term by term differentiation of an infinite series. We omit the proof.

**Theorem 12.1.2** A convergent infinite series

$$W(z) = \sum_{n=1}^{\infty} w_n(z)$$

can be differentiated term by term on a closed interval  $[z_1, z_2]$  to obtain

$$W'(z) = \sum_{n=1}^{\infty} w'_n(z)$$

(where the derivatives at  $z = z_1$  and  $z = z_2$  are one-sided) provided that  $w'_n$  is continuous on  $[z_1, z_2]$  and

$$|w'_n(z)| \leq M_n, \quad z_1 \leq z \leq z_2, \quad n = 1, 2, 3, \dots,$$

where  $M_1, M_2, \dots, M_n, \dots$ , are constants such that the series  $\sum_{n=1}^{\infty} M_n$  converges.

Theorem 12.1.2, applied twice with  $z = x$  and once with  $z = t$ , shows that  $u_{xx}$  and  $u_t$  can be obtained by differentiating  $u$  term by term if  $t > 0$  (Exercise 54). Therefore  $u$  satisfies the heat equation and the boundary conditions in (12.1.4) for  $t > 0$ . Therefore, since  $u(x, 0) = S(x)$  for  $0 \leq x \leq L$ ,  $u$  is an actual solution of (12.1.4) if and only if  $S(x) = f(x)$  for  $0 \leq x \leq L$ . From Theorem 11.3.2, this is true if  $f$  is continuous and piecewise smooth on  $[0, L]$ , and  $f(0) = f(L) = 0$ .

In this chapter we’ll define formal solutions of several kinds of problems. When we ask you to solve such problems, we always mean that you should find a formal solution.

**Example 12.1.1** Solve (12.1.4) with  $f(x) = x(x^2 - 3Lx + 2L^2)$ .

**Solution** From Example 11.3.6, the Fourier sine series of  $f$  on  $[0, L]$  is

$$S(x) = \frac{12L^3}{\pi^3} \sum_{n=1}^{\infty} \frac{1}{n^3} \sin \frac{n\pi x}{L}.$$

Therefore

$$u(x, t) = \frac{12L^3}{\pi^3} \sum_{n=1}^{\infty} \frac{1}{n^3} e^{-n^2\pi^2 a^2 t/L^2} \sin \frac{n\pi x}{L}. \quad \blacksquare$$

If both ends of bar are insulated so that no heat can pass through them, then the boundary conditions are

$$u_x(0, t) = 0, \quad u_x(L, t) = 0, \quad t > 0.$$

We leave it to you (Exercise 1) to use the method of separation of variables and Theorem 11.1.3 to motivate the next definition.

**Definition 12.1.3** The formal solution of the initial-boundary value problem

$$\begin{aligned} u_t &= a^2 u_{xx}, & 0 < x < L, & \quad t > 0, \\ u_x(0, t) &= 0, \quad u_x(L, t) &= 0, & \quad t > 0, \\ u(x, 0) &= f(x), & 0 \leq x \leq L \end{aligned} \quad (12.1.6)$$

is

$$u(x, t) = \alpha_0 + \sum_{n=1}^{\infty} \alpha_n e^{-n^2\pi^2 a^2 t/L^2} \cos \frac{n\pi x}{L},$$

where

$$C(x) = \alpha_0 + \sum_{n=1}^{\infty} \alpha_n \cos \frac{n\pi x}{L}$$

is the Fourier cosine series of  $f$  on  $[0, L]$ ; that is,

$$\alpha_0 = \frac{1}{L} \int_0^L f(x) dx \quad \text{and} \quad \alpha_n = \frac{2}{L} \int_0^L f(x) \cos \frac{n\pi x}{L} dx, \quad n = 1, 2, 3, \dots$$

**Example 12.1.2** Solve (12.1.6) with  $f(x) = x$ .

**Solution** From Example 11.3.1, the Fourier cosine series of  $f$  on  $[0, L]$  is

$$C(x) = \frac{L}{2} - \frac{4L}{\pi^2} \sum_{n=1}^{\infty} \frac{1}{(2n-1)^2} \cos \frac{(2n-1)\pi x}{L}.$$

Therefore

$$u(x, t) = \frac{L}{2} - \frac{4L}{\pi^2} \sum_{n=1}^{\infty} \frac{1}{(2n-1)^2} e^{-(2n-1)^2\pi^2 a^2 t/L^2} \cos \frac{(2n-1)\pi x}{L}. \quad \blacksquare$$

We leave it to you (Exercise 2) to use the method of separation of variables and Theorem 11.1.4 to motivate the next definition.

**Definition 12.1.4** The formal solution of the initial-boundary value problem

$$\begin{aligned} u_t &= a^2 u_{xx}, & 0 < x < L, & \quad t > 0, \\ u(0, t) &= 0, \quad u_x(L, t) = 0, & t > 0, \\ u(x, 0) &= f(x), & 0 \leq x \leq L \end{aligned} \quad (12.1.7)$$

is

$$u(x, t) = \sum_{n=1}^{\infty} \alpha_n e^{-(2n-1)^2 \pi^2 a^2 t / 4L^2} \sin \frac{(2n-1)\pi x}{2L},$$

where

$$S_M(x) = \sum_{n=1}^{\infty} \alpha_n \sin \frac{(2n-1)\pi x}{2L}$$

is the mixed Fourier sine series of  $f$  on  $[0, L]$ ; that is,

$$\alpha_n = \frac{2}{L} \int_0^L f(x) \sin \frac{(2n-1)\pi x}{2L} dx.$$

**Example 12.1.3** Solve (12.1.7) with  $f(x) = x$ .

**Solution** From Example 11.3.4, the mixed Fourier sine series of  $f$  on  $[0, L]$  is

$$S_M(x) = -\frac{8L}{\pi^2} \sum_{n=1}^{\infty} \frac{(-1)^n}{(2n-1)^2} \sin \frac{(2n-1)\pi x}{2L}.$$

Therefore

$$u(x, t) = -\frac{8L}{\pi^2} \sum_{n=1}^{\infty} \frac{(-1)^n}{(2n-1)^2} e^{-(2n-1)^2 \pi^2 a^2 t / 4L^2} \sin \frac{(2n-1)\pi x}{2L}. \quad \blacksquare$$

Figure 12.1.2 shows a graph of  $u = u(x, t)$  plotted with respect to  $x$  for various values of  $t$ . The line  $y = x$  corresponds to  $t = 0$ . The other curves correspond to positive values of  $t$ . As  $t$  increases, the graphs approach the line  $u = 0$ .

We leave it to you (Exercise 3) to use the method of separation of variables and Theorem 11.1.5 to motivate the next definition.

**Definition 12.1.5** The formal solution of the initial-boundary value problem

$$\begin{aligned} u_t &= a^2 u_{xx}, & 0 < x < L, & \quad t > 0, \\ u_x(0, t) &= 0, \quad u(L, t) = 0, & t > 0, \\ u(x, 0) &= f(x), & 0 \leq x \leq L \end{aligned} \quad (12.1.8)$$

is

$$u(x, t) = \sum_{n=1}^{\infty} \alpha_n e^{-(2n-1)^2 \pi^2 a^2 t / 4L^2} \cos \frac{(2n-1)\pi x}{2L},$$

where

$$C_M(x) = \sum_{n=1}^{\infty} \alpha_n \cos \frac{(2n-1)\pi x}{2L}$$

is the mixed Fourier cosine series of  $f$  on  $[0, L]$ ; that is,

$$\alpha_n = \frac{2}{L} \int_0^L f(x) \cos \frac{(2n-1)\pi x}{2L} dx.$$

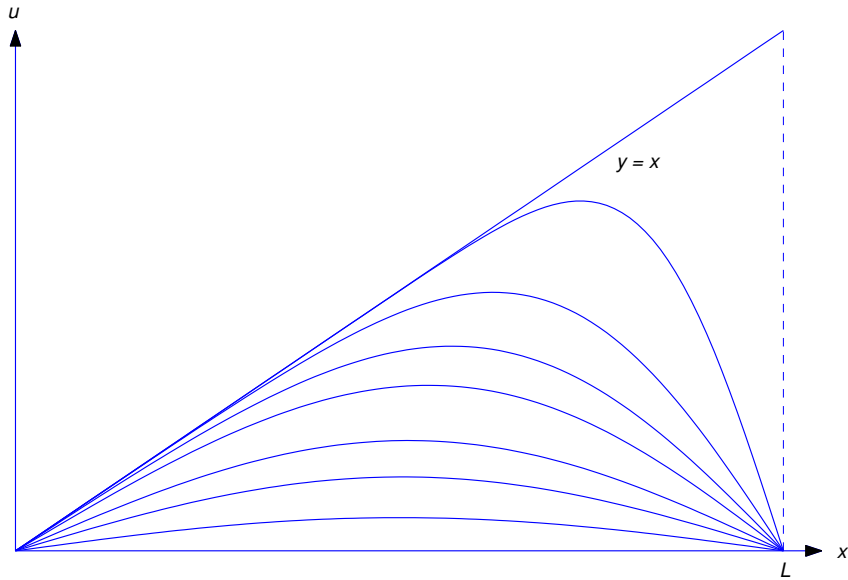

Figure 12.1.2

**Example 12.1.4** Solve (12.1.8) with  $f(x) = x - L$ .

**Solution** From Example 11.3.3, the mixed Fourier cosine series of  $f$  on  $[0, L]$  is

$$C_M(x) = -\frac{8L}{\pi^2} \sum_{n=1}^{\infty} \frac{1}{(2n-1)^2} \cos \frac{(2n-1)\pi x}{2L}.$$

Therefore

$$u(x, t) = -\frac{8L}{\pi^2} \sum_{n=1}^{\infty} \frac{1}{(2n-1)^2} e^{-(2n-1)^2 \pi^2 a^2 t / 4L^2} \cos \frac{(2n-1)\pi x}{2L}.$$

### Nonhomogeneous Problems

A problem of the form

$$\begin{aligned} u_t &= a^2 u_{xx} + h(x), & 0 < x < L, & \quad t > 0, \\ u(0, t) &= u_0, \quad u(L, t) = u_L, & t > 0, \\ u(x, 0) &= f(x), & 0 \leq x \leq L \end{aligned} \tag{12.1.9}$$

can be transformed to a problem that can be solved by separation of variables. We write

$$u(x, t) = v(x, t) + q(x), \tag{12.1.10}$$

where  $q$  is to be determined. Then

$$u_t = v_t \quad \text{and} \quad u_{xx} = v_{xx} + q''$$

so  $u$  satisfies (12.1.9) if  $v$  satisfies

$$\begin{aligned}v_t &= a^2 v_{xx} + a^2 q''(x) + h(x), & 0 < x < L, & \quad t > 0, \\v(0, t) &= u_0 - q(0), & v(L, t) &= u_L - q(L), & \quad t > 0, \\v(x, 0) &= f(x) - q(x), & 0 \leq x \leq L.\end{aligned}$$

This reduces to

$$\begin{aligned}v_t &= a^2 v_{xx}, & 0 < x < L, & \quad t > 0, \\v(0, t) &= 0, & v(L, t) &= 0, & \quad t > 0, \\v(x, 0) &= f(x) - q(x), & 0 \leq x \leq L\end{aligned} \tag{12.1.11}$$

if

$$a^2 q'' + h(x) = 0, \quad q(0) = u_0, \quad q(L) = u_L.$$

We can obtain  $q$  by integrating  $q'' = -h/a^2$  twice and choosing the constants of integration so that  $q(0) = u_0$  and  $q(L) = u_L$ . Then we can solve (12.1.11) for  $v$  by separation of variables, and (12.1.10) is the solution of (12.1.9).

**Example 12.1.5** Solve

$$\begin{aligned}u_t &= u_{xx} - 2, & 0 < x < 1, & \quad t > 0, \\u(0, t) &= -1, & u(1, t) &= 1, & \quad t > 0, \\u(x, 0) &= x^3 - 2x^2 + 3x - 1, & 0 \leq x \leq 1.\end{aligned}$$

**Solution** We leave it to you to show that

$$q(x) = x^2 + x - 1$$

satisfies

$$q'' - 2 = 0, \quad q(0) = -1, \quad q(1) = 1.$$

Therefore

$$u(x, t) = v(x, t) + x^2 + x - 1,$$

where

$$\begin{aligned}v_t &= v_{xx}, & 0 < x < 1, & \quad t > 0, \\v(0, t) &= 0, & v(1, t) &= 0, & \quad t > 0,\end{aligned}$$

and

$$v(x, 0) = x^3 - 2x^2 + 3x - 1 - x^2 - x + 1 = x(x^2 - 3x + 2).$$

From Example 12.1.1 with  $a = 1$  and  $L = 1$ ,

$$v(x, t) = \frac{12}{\pi^3} \sum_{n=1}^{\infty} \frac{1}{n^3} e^{-n^2 \pi^2 t} \sin n\pi x.$$

Therefore

$$u(x, t) = x^2 + x - 1 + \frac{12}{\pi^3} \sum_{n=1}^{\infty} \frac{1}{n^3} e^{-n^2 \pi^2 t} \sin n\pi x. \quad \blacksquare$$

A similar procedure works if the boundary conditions in (12.1.11) are replaced by mixed boundary conditions

$$u_x(0, t) = u_0, \quad u(L, t) = u_L, \quad t > 0$$

or

$$u(0, t) = u_0, \quad u_x(L, t) = u_L, \quad t > 0;$$

however, this isn't true in general for the boundary conditions

$$u_x(0, t) = u_0, \quad u_x(L, t) = u_L, \quad t > 0.$$

(See Exercise 47.)

### USING TECHNOLOGY

Numerical experiments can enhance your understanding of the solutions of initial-boundary value problems. To be specific, consider the formal solution

$$u(x, t) = \sum_{n=1}^{\infty} \alpha_n e^{-n^2 \pi^2 a^2 t / L^2} \sin \frac{n\pi x}{L},$$

of (12.1.4), where

$$S(x) = \sum_{n=1}^{\infty} \alpha_n \sin \frac{n\pi x}{L}$$

is the Fourier sine series of  $f$  on  $[0, L]$ . Consider the  $m$ -th partial sum

$$u_m(x, t) = \sum_{n=1}^m \alpha_n e^{-n^2 \pi^2 a^2 t / L^2} \sin \frac{n\pi x}{L}. \quad (12.1.12)$$

For several fixed values of  $t$  (including  $t = 0$ ), graph  $u_m(x, t)$  versus  $x$ . In some cases it may be useful to graph the curves corresponding to the various values of  $t$  on the same axes in other cases you may want to graph the various curves successively (for increasing values of  $t$ ), and create a primitive motion picture on your monitor. Repeat this experiment for several values of  $m$ , to compare how the results depend upon  $m$  for small and large values of  $t$ . However, keep in mind that the meanings of “small” and “large” in this case depend upon the constants  $a^2$  and  $L^2$ . A good way to handle this is to rewrite (12.1.12) as

$$u_m(x, t) = \sum_{n=1}^m \alpha_n e^{-n^2 \tau} \sin \frac{n\pi x}{L},$$

where

$$\tau = \frac{\pi^2 a^2 t}{L^2}, \quad (12.1.13)$$

and graph  $u_m$  versus  $x$  for selected values of  $\tau$ .

These comments also apply to the situations considered in Definitions 12.1.3-12.1.5, except that (12.1.13) should be replaced by

$$\tau = \frac{\pi^2 a^2 t}{4L^2},$$

in Definitions 12.1.4 and 12.1.5.

In some of the exercises we say “perform numerical experiments.” This means that you should perform the computations just described with the formal solution obtained in the exercise.



## 12.1 Exercises

---

1. Explain Definition 12.1.3.
2. Explain Definition 12.1.4.
3. Explain Definition 12.1.5.
4. C Perform numerical experiments with the formal solution obtained in Example 12.1.1.
5. C Perform numerical experiments with the formal solution obtained in Example 12.1.2.
6. C Perform numerical experiments with the formal solution obtained in Example 12.1.3.
7. C Perform numerical experiments with the formal solution obtained in Example 12.1.4.

In Exercises 8-42 solve the initial-boundary value problem. Where indicated by C, perform numerical experiments. To simplify the computation of coefficients in some of these problems, check first to see if  $u(x, 0)$  is a polynomial that satisfies the boundary conditions. If it does, apply Theorem 11.3.5; also, see Exercises 11.3.35(b), 11.3.42(b), and 11.3.50(b).

8.  $u_t = u_{xx}, \quad 0 < x < 1, \quad t > 0,$   
 $u(0, t) = 0, \quad u(1, t) = 0, \quad t > 0,$   
 $u(x, 0) = x(1 - x), \quad 0 \leq x \leq 1$
9.  $u_t = 9u_{xx}, \quad 0 < x < 4, \quad t > 0,$   
 $u(0, t) = 0, \quad u(4, t) = 0, \quad t > 0,$   
 $u(x, 0) = 1, \quad 0 \leq x \leq 4$
10.  $u_t = 3u_{xx}, \quad 0 < x < \pi, \quad t > 0,$   
 $u(0, t) = 0, \quad u(\pi, t) = 0, \quad t > 0,$   
 $u(x, 0) = x \sin x, \quad 0 \leq x \leq \pi$
11. C  $u_t = 9u_{xx}, \quad 0 < x < 2, \quad t > 0,$   
 $u(0, t) = 0, \quad u(2, t) = 0, \quad t > 0,$   
 $u(x, 0) = x^2(2 - x), \quad 0 \leq x \leq 2$
12.  $u_t = 4u_{xx}, \quad 0 < x < 3, \quad t > 0,$   
 $u(0, t) = 0, \quad u(3, t) = 0, \quad t > 0,$   
 $u(x, 0) = x(9 - x^2), \quad 0 \leq x \leq 3$
13.  $u_t = 4u_{xx}, \quad 0 < x < 2, \quad t > 0,$   
 $u(0, t) = 0, \quad u(2, t) = 0, \quad t > 0,$   
 $u(x, 0) = \begin{cases} x, & 0 \leq x \leq 1, \\ 2 - x, & 1 \leq x \leq 2. \end{cases}$
14.  $u_t = 7u_{xx}, \quad 0 < x < 1, \quad t > 0,$   
 $u(0, t) = 0, \quad u(1, t) = 0, \quad t > 0,$   
 $u(x, 0) = x(3x^4 - 10x^2 + 7), \quad 0 \leq x \leq 1$
15.  $u_t = 5u_{xx}, \quad 0 < x < 1, \quad t > 0,$   
 $u(0, t) = 0, \quad u(1, t) = 0, \quad t > 0,$   
 $u(x, 0) = x(x^3 - 2x^2 + 1), \quad 0 \leq x \leq 1$
16.  $u_t = 2u_{xx}, \quad 0 < x < 1, \quad t > 0,$   
 $u(0, t) = 0, \quad u(1, t) = 0, \quad t > 0,$   
 $u(x, 0) = x(3x^4 - 5x^3 + 2), \quad 0 \leq x \leq 1$

17.  $\square$   $u_t = 9u_{xx}$ ,  $0 < x < 4$ ,  $t > 0$ ,  
 $u_x(0, t) = 0$ ,  $u_x(4, t) = 0$ ,  $t > 0$ ,  
 $u(x, 0) = x^2$ ,  $0 \leq x \leq 4$
18.  $u_t = 4u_{xx}$ ,  $0 < x < 2$ ,  $t > 0$ ,  
 $u_x(0, t) = 0$ ,  $u_x(2, t) = 0$ ,  $t > 0$ ,  
 $u(x, 0) = x(x - 4)$ ,  $0 \leq x \leq 2$
19.  $\square$   $u_t = 9u_{xx}$ ,  $0 < x < 1$ ,  $t > 0$ ,  
 $u_x(0, t) = 0$ ,  $u_x(1, t) = 0$ ,  $t > 0$ ,  
 $u(x, 0) = x(1 - x)$ ,  $0 \leq x \leq 1$
20.  $u_t = 3u_{xx}$ ,  $0 < x < 2$ ,  $t > 0$ ,  
 $u_x(0, t) = 0$ ,  $u_x(2, t) = 0$ ,  $t > 0$ ,  
 $u(x, 0) = 2x^2(3 - x)$ ,  $0 \leq x \leq 2$
21.  $u_t = 5u_{xx}$ ,  $0 < x < \sqrt{2}$ ,  $t > 0$ ,  
 $u_x(0, t) = 0$ ,  $u_x(\sqrt{2}, t) = 0$ ,  $t > 0$ ,  
 $u(x, 0) = 3x^2(x^2 - 4)$ ,  $0 \leq x \leq \sqrt{2}$
22.  $\square$   $u_t = 3u_{xx}$ ,  $0 < x < 1$ ,  $t > 0$ ,  
 $u_x(0, t) = 0$ ,  $u_x(1, t) = 0$ ,  $t > 0$ ,  
 $u(x, 0) = x^3(3x - 4)$ ,  $0 \leq x \leq 1$
23.  $u_t = u_{xx}$ ,  $0 < x < 1$ ,  $t > 0$ ,  
 $u_x(0, t) = 0$ ,  $u_x(1, t) = 0$ ,  $t > 0$ ,  
 $u(x, 0) = x^2(3x^2 - 8x + 6)$ ,  $0 \leq x \leq 1$
24.  $u_t = u_{xx}$ ,  $0 < x < \pi$ ,  $t > 0$ ,  
 $u_x(0, t) = 0$ ,  $u_x(\pi, t) = 0$ ,  $t > 0$ ,  
 $u(x, 0) = x^2(x - \pi)^2$ ,  $0 \leq x \leq \pi$
25.  $u_t = u_{xx}$ ,  $0 < x < 1$ ,  $t > 0$ ,  
 $u(0, t) = 0$ ,  $u_x(1, t) = 0$ ,  $t > 0$ ,  
 $u(x, 0) = \sin \pi x$ ,  $0 \leq x \leq 1$
26.  $\square$   $u_t = 3u_{xx}$ ,  $0 < x < \pi$ ,  $t > 0$ ,  
 $u(0, t) = 0$ ,  $u_x(\pi, t) = 0$ ,  $t > 0$ ,  
 $u(x, 0) = x(\pi - x)$ ,  $0 \leq x \leq \pi$
27.  $u_t = 5u_{xx}$ ,  $0 < x < 2$ ,  $t > 0$ ,  
 $u(0, t) = 0$ ,  $u_x(2, t) = 0$ ,  $t > 0$ ,  
 $u(x, 0) = x(4 - x)$ ,  $0 \leq x \leq 2$
28.  $u_t = u_{xx}$ ,  $0 < x < 1$ ,  $t > 0$ ,  
 $u(0, t) = 0$ ,  $u_x(1, t) = 0$ ,  $t > 0$ ,  
 $u(x, 0) = x^2(3 - 2x)$ ,  $0 \leq x \leq 1$
29.  $u_t = u_{xx}$ ,  $0 < x < 1$ ,  $t > 0$ ,  
 $u(0, t) = 0$ ,  $u_x(1, t) = 0$ ,  $t > 0$ ,  
 $u(x, 0) = (x - 1)^3 + 1$ ,  $0 \leq x \leq 1$
30.  $\square$   $u_t = u_{xx}$ ,  $0 < x < 1$ ,  $t > 0$ ,  
 $u(0, t) = 0$ ,  $u_x(1, t) = 0$ ,  $t > 0$ ,  
 $u(x, 0) = x(x^2 - 3)$ ,  $0 \leq x \leq 1$
31.  $u_t = u_{xx}$ ,  $0 < x < 1$ ,  $t > 0$ ,  
 $u(0, t) = 0$ ,  $u_x(1, t) = 0$ ,  $t > 0$ ,  
 $u(x, 0) = x^3(3x - 4)$ ,  $0 \leq x \leq 1$

32.  $u_t = u_{xx}$ ,  $0 < x < 1$ ,  $t > 0$ ,  
 $u(0, t) = 0$ ,  $u_x(1, t) = 0$ ,  $t > 0$ ,  
 $u(x, 0) = x(x^3 - 2x^2 + 2)$ ,  $0 \leq x \leq 1$
33.  $u_t = 3u_{xx}$ ,  $0 < x < \pi$ ,  $t > 0$ ,  
 $u_x(0, t) = 0$ ,  $u(\pi, t) = 0$ ,  $t > 0$ ,  
 $u(x, 0) = x^2(\pi - x)$ ,  $0 \leq x \leq \pi$
34.  $u_t = 16u_{xx}$ ,  $0 < x < 2\pi$ ,  $t > 0$ ,  
 $u_x(0, t) = 0$ ,  $u(2\pi, t) = 0$ ,  $t > 0$ ,  
 $u(x, 0) = 4$ ,  $0 \leq x \leq 2\pi$
35.  $u_t = 9u_{xx}$ ,  $0 < x < 4$ ,  $t > 0$ ,  
 $u_x(0, t) = 0$ ,  $u(4, t) = 0$ ,  $t > 0$ ,  
 $u(x, 0) = x^2$ ,  $0 \leq x \leq 4$
36.  $\square$   $u_t = 3u_{xx}$ ,  $0 < x < 1$ ,  $t > 0$ ,  
 $u_x(0, t) = 0$ ,  $u(1, t) = 0$ ,  $t > 0$ ,  
 $u(x, 0) = 1 - x$ ,  $0 \leq x \leq 1$
37.  $u_t = u_{xx}$ ,  $0 < x < 1$ ,  $t > 0$ ,  
 $u_x(0, t) = 0$ ,  $u(1, t) = 0$ ,  $t > 0$ ,  
 $u(x, 0) = 1 - x^3$ ,  $0 \leq x \leq 1$
38.  $u_t = 7u_{xx}$ ,  $0 < x < \pi$ ,  $t > 0$ ,  
 $u_x(0, t) = 0$ ,  $u(\pi, t) = 0$ ,  $t > 0$ ,  
 $u(x, 0) = \pi^2 - x^2$ ,  $0 \leq x \leq \pi$
39.  $u_t = u_{xx}$ ,  $0 < x < 1$ ,  $t > 0$ ,  
 $u_x(0, t) = 0$ ,  $u(1, t) = 0$ ,  $t > 0$ ,  
 $u(x, 0) = 4x^3 + 3x^2 - 7$ ,  $0 \leq x \leq 1$
40.  $u_t = u_{xx}$ ,  $0 < x < 1$ ,  $t > 0$ ,  
 $u_x(0, t) = 0$ ,  $u(1, t) = 0$ ,  $t > 0$ ,  
 $u(x, 0) = 2x^3 + 3x^2 - 5$ ,  $0 \leq x \leq 1$
41.  $\square$   $u_t = u_{xx}$ ,  $0 < x < 1$ ,  $t > 0$ ,  
 $u_x(0, t) = 0$ ,  $u(1, t) = 0$ ,  $t > 0$ ,  
 $u(x, 0) = x^4 - 4x^3 + 6x^2 - 3$ ,  $0 \leq x \leq 1$
42.  $u_t = u_{xx}$ ,  $0 < x < 1$ ,  $t > 0$ ,  
 $u_x(0, t) = 0$ ,  $u(1, t) = 0$ ,  $t > 0$ ,  
 $u(x, 0) = x^4 - 2x^3 + 1$ ,  $0 \leq x \leq 1$

In Exercises 43-46 solve the initial-boundary value problem. Perform numerical experiments for specific values of  $L$  and  $a$ .

43.  $\square$   $u_t = a^2 u_{xx}$ ,  $0 < x < L$ ,  $t > 0$ ,  
 $u_x(0, t) = 0$ ,  $u_x(L, t) = 0$ ,  $t > 0$ ,  
 $u(x, 0) = \begin{cases} 1, & 0 \leq x \leq \frac{L}{2}, \\ 0, & \frac{L}{2} < x < L \end{cases}$
44.  $\square$   $u_t = a^2 u_{xx}$ ,  $0 < x < L$ ,  $t > 0$ ,  
 $u(0, t) = 0$ ,  $u(L, t) = 0$ ,  $t > 0$ ,  
 $u(x, 0) = \begin{cases} 1, & 0 \leq x \leq \frac{L}{2}, \\ 0, & \frac{L}{2} < x < L \end{cases}$

45.  $\boxed{\text{C}}$   $u_t = a^2 u_{xx}, \quad 0 < x < L, \quad t > 0,$   
 $u_x(0, t) = 0, \quad u(L, t) = 0, \quad t > 0,$   
 $u(x, 0) = \begin{cases} 1, & 0 \leq x \leq \frac{L}{2}, \\ 0, & \frac{L}{2} < x < L \end{cases}$

46.  $\boxed{\text{C}}$   $u_t = a^2 u_{xx}, \quad 0 < x < L, \quad t > 0,$   
 $u(0, t) = 0, \quad u_x(L, t) = 0, \quad t > 0,$   
 $u(x, 0) = \begin{cases} 1, & 0 \leq x \leq \frac{L}{2}, \\ 0, & \frac{L}{2} < x < L \end{cases}$

47. Let  $h$  be continuous on  $[0, L]$  and let  $u_0, u_L$ , and  $a$  be constants, with  $a > 0$ . Show that it's always possible to find a function  $q$  that satisfies **(a)**, **(b)**, or **(c)**, but that this isn't so for **(d)**.

**(a)**  $a^2 q'' + h = 0, \quad q(0) = u_0, \quad q(L) = u_L$

**(b)**  $a^2 q'' + h = 0, \quad q'(0) = u_0, \quad q(L) = u_L$

**(c)**  $a^2 q'' + h = 0, \quad q(0) = u_0, \quad q'(L) = u_L$

**(d)**  $a^2 q'' + h = 0, \quad q'(0) = u_0, \quad q'(L) = u_L$

In Exercises 48-53 solve the nonhomogeneous initial-boundary value problem

48.  $u_t = 9u_{xx} - 54x, \quad 0 < x < 4, \quad t > 0,$   
 $u(0, t) = 1, \quad u(4, t) = 61, \quad t > 0,$   
 $u(x, 0) = 2 - x + x^3, \quad 0 \leq x \leq 4$

49.  $u_t = u_{xx} - 2, \quad 0 < x < 1, \quad t > 0,$   
 $u(0, t) = 1, \quad u(1, t) = 3, \quad t > 0,$   
 $u(x, 0) = 2x^2 + 1, \quad 0 \leq x \leq 1$

50.  $u_t = 3u_{xx} - 18x, \quad 0 < x < 1, \quad t > 0,$   
 $u_x(0, t) = -1, \quad u(1, t) = -1, \quad t > 0,$   
 $u(x, 0) = x^3 - 2x, \quad 0 \leq x \leq 1$

51.  $u_t = 9u_{xx} - 18, \quad 0 < x < 4, \quad t > 0,$   
 $u_x(0, t) = -1, \quad u(4, t) = 10, \quad t > 0,$   
 $u(x, 0) = 2x^2 - x - 2, \quad 0 \leq x \leq 4$

52.  $u_t = u_{xx} + \pi^2 \sin \pi x, \quad 0 < x < 1, \quad t > 0,$   
 $u(0, t) = 0, \quad u_x(1, t) = -\pi, \quad t > 0,$   
 $u(x, 0) = 2 \sin \pi x, \quad 0 \leq x \leq 1$

53.  $u_t = u_{xx} - 6x, \quad 0 < x < L, \quad t > 0,$   
 $u(0, t) = 3, \quad u_x(1, t) = 2, \quad t > 0,$   
 $u(x, 0) = x^3 - x^2 + x + 3, \quad 0 \leq x \leq 1$

54. In this exercise take it as given that the infinite series  $\sum_{n=1}^{\infty} n^p e^{-qn^2}$  converges for all  $p$  if  $q > 0$ , and, where appropriate, use the comparison test for absolute convergence of an infinite series.

Let

$$u(x, t) = \sum_{n=1}^{\infty} \alpha_n e^{-n^2 \pi^2 a^2 t / L^2} \sin \frac{n\pi x}{L}$$

where

$$\alpha_n = \frac{2}{L} \int_0^L f(x) \sin \frac{n\pi x}{L} dx$$

and  $f$  is piecewise smooth on  $[0, L]$ .

- (a) Show that  $u$  is defined for  $(x, t)$  such that  $t > 0$ .  
 (b) For fixed  $t > 0$ , use Theorem 12.1.2 with  $z = x$  to show that

$$u_x(x, t) = \frac{\pi}{L} \sum_{n=1}^{\infty} n \alpha_n e^{-n^2 \pi^2 a^2 t / L^2} \cos \frac{n \pi x}{L}, \quad -\infty < x < \infty.$$

- (c) Starting from the result of (a), use Theorem 12.1.2 with  $z = x$  to show that, for a fixed  $t > 0$ ,

$$u_{xx}(x, t) = -\frac{\pi^2}{L^2} \sum_{n=1}^{\infty} n^2 \alpha_n e^{-n^2 \pi^2 a^2 t / L^2} \sin \frac{n \pi x}{L}, \quad -\infty < x < \infty.$$

- (d) For fixed but arbitrary  $x$ , use Theorem 12.1.2 with  $z = t$  to show that

$$u_t(x, t) = -\frac{\pi^2 a^2}{L^2} \sum_{n=1}^{\infty} n^2 \alpha_n e^{-n^2 \pi^2 a^2 t / L^2} \sin \frac{n \pi x}{L},$$

if  $t > t_0 > 0$ , where  $t_0$  is an arbitrary positive number. Then argue that since  $t_0$  is arbitrary, the conclusion holds for all  $t > 0$ .

- (e) Conclude from (c) and (d) that

$$u_t = a^2 u_{xx}, \quad -\infty < x < \infty, \quad t > 0.$$

By repeatedly applying the arguments in (a) and (c), it can be shown that  $u$  can be differentiated term by term any number of times with respect to  $x$  and/or  $t$  if  $t > 0$ .

## 12.2 THE WAVE EQUATION

In this section we consider initial-boundary value problems of the form

$$\begin{aligned} u_{tt} &= a^2 u_{xx}, & 0 < x < L, & \quad t > 0, \\ u(0, t) &= 0, \quad u(L, t) = 0, & & \quad t > 0, \\ u(x, 0) &= f(x), \quad u_t(x, 0) = g(x), & & \quad 0 \leq x \leq L, \end{aligned} \tag{12.2.1}$$

where  $a$  is a constant and  $f$  and  $g$  are given functions of  $x$ .

The partial differential equation  $u_{tt} = a^2 u_{xx}$  is called the *wave equation*. It is necessary to specify both  $f$  and  $g$  because the wave equation is a second order equation in  $t$  for each fixed  $x$ .

This equation and its generalizations

$$u_{tt} = a^2(u_{xx} + u_{yy}) \quad \text{and} \quad u_{tt} = a^2(u_{xx} + u_{yy} + u_{zz})$$

to two and three space dimensions have important applications to the the propagation of electromagnetic, sonic, and water waves.

### The Vibrating String

We motivate the study of the wave equation by considering its application to the vibrations of a string – such as a violin string – tightly stretched in equilibrium along the  $x$ -axis in the  $xu$ -plane and tied to the points  $(0, 0)$  and  $(L, 0)$  (Figure 12.2.1).

If the string is plucked in the vertical direction and released at time  $t = 0$ , it will oscillate in the  $xu$ -plane. Let  $u(x, t)$  denote the displacement of the point on the string above (or below) the abscissa  $x$  at time  $t$ .

We'll show that it's reasonable to assume that  $u$  satisfies the wave equation under the following assumptions:

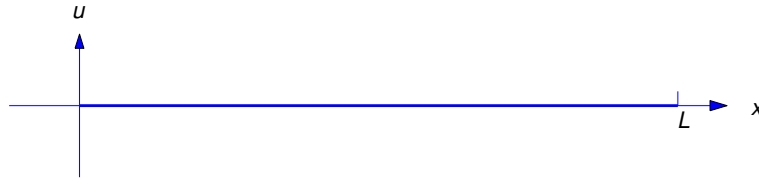

Figure 12.2.1 A stretched string

1. The mass density (mass per unit length)  $\rho$  of the string is constant throughout the string.
2. The tension  $T$  induced by tightly stretching the string along the  $x$ -axis is so great that all other forces, such as gravity and air resistance, can be neglected.
3. The tension at any point on the string acts along the tangent to the string at that point, and the magnitude of its horizontal component is always equal to  $T$ , the tension in the string in equilibrium.
4. The slope of the string at every point remains sufficiently small so that we can make the approximation

$$\sqrt{1 + u_x^2} \approx 1. \quad (12.2.2)$$

Figure 12.2.2 shows a segment of the displaced string at a time  $t > 0$ . (Don't think that the figure is necessarily inconsistent with Assumption 4; we exaggerated the slope for clarity.)

The vectors  $\mathbf{T}_1$  and  $\mathbf{T}_2$  are the forces due to tension, acting along the tangents to the segment at its endpoints. From Newton's second law of motion,  $\mathbf{T}_1 - \mathbf{T}_2$  is equal to the mass times the acceleration of the center of mass of the segment. The horizontal and vertical components of  $\mathbf{T}_1 - \mathbf{T}_2$  are

$$|\mathbf{T}_2| \cos \theta_2 - |\mathbf{T}_1| \cos \theta_1 \quad \text{and} \quad |\mathbf{T}_2| \sin \theta_2 - |\mathbf{T}_1| \sin \theta_1,$$

respectively. Since

$$|\mathbf{T}_2| \cos \theta_2 = |\mathbf{T}_1| \cos \theta_1 = T \quad (12.2.3)$$

by assumption, the net horizontal force is zero, so there's no horizontal acceleration. Since the initial horizontal velocity is zero, there's no horizontal motion.

Applying Newton's second law of motion in the vertical direction yields

$$|\mathbf{T}_2| \sin \theta_2 - |\mathbf{T}_1| \sin \theta_1 = \rho \Delta s u_{tt}(\bar{x}, t), \quad (12.2.4)$$

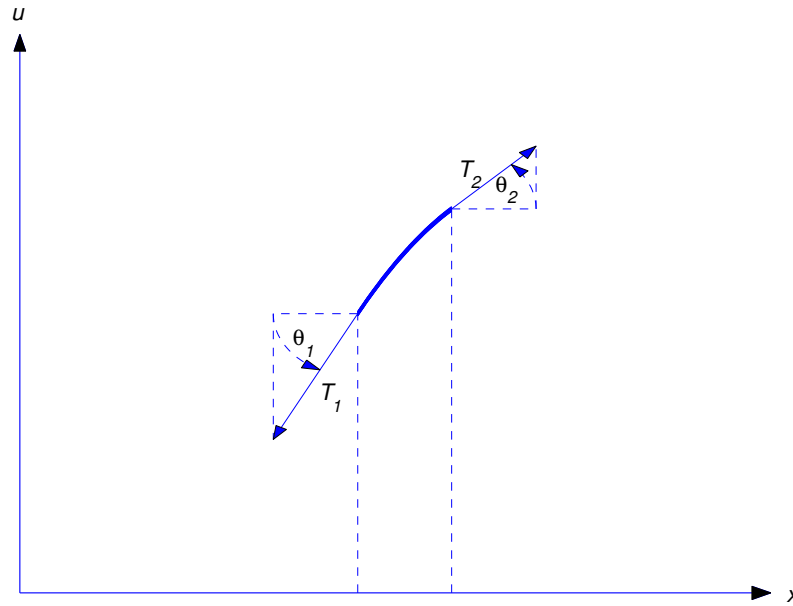

Figure 12.2.2 A segment of the displaced string

where  $\Delta s$  is the length of the segment and  $\bar{x}$  is the abscissa of the center of mass; hence,

$$x < \bar{x} < x + \Delta x.$$

From calculus, we know that

$$\Delta s = \int_x^{x+\Delta x} \sqrt{1 + u_x^2(\sigma, t)} \, d\sigma;$$

however, because of (12.2.2), we make the approximation

$$\Delta s \approx \int_x^{x+\Delta x} 1 \, d\sigma = \Delta x,$$

so (12.2.4) becomes

$$|\mathbf{T}_2| \sin \theta_2 - |\mathbf{T}_1| \sin \theta_1 = \rho \Delta x u_{tt}(\bar{x}, t).$$

Therefore

$$\frac{|\mathbf{T}_2| \sin \theta_2 - |\mathbf{T}_1| \sin \theta_1}{\Delta x} = \rho u_{tt}(\bar{x}, t).$$

Recalling (12.2.3), we divide by  $T$  to obtain

$$\frac{\tan \theta_2 - \tan \theta_1}{\Delta x} = \frac{\rho}{T} u_{tt}(\bar{x}, t). \quad (12.2.5)$$

Since  $\tan \theta_1 = u_x(x, t)$  and  $\tan \theta_2 = u_x(x + \Delta x, t)$ , (12.2.5) is equivalent to

$$\frac{u_x(x + \Delta x) - u_x(x, t)}{\Delta x} = \frac{\rho}{T} u_{tt}(\bar{x}, t).$$

Letting  $\Delta x \rightarrow 0$  yields

$$u_{xx}(x, t) = \frac{\rho}{T}u_{tt}(x, t),$$

which we rewrite as  $u_{tt} = a^2u_{xx}$ , with  $a^2 = T/\rho$ .

### The Formal Solution

As in Section 12.1, we use separation of variables to obtain a suitable definition for the formal solution of (12.2.1). We begin by looking for functions of the form  $v(x, t) = X(x)T(t)$  that are not identically zero and satisfy

$$v_{tt} = a^2v_{xx}, \quad v(0, t) = 0, \quad v(L, t) = 0$$

for all  $(x, t)$ . Since

$$v_{tt} = XT'' \quad \text{and} \quad v_{xx} = X''T,$$

$v_{tt} = a^2v_{xx}$  if and only if

$$XT'' = a^2X''T,$$

which we rewrite as

$$\frac{T''}{a^2T} = \frac{X''}{X}.$$

For this to hold for all  $(x, t)$ , the two sides must equal the same constant; thus,

$$\frac{X''}{X} = \frac{T''}{a^2T} = -\lambda,$$

which is equivalent to

$$X'' + \lambda X = 0$$

and

$$T'' + a^2\lambda T = 0. \tag{12.2.6}$$

Since  $v(0, t) = X(0)T(t) = 0$  and  $v(L, t) = X(L)T(t) = 0$  and we don't want  $T$  to be identically zero,  $X(0) = 0$  and  $X(L) = 0$ . Therefore  $\lambda$  must be an eigenvalue of

$$X'' + \lambda X = 0, \quad X(0) = 0, \quad X(L) = 0, \tag{12.2.7}$$

and  $X$  must be a  $\lambda$ -eigenfunction. From Theorem 11.1.2, the eigenvalues of (12.2.7) are  $\lambda_n = n^2\pi^2/L^2$ , with associated eigenfunctions

$$X_n = \sin \frac{n\pi x}{L}, \quad n = 1, 2, 3, \dots$$

Substituting  $\lambda = n^2\pi^2/L^2$  into (12.2.6) yields

$$T'' + (n^2\pi^2a^2/L^2)T = 0,$$

which has the general solution

$$T_n = \alpha_n \cos \frac{n\pi at}{L} + \frac{\beta_n L}{n\pi a} \sin \frac{n\pi at}{L},$$

where  $\alpha_n$  and  $\beta_n$  are constants. Now let

$$v_n(x, t) = X_n(x)T_n(t) = \left( \alpha_n \cos \frac{n\pi at}{L} + \frac{\beta_n L}{n\pi a} \sin \frac{n\pi at}{L} \right) \sin \frac{n\pi x}{L}.$$



Then

$$\frac{\partial v_n}{\partial t}(x, t) = \left( -\frac{n\pi a}{L} \alpha_n \sin \frac{n\pi at}{L} + \beta_n \cos \frac{n\pi at}{L} \right) \sin \frac{n\pi x}{L},$$

so

$$v_n(x, 0) = \alpha_n \sin \frac{n\pi x}{L} \quad \text{and} \quad \frac{\partial v_n}{\partial t}(x, 0) = \beta_n \sin \frac{n\pi x}{L}.$$

Therefore  $v_n$  satisfies (12.2.1) with  $f(x) = \alpha_n \sin n\pi x/L$  and  $g(x) = \beta_n \cos n\pi x/L$ . More generally, if  $\alpha_1, \alpha_2, \dots, \alpha_m$  and  $\beta_1, \beta_2, \dots, \beta_m$  are constants and

$$u_m(x, t) = \sum_{n=1}^m \left( \alpha_n \cos \frac{n\pi at}{L} + \frac{\beta_n L}{n\pi a} \sin \frac{n\pi at}{L} \right) \sin \frac{n\pi x}{L},$$

then  $u_m$  satisfies (12.2.1) with

$$f(x) = \sum_{n=1}^m \alpha_n \sin \frac{n\pi x}{L} \quad \text{and} \quad g(x) = \sum_{n=1}^m \beta_n \sin \frac{n\pi x}{L}.$$

This motivates the next definition.

**Definition 12.2.1** If  $f$  and  $g$  are piecewise smooth of  $[0, L]$ , then the formal solution of (12.2.1) is

$$u(x, t) = \sum_{n=1}^{\infty} \left( \alpha_n \cos \frac{n\pi at}{L} + \frac{\beta_n L}{n\pi a} \sin \frac{n\pi at}{L} \right) \sin \frac{n\pi x}{L}, \quad (12.2.8)$$

where

$$S_f(x) = \sum_{n=1}^{\infty} \alpha_n \sin \frac{n\pi x}{L} \quad \text{and} \quad S_g(x) = \sum_{n=1}^{\infty} \beta_n \sin \frac{n\pi x}{L}$$

are the Fourier sine series of  $f$  and  $g$  on  $[0, L]$ ; that is,

$$\alpha_n = \frac{2}{L} \int_0^L f(x) \sin \frac{n\pi x}{L} dx \quad \text{and} \quad \beta_n = \frac{2}{L} \int_0^L g(x) \sin \frac{n\pi x}{L} dx.$$

Since there are no convergence-producing factors in (12.2.8) like the negative exponentials in  $t$  that appear in formal solutions of initial-boundary value problems for the heat equation, it isn't obvious that (12.2.8) even converges for any values of  $x$  and  $t$ , let alone that it can be differentiated term by term to show that  $u_{tt} = a^2 u_{xx}$ . However, the next theorem guarantees that the series converges not only for  $0 \leq x \leq L$  and  $t \geq 0$ , but for  $-\infty < x < \infty$  and  $-\infty < t < \infty$ .

**Theorem 12.2.2** If  $f$  and  $g$  are piecewise smooth on  $[0, L]$ , then  $u$  in (12.2.1) converges for all  $(x, t)$ , and can be written as

$$u(x, t) = \frac{1}{2}[S_f(x+at) + S_f(x-at)] + \frac{1}{2a} \int_{x-at}^{x+at} S_g(\tau) d\tau. \quad (12.2.9)$$

**Proof** Setting  $A = n\pi x/L$  and  $B = n\pi at/L$  in the identities

$$\sin A \cos B = \frac{1}{2}[\sin(A+B) + \sin(A-B)]$$

and

$$\sin A \sin B = -\frac{1}{2}[\cos(A+B) - \cos(A-B)]$$

yields

$$\cos \frac{n\pi at}{L} \sin \frac{n\pi x}{L} = \frac{1}{2} \left[ \sin \frac{n\pi(x+at)}{L} + \sin \frac{n\pi(x-at)}{L} \right] \quad (12.2.10)$$

and

$$\begin{aligned} \sin \frac{n\pi at}{L} \sin \frac{n\pi x}{L} &= -\frac{1}{2} \left[ \cos \frac{n\pi(x+at)}{L} - \cos \frac{n\pi(x-at)}{L} \right] \\ &= \frac{n\pi}{2L} \int_{x-at}^{x+at} \sin \frac{n\pi\tau}{L} d\tau. \end{aligned} \quad (12.2.11)$$

From (12.2.10),

$$\begin{aligned} \sum_{n=1}^{\infty} \alpha_n \cos \frac{n\pi at}{L} \sin \frac{n\pi x}{L} &= \frac{1}{2} \sum_{n=1}^{\infty} \alpha_n \left( \sin \frac{n\pi(x+at)}{L} + \sin \frac{n\pi(x-at)}{L} \right) \\ &= \frac{1}{2} [S_f(x+at) + S_f(x-at)]. \end{aligned} \quad (12.2.12)$$

Since it can be shown that a Fourier sine series can be integrated term by term between any two limits, (12.2.11) implies that

$$\begin{aligned} \sum_{n=1}^{\infty} \frac{\beta_n L}{n\pi a} \sin \frac{n\pi at}{L} \sin \frac{n\pi x}{L} &= \frac{1}{2a} \sum_{n=1}^{\infty} \beta_n \int_{x-at}^{x+at} \sin \frac{n\pi\tau}{L} d\tau \\ &= \frac{1}{2a} \int_{x-at}^{x+at} \left( \sum_{n=1}^{\infty} \beta_n \sin \frac{n\pi\tau}{L} \right) d\tau \\ &= \frac{1}{2a} \int_{x-at}^{x+at} S_g(\tau) d\tau. \end{aligned}$$

This and (12.2.12) imply (12.2.9), which completes the proof.

As we'll see below, if  $S_g$  is differentiable and  $S_f$  is twice differentiable on  $(-\infty, \infty)$ , then (12.2.9) satisfies  $u_{tt} = a^2 u_{xx}$  for all  $(x, t)$ . We need the next theorem to formulate conditions on  $f$  and  $g$  such that  $S_f$  and  $S_g$  to have these properties.

**Theorem 12.2.3** *Suppose  $h$  is differentiable on  $[0, L]$ ; that is,  $h'(x)$  exists for  $0 < x < L$ , and the one-sided derivatives*

$$h'_+(0) = \lim_{x \rightarrow 0^+} \frac{h(x) - h(0)}{x} \quad \text{and} \quad h'_-(L) = \lim_{x \rightarrow L^-} \frac{h(x) - h(L)}{x - L}$$

*both exist.*

(a) *Let  $p$  be the odd periodic extension of  $h$  to  $(-\infty, \infty)$ ; that is,*

$$p(x) = \begin{cases} h(x), & 0 \leq x \leq L, \\ -h(-x), & -L < x < 0, \end{cases} \quad \text{and } p(x+2L) = p(x), \quad -\infty < x < \infty.$$

*Then  $p$  is differentiable on  $(-\infty, \infty)$  if and only if*

$$h(0) = h(L) = 0. \quad (12.2.13)$$

(b) *Let  $q$  be the even periodic extension of  $h$  to  $(-\infty, \infty)$ ; that is,*

$$q(x) = \begin{cases} h(x), & 0 \leq x \leq L, \\ h(-x), & -L < x < 0, \end{cases} \quad \text{and } q(x+2L) = q(x), \quad -\infty < x < \infty.$$

*Then  $q$  is differentiable on  $(-\infty, \infty)$  if and only if*

$$h'_+(0) = h'_-(L) = 0. \quad (12.2.14)$$

**Proof** Throughout this proof,  $k$  denotes an integer. Since  $f$  is differentiable on the open interval  $(0, L)$ , both  $p$  and  $q$  are differentiable on every open interval  $((k - 1)L, kL)$ . Thus, we need only to determine whether  $p$  and  $q$  are differentiable at  $x = kL$  for every  $k$ .

(a) From Figure 12.2.3,  $p$  is discontinuous at  $x = 2kL$  if  $h(0) \neq 0$  and discontinuous at  $x = (2k - 1)L$  if  $h(L) \neq 0$ . Therefore  $p$  is not differentiable on  $(-\infty, \infty)$  unless  $h(0) = h(L) = 0$ . From Figure 12.2.4, if  $h(0) = h(L) = 0$ , then

$$p'(2kL) = h'_+(0) \quad \text{and} \quad p'((2k - 1)L) = h'_-(L)$$

for every  $k$ ; therefore,  $p$  is differentiable on  $(-\infty, \infty)$ .

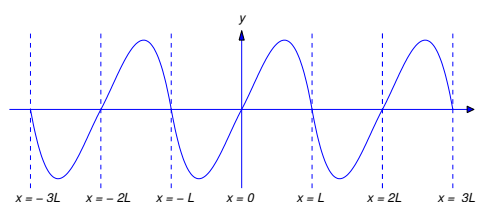
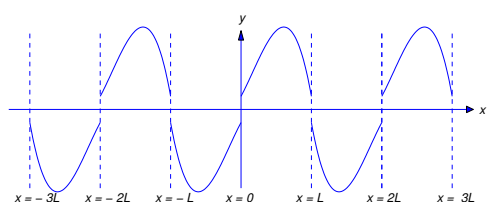

Figure 12.2.3 The odd extension of a function that does not satisfy (12.2.13)

Figure 12.2.4 The odd extension of a function that satisfies (12.2.13)

(b) From Figure 12.2.5,

$$q'_-(2kL) = -h'_+(0) \quad \text{and} \quad q'_+(2kL) = h'_+(0),$$

so  $q$  is differentiable at  $x = 2kL$  if and only if  $h'_+(0) = 0$ . Also,

$$q'_-((2k - 1)L) = h'_-(L) \quad \text{and} \quad q'_+((2k - 1)L) = -h'_-(L),$$

so  $q$  is differentiable at  $x = (2k - 1)L$  if and only if  $h'_-(L) = 0$ . Therefore  $q$  is differentiable on  $(-\infty, \infty)$  if and only if  $h'_+(0) = h'_-(L) = 0$ , as in Figure 12.2.6. This completes the proof.

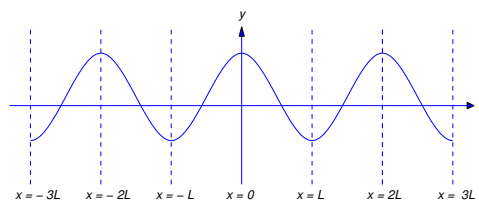
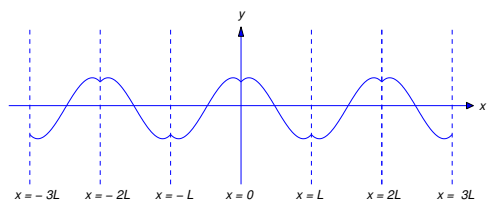

Figure 12.2.5 The even extension of a function that doesn't satisfy (12.2.14)

Figure 12.2.6 The even extension of a function that satisfies (12.2.14)

**Theorem 12.2.4** *The formal solution of (12.2.1) is an actual solution if  $g$  is differentiable on  $[0, L]$  and*

$$g(0) = g(L) = 0, \quad (12.2.15)$$

*while  $f$  is twice differentiable on  $[0, L]$  and*

$$f(0) = f(L) = 0 \quad (12.2.16)$$

*and*

$$f'_+(0) = f'_-(L) = 0. \quad (12.2.17)$$

**Proof** We first show that  $S_g$  is differentiable and  $S_f$  is twice differentiable on  $(-\infty, \infty)$ . We'll then differentiate (12.2.9) twice with respect to  $x$  and  $t$  and verify that (12.2.9) is an actual solution of (12.2.1).

Since  $f$  and  $g$  are continuous on  $(0, L)$ , Theorem 11.3.2 implies that  $S_f(x) = f(x)$  and  $S_g(x) = g(x)$  on  $[0, L]$ . Therefore  $S_f$  and  $S_g$  are the odd periodic extensions of  $f$  and  $g$ . Since  $f$  and  $g$  are differentiable on  $[0, L]$ , (12.2.15), (12.2.16), and Theorem 12.2.3(a) imply that  $S_f$  and  $S_g$  are differentiable on  $(-\infty, \infty)$ .

Since  $S'_f(x) = f'(x)$  on  $[0, L]$  (one-sided derivatives at the endpoints), and  $S'_f$  is even (the derivative of an odd function is even),  $S'_f$  is the even periodic extension of  $f'$ . By assumption,  $f'$  is differentiable on  $[0, L]$ . Because of (12.2.17), Theorem 12.2.3(b) with  $h = f'$  and  $q = S'_f$  implies that  $S''_f$  exists on  $(-\infty, \infty)$ .

Now we can differentiate (12.2.9) twice with respect to  $x$  and  $t$ :

$$u_x(x, t) = \frac{1}{2}[S'_f(x+at) + S'_f(x-at)] + \frac{1}{2a}[S_g(x+at) - S_g(x-at)],$$

$$u_{xx}(x, t) = \frac{1}{2}[S''_f(x+at) + S''_f(x-at)] + \frac{1}{2a}[S'_g(x+at) - S'_g(x-at)], \quad (12.2.18)$$

$$u_t(x, t) = \frac{a}{2}[S'_f(x+at) - S'_f(x-at)] + \frac{1}{2}[S_g(x+at) + S_g(x-at)], \quad (12.2.19)$$

and

$$u_{tt}(x, t) = \frac{a^2}{2}[S''_f(x+at) - S''_f(x-at)] + \frac{a}{2}[S'_g(x+at) - S'_g(x-at)]. \quad (12.2.20)$$

Comparing (12.2.18) and (12.2.20) shows that  $u_{tt}(x, t) = a^2 u_{xx}(x, t)$  for all  $(x, t)$ .

From (12.2.8),  $u(0, t) = u(L, t) = 0$  for all  $t$ . From (12.2.9),  $u(x, 0) = S_f(x)$  for all  $x$ , and therefore, in particular,

$$u(x, 0) = f(x), \quad 0 \leq x < L.$$

From (12.2.19),  $u_t(x, 0) = S_g(x)$  for all  $x$ , and therefore, in particular,

$$u_t(x, 0) = g(x), \quad 0 \leq x < L.$$

Therefore  $u$  is an actual solution of (12.2.1). This completes the proof.

Eqn (12.2.9) is called *d'Alembert's solution* of (12.2.1). Although d'Alembert's solution was useful for proving Theorem 12.2.4 and is very useful in a slightly different context (Exercises 63-68), (12.2.8) is preferable for computational purposes.

**Example 12.2.1** Solve (12.2.1) with

$$f(x) = x(x^3 - 2Lx^2 + L^2) \quad \text{and} \quad g(x) = x(L - x).$$

**Solution** We leave it to you to verify that  $f$  and  $g$  satisfy the assumptions of Theorem 12.2.4.

From Exercise 11.3.39,

$$S_f(x) = \frac{96L^4}{\pi^5} \sum_{n=1}^{\infty} \frac{1}{(2n-1)^5} \sin \frac{(2n-1)\pi x}{L}.$$

From Exercise 11.3.36,

$$S_g(x) = \frac{8L^2}{\pi^3} \sum_{n=1}^{\infty} \frac{1}{(2n-1)^3} \sin \frac{(2n-1)\pi x}{L}.$$

From (12.2.8),

$$\begin{aligned} u(x, t) &= \frac{96L^4}{\pi^5} \sum_{n=1}^{\infty} \frac{1}{(2n-1)^5} \cos \frac{(2n-1)\pi at}{L} \sin \frac{(2n-1)\pi x}{L} \\ &\quad + \frac{8L^3}{a\pi^4} \sum_{n=1}^{\infty} \frac{1}{(2n-1)^4} \sin \frac{(2n-1)\pi at}{L} \sin \frac{(2n-1)\pi x}{L}. \end{aligned}$$

Theorem 12.1.2 implies that  $u_{xx}$  and  $u_{tt}$  can be obtained by term by term differentiation, for all  $(x, t)$ , so  $u_{tt} = a^2 u_{xx}$  for all  $(x, t)$  (Exercise 62). Moreover, Theorem 11.3.2 implies that  $S_f(x) = f(x)$  and  $S_g(x) = g(x)$  if  $0 \leq x \leq L$ . Therefore  $u(x, 0) = f(x)$  and  $u_t(x, 0) = g(x)$  if  $0 \leq x \leq L$ . Hence,  $u$  is an actual solution of the initial-boundary value problem.

**REMARK:** In solving a specific initial-boundary value problem (12.2.1), it's convenient to solve the problem with  $g \equiv 0$ , then with  $f \equiv 0$ , and add the solutions to obtain the solution of the given problem. Because of this, either  $f \equiv 0$  or  $g \equiv 0$  in all the specific initial-boundary value problems in the exercises.

### The Plucked String

If  $f$  and  $g$  don't satisfy the assumptions of Theorem 12.2.4, then (12.2.8) isn't an actual solution of (12.2.1) in fact, it can be shown that (12.2.1) doesn't have an actual solution in this case. Nevertheless,  $u$  is defined for all  $(x, t)$ , and we can see from (12.2.18) and (12.2.20) that  $u_{tt}(x, t) = a^2 u_{xx}(x, t)$  for all  $(x, t)$  such that  $S_f''(x \pm at)$  and  $S_g'(x \pm at)$  exist. Moreover,  $u$  may still provide a useful approximation to the vibration of the string; a laboratory experiment can confirm or deny this.

We'll now consider the initial-boundary value problem (12.2.1) with

$$f(x) = \begin{cases} x, & 0 \leq x \leq \frac{L}{2}, \\ L - x, & \frac{L}{2} \leq x \leq L \end{cases} \quad (12.2.21)$$

and  $g \equiv 0$ . Since  $f$  isn't differentiable at  $x = L/2$ , it doesn't satisfy the assumptions of Theorem 12.2.4, so the formal solution of (12.2.1) can't be an actual solution. Nevertheless, it's instructive to investigate the properties of the formal solution.

The graph of  $f$  is shown in Figure 12.2.7. Intuitively, we are plucking the string by half its length at the middle. You're right if you think this is an extraordinarily large displacement; however, we could remove this objection by multiplying the function in Figure 12.2.7 by a small constant. Since this would just multiply the formal solution by the same constant, we'll leave  $f$  as we've defined it. Similar comments apply to the exercises.

From Exercise 11.3.15, the Fourier sine series of  $f$  on  $[0, L]$  is

$$S_f(x) = \frac{4L}{\pi^2} \sum_{n=1}^{\infty} \frac{(-1)^{n+1}}{(2n-1)^2} \sin \frac{(2n-1)\pi x}{L},$$

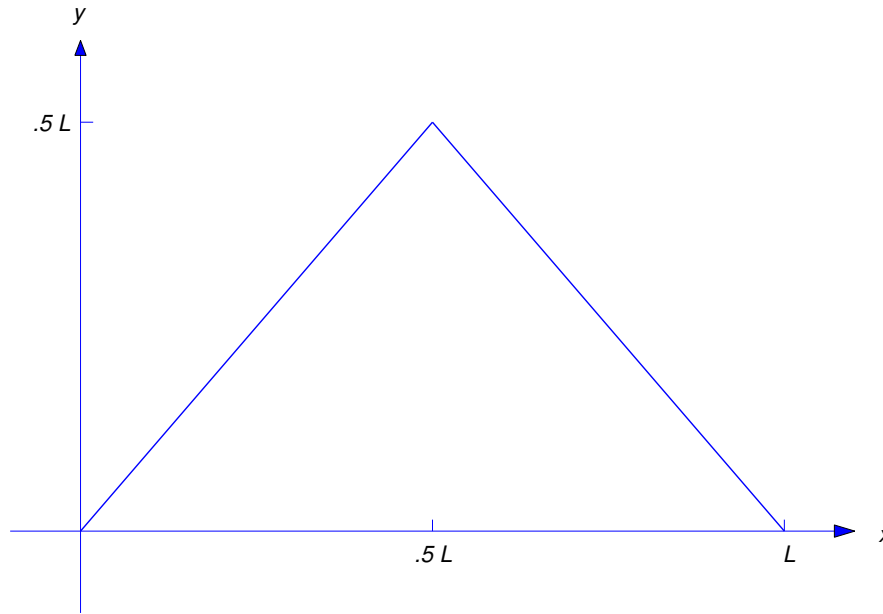

Figure 12.2.7 Graph of (12.2.21)

which converges to  $f$  for all  $x$  in  $[0, L]$ , by Theorem 11.3.2. Therefore

$$u(x, t) = \frac{4L}{\pi^2} \sum_{n=1}^{\infty} \frac{(-1)^{n+1}}{(2n-1)^2} \cos \frac{(2n-1)\pi at}{L} \sin \frac{(2n-1)\pi x}{L}. \quad (12.2.22)$$

This series converges absolutely for all  $(x, t)$  by the comparison test, since the series

$$\sum_{n=1}^{\infty} \frac{1}{(2n-1)^2}$$

converges. Moreover, (12.2.22) satisfies the boundary conditions

$$u(0, t) = u(L, t) = 0, \quad t > 0,$$

and the initial condition

$$u(x, 0) = f(x), \quad 0 \leq x \leq L.$$

However, we can't justify differentiating (12.2.22) term by term even once, and formally differentiating it twice term by term produces a series that diverges for all  $(x, t)$ . (Verify.). Therefore we use d'Alembert's form

$$u(x, t) = \frac{1}{2}[S_f(x+at) + S_f(x-at)] \quad (12.2.23)$$

for  $u$  to study its derivatives. Figure 12.2.8 shows the graph of  $S_f$ , which is the odd periodic extension of  $f$ . You can see from the graph that  $S_f$  is differentiable at  $x$  (and  $S'_f(x) = \pm 1$ ) if and only if  $x$  isn't an odd multiple of  $L/2$ .

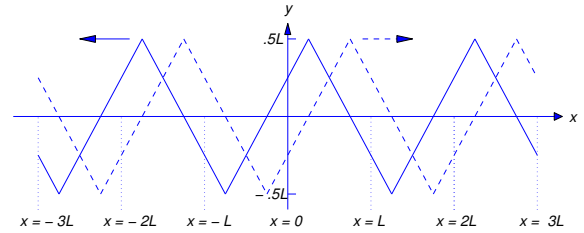
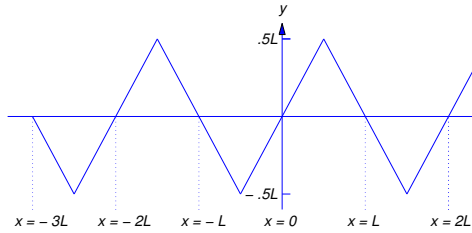

Figure 12.2.8 The odd periodic extension of (12.2.21)

Figure 12.2.9 Graphs of  $y = S_f(x - at)$  (dashed) and  $y = S_f(x + at)$  (solid), with  $f$  as in (12.2.21)

In Figure 12.2.9 the dashed and solid curves are the graphs of  $y = S_f(x - at)$  and  $y = S_f(x + at)$  respectively, for a fixed value of  $t$ . As  $t$  increases the dashed curve moves to the right and the solid curve moves to the left. For this reason, we say that the functions  $u_1(x, t) = S_f(x + at)$  and  $u_2(x, t) = S_f(x - at)$  are *traveling waves*. Note that  $u_1$  satisfies the wave equation at  $(x, t)$  if  $x + at$  isn't an odd multiple of  $L/2$  and  $u_2$  satisfies the wave equation at  $(x, t)$  if  $x - at$  isn't an odd multiple of  $L/2$ . Therefore (12.2.23) (or, equivalently, (12.2.22)) satisfies  $u_{tt}(x, t) = a^2 u_{xx}(x, t) = 0$  for all  $(x, t)$  such that neither  $x - at$  nor  $x + at$  is an odd multiple of  $L/2$ .

We conclude by finding an explicit formula for  $u(x, t)$  under the assumption that

$$0 \leq x \leq L \quad \text{and} \quad 0 \leq t \leq L/2a. \tag{12.2.24}$$

To see how this formula can be used to compute  $u(x, t)$  for  $0 \leq x \leq L$  and arbitrary  $t$ , we refer you to Exercise 16.

From Figure 12.2.10,

$$S_f(x - at) = \begin{cases} x - at, & 0 \leq x \leq \frac{L}{2} + at, \\ L - x + at, & \frac{L}{2} + at \leq x \leq L \end{cases}$$

and

$$S_f(x + at) = \begin{cases} x + at, & 0 \leq x \leq \frac{L}{2} - at, \\ L - x - at, & \frac{L}{2} - at \leq x \leq L \end{cases}$$

if  $(x, t)$  satisfies (12.2.24).

Therefore, from (12.2.23),

$$u(x, t) = \begin{cases} x, & 0 \leq x \leq \frac{L}{2} - at, \\ \frac{L}{2} - at, & \frac{L}{2} - at \leq x \leq \frac{L}{2} + at, \\ L - x, & \frac{L}{2} + at \leq x \leq L \end{cases}$$

if  $(x, t)$  satisfies (12.2.24). Figure 12.2.11 is the graph of this function on  $[0, L]$  for a fixed  $t$  in  $(0, L/2a)$ .

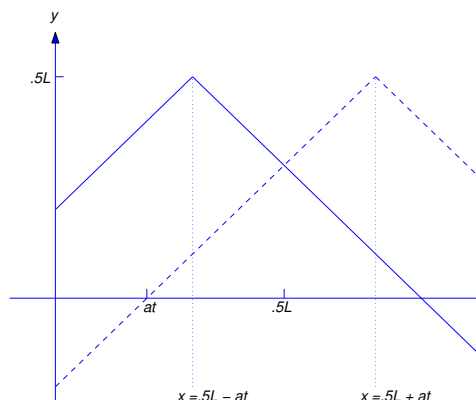
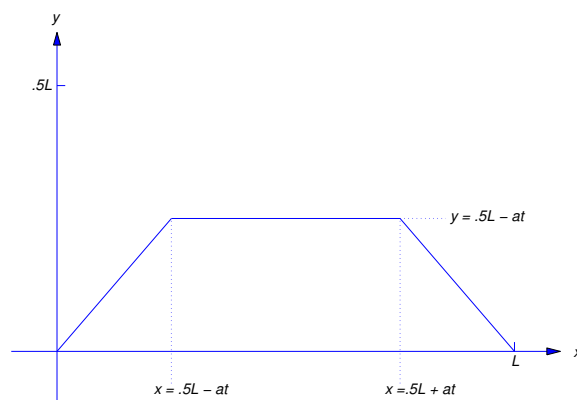
Figure 12.2.10 The part of the graph from Figure 12.2.9 on  $[0, L]$ Figure 12.2.11 The graph of (12.2.23) on  $[0, L]$  for a fixed  $t$  in  $(0, L/2a)$ **USING TECHNOLOGY**

Although the formal solution

$$u(x, t) = \sum_{n=1}^{\infty} \left( \alpha_n \cos \frac{n\pi at}{L} + \frac{\beta_n L}{n\pi a} \sin \frac{n\pi at}{L} \right) \sin \frac{n\pi x}{L}$$

of (12.2.1) is defined for all  $(x, t)$ , we're mainly interested in its behavior for  $0 \leq x \leq L$  and  $t \geq 0$ . In fact, it's sufficient to consider only values of  $t$  in the interval  $0 \leq t < 2L/a$ , since

$$u(x, t + 2kL/a) = u(x, t)$$

for all  $(x, t)$  if  $k$  is an integer. (Verify.)

You can create an animation of the motion of the string by performing the following numerical experiment.

Let  $m$  and  $k$  be positive integers. Let

$$t_j = \frac{2Lj}{ka}, \quad j = 0, 1, \dots, k;$$

thus,  $t_0, t_1, \dots, t_k$  are equally spaced points in  $[0, 2L/a]$ . For each  $j = 0, 1, 2, \dots, k$ , graph the partial sum

$$u_m(x, t_j) = \sum_{n=1}^m \left( \alpha_n \cos \frac{n\pi at_j}{L} + \frac{\beta_n L}{n\pi a} \sin \frac{n\pi at_j}{L} \right) \sin \frac{n\pi x}{L}$$

on  $[0, L]$  as a function of  $x$ . Write your program so that each graph remains displayed on the monitor for a short time, and is then deleted and replaced by the next. Repeat this procedure for various values of  $m$  and  $k$ .

We suggest that you perform experiments of this kind in the exercises marked **C**, without other specific instructions. (These exercises were chosen arbitrarily; the experiment is worthwhile in all the exercises dealing with specific initial-boundary value problems.) In some of the exercises the formal solutions have other forms, defined in Exercises 17, 34, and 49; however, the idea of the experiment is the same.



## 12.2 Exercises

In Exercises 1-15 solve the initial-boundary value problem. In some of these exercises, Theorem 11.3.5(b) or Exercise 11.3.35 will simplify the computation of the coefficients in the Fourier sine series.

1.  $u_{tt} = 9u_{xx}$ ,  $0 < x < 1$ ,  $t > 0$ ,  
 $u(0, t) = 0$ ,  $u(1, t) = 0$ ,  $t > 0$ ,  
 $u(x, 0) = 0$ ,  $u_t(x, 0) = \begin{cases} x, & 0 \leq x \leq \frac{1}{2}, \\ 1 - x, & \frac{1}{2} \leq x \leq 1 \end{cases}$ ,  $0 \leq x \leq 1$
2.  $u_{tt} = 9u_{xx}$ ,  $0 < x < 1$ ,  $t > 0$ ,  
 $u(0, t) = 0$ ,  $u(1, t) = 0$ ,  $t > 0$ ,  
 $u(x, 0) = x(1 - x)$ ,  $u_t(x, 0) = 0$ ,  $0 \leq x \leq 1$
3.  $u_{tt} = 7u_{xx}$ ,  $0 < x < 1$ ,  $t > 0$ ,  
 $u(0, t) = 0$ ,  $u(1, t) = 0$ ,  $t > 0$ ,  
 $u(x, 0) = x^2(1 - x)$ ,  $u_t(x, 0) = 0$ ,  $0 \leq x \leq 1$
4.  $\boxed{C}$   $u_{tt} = 9u_{xx}$ ,  $0 < x < 1$ ,  $t > 0$ ,  
 $u(0, t) = 0$ ,  $u(1, t) = 0$ ,  $t > 0$ ,  
 $u(x, 0) = 0$ ,  $u_t(x, 0) = x(1 - x)$ ,  $0 \leq x \leq 1$
5.  $u_{tt} = 7u_{xx}$ ,  $0 < x < 1$ ,  $t > 0$ ,  
 $u(0, t) = 0$ ,  $u(1, t) = 0$ ,  $t > 0$ ,  
 $u(x, 0) = 0$ ,  $u_t(x, 0) = x^2(1 - x)$ ,  $0 \leq x \leq 1$
6.  $u_{tt} = 64u_{xx}$ ,  $0 < x < 3$ ,  $t > 0$ ,  
 $u(0, t) = 0$ ,  $u(3, t) = 0$ ,  $t > 0$ ,  
 $u(x, 0) = x(x^2 - 9)$ ,  $u_t(x, 0) = 0$ ,  $0 \leq x \leq 3$
7.  $u_{tt} = 4u_{xx}$ ,  $0 < x < 1$ ,  $t > 0$ ,  
 $u(0, t) = 0$ ,  $u(1, t) = 0$ ,  $t > 0$ ,  
 $u(x, 0) = x(x^3 - 2x^2 + 1)$ ,  $u_t(x, 0) = 0$ ,  $0 \leq x \leq 1$
8.  $\boxed{C}$   $u_{tt} = 64u_{xx}$ ,  $0 < x < 3$ ,  $t > 0$ ,  
 $u(0, t) = 0$ ,  $u(3, t) = 0$ ,  $t > 0$ ,  
 $u(x, 0) = 0$ ,  $u_t(x, 0) = x(x^2 - 9)$ ,  $0 \leq x \leq 3$
9.  $u_{tt} = 4u_{xx}$ ,  $0 < x < 1$ ,  $t > 0$ ,  
 $u(0, t) = 0$ ,  $u(1, t) = 0$ ,  $t > 0$ ,  
 $u(x, 0) = 0$ ,  $u_t(x, 0) = x(x^3 - 2x^2 + 1)$ ,  $0 \leq x \leq 1$
10.  $u_{tt} = 5u_{xx}$ ,  $0 < x < \pi$ ,  $t > 0$ ,  
 $u(0, t) = 0$ ,  $u(\pi, t) = 0$ ,  $t > 0$ ,  
 $u(x, 0) = x \sin x$ ,  $u_t(x, 0) = 0$ ,  $0 \leq x \leq \pi$
11.  $u_{tt} = u_{xx}$ ,  $0 < x < 1$ ,  $t > 0$ ,  
 $u(0, t) = 0$ ,  $u(1, t) = 0$ ,  $t > 0$ ,  
 $u(x, 0) = x(3x^4 - 5x^3 + 2)$ ,  $u_t(x, 0) = 0$ ,  $0 \leq x \leq 1$
12.  $\boxed{C}$   $u_{tt} = 5u_{xx}$ ,  $0 < x < \pi$ ,  $t > 0$ ,  
 $u(0, t) = 0$ ,  $u(\pi, t) = 0$ ,  $t > 0$ ,  
 $u(x, 0) = 0$ ,  $u_t(x, 0) = x \sin x$ ,  $0 \leq x \leq \pi$
13.  $u_{tt} = u_{xx}$ ,  $0 < x < 1$ ,  $t > 0$ ,  
 $u(0, t) = 0$ ,  $u(1, t) = 0$ ,  $t > 0$ ,  
 $u(x, 0) = 0$ ,  $u_t(x, 0) = x(3x^4 - 5x^3 + 2)$ ,  $0 \leq x \leq 1$

14.  $u_{tt} = 9u_{xx}$ ,  $0 < x < 1$ ,  $t > 0$ ,  
 $u(0, t) = 0$ ,  $u(1, t) = 0$ ,  $t > 0$ ,  
 $u(x, 0) = x(3x^4 - 10x^2 + 7)$ ,  $u_t(x, 0) = 0$ ,  $0 \leq x \leq 1$

15. **C**  $u_{tt} = 9u_{xx}$ ,  $0 < x < 1$ ,  $t > 0$ ,  
 $u(0, t) = 0$ ,  $u(1, t) = 0$ ,  $t > 0$ ,  
 $u(x, 0) = 0$ ,  $u_t(x, 0) = x(3x^4 - 10x^2 + 7)$ ,  $0 \leq x \leq 1$

16. We saw that the displacement of the plucked string is, on the one hand,

$$u(x, t) = \frac{4L}{\pi^2} \sum_{n=1}^{\infty} \frac{(-1)^{n+1}}{(2n-1)^2} \cos \frac{(2n-1)\pi at}{L} \sin \frac{(2n-1)\pi x}{L}, \quad 0 \leq x \leq L, \quad t \geq 0, \quad (\text{A})$$

and, on the other hand,

$$u(x, \tau) = \begin{cases} x, & 0 \leq x \leq \frac{L}{2} - a\tau, \\ \frac{L}{2} - a\tau, & \frac{L}{2} - a\tau \leq x \leq \frac{L}{2} + a\tau, \\ L - x, & \frac{L}{2} + a\tau \leq x \leq L. \end{cases} \quad (\text{B})$$

if  $0 \leq \tau \leq L/2a$ . The first objective of this exercise is to show that (B) can be used to compute  $u(x, t)$  for  $0 \leq x \leq L$  and all  $t > 0$ .

(a) Show that if  $t > 0$ , there's a nonnegative integer  $m$  such that either

$$\text{(i)} \quad t = \frac{mL}{a} + \tau \quad \text{or} \quad \text{(ii)} \quad t = \frac{(m+1)L}{a} - \tau,$$

where  $0 \leq \tau \leq L/2a$ .

(b) Use (A) to show that  $u(x, t) = (-1)^m u(x, \tau)$  if (i) holds, while  $u(x, t) = (-1)^{m+1} u(x, \tau)$  if (ii) holds.

(c) **L** Perform the following experiment for specific values of  $L$  and  $a$  and various values of  $m$  and  $k$ : Let

$$t_j = \frac{Lj}{2ka}, \quad j = 0, 1, \dots, k;$$

thus,  $t_0, t_1, \dots, t_k$  are equally spaced points in  $[0, L/2a]$ . For each  $j = 0, 1, 2, \dots, k$ , graph the  $m$ th partial sum of (A) and  $u(x, t_j)$  computed from (B) on the same axis. Create an animation, as described in the remarks on using technology at the end of the section.

17. If a string vibrates with the end at  $x = 0$  free to move in a frictionless vertical track and the end at  $x = L$  fixed, then the initial-boundary value problem for its displacement takes the form

$$\begin{aligned} u_{tt} &= a^2 u_{xx}, & 0 < x < L, & \quad t > 0, \\ u_x(0, t) &= 0, & u(L, t) &= 0, & \quad t > 0, \\ u(x, 0) &= f(x), & u_t(x, 0) &= g(x), & \quad 0 \leq x \leq L. \end{aligned} \quad (\text{A})$$

Justify defining the formal solution of (A) to be

$$u(x, t) = \sum_{n=1}^{\infty} \left( \alpha_n \cos \frac{(2n-1)\pi at}{2L} + \frac{2L\beta_n}{(2n-1)\pi a} \sin \frac{(2n-1)\pi at}{2L} \right) \cos \frac{(2n-1)\pi x}{2L},$$

where

$$C_{Mf}(x) = \sum_{n=1}^{\infty} \alpha_n \cos \frac{(2n-1)\pi x}{2L} \quad \text{and} \quad C_{Mg}(x) = \sum_{n=1}^{\infty} \beta_n \cos \frac{(2n-1)\pi x}{2L}$$

are the mixed Fourier cosine series of  $f$  and  $g$  on  $[0, L]$ ; that is,

$$\alpha_n = \frac{2}{L} \int_0^L f(x) \cos \frac{(2n-1)\pi x}{2L} dx \quad \text{and} \quad \beta_n = \frac{2}{L} \int_0^L g(x) \cos \frac{(2n-1)\pi x}{2L} dx.$$

In Exercises 18-31, use Exercise 17 to solve the initial-boundary value problem. In some of these exercises Theorem 11.3.5(c) or Exercise 11.3.42(b) will simplify the computation of the coefficients in the mixed Fourier cosine series.

18.  $u_{tt} = 9u_{xx}$ ,  $0 < x < 2$ ,  $t > 0$ ,  
 $u_x(0, t) = 0$ ,  $u(2, t) = 0$ ,  $t > 0$ ,  
 $u(x, 0) = 4 - x^2$ ,  $u_t(x, 0) = 0$ ,  $0 \leq x \leq 2$
19.  $u_{tt} = 4u_{xx}$ ,  $0 < x < 1$ ,  $t > 0$ ,  
 $u_x(0, t) = 0$ ,  $u(1, t) = 0$ ,  $t > 0$ ,  
 $u(x, 0) = x^2(1 - x)$ ,  $u_t(x, 0) = 0$ ,  $0 \leq x \leq 1$
20.  $u_{tt} = 9u_{xx}$ ,  $0 < x < 2$ ,  $t > 0$ ,  
 $u_x(0, t) = 0$ ,  $u(2, t) = 0$ ,  $t > 0$ ,  
 $u(x, 0) = 0$ ,  $u_t(x, 0) = 4 - x^2$ ,  $0 \leq x \leq 2$
21.  $u_{tt} = 4u_{xx}$ ,  $0 < x < 1$ ,  $t > 0$ ,  
 $u_x(0, t) = 0$ ,  $u(1, t) = 0$ ,  $t > 0$ ,  
 $u(x, 0) = 0$ ,  $u_t(x, 0) = x^2(1 - x)$ ,  $0 \leq x \leq 1$
22. C  $u_{tt} = 5u_{xx}$ ,  $0 < x < 1$ ,  $t > 0$ ,  
 $u_x(0, t) = 0$ ,  $u(1, t) = 0$ ,  $t > 0$ ,  
 $u(x, 0) = 2x^3 + 3x^2 - 5$ ,  $u_t(x, 0) = 0$ ,  $0 \leq x \leq 1$
23.  $u_{tt} = 3u_{xx}$ ,  $0 < x < \pi$ ,  $t > 0$ ,  
 $u_x(0, t) = 0$ ,  $u(\pi, t) = 0$ ,  $t > 0$ ,  
 $u(x, 0) = \pi^3 - x^3$ ,  $u_t(x, 0) = 0$ ,  $0 \leq x \leq \pi$
24.  $u_{tt} = 5u_{xx}$ ,  $0 < x < 1$ ,  $t > 0$ ,  
 $u_x(0, t) = 0$ ,  $u(1, t) = 0$ ,  $t > 0$ ,  
 $u(x, 0) = 0$ ,  $u_t(x, 0) = 2x^3 + 3x^2 - 5$ ,  $0 \leq x \leq 1$
25. C  $u_{tt} = 3u_{xx}$ ,  $0 < x < \pi$ ,  $t > 0$ ,  
 $u_x(0, t) = 0$ ,  $u(\pi, t) = 0$ ,  $t > 0$ ,  
 $u(x, 0) = 0$ ,  $u_t(x, 0) = \pi^3 - x^3$ ,  $0 \leq x \leq \pi$
26.  $u_{tt} = 9u_{xx}$ ,  $0 < x < 1$ ,  $t > 0$ ,  
 $u_x(0, t) = 0$ ,  $u(1, t) = 0$ ,  $t > 0$ ,  
 $u(x, 0) = x^4 - 2x^3 + 1$ ,  $u_t(x, 0) = 0$ ,  $0 \leq x \leq 1$
27.  $u_{tt} = 7u_{xx}$ ,  $0 < x < 1$ ,  $t > 0$ ,  
 $u_x(0, t) = 0$ ,  $u(1, t) = 0$ ,  $t > 0$ ,  
 $u(x, 0) = 4x^3 + 3x^2 - 7$ ,  $u_t(x, 0) = 0$ ,  $0 \leq x \leq 1$
28.  $u_{tt} = 9u_{xx}$ ,  $0 < x < 1$ ,  $t > 0$ ,  
 $u_x(0, t) = 0$ ,  $u(1, t) = 0$ ,  $t > 0$ ,  
 $u(x, 0) = 0$ ,  $u_t(x, 0) = x^4 - 2x^3 + 1$ ,  $0 \leq x \leq 1$
29. C  $u_{tt} = 7u_{xx}$ ,  $0 < x < 1$ ,  $t > 0$ ,  
 $u_x(0, t) = 0$ ,  $u(1, t) = 0$ ,  $t > 0$ ,  
 $u(x, 0) = 0$ ,  $u_t(x, 0) = 4x^3 + 3x^2 - 7$ ,  $0 \leq x \leq 1$

30.  $u_{tt} = u_{xx}$ ,  $0 < x < 1$ ,  $t > 0$ ,  
 $u_x(0, t) = 0$ ,  $u(1, t) = 0$ ,  $t > 0$ ,  
 $u(x, 0) = x^4 - 4x^3 + 6x^2 - 3$ ,  $u_t(x, 0) = 0$ ,  $0 \leq x \leq 1$
31.  $u_{tt} = u_{xx}$ ,  $0 < x < 1$ ,  $t > 0$ ,  
 $u_x(0, t) = 0$ ,  $u(1, t) = 0$ ,  $t > 0$ ,  
 $u(x, 0) = 0$ ,  $u_t(x, 0) = x^4 - 4x^3 + 6x^2 - 3$ ,  $0 \leq x \leq 1$
32. Adapt the proof of Theorem 12.2.2 to find d'Alembert's solution of the initial-boundary value problem in Exercise 17.
33. Use the result of Exercise 32 to show that the formal solution of the initial-boundary value problem in Exercise 17 is an actual solution if  $g$  is differentiable and  $f$  is twice differentiable on  $[0, L]$  and

$$g'_+(0) = g(L) = f'_+(0) = f(L) = f''_-(L) = 0.$$

HINT: See Exercise 11.3.57, and apply Theorem 12.2.3 with  $L$  replaced by  $2L$ .

34. Justify defining the formal solution of the initial-boundary value problem

$$\begin{aligned} u_{tt} &= a^2 u_{xx}, & 0 < x < L, & \quad t > 0, \\ u(0, t) &= 0, & u_x(L, t) &= 0, & \quad t > 0, \\ u(x, 0) &= f(x), & u_t(x, 0) &= g(x), & \quad 0 \leq x \leq L \end{aligned}$$

to be

$$u(x, t) = \sum_{n=1}^{\infty} \left( \alpha_n \cos \frac{(2n-1)\pi at}{2L} + \frac{2L\beta_n}{(2n-1)\pi a} \sin \frac{(2n-1)\pi at}{2L} \right) \sin \frac{(2n-1)\pi x}{2L},$$

where

$$S_{Mf}(x) = \sum_{n=1}^{\infty} \alpha_n \sin \frac{(2n-1)\pi x}{2L} \quad \text{and} \quad S_{Mg}(x) = \sum_{n=1}^{\infty} \beta_n \sin \frac{(2n-1)\pi x}{2L}$$

are the mixed Fourier sine series of  $f$  and  $g$  on  $[0, L]$ ; that is,

$$\alpha_n = \frac{2}{L} \int_0^L f(x) \sin \frac{(2n-1)\pi x}{2L} dx \quad \text{and} \quad \beta_n = \frac{2}{L} \int_0^L g(x) \sin \frac{(2n-1)\pi x}{2L} dx.$$

In Exercises 35-46 use Exercise 34 to solve the initial-boundary value problem. In some of these exercises Theorem 11.3.5(d) or Exercise 11.3.50(b) will simplify the computation of the coefficients in the mixed Fourier sine series.

35.  $u_{tt} = 64u_{xx}$ ,  $0 < x < \pi$ ,  $t > 0$ ,  
 $u(0, t) = 0$ ,  $u_x(\pi, t) = 0$ ,  $t > 0$ ,  
 $u(x, 0) = x(2\pi - x)$ ,  $u_t(x, 0) = 0$ ,  $0 \leq x \leq \pi$
36.  $u_{tt} = 9u_{xx}$ ,  $0 < x < 1$ ,  $t > 0$ ,  
 $u(0, t) = 0$ ,  $u_x(1, t) = 0$ ,  $t > 0$ ,  
 $u(x, 0) = x^2(3 - 2x)$ ,  $u_t(x, 0) = 0$ ,  $0 \leq x \leq 1$
37.  $u_{tt} = 64u_{xx}$ ,  $0 < x < \pi$ ,  $t > 0$ ,  
 $u(0, t) = 0$ ,  $u_x(\pi, t) = 0$ ,  $t > 0$ ,  
 $u(x, 0) = 0$ ,  $u_t(x, 0) = x(2\pi - x)$ ,  $0 \leq x \leq \pi$

38.  $\square$   $u_{tt} = 9u_{xx}$ ,  $0 < x < 1$ ,  $t > 0$ ,  
 $u(0, t) = 0$ ,  $u_x(1, t) = 0$ ,  $t > 0$ ,  
 $u(x, 0) = 0$ ,  $u_t(x, 0) = x^2(3 - 2x)$ ,  $0 \leq x \leq 1$
39.  $u_{tt} = 9u_{xx}$ ,  $0 < x < 1$ ,  $t > 0$ ,  
 $u(0, t) = 0$ ,  $u_x(1, t) = 0$ ,  $t > 0$ ,  
 $u(x, 0) = (x - 1)^3 + 1$ ,  $u_t(x, 0) = 0$ ,  $0 \leq x \leq 1$
40.  $u_{tt} = 3u_{xx}$ ,  $0 < x < \pi$ ,  $t > 0$ ,  
 $u(0, t) = 0$ ,  $u_x(\pi, t) = 0$ ,  $t > 0$ ,  
 $u(x, 0) = x(x^2 - 3\pi^2)$ ,  $u_t(x, 0) = 0$ ,  $0 \leq x \leq \pi$
41.  $u_{tt} = 9u_{xx}$ ,  $0 < x < 1$ ,  $t > 0$ ,  
 $u(0, t) = 0$ ,  $u_x(1, t) = 0$ ,  $t > 0$ ,  
 $u(x, 0) = 0$ ,  $u_t(x, 0) = (x - 1)^3 + 1$ ,  $0 \leq x \leq 1$
42.  $u_{tt} = 3u_{xx}$ ,  $0 < x < \pi$ ,  $t > 0$ ,  
 $u(0, t) = 0$ ,  $u_x(\pi, t) = 0$ ,  $t > 0$ ,  
 $u(x, 0) = 0$ ,  $u_t(x, 0) = x(x^2 - 3\pi^2)$ ,  $0 \leq x \leq \pi$
43.  $u_{tt} = 5u_{xx}$ ,  $0 < x < 1$ ,  $t > 0$ ,  
 $u(0, t) = 0$ ,  $u_x(1, t) = 0$ ,  $t > 0$ ,  
 $u(x, 0) = x^3(3x - 4)$ ,  $u_t(x, 0) = 0$ ,  $0 \leq x \leq 1$
44.  $\square$   $u_{tt} = 16u_{xx}$ ,  $0 < x < 1$ ,  $t > 0$ ,  
 $u(0, t) = 0$ ,  $u_x(1, t) = 0$ ,  $t > 0$ ,  
 $u(x, 0) = x(x^3 - 2x^2 + 2)$ ,  $u_t(x, 0) = 0$ ,  $0 \leq x \leq 1$
45.  $u_{tt} = 5u_{xx}$ ,  $0 < x < 1$ ,  $t > 0$ ,  
 $u(0, t) = 0$ ,  $u_x(1, t) = 0$ ,  $t > 0$ ,  
 $u(x, 0) = 0$ ,  $u_t(x, 0) = x^3(3x - 4)$ ,  $0 \leq x \leq 1$
46.  $\square$   $u_{tt} = 16u_{xx}$ ,  $0 < x < 1$ ,  $t > 0$ ,  
 $u(0, t) = 0$ ,  $u_x(1, t) = 0$ ,  $t > 0$ ,  
 $u(x, 0) = 0$ ,  $u_t(x, 0) = x(x^3 - 2x^2 + 2)$ ,  $0 \leq x \leq 1$
47. Adapt the proof of Theorem 12.2.2 to find d'Alembert's solution of the initial-boundary value problem in Exercise 34.
48. Use the result of Exercise 47 to show that the formal solution of the initial-boundary value problem in Exercise 34 is an actual solution if  $g$  is differentiable and  $f$  is twice differentiable on  $[0, L]$  and

$$f(0) = f'_-(L) = g(0) = g'_-(L) = f''_+(0) = 0.$$

HINT: See Exercise 11.3.58 and apply Theorem 12.2.3 with  $L$  replaced by  $2L$ .

49. Justify defining the formal solution of the initial-boundary value problem

$$\begin{aligned} u_{tt} &= a^2 u_{xx}, & 0 < x < L, & \quad t > 0, \\ u_x(0, t) &= 0, & u_x(L, t) &= 0, & \quad t > 0, \\ u(x, 0) &= f(x), & u_t(x, 0) &= g(x), & \quad 0 \leq x \leq L. \end{aligned}$$

to be

$$u(x, t) = \alpha_0 + \beta_0 t + \sum_{n=1}^{\infty} \left( \alpha_n \cos \frac{n\pi at}{L} + \frac{L\beta_n}{n\pi a} \sin \frac{n\pi at}{L} \right) \cos \frac{n\pi x}{L},$$

where

$$C_f(x) = \alpha_0 + \sum_{n=1}^{\infty} \alpha_n \cos \frac{n\pi x}{L} \quad \text{and} \quad C_g(x) = \beta_0 + \sum_{n=1}^{\infty} \beta_n \cos \frac{n\pi x}{L}$$

are the Fourier cosine series of  $f$  and  $g$  on  $[0, L]$ ; that is,

$$\alpha_0 = \frac{1}{L} \int_0^L f(x) dx, \quad \beta_0 = \frac{1}{L} \int_0^L g(x) dx,$$

$$\alpha_n = \frac{2}{L} \int_0^L f(x) \cos \frac{n\pi x}{L} dx, \quad \text{and} \quad \beta_n = \frac{2}{L} \int_0^L g(x) \cos \frac{n\pi x}{L} dx, \quad n = 1, 2, 3, \dots$$

In Exercises 50-59 use Exercise 49 to solve the initial-boundary value problem. In some of these exercises Theorem 11.3.5(a) will simplify the computation of the coefficients in the Fourier cosine series.

50.  $u_{tt} = 5u_{xx}$ ,  $0 < x < 2$ ,  $t > 0$ ,  
 $u_x(0, t) = 0$ ,  $u_x(2, t) = 0$ ,  $t > 0$ ,  
 $u(x, 0) = 2x^2(3 - x)$ ,  $u_t(x, 0) = 0$ ,  $0 \leq x \leq 2$
51.  $u_{tt} = 5u_{xx}$ ,  $0 < x < 2$ ,  $t > 0$ ,  
 $u_x(0, t) = 0$ ,  $u_x(2, t) = 0$ ,  $t > 0$ ,  
 $u(x, 0) = 0$ ,  $u_t(x, 0) = 2x^2(3 - x)$ ,  $0 \leq x \leq 2$
52.  $u_{tt} = 4u_{xx}$ ,  $0 < x < \pi$ ,  $t > 0$ ,  
 $u_x(0, t) = 0$ ,  $u_x(\pi, t) = 0$ ,  $t > 0$ ,  
 $u(x, 0) = x^3(3x - 4\pi)$ ,  $u_t(x, 0) = 0$ ,  $0 \leq x \leq \pi$
53.  $u_{tt} = 7u_{xx}$ ,  $0 < x < 1$ ,  $t > 0$ ,  
 $u_x(0, t) = 0$ ,  $u_x(1, t) = 0$ ,  $t > 0$ ,  
 $u(x, 0) = 3x^2(x^2 - 2)$ ,  $u_t(x, 0) = 0$ ,  $0 \leq x \leq 1$
54.  $\square$   $u_{tt} = 4u_{xx}$ ,  $0 < x < \pi$ ,  $t > 0$ ,  
 $u_x(0, t) = 0$ ,  $u_x(\pi, t) = 0$ ,  $t > 0$ ,  
 $u(x, 0) = 0$ ,  $u_t(x, 0) = x^3(3x - 4\pi)$ ,  $0 \leq x \leq \pi$
55.  $u_{tt} = 7u_{xx}$ ,  $0 < x < 1$ ,  $t > 0$ ,  
 $u_x(0, t) = 0$ ,  $u_x(1, t) = 0$ ,  $t > 0$ ,  
 $u(x, 0) = 0$ ,  $u_t(x, 0) = 3x^2(x^2 - 2)$ ,  $0 \leq x \leq 1$
56.  $u_{tt} = 16u_{xx}$ ,  $0 < x < \pi$ ,  $t > 0$ ,  
 $u_x(0, t) = 0$ ,  $u_x(\pi, t) = 0$ ,  $t > 0$ ,  
 $u(x, 0) = x^2(x - \pi)^2$ ,  $u_t(x, 0) = 0$ ,  $0 \leq x \leq \pi$
57.  $\square$   $u_{tt} = u_{xx}$ ,  $0 < x < 1$ ,  $t > 0$ ,  
 $u_x(0, t) = 0$ ,  $u_x(1, t) = 0$ ,  $t > 0$ ,  
 $u(x, 0) = x^2(3x^2 - 8x + 6)$ ,  $u_t(x, 0) = 0$ ,  $0 \leq x \leq 1$
58.  $u_{tt} = 16u_{xx}$ ,  $0 < x < \pi$ ,  $t > 0$ ,  
 $u_x(0, t) = 0$ ,  $u_x(\pi, t) = 0$ ,  $t > 0$ ,  
 $u(x, 0) = 0$ ,  $u_t(x, 0) = x^2(x - \pi)^2$ ,  $0 \leq x \leq \pi$
59.  $\square$   $u_{tt} = u_{xx}$ ,  $0 < x < 1$ ,  $t > 0$ ,  
 $u_x(0, t) = 0$ ,  $u_x(1, t) = 0$ ,  $t > 0$ ,  
 $u(x, 0) = 0$ ,  $u_t(x, 0) = x^2(3x^2 - 8x + 6)$ ,  $0 \leq x \leq 1$
60. Adapt the proof of Theorem 12.2.2 to find d'Alembert's solution of the initial-boundary value problem in Exercise 49.
61. Use the result of Exercise 60 to show that the formal solution of the initial-boundary value problem in Exercise 49 is an actual solution if  $g$  is differentiable and  $f$  is twice differentiable on  $[0, L]$  and

$$f'_+(0) = f'_-(L) = g'_+(0) = g'_-(L) = 0.$$

62. Suppose  $\lambda$  and  $\mu$  are constants and either  $p_n(x) = \cos n\lambda x$  or  $p_n(x) = \sin n\lambda x$ , while either  $q_n(t) = \cos n\mu t$  or  $q_n(t) = \sin n\mu t$  for  $n = 1, 2, 3, \dots$ . Let

$$u(x, t) = \sum_{n=1}^{\infty} k_n p_n(x) q_n(t), \quad (\text{A})$$

where  $\{k_n\}_{n=1}^{\infty}$  are constants.

- (a) Show that if  $\sum_{n=1}^{\infty} |k_n|$  converges then  $u(x, t)$  converges for all  $(x, t)$ .  
 (b) Use Theorem 12.1.2 to show that if  $\sum_{n=1}^{\infty} n|k_n|$  converges then (A) can be differentiated term by term with respect to  $x$  and  $t$  for all  $(x, t)$ ; that is,

$$u_x(x, t) = \sum_{n=1}^{\infty} k_n p'_n(x) q_n(t)$$

and

$$u_t(x, t) = \sum_{n=1}^{\infty} k_n p_n(x) q'_n(t).$$

- (c) Suppose  $\sum_{n=1}^{\infty} n^2 |k_n|$  converges. Show that

$$u_{xx}(x, t) = \sum_{n=1}^{\infty} k_n p''_n(x) q_n(t)$$

and

$$u_{tt}(x, t) = \sum_{n=1}^{\infty} k_n p_n(x) q''_n(t)$$

- (d) Suppose  $\sum_{n=1}^{\infty} n^2 |\alpha_n|$  and  $\sum_{n=1}^{\infty} n |\beta_n|$  both converge. Show that the formal solution

$$u(x, t) = \sum_{n=1}^{\infty} \left( \alpha_n \cos \frac{n\pi at}{L} + \frac{\beta_n L}{n\pi a} \sin \frac{n\pi at}{L} \right) \sin \frac{n\pi x}{L}$$

of Equation 12.2.1 satisfies  $u_{tt} = a^2 u_{xx}$  for all  $(x, t)$ .

This conclusion also applies to the formal solutions defined in Exercises 17, 34, and 49.

63. Suppose  $g$  is differentiable and  $f$  is twice differentiable on  $(-\infty, \infty)$ , and let

$$u_0(x, t) = \frac{f(x+at) + f(x-at)}{2} \quad \text{and} \quad u_1(x, t) = \frac{1}{2a} \int_{x-at}^{x+at} g(u) du.$$

- (a) Show that

$$\frac{\partial^2 u_0}{\partial t^2} = a^2 \frac{\partial^2 u_0}{\partial x^2}, \quad -\infty < x < \infty, \quad t > 0,$$

and

$$u_0(x, 0) = f(x), \quad \frac{\partial u_0}{\partial t}(x, 0) = 0, \quad -\infty < x < \infty.$$

- (b) Show that

$$\frac{\partial^2 u_1}{\partial t^2} = a^2 \frac{\partial^2 u_1}{\partial x^2}, \quad -\infty < x < \infty, \quad t > 0,$$

and

$$u_1(x, 0) = 0, \quad \frac{\partial u_1}{\partial t}(x, 0) = g(x), \quad -\infty < x < \infty.$$

(c) Solve

$$u_{tt} = a^2 u_{xx}, \quad -\infty < t < \infty, \quad t > 0,$$

$$u(x, 0) = f(x), \quad u_t(x, 0) = g(x), \quad -\infty < x < \infty.$$

In Exercises 64–68 use the result of Exercise 63 to find a solution of

$$u_{tt} = a^2 u_{xx}, \quad -\infty < x < \infty$$

that satisfies the given initial conditions.

64.  $u(x, 0) = x, \quad u_t(x, 0) = 4ax, \quad -\infty < x < \infty$   
 65.  $u(x, 0) = x^2, \quad u_t(x, 0) = 1, \quad -\infty < x < \infty$   
 66.  $u(x, 0) = \sin x, \quad u_t(x, 0) = a \cos x, \quad -\infty < x < \infty$   
 67.  $u(x, 0) = x^3, \quad u_t(x, 0) = 6x^2, \quad -\infty < x < \infty$   
 68.  $u(x, 0) = x \sin x, \quad u_t(x, 0) = \sin x, \quad -\infty < x < \infty$

### 12.3 LAPLACE'S EQUATION IN RECTANGULAR COORDINATES

The temperature  $u = u(x, y, t)$  in a two-dimensional plate satisfies the two-dimensional heat equation

$$u_t = a^2(u_{xx} + u_{yy}), \quad (12.3.1)$$

where  $(x, y)$  varies over the interior of the plate and  $t > 0$ . To find a solution of (12.3.1), it's necessary to specify the initial temperature  $u(x, y, 0)$  and conditions that must be satisfied on the boundary. However, as  $t \rightarrow \infty$ , the influence of the initial condition decays, so

$$\lim_{t \rightarrow \infty} u_t(x, y, t) = 0$$

and the temperature approaches a steady state distribution  $u = u(x, y)$  that satisfies

$$u_{xx} + u_{yy} = 0. \quad (12.3.2)$$

This is *Laplace's equation*. This equation also arises in applications to fluid mechanics and potential theory; in fact, it is also called *the potential equation*. We seek solutions of (12.3.2) in a region  $R$  that satisfy specified conditions – called *boundary conditions* – on the boundary of  $R$ . For example, we may require  $u$  to assume prescribed values on the boundary. This is called a *Dirichlet condition*, and the problem is called a *Dirichlet problem*. Or, we may require the normal derivative of  $u$  at each point  $(x, y)$  on the boundary to assume prescribed values. This is called a *Neumann condition*, and the problem is called a *Neumann problem*. In some problems we impose Dirichlet conditions on part of the boundary and Neumann conditions on the rest. Then we say that the boundary conditions and the problem are *mixed*.

Solving boundary value problems for (12.3.2) over general regions is beyond the scope of this book, so we consider only very simple regions. We begin by considering the rectangular region shown in Figure 12.3.1.

The possible boundary conditions for this region can be written as

$$\begin{aligned} (1 - \alpha)u(x, 0) + \alpha u_y(x, 0) &= f_0(x), & 0 \leq x \leq a, \\ (1 - \beta)u(x, b) + \beta u_y(x, b) &= f_1(x), & 0 \leq x \leq a, \\ (1 - \gamma)u(0, y) + \gamma u_x(0, y) &= g_0(y), & 0 \leq y \leq b, \\ (1 - \delta)u(a, y) + \delta u_x(a, y) &= g_1(y), & 0 \leq y \leq b, \end{aligned}$$



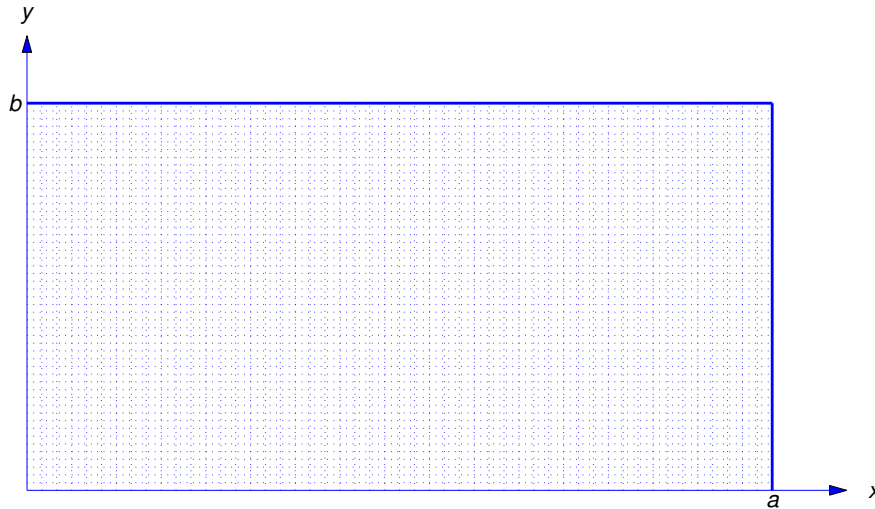

Figure 12.3.1 A rectangular region and its boundary

where  $\alpha, \beta, \gamma,$  and  $\delta$  can each be either 0 or 1; thus, there are 16 possibilities. Let  $\text{BVP}(\alpha, \beta, \gamma, \delta)(f_0, f_1, g_0, g_1)$  denote the problem of finding a solution of (12.3.2) that satisfies these conditions. This is a Dirichlet problem if

$$\alpha = \beta = \gamma = \delta = 0$$

(Figure 12.3.2), or a Neumann problem if

$$\alpha = \beta = \gamma = \delta = 1$$

(Figure 12.3.3). The other 14 problems are mixed.

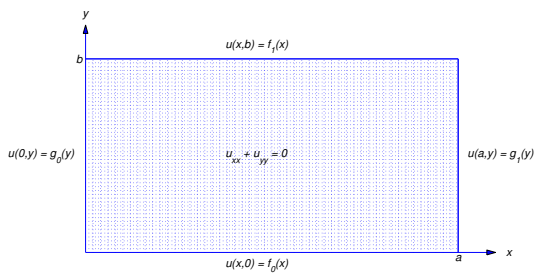

Figure 12.3.2 A Dirichlet problem

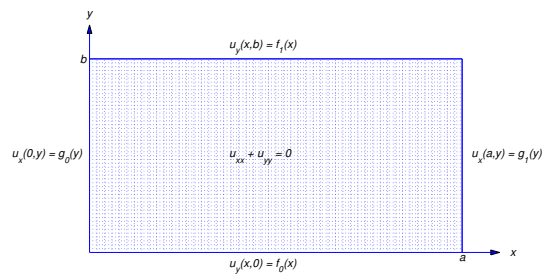

Figure 12.3.3 A Neumann problem

For given  $(\alpha, \beta, \gamma, \delta)$ , the sum of solutions of

$$\text{BVP}(\alpha, \beta, \gamma, \delta)(f_0, 0, 0, 0), \quad \text{BVP}(\alpha, \beta, \gamma, \delta)(0, f_1, 0, 0),$$

$$\text{BVP}(\alpha, \beta, \gamma, \delta)(0, 0, g_0, 0), \quad \text{and} \quad \text{BVP}(\alpha, \beta, \gamma, \delta)(0, 0, 0, g_1)$$

is a solution of

$$\text{BVP}(\alpha, \beta, \gamma, \delta)(f_0, f_1, g_0, g_1).$$

Therefore we concentrate on problems where only one of the functions  $f_0, f_1, g_0, g_1$  isn't identically zero. There are 64 (count them!) problems of this form. Each has homogeneous boundary conditions on three sides of the rectangle, and a nonhomogeneous boundary condition on the fourth. We use separation of variables to find infinitely many functions that satisfy Laplace's equation and the three homogeneous boundary conditions in the open rectangle. We then use these solutions as building blocks to construct a formal solution of Laplace's equation that also satisfies the nonhomogeneous boundary condition. Since it's not feasible to consider all 64 cases, we'll restrict our attention in the text to just four. Others are discussed in the exercises.

If  $v(x, y) = X(x)Y(y)$  then

$$v_{xx} + v_{yy} = X''Y + XY'' = 0$$

for all  $(x, y)$  if and only if

$$\frac{X''}{X} = -\frac{Y''}{Y} = k$$

for all  $(x, y)$ , where  $k$  is a separation constant. This equation is equivalent to

$$X'' - kX = 0, \quad Y'' + kY = 0. \quad (12.3.3)$$

From here, the strategy depends upon the boundary conditions. We illustrate this by examples.

**Example 12.3.1** Define the formal solution of

$$\begin{aligned} u_{xx} + u_{yy} &= 0, & 0 < x < a, & \quad 0 < y < b, \\ u(x, 0) &= f(x), & u(x, b) &= 0, & \quad 0 \leq x \leq a, \\ u(0, y) &= 0, & u(a, y) &= 0, & \quad 0 \leq y \leq b \end{aligned} \quad (12.3.4)$$

(Figure 12.3.4).

**Solution** The boundary conditions in (12.3.4) require products  $v(x, y) = X(x)Y(y)$  such that  $X(0) = X(a) = Y(b) = 0$ ; hence, we let  $k = -\lambda$  in (12.3.3). Thus,  $X$  and  $Y$  must satisfy

$$X'' + \lambda X = 0, \quad X(0) = 0, \quad X(a) = 0 \quad (12.3.5)$$

and

$$Y'' - \lambda Y = 0, \quad Y(b) = 0. \quad (12.3.6)$$

From Theorem 11.1.2, the eigenvalues of (12.3.5) are  $\lambda_n = n^2\pi^2/a^2$ , with associated eigenfunctions

$$X_n = \sin \frac{n\pi x}{a}, \quad n = 1, 2, 3, \dots$$

Substituting  $\lambda = n^2\pi^2/a^2$  into (12.3.6) yields

$$Y'' - (n^2\pi^2/a^2)Y = 0, \quad Y(b) = 0,$$

so we could take

$$Y_n = \sinh \frac{n\pi(b-y)}{a}; \quad (12.3.7)$$

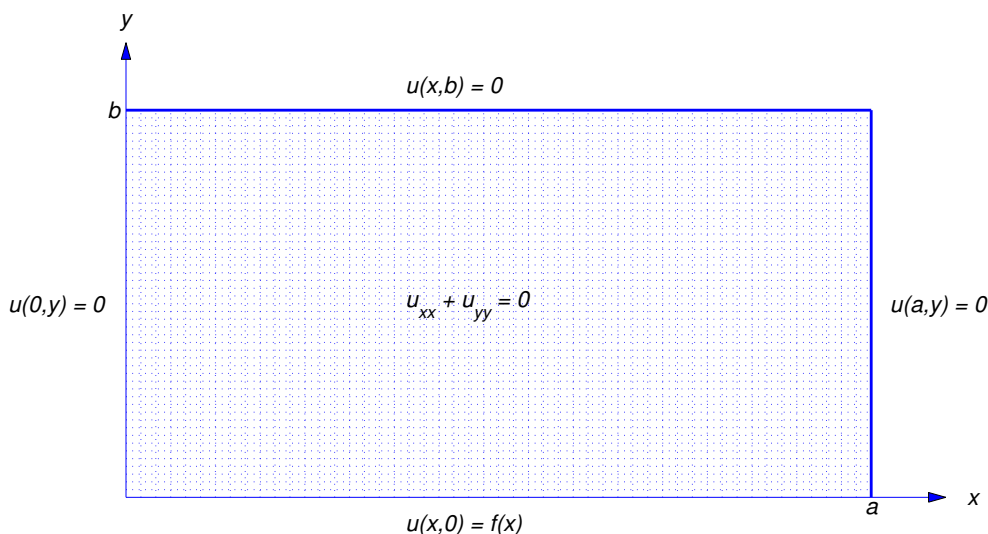

Figure 12.3.4 The boundary value problem (12.3.4)

however, because of the nonhomogeneous Dirichlet condition at  $y = 0$ , it's better to require that  $Y_n(0) = 1$ , which can be achieved by dividing the right side of (12.3.7) by its value at  $y = 0$ ; thus, we take

$$Y_n = \frac{\sinh n\pi(b-y)/a}{\sinh n\pi b/a}.$$

Then

$$v_n(x, y) = X_n(x)Y_n(y) = \frac{\sinh n\pi(b-y)/a}{\sinh n\pi b/a} \sin \frac{n\pi x}{a},$$

so  $v_n(x, 0) = \sin n\pi x/a$  and  $v_n$  satisfies (12.3.4) with  $f(x) = \sin n\pi x/a$ . More generally, if  $\alpha_1, \dots, \alpha_m$  are arbitrary constants then

$$u_m(x, y) = \sum_{n=1}^m \alpha_n \frac{\sinh n\pi(b-y)/a}{\sinh n\pi b/a} \sin \frac{n\pi x}{a}$$

satisfies (12.3.4) with

$$f(x) = \sum_{n=1}^m \alpha_n \sin \frac{n\pi x}{L}.$$

Therefore, if  $f$  is an arbitrary piecewise smooth function on  $[0, a]$ , we define the formal solution of (12.3.4) to be

$$u(x, y) = \sum_{n=1}^{\infty} \alpha_n \frac{\sinh n\pi(b-y)/a}{\sinh n\pi b/a} \sin \frac{n\pi x}{a}, \quad (12.3.8)$$

where

$$S(x) = \sum_{n=1}^{\infty} \alpha_n \sin \frac{n\pi x}{a}$$

is the Fourier sine series of  $f$  on  $[0, a]$ ; that is,

$$\alpha_n = \frac{2}{a} \int_0^a f(x) \sin \frac{n\pi x}{a} dx, \quad n = 1, 2, 3, \dots \quad \blacksquare$$

If  $y < b$  then

$$\frac{\sinh n\pi(b-y)/a}{\sinh n\pi b/a} \approx e^{-n\pi y/a} \quad (12.3.9)$$

for large  $n$ , so the series in (12.3.8) converges if  $0 < y < b$ ; moreover, since also

$$\frac{\cosh n\pi(b-y)/a}{\sinh n\pi b/a} \approx e^{-n\pi y/a}$$

for large  $n$ , Theorem 12.1.2 applied twice with  $z = x$  and twice with  $z = t$ , shows that  $u_{xx}$  and  $u_{yy}$  can be obtained by differentiating  $u$  term by term if  $0 < y < b$ . (Exercise 37). Therefore  $u$  satisfies Laplace's equation in the interior of the rectangle in Figure 12.3.4. Moreover, the series in (12.3.8) also converges on the boundary of the rectangle, and satisfies the three homogeneous boundary conditions conditions in (12.3.4). Therefore, since  $u(x, 0) = S(x)$  for  $0 \leq x \leq L$ ,  $u$  is an actual solution of (12.3.5) if and only if  $S(x) = f(x)$  for  $0 \leq x \leq a$ . From Theorem 11.3.2, this is true if  $f$  is continuous and piecewise smooth on  $[0, L]$ , and  $f(0) = f(L) = 0$ .

**Example 12.3.2** Solve (12.3.4) with  $f(x) = x(x^2 - 3ax + 2a^2)$ .

**Solution** From Example 11.3.6,

$$S(x) = \frac{12a^3}{\pi^3} \sum_{n=1}^{\infty} \frac{1}{n^3} \sin \frac{n\pi x}{a}.$$

Therefore

$$u(x, y) = \frac{12a^3}{\pi^3} \sum_{n=1}^{\infty} \frac{\sinh n\pi(b-y)/a}{n^3 \sinh n\pi b/a} \sin \frac{n\pi x}{a}. \quad (12.3.10)$$

To compute approximate values of  $u(x, y)$ , we must use partial sums of the form

$$u_m(x, y) = \frac{12a^3}{\pi^3} \sum_{n=1}^m \frac{\sinh n\pi(b-y)/a}{n^3 \sinh n\pi b/a} \sin \frac{n\pi x}{a}.$$

Because of (12.3.9), small values of  $m$  provide sufficient accuracy for most applications if  $0 < y < b$ . Moreover, the  $n^3$  in the denominator in (12.3.10) ensures that this is also true for  $y = 0$ . For graphing purposes, we chose  $a = 2$ ,  $b = 1$ , and  $m = 10$ . Figure 12.3.5 shows the surface

$$u = u(x, y), \quad 0 \leq x \leq 2, \quad 0 \leq y \leq 1,$$

while Figure 12.3.6 shows the curves

$$u = u(x, 0.1k), \quad 0 \leq x \leq 2, \quad k = 0, 1, \dots, 10.$$

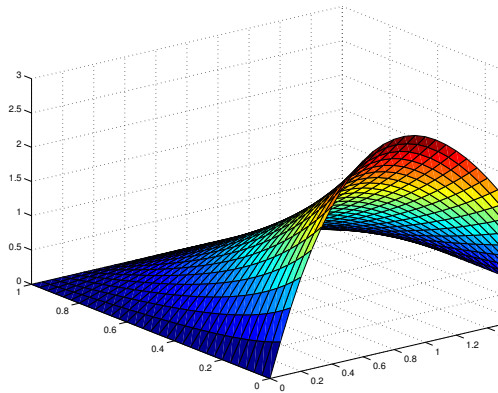

Figure 12.3.5

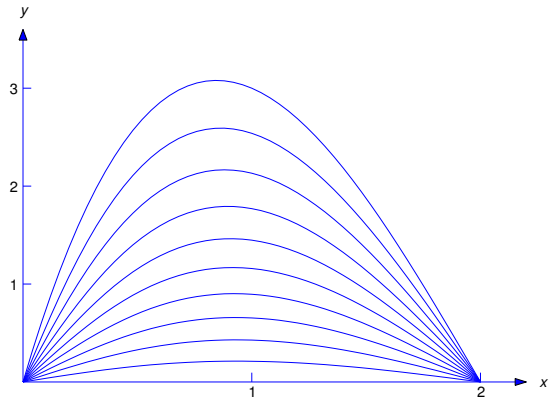

Figure 12.3.6

**Example 12.3.3** Define the formal solution of

$$\begin{aligned}
 u_{xx} + u_{yy} &= 0, & 0 < x < a, & & 0 < y < b, \\
 u(x, 0) &= 0, & u_y(x, b) &= f(x), & 0 \leq x \leq a, \\
 u_x(0, y) &= 0, & u_x(a, y) &= 0, & 0 \leq y \leq b
 \end{aligned}
 \tag{12.3.11}$$

(Figure 12.3.7).

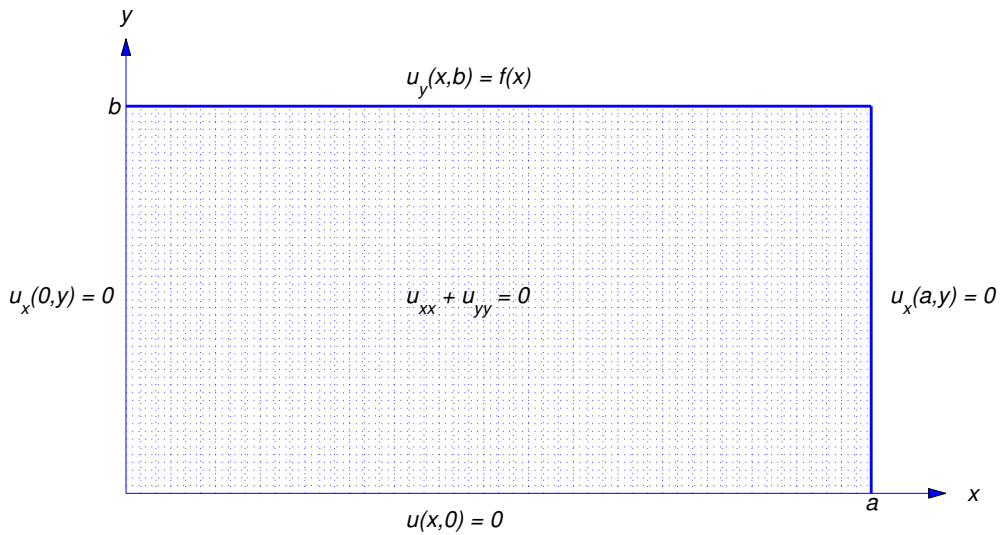

Figure 12.3.7 The boundary value problem (12.3.11)

**Solution** The boundary conditions in (12.3.11) require products  $v(x, y) = X(x)Y(y)$  such that  $X'(0) =$

$X'(a) = Y(0) = 0$ ; hence, we let  $k = -\lambda$  in (12.3.3). Thus,  $X$  and  $Y$  must satisfy

$$X'' + \lambda X = 0, \quad X'(0) = 0, \quad X'(a) = 0 \quad (12.3.12)$$

and

$$Y'' - \lambda Y = 0, \quad Y(0) = 0. \quad (12.3.13)$$

From Theorem 11.1.3, the eigenvalues of (12.3.12) are  $\lambda = 0$ , with associated eigenfunction  $X_0 = 1$ , and  $\lambda_n = n^2\pi^2/a^2$ , with associated eigenfunctions

$$X_n = \cos \frac{n\pi x}{a}, \quad n = 1, 2, 3, \dots$$

Since  $Y_0 = y$  satisfies (12.3.13) with  $\lambda = 0$ , we take  $v_0(x, y) = X_0(x)Y_0(y) = y$ . Substituting  $\lambda = n^2\pi^2/a^2$  into (12.3.13) yields

$$Y'' - (n^2\pi^2/a^2)Y = 0, \quad Y(0) = 0,$$

so we could take

$$Y_n = \sinh \frac{n\pi y}{a}. \quad (12.3.14)$$

However, because of the nonhomogeneous Neumann condition at  $y = b$ , it's better to require that  $Y'_n(b) = 1$ , which can be achieved by dividing the right side of (12.3.14) by the value of its derivative at  $y = b$ ; thus,

$$Y_n = \frac{a \sinh n\pi y/a}{n\pi \cosh n\pi b/a}.$$

Then

$$v_n(x, y) = X_n(x)Y_n(y) = \frac{a \sinh n\pi y/a}{n\pi \cosh n\pi b/a} \cos \frac{n\pi x}{a},$$

so

$$\frac{\partial v_n}{\partial y}(x, b) = \cos \frac{n\pi x}{a}.$$

Therefore  $v_n$  satisfies (12.3.11) with  $f(x) = \cos n\pi x/a$ . More generally, if  $\alpha_0, \dots, \alpha_m$  are arbitrary constants then

$$u_m(x, y) = \alpha_0 y + \frac{a}{\pi} \sum_{n=1}^m \alpha_n \frac{\sinh n\pi y/a}{n \cosh n\pi b/a} \cos \frac{n\pi x}{a}$$

satisfies (12.3.11) with

$$f(x) = \alpha_0 + \sum_{n=1}^m \alpha_n \cos \frac{n\pi x}{L}.$$

Therefore, if  $f$  is an arbitrary piecewise smooth function on  $[0, a]$  we define the formal solution of (12.3.11) to be

$$u(x, y) = \alpha_0 y + \frac{a}{\pi} \sum_{n=1}^{\infty} \alpha_n \frac{\sinh n\pi y/a}{n \cosh n\pi b/a} \cos \frac{n\pi x}{a},$$

where

$$C(x) = \alpha_0 + \sum_{n=1}^{\infty} \alpha_n \cos \frac{n\pi x}{a}$$

is the Fourier cosine series of  $f$  on  $[0, a]$ ; that is,

$$\alpha_0 = \frac{1}{a} \int_0^a f(x) dx \quad \text{and} \quad \alpha_n = \frac{2}{a} \int_0^a f(x) \cos \frac{n\pi x}{a} dx, \quad n = 1, 2, 3, \dots$$

**Example 12.3.4** Solve (12.3.11) with  $f(x) = x$ .

**Solution** From Example 11.3.1,

$$C(x) = \frac{a}{2} - \frac{4a}{\pi^2} \sum_{n=1}^{\infty} \frac{1}{(2n-1)^2} \cos \frac{(2n-1)\pi x}{a}.$$

Therefore

$$u(x, y) = \frac{ay}{2} - \frac{4a^2}{\pi^3} \sum_{n=1}^{\infty} \frac{\sinh(2n-1)\pi y/a}{(2n-1)^3 \cosh(2n-1)\pi b/a} \cos \frac{(2n-1)\pi x}{a}. \quad (12.3.15)$$

For graphing purposes, we chose  $a = 2$ ,  $b = 1$ , and retained the terms through  $n = 10$  in (12.3.15). Figure 12.3.8 shows the surface

$$u = u(x, y), \quad 0 \leq x \leq 2, \quad 0 \leq y \leq 1,$$

while Figure 12.3.9 shows the curves

$$u = u(x, .1k), \quad 0 \leq x \leq 2, \quad k = 0, 1, \dots, 10.$$

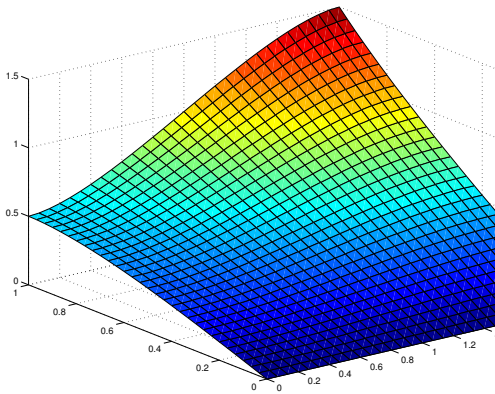

Figure 12.3.8

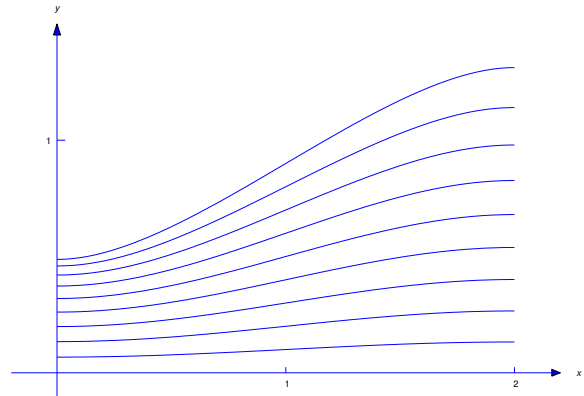

Figure 12.3.9

**Example 12.3.5** Define the formal solution of

$$\begin{aligned} u_{xx} + u_{yy} &= 0, & 0 < x < a, & \quad 0 < y < b, \\ u(x, 0) &= 0, & u_y(x, b) &= 0, & \quad 0 \leq x \leq a, \\ u(0, y) &= g(y), & u_x(a, y) &= 0, & \quad 0 \leq y \leq b \end{aligned} \quad (12.3.16)$$

(Figure 12.3.10).

**Solution** The boundary conditions in (12.3.16) require products  $v(x, y) = X(x)Y(y)$  such that  $Y(0) = Y'(b) = X'(a) = 0$ ; hence, we let  $k = \lambda$  in (12.3.3). Thus,  $X$  and  $Y$  must satisfy

$$X'' - \lambda X = 0, \quad X'(a) = 0 \quad (12.3.17)$$

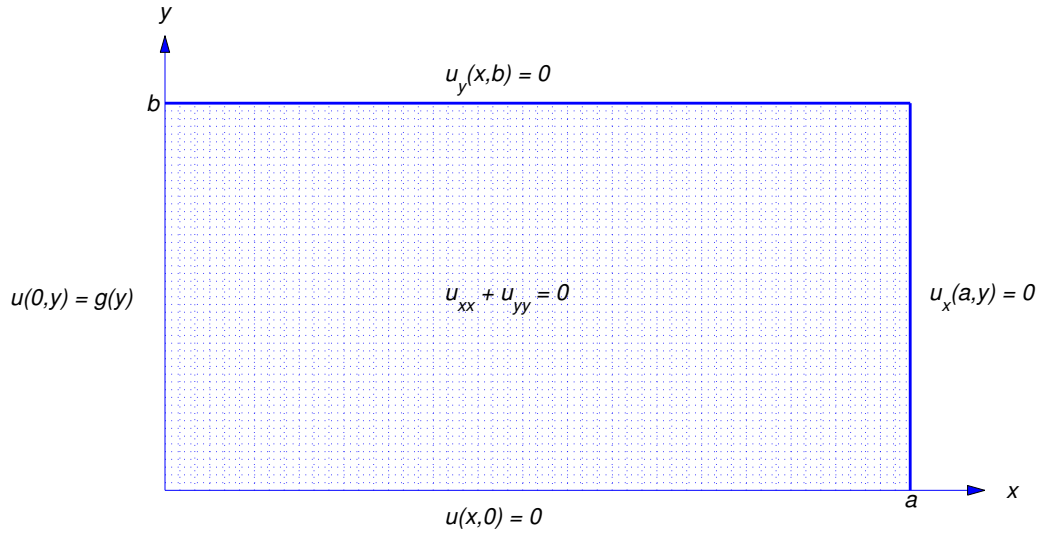

Figure 12.3.10 The boundary value problem (12.3.16)

and

$$Y'' + \lambda Y = 0, \quad Y(0) = 0, \quad Y'(b) = 0. \tag{12.3.18}$$

From Theorem 11.1.4, the eigenvalues of (12.3.18) are  $\lambda_n = (2n - 1)^2\pi^2/4b^2$ , with associated eigenfunctions

$$Y_n = \sin \frac{(2n - 1)\pi y}{2b}, \quad n = 1, 2, 3, \dots$$

Substituting  $\lambda = (2n - 1)^2\pi^2/4b^2$  into (12.3.17) yields

$$X'' - ((2n - 1)^2\pi^2/4b^2)X = 0, \quad X'(a) = 0,$$

so we could take

$$X_n = \cosh \frac{(2n - 1)\pi(x - a)}{2b}. \tag{12.3.19}$$

However, because of the nonhomogeneous Dirichlet condition at  $x = 0$ , it's better to require that  $X_n(0) = 1$ , which can be achieved by dividing the right side of (12.3.19) by its value at  $x = 0$ ; thus,

$$X_n = \frac{\cosh(2n - 1)\pi(x - a)/2b}{\cosh(2n - 1)\pi a/2b}.$$

Then

$$v_n(x, y) = X_n(x)Y_n(y) = \frac{\cosh(2n - 1)\pi(x - a)/2b}{\cosh(2n - 1)\pi a/2b} \sin \frac{(2n - 1)\pi y}{2b},$$

so

$$v_n(0, y) = \sin \frac{(2n - 1)\pi y}{2b}.$$



Therefore  $v_n$  satisfies (12.3.16) with  $g(y) = \sin(2n-1)\pi y/2b$ . More generally, if  $\alpha_1, \dots, \alpha_m$  are arbitrary constants then

$$u_m(x, y) = \sum_{n=1}^m \alpha_n \frac{\cosh(2n-1)\pi(x-a)/2b}{\cosh(2n-1)\pi a/2b} \sin \frac{(2n-1)\pi y}{2b}$$

satisfies (12.3.16) with

$$g(y) = \sum_{n=1}^m \alpha_n \sin \frac{(2n-1)\pi y}{2b}.$$

Thus, if  $g$  is an arbitrary piecewise smooth function on  $[0, b]$ , we define the formal solution of (12.3.16) to be

$$u(x, y) = \sum_{n=1}^{\infty} \alpha_n \frac{\cosh(2n-1)\pi(x-a)/2b}{\cosh(2n-1)\pi a/2b} \sin \frac{(2n-1)\pi y}{2b},$$

where

$$S_M(x) = \sum_{n=1}^{\infty} \alpha_n \sin \frac{(2n-1)\pi y}{2b}$$

is the mixed Fourier sine series of  $g$  on  $[0, b]$ ; that is,

$$\alpha_n = \frac{2}{b} \int_0^b g(y) \sin \frac{(2n-1)\pi y}{2b} dy.$$

**Example 12.3.6** Solve (12.3.16) with  $g(y) = y(2y^2 - 9by + 12b^2)$ .

**Solution** From Example 11.3.8,

$$S_M(y) = \frac{96b^3}{\pi^3} \sum_{n=1}^{\infty} \frac{1}{(2n-1)^3} \left[ 3 + (-1)^n \frac{4}{(2n-1)\pi} \right] \sin \frac{(2n-1)\pi y}{2b}.$$

Therefore

$$u(x, y) = \frac{96b^3}{\pi^3} \sum_{n=1}^{\infty} \frac{\cosh(2n-1)\pi(x-a)/2b}{(2n-1)^3 \cosh(2n-1)\pi a/2b} \left[ 3 + (-1)^n \frac{4}{(2n-1)\pi} \right] \sin \frac{(2n-1)\pi y}{2b}.$$

**Example 12.3.7** Define the formal solution of

$$\begin{aligned} u_{xx} + u_{yy} &= 0, & 0 < x < a, & & 0 < y < b, \\ u_y(x, 0) &= 0, & u(x, b) &= 0, & 0 \leq x \leq a, \\ u_x(0, y) &= 0, & u_x(a, y) &= g(y), & 0 \leq y \leq b \end{aligned} \tag{12.3.20}$$

(Figure 12.3.11).

**Solution** The boundary conditions in (12.3.20) require products  $v(x, y) = X(x)Y(y)$  such that  $Y'(0) = Y(b) = X'(0) = 0$ ; hence, we let  $k = \lambda$  in (12.3.3). Thus,  $X$  and  $Y$  must satisfy

$$X'' - \lambda X = 0, \quad X'(0) = 0 \tag{12.3.21}$$

and

$$Y'' + \lambda Y = 0, \quad Y'(0) = 0, \quad Y(b) = 0. \tag{12.3.22}$$

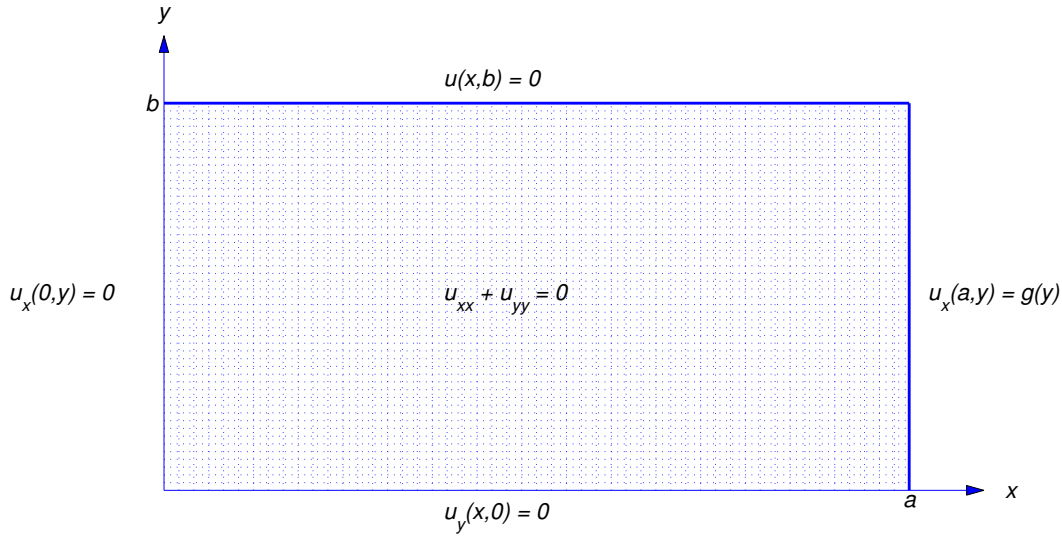

Figure 12.3.11 The boundary value problem (12.3.20)

From Theorem 11.1.4, the eigenvalues of (12.3.22) are  $\lambda_n = (2n - 1)^2\pi^2/4b^2$ , with associated eigenfunctions

$$Y_n = \cos \frac{(2n - 1)\pi y}{2b}, \quad n = 1, 2, 3, \dots$$

Substituting  $\lambda = (2n - 1)^2\pi^2/4b^2$  into (12.3.21) yields

$$X'' - ((2n - 1)^2\pi^2/4b^2)X = 0, \quad X'(0) = 0,$$

so we could take

$$X_n = \cosh \frac{(2n - 1)\pi x}{2b}. \tag{12.3.23}$$

However, because of the nonhomogeneous Neumann condition at  $x = a$ , it's better to require that  $X'_n(a) = 1$ , which can be achieved by dividing the right side of (12.3.23) by the value of its derivative at  $x = a$ ; thus,

$$X_n = \frac{2b \cosh(2n - 1)\pi x/2b}{(2n - 1)\pi \sinh(2n - 1)\pi a/2b}.$$

Then

$$v_n(x, y) = X_n(x)Y_n(y) = \frac{2b \cosh(2n - 1)\pi x/2b}{(2n - 1)\pi \sinh(2n - 1)\pi a/2b} \cos \frac{(2n - 1)\pi y}{2b},$$

so

$$\frac{\partial v_n}{\partial x}(a, y) = \cos \frac{(2n - 1)\pi y}{2b}.$$

Therefore  $v_n$  satisfies (12.3.20) with  $g(y) = \cos(2n - 1)\pi y/2b$ . More generally, if  $\alpha_1, \dots, \alpha_m$  are arbitrary constants then

$$u_m(x, y) = \frac{2b}{\pi} \sum_{n=1}^m \alpha_n \frac{\cosh(2n - 1)\pi x/2b}{(2n - 1)\pi \sinh(2n - 1)\pi a/2b} \cos \frac{(2n - 1)\pi y}{2b}$$

satisfies (12.3.20) with

$$g(y) = \sum_{n=1}^{\infty} \alpha_n \cos \frac{(2n-1)\pi y}{2b}.$$

Therefore, if  $g$  is an arbitrary piecewise smooth function on  $[0, b]$ , we define the formal solution of (12.3.20) to be

$$u(x, y) = \frac{2b}{\pi} \sum_{n=1}^{\infty} \alpha_n \frac{\cosh(2n-1)\pi x/2b}{(2n-1) \sinh(2n-1)\pi a/2b} \cos \frac{(2n-1)\pi y}{2b},$$

where

$$C_M(y) = \sum_{n=1}^{\infty} \alpha_n \cos \frac{(2n-1)\pi y}{2b}$$

is the mixed Fourier cosine series of  $g$  on  $[0, b]$ ; that is,

$$\alpha_n = \frac{2}{b} \int_0^b g(y) \cos \frac{(2n-1)\pi y}{2b} dy.$$

**Example 12.3.8** Solve (12.3.20) with  $g(y) = y - b$ .

**Solution** From Example 11.3.3,

$$C_M(y) = -\frac{8b}{\pi^2} \sum_{n=1}^{\infty} \frac{1}{(2n-1)^2} \cos \frac{(2n-1)\pi y}{2b}.$$

Therefore

$$u(x, y) = -\frac{16b^2}{\pi^3} \sum_{n=1}^{\infty} \frac{\cosh(2n-1)\pi x/2b}{(2n-1)^3 \sinh(2n-1)\pi a/2b} \cos \frac{(2n-1)\pi y}{2b}. \quad \blacksquare$$

### Laplace's Equation for a Semi-Infinite Strip

We now seek solutions of Laplace's equation on the semi-infinite strip

$$S : \{0 < x < a, \quad y > 0\}$$

(Figure 12.3.12) that satisfy homogeneous boundary conditions at  $x = 0$  and  $x = a$ , and a nonhomogeneous Dirichlet or Neumann condition at  $y = 0$ . An example of such a problem is

$$\begin{aligned} u_{xx} + u_{yy} &= 0, & 0 < x < a, & \quad y > 0, \\ u(x, 0) &= f(x), & 0 \leq x \leq a, & \\ u(0, y) &= 0, \quad u(a, y) = 0, & y > 0, & \end{aligned} \quad (12.3.24)$$

The boundary conditions in this problem are not sufficient to determine  $u$ , for if  $u_0 = u_0(x, y)$  is a solution and  $K$  is a constant then

$$u_1(x, y) = u_0(x, y) + K \sin \frac{\pi x}{a} \sinh \frac{\pi y}{a}.$$

is also a solution. (Verify.) However, if we also require — on physical grounds — that the solution remain bounded for all  $(x, y)$  in  $S$  then  $K = 0$  and this difficulty is eliminated.

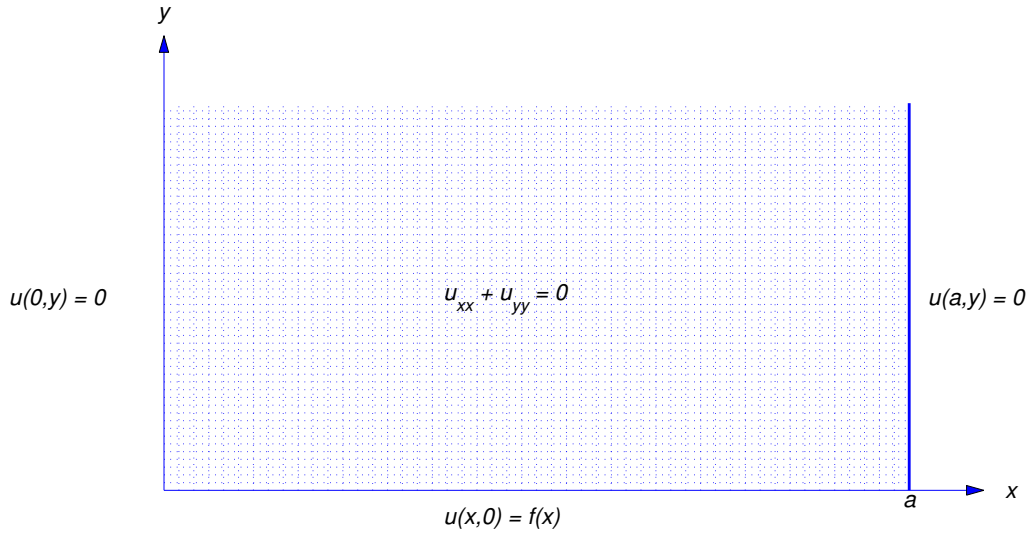

Figure 12.3.12 A boundary value problem on a semi-infinite strip

**Example 12.3.9** Define the bounded formal solution of (12.3.24).

**Solution** Proceeding as in the solution of Example 12.3.1, we find that the building block functions are of the form

$$v_n(x, y) = Y_n(y) \sin \frac{n\pi x}{a},$$

where

$$Y_n'' - (n^2 \pi^2 / a^2) Y_n = 0.$$

Therefore

$$Y_n = c_1 e^{n\pi y/a} + c_2 e^{-n\pi y/a}$$

where  $c_1$  and  $c_2$  are constants. Although the boundary conditions in (12.3.24) don't restrict  $c_1$ , and  $c_2$ , we must set  $c_1 = 0$  to ensure that  $Y_n$  is bounded. Letting  $c_2 = 1$  yields

$$v_n(x, y) = e^{-n\pi y/a} \sin \frac{n\pi x}{a},$$

and we define the bounded formal solution of (12.3.24) to be

$$u(x, y) = \sum_{n=1}^{\infty} b_n e^{-n\pi y/a} \sin \frac{n\pi x}{a},$$

where

$$S(x) = \sum_{n=1}^{\infty} b_n \sin \frac{n\pi x}{a}$$

is the Fourier sine series of  $f$  on  $[0, a]$ . ■

See Exercises 29-34 for other boundary value problems on a semi-infinite strip.

### 12.3 Exercises

In Exercises 1-16 apply the definition developed in Example 1 to solve the boundary value problem. (Use Theorem 11.3.5 where it applies.) Where indicated by C, graph the surface  $u = u(x, y)$ ,  $0 \leq x \leq a$ ,  $0 \leq y \leq b$ .

1.  $u_{xx} + u_{yy} = 0$ ,  $0 < x < 1$ ,  $0 < y < 1$ ,  
 $u(x, 0) = x(1 - x)$ ,  $u(x, 1) = 0$ ,  $0 \leq x \leq 1$ ,  
 $u(0, y) = 0$ ,  $u(1, y) = 0$ ,  $0 \leq y \leq 1$
2.  $u_{xx} + u_{yy} = 0$ ,  $0 < x < 2$ ,  $0 < y < 3$ ,  
 $u(x, 0) = x^2(2 - x)$ ,  $u(x, 3) = 0$ ,  $0 \leq x \leq 2$ ,  
 $u(0, y) = 0$ ,  $u(2, y) = 0$ ,  $0 \leq y \leq 3$
3. C  $u_{xx} + u_{yy} = 0$ ,  $0 < x < 2$ ,  $0 < y < 2$ ,  
 $u(x, 0) = \begin{cases} x, & 0 \leq x \leq 1, \\ 2 - x, & 1 \leq x \leq 2, \end{cases}$   $u(x, 2) = 0$ ,  $0 \leq x \leq 2$ ,  
 $u(0, y) = 0$ ,  $u(2, y) = 0$ ,  $0 \leq y \leq 2$
4.  $u_{xx} + u_{yy} = 0$ ,  $0 < x < \pi$ ,  $0 < y < 1$ ,  
 $u(x, 0) = x \sin x$ ,  $u(x, \pi) = 0$ ,  $0 \leq x \leq \pi$ ,  
 $u(0, y) = 0$ ,  $u(\pi, y) = 0$ ,  $0 \leq y \leq 1$
5.  $u_{xx} + u_{yy} = 0$ ,  $0 < x < 3$ ,  $0 < y < 2$ ,  
 $u(x, 0) = 0$ ,  $u_y(x, 2) = x^2$ ,  $0 \leq x \leq 3$ ,  
 $u_x(0, y) = 0$ ,  $u_x(3, y) = 0$ ,  $0 \leq y \leq 2$
6.  $u_{xx} + u_{yy} = 0$ ,  $0 < x < 1$ ,  $0 < y < 2$ ,  
 $u(x, 0) = 0$ ,  $u_y(x, 2) = 1 - x$ ,  $0 \leq x \leq 1$ ,  
 $u_x(0, y) = 0$ ,  $u_x(1, y) = 0$ ,  $0 \leq y \leq 2$
7.  $u_{xx} + u_{yy} = 0$ ,  $0 < x < 2$ ,  $0 < y < 2$ ,  
 $u(x, 0) = 0$ ,  $u_y(x, 2) = x^2 - 4$ ,  $0 \leq x \leq 2$ ,  
 $u_x(0, y) = 0$ ,  $u_x(2, y) = 0$ ,  $0 \leq y \leq 2$
8.  $u_{xx} + u_{yy} = 0$ ,  $0 < x < 1$ ,  $0 < y < 1$ ,  
 $u(x, 0) = 0$ ,  $u_y(x, 1) = (x - 1)^2$ ,  $0 \leq x \leq 1$ ,  
 $u_x(0, y) = 0$ ,  $u_x(1, y) = 0$ ,  $0 \leq y \leq 1$
9. C  $u_{xx} + u_{yy} = 0$ ,  $0 < x < 3$ ,  $0 < y < 2$ ,  
 $u(x, 0) = 0$ ,  $u_y(x, 2) = 0$ ,  $0 \leq x \leq 3$ ,  
 $u(0, y) = y(4 - y)$ ,  $u_x(3, y) = 0$ ,  $0 \leq y \leq 2$
10.  $u_{xx} + u_{yy} = 0$ ,  $0 < x < 2$ ,  $0 < y < 1$ ,  
 $u(x, 0) = 0$ ,  $u_y(x, 1) = 0$ ,  $0 \leq x \leq 2$ ,  
 $u(0, y) = y^2(3 - 2y)$ ,  $u_x(2, y) = 0$ ,  $0 \leq y \leq 1$
11.  $u_{xx} + u_{yy} = 0$ ,  $0 < x < 2$ ,  $0 < y < 2$ ,  
 $u(x, 0) = 0$ ,  $u_y(x, 2) = 0$ ,  $0 \leq x \leq 2$ ,  
 $u(0, y) = (y - 2)^3 + 8$ ,  $u_x(2, y) = 0$ ,  $0 \leq y \leq 2$
12.  $u_{xx} + u_{yy} = 0$ ,  $0 < x < 3$ ,  $0 < y < 1$ ,  
 $u(x, 0) = 0$ ,  $u_y(x, 1) = 0$ ,  $0 \leq x \leq 3$ ,  
 $u(0, y) = y(2y^2 - 9y + 12)$ ,  $u_x(3, y) = 0$ ,  $0 \leq y \leq 1$

13.  $\square C$   $u_{xx} + u_{yy} = 0$ ,  $0 < x < 1$ ,  $0 < y < \pi$ ,  
 $u_y(x, 0) = 0$ ,  $u(x, \pi) = 0$ ,  $0 \leq x \leq 1$ ,  
 $u_x(0, y) = 0$ ,  $u_x(1, y) = \sin y$ ,  $0 \leq y \leq \pi$
14.  $u_{xx} + u_{yy} = 0$ ,  $0 < x < 2$ ,  $0 < y < 3$ ,  
 $u_y(x, 0) = 0$ ,  $u(x, 3) = 0$ ,  $0 \leq x \leq 2$ ,  
 $u_x(0, y) = 0$ ,  $u_x(2, y) = y(3 - y)$ ,  $0 \leq y \leq 3$
15.  $u_{xx} + u_{yy} = 0$ ,  $0 < x < 1$ ,  $0 < y < \pi$ ,  
 $u_y(x, 0) = 0$ ,  $u(x, \pi) = 0$ ,  $0 \leq x \leq 1$ ,  
 $u_x(0, y) = 0$ ,  $u_x(1, y) = \pi^2 - y^2$ ,  $0 \leq y \leq \pi$
16.  $u_{xx} + u_{yy} = 0$ ,  $0 < x < 1$ ,  $0 < y < 1$ ,  
 $u_y(x, 0) = 0$ ,  $u(x, 1) = 0$ ,  $0 \leq x \leq 1$ ,  
 $u_x(0, y) = 0$ ,  $u_x(1, y) = 1 - y^3$ ,  $0 \leq y \leq 1$

In Exercises 17-28 define the formal solution of

$$u_{xx} + u_{yy} = 0, \quad 0 < x < a, \quad 0 < y < b$$

that satisfies the given boundary conditions for general  $a$ ,  $b$ , and  $f$  or  $g$ . Then solve the boundary value problem for the specified  $a$ ,  $b$ , and  $f$  or  $g$ . (Use Theorem 11.3.5 where it applies.) Where indicated by  $\square C$ , graph the surface  $u = u(x, y)$ ,  $0 \leq x \leq a$ ,  $0 \leq y \leq b$ .

17.  $\square C$   $u(x, 0) = 0$ ,  $u(x, b) = f(x)$ ,  $0 < x < a$ ,  
 $u(0, y) = 0$ ,  $u(a, y) = 0$ ,  $0 < y < b$   
 $a = 3$ ,  $b = 2$ ,  $f(x) = x(3 - x)$
18.  $u(x, 0) = f(x)$ ,  $u(x, b) = 0$ ,  $0 < x < a$ ,  
 $u_x(0, y) = 0$ ,  $u_x(a, y) = 0$ ,  $0 < y < b$   
 $a = 2$ ,  $b = 1$ ,  $f(x) = x^2(x - 2)^2$
19.  $u(x, 0) = f(x)$ ,  $u(x, b) = 0$ ,  $0 < x < a$ ,  
 $u_x(0, y) = 0$ ,  $u(a, y) = 0$ ,  $0 < y < b$   
 $a = 1$ ,  $b = 2$ ,  $f(x) = 3x^3 - 4x^2 + 1$
20.  $u(x, 0) = f(x)$ ,  $u(x, b) = 0$ ,  $0 < x < a$ ,  
 $u(0, y) = 0$ ,  $u_x(a, y) = 0$ ,  $0 < y < b$   
 $a = 3$ ,  $b = 2$ ,  $f(x) = x(6 - x)$
21.  $u(x, 0) = f(x)$ ,  $u_y(x, b) = 0$ ,  $0 < x < a$ ,  
 $u(0, y) = 0$ ,  $u(a, y) = 0$ ,  $0 < y < b$   
 $a = \pi$ ,  $b = 2$ ,  $f(x) = x(\pi^2 - x^2)$
22.  $u_y(x, 0) = 0$ ,  $u(x, b) = f(x)$ ,  $0 < x < a$ ,  
 $u_x(0, y) = 0$ ,  $u_x(a, y) = 0$ ,  $0 < y < b$   
 $a = \pi$ ,  $b = 1$ ,  $f(x) = x^2(x - \pi)^2$
23.  $\square C$   $u_y(x, 0) = f(x)$ ,  $u(x, b) = 0$ ,  $0 < x < a$ ,  
 $u(0, y) = 0$ ,  $u(a, y) = 0$ ,  $0 < y < b$   
 $a = \pi$ ,  $b = 1$ ,  $f(x) = \begin{cases} x, & 0 \leq x \leq \frac{\pi}{2}, \\ \pi - x, & \frac{\pi}{2} \leq x \leq \pi \end{cases}$
24.  $u(x, 0) = 0$ ,  $u(x, b) = 0$ ,  $0 < x < a$ ,  
 $u_x(0, y) = 0$ ,  $u(a, y) = g(y)$ ,  $0 < y < b$   
 $a = 1$ ,  $b = 1$ ,  $g(y) = y(y^3 - 2y^2 + 1)$

25.  $\square$   $u_y(x, 0) = 0, \quad u(x, b) = 0, \quad 0 < x < a,$   
 $u_x(0, y) = 0, \quad u(a, y) = g(y), \quad 0 < y < b$   
 $a = 2, \quad b = 2, \quad g(y) = 4 - y^2$
26.  $u(x, 0) = 0, \quad u(x, b) = 0, \quad 0 < x < a,$   
 $u_x(0, y) = 0, \quad u_x(a, y) = g(y), \quad 0 < y < b$   
 $a = 1, \quad b = 4, \quad g(y) = \begin{cases} y, & 0 \leq y \leq 2, \\ 4 - y, & 2 \leq y \leq 4 \end{cases}$
27.  $u(x, 0) = 0, \quad u_y(x, b) = 0, \quad 0 < x < a,$   
 $u_x(0, y) = g(y), \quad u_x(a, y) = 0, \quad 0 < y < b$   
 $a = 1, \quad b = \pi, \quad g(y) = y^2(3\pi - 2y)$
28.  $u_y(x, 0) = 0, \quad u_y(x, b) = 0, \quad 0 < x < a,$   
 $u_x(0, y) = g(y), \quad u(a, y) = 0, \quad 0 < y < b$   
 $a = 2, \quad b = \pi, \quad g(y) = y$

In Exercises 29-34 define the bounded formal solution of

$$u_{xx} + u_{yy} = 0, \quad 0 < x < a, \quad y > 0$$

that satisfies the given boundary conditions for general  $a$  and  $f$ . Then solve the boundary value problem for the specified  $a$  and  $f$ .

29.  $u(x, 0) = f(x), \quad 0 < x < a,$   
 $u_x(0, y) = 0, \quad u_x(a, y) = 0, \quad y > 0$   
 $a = \pi, \quad f(x) = x^2(3\pi - 2x)$
30.  $u(x, 0) = f(x), \quad 0 < x < a,$   
 $u_x(0, y) = 0, \quad u(a, y) = 0, \quad y > 0$   
 $a = 3, \quad f(x) = 9 - x^2$
31.  $u(x, 0) = f(x), \quad 0 < x < a,$   
 $u(0, y) = 0, \quad u_x(a, y) = 0, \quad y > 0$   
 $a = \pi, \quad f(x) = x(2\pi - x)$
32.  $u_y(x, 0) = f(x), \quad 0 < x < a,$   
 $u(0, y) = 0, \quad u(a, y) = 0, \quad y > 0$   
 $a = \pi, \quad f(x) = x^2(\pi - x)$
33.  $u_y(x, 0) = f(x), \quad 0 < x < a,$   
 $u_x(0, y) = 0, \quad u(a, y) = 0, \quad y > 0$   
 $a = 7, \quad f(x) = x(7 - x)$
34.  $u_y(x, 0) = f(x), \quad 0 < x < a,$   
 $u(0, y) = 0, \quad u_x(a, y) = 0, \quad y > 0$   
 $a = 5, \quad f(x) = x(5 - x)$

35. Define the formal solution of the Dirichlet problem

$$u_{xx} + u_{yy} = 0, \quad 0 < x < a, \quad 0 < y < b,$$

$$u(x, 0) = f_0(x), \quad u(x, b) = f_1(x), \quad 0 \leq x \leq a,$$

$$u(0, y) = g_0(y), \quad u(a, y) = g_1(y), \quad 0 \leq y \leq b$$

36. Show that the Neumann Problem

$$u_{xx} + u_{yy} = 0, \quad 0 < x < a, \quad 0 < y < b,$$

$$u_y(x, 0) = f_0(x), \quad u_y(x, b) = f_1(x), \quad 0 \leq x \leq a,$$

$$u_x(0, y) = g_0(y), \quad u_x(a, y) = g_1(y), \quad 0 \leq y \leq b$$

has no solution unless

$$\int_0^a f_0(x) dx = \int_0^a f_1(x) dx = \int_0^b g_0(y) dy = \int_0^b g_1(y) dy = 0.$$

In this case it has infinitely many formal solutions. Find them.

- 37.** In this exercise take it as given that the infinite series  $\sum_{n=1}^{\infty} n^p e^{-qn}$  converges for all  $p$  if  $q > 0$ , and, where appropriate, use the comparison test for absolute convergence of an infinite series.

Let

$$u(x, y) = \sum_{n=1}^{\infty} \alpha_n \frac{\sinh n\pi(b-y)/a}{\sinh n\pi b/a} \sin \frac{n\pi x}{a},$$

where

$$\alpha_n = \frac{2}{a} \int_0^a f(x) \sin \frac{n\pi x}{a} dx$$

and  $f$  is piecewise smooth on  $[0, a]$ .

- (a) Verify the approximations

$$\frac{\sinh n\pi(b-y)/a}{\sinh n\pi b/a} \approx e^{-n\pi y/a}, \quad y < b, \quad (\text{A})$$

and

$$\frac{\cosh n\pi(b-y)/a}{\sinh n\pi b/a} \approx e^{-n\pi y/a}, \quad y < b \quad (\text{B})$$

for large  $n$ .

- (b) Use (A) to show that  $u$  is defined for  $(x, y)$  such that  $0 < y < b$ .  
 (c) For fixed  $y$  in  $(0, b)$ , use (A) and Theorem 12.1.2 with  $z = x$  to show that

$$u_x(x, y) = \frac{\pi}{a} \sum_{n=1}^{\infty} n\alpha_n \frac{\sinh n\pi(b-y)/a}{\sinh n\pi b/a} \cos \frac{n\pi x}{a}, \quad -\infty < x < \infty.$$

- (d) Starting from the result of (b), use (A) and Theorem 12.1.2 with  $z = x$  to show that, for a fixed  $y$  in  $(0, b)$ ,

$$u_{xx}(x, y) = -\frac{\pi^2}{a^2} \sum_{n=1}^{\infty} n^2 \alpha_n \frac{\sinh n\pi(b-y)/a}{\sinh n\pi b/a} \sin \frac{n\pi x}{a}, \quad -\infty < x < \infty.$$

- (e) For fixed but arbitrary  $x$ , use (B) and Theorem 12.1.2 with  $z = y$  to show that

$$u_y(x, y) = -\frac{\pi}{a} \sum_{n=1}^{\infty} n\alpha_n \frac{\cosh n\pi(b-y)/a}{\sinh n\pi b/a} \sin \frac{n\pi x}{a}$$

if  $0 < y_0 < y < b$ , where  $y_0$  is an arbitrary number in  $(0, b)$ . Then argue that since  $y_0$  can be chosen arbitrarily small, the conclusion holds for all  $y$  in  $(0, b)$ .

- (f) Starting from the result of (e), use (A) and Theorem 12.1.2 to show that

$$u_{yy}(x, y) = \frac{\pi^2}{a^2} \sum_{n=1}^{\infty} n^2 \alpha_n \frac{\sinh n\pi(b-y)/a}{\sinh n\pi b/a} \sin \frac{n\pi x}{a}, \quad 0 < y < b.$$



(g) Conclude that  $u$  satisfies Laplace's equation for all  $(x, y)$  such that  $0 < y < b$ .

By repeatedly applying the arguments in (c)–(f), it can be shown that  $u$  can be differentiated term by term any number of times with respect to  $x$  and/or  $y$  if  $0 < y < b$ .

## 12.4 LAPLACE'S EQUATION IN POLAR COORDINATES

In Section 12.3 we solved boundary value problems for Laplace's equation over a rectangle with sides parallel to the  $x, y$ -axes. Now we'll consider boundary value problems for Laplace's equation over regions with boundaries best described in terms of polar coordinates. In this case it's appropriate to regard  $u$  as function of  $(r, \theta)$  and write Laplace's equation in polar form as

$$u_{rr} + \frac{1}{r}u_r + \frac{1}{r^2}u_{\theta\theta} = 0, \quad (12.4.1)$$

where

$$r = \sqrt{x^2 + y^2} \quad \text{and} \quad \theta = \cos^{-1} \frac{x}{r} = \sin^{-1} \frac{y}{r}.$$

We begin with the case where the region is a circular disk with radius  $\rho$ , centered at the origin; that is, we want to define a formal solution of the boundary value problem

$$\begin{aligned} u_{rr} + \frac{1}{r}u_r + \frac{1}{r^2}u_{\theta\theta} &= 0, & 0 < r < \rho, & \quad -\pi \leq \theta < \pi, \\ u(\rho, \theta) &= f(\theta), & -\pi \leq \theta < \pi \end{aligned} \quad (12.4.2)$$

(Figure 12.4.1). Note that (12.4.2) imposes no restriction on  $u(r, \theta)$  when  $r = 0$ . We'll address this question at the appropriate time.

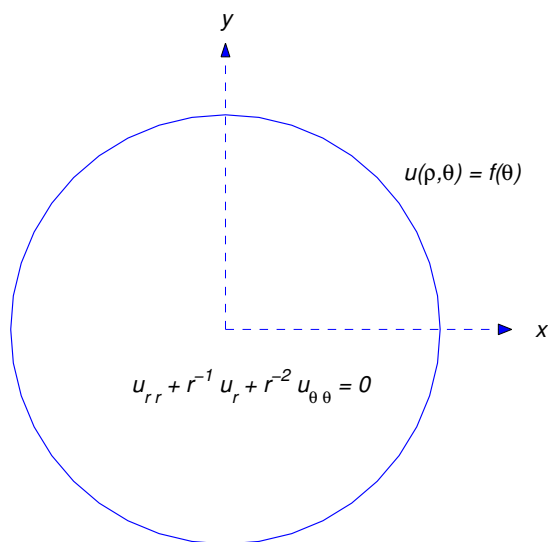

Figure 12.4.1 The boundary value problem (12.4.2)

We first look for products  $v(r, \theta) = R(r)\Theta(\theta)$  that satisfy (12.4.1). For this function,

$$v_{rr} + \frac{1}{r}v_r + \frac{1}{r^2}v_{\theta\theta} = R''\Theta + \frac{1}{r}R'\Theta + \frac{1}{r^2}R\Theta'' = 0$$

for all  $(r, \theta)$  with  $r \neq 0$  if

$$\frac{r^2R'' + rR'}{R} = -\frac{\Theta''}{\Theta} = \lambda,$$

where  $\lambda$  is a separation constant. (Verify.) This equation is equivalent to

$$\Theta'' + \lambda\Theta = 0$$

and

$$r^2R'' + rR' - \lambda R = 0. \quad (12.4.3)$$

Since  $(r, \pi)$  and  $(r, -\pi)$  are the polar coordinates of the same point, we impose periodic boundary conditions on  $\Theta$ ; that is,

$$\Theta'' + \lambda\Theta = 0, \quad \Theta(-\pi) = \Theta(\pi), \quad \Theta'(-\pi) = \Theta'(\pi). \quad (12.4.4)$$

Since we don't want  $R\Theta$  to be identically zero,  $\lambda$  must be an eigenvalue of (12.4.4) and  $\Theta$  must be an associated eigenfunction. From Theorem 11.1.6, the eigenvalues of (12.4.4) are  $\lambda_0 = 0$  with associated eigenfunctions  $\Theta_0 = 1$  and, for  $n = 1, 2, 3, \dots$ ,  $\lambda_n = n^2$ , with associated eigenfunction  $\cos n\theta$  and  $\sin n\theta$  therefore,

$$\Theta_n = \alpha_n \cos n\theta + \beta_n \sin n\theta$$

where  $\alpha_n$  and  $\beta_n$  are constants.

Substituting  $\lambda = 0$  into (12.4.3) yields the

$$r^2R'' + rR' = 0,$$

so

$$\frac{R_0''}{R_0'} = -\frac{1}{r},$$

$$R_0' = \frac{c_1}{r},$$

and

$$R_0 = c_2 + c_1 \ln r. \quad (12.4.5)$$

If  $c_1 \neq 0$  then

$$\lim_{r \rightarrow 0^+} |R_0(r)| = \infty,$$

which doesn't make sense if we interpret  $u_0(r, \theta) = R_0(r)\Theta_0(\theta) = R_0(r)$  as the steady state temperature distribution in a disk whose boundary is maintained at the constant temperature  $R_0(\rho)$ . Therefore we now require  $R_0$  to be bounded as  $r \rightarrow 0^+$ . This implies that  $c_1 = 0$ , and we take  $c_2 = 1$ . Thus,  $R_0 = 1$  and  $v_0(r, \theta) = R_0(r)\Theta_0(\theta) = 1$ . Note that  $v_0$  satisfies (12.4.2) with  $f(\theta) = 1$ .

Substituting  $\lambda = n^2$  into (12.4.3) yields the Euler equation

$$r^2R_n'' + rR_n' - n^2R_n = 0 \quad (12.4.6)$$

for  $R_n$ . The indicial polynomial of this equation is

$$s(s-1) + s - n^2 = (s-n)(s+n),$$

so the general solution of (12.4.6) is

$$R_n = c_1 r^n + c_2 r^{-n}, \quad (12.4.7)$$

by Theorem 7.4.3. Consistent with our previous assumption on  $R_0$ , we now require  $R_n$  to be bounded as  $r \rightarrow 0+$ . This implies that  $c_2 = 0$ , and we choose  $c_1 = \rho^{-n}$ . Then  $R_n(r) = r^n/\rho^n$ , so

$$v_n(r, \theta) = R_n(r)\Theta_n(\theta) = \frac{r^n}{\rho^n}(\alpha_n \cos n\theta + \beta_n \sin n\theta).$$

Now  $v_n$  satisfies (12.4.2) with

$$f(\theta) = \alpha_n \cos n\theta + \beta_n \sin n\theta.$$

More generally, if  $\alpha_0, \alpha_1, \dots, \alpha_m$  and  $\beta_1, \beta_2, \dots, \beta_m$  are arbitrary constants then

$$u_m(r, \theta) = \alpha_0 + \sum_{n=1}^m \frac{r^n}{\rho^n}(\alpha_n \cos n\theta + \beta_n \sin n\theta)$$

satisfies (12.4.2) with

$$f(\theta) = \alpha_0 + \sum_{n=1}^m (\alpha_n \cos n\theta + \beta_n \sin n\theta).$$

This motivates the next definition.

**Definition 12.4.1** The bounded formal solution of the boundary value problem (12.4.2) is

$$u(r, \theta) = \alpha_0 + \sum_{n=1}^{\infty} \frac{r^n}{\rho^n}(\alpha_n \cos n\theta + \beta_n \sin n\theta), \quad (12.4.8)$$

where

$$F(\theta) = \alpha_0 + \sum_{n=1}^{\infty} (\alpha_n \cos n\theta + \beta_n \sin n\theta)$$

is the Fourier series of  $f$  on  $[-\pi, \pi]$ ; that is,

$$\alpha_0 = \frac{1}{2\pi} \int_{-\pi}^{\pi} f(\theta) d\theta,$$

and

$$\alpha_n = \frac{1}{\pi} \int_{-\pi}^{\pi} f(\theta) \cos n\theta d\theta \quad \text{and} \quad \beta_n = \frac{1}{\pi} \int_{-\pi}^{\pi} f(\theta) \sin n\theta d\theta, \quad n = 1, 2, 3, \dots$$

Since  $\sum_{n=0}^{\infty} n^k (r/\rho)^n$  converges for every  $k$  if  $0 < r < \rho$ , Theorem 12.1.2 can be used to show that if  $0 < r < \rho$  then (12.4.8) can be differentiated term by term any number of times with respect to both  $r$  and  $\theta$ . Since the terms in (12.4.8) satisfy Laplace's equation if  $r > 0$ , (12.4.8) satisfies Laplace's equation if  $0 < r < \rho$ . Therefore, since  $u(\rho, \theta) = F(\theta)$ ,  $u$  is an actual solution of (12.4.2) if and only if

$$F(\theta) = f(\theta), \quad -\pi \leq \theta < \pi.$$

From Theorem 11.2.4, this is true if  $f$  is continuous and piecewise smooth on  $[-\pi, \pi]$  and  $f(-\pi) = f(\pi)$ .

**Example 12.4.1** Find the bounded formal solution of (12.4.2) with  $f(\theta) = \theta(\pi^2 - \theta^2)$ .

**Solution** From Example 11.2.6,

$$\theta(\pi^2 - \theta^2) = 12 \sum_{n=1}^{\infty} \frac{(-1)^n}{n^3} \sin n\theta, \quad -\pi \leq \theta \leq \pi,$$

so

$$u(r, \theta) = 12 \sum_{n=1}^{\infty} \frac{r^n}{\rho^n} \frac{(-1)^n}{n^3} \sin n\theta, \quad 0 \leq r \leq \rho, \quad -\pi \leq \theta \leq \pi.$$

**Example 12.4.2** Define the formal solution of

$$\begin{aligned} u_{rr} + \frac{1}{r}u_r + \frac{1}{r^2}u_{\theta\theta} &= 0, & \rho_0 < r < \rho, & \quad -\pi \leq \theta < \pi, \\ u(\rho_0, \theta) &= 0, & u(\rho, \theta) &= f(\theta), & \quad -\pi \leq \theta < \pi, \end{aligned} \tag{12.4.9}$$

where  $0 < \rho_0 < \rho$  (Figure 12.4.2).

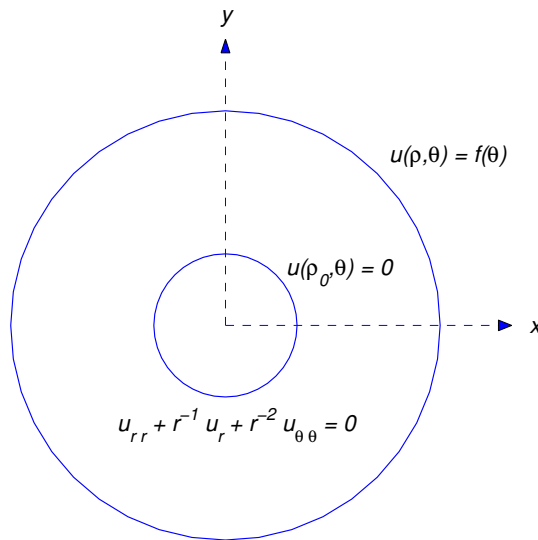

Figure 12.4.2 The boundary value problem (12.4.9)

**Solution** We use separation of variables exactly as before, except that now we choose the constants in (12.4.5) and (12.4.7) so that  $R_n(\rho_0) = 0$  for  $n = 0, 1, 2, \dots$ . In view of the nonhomogeneous Dirichlet condition on the boundary  $r = \rho$ , it's also convenient to require that  $R_n(\rho) = 1$  for  $n = 0, 1, 2, \dots$ . We leave it to you to verify that

$$R_0(r) = \frac{\ln r/\rho_0}{\ln \rho/\rho_0} \quad \text{and} \quad R_n = \frac{\rho_0^{-n}r^n - \rho_0^n r^{-n}}{\rho_0^{-n}\rho^n - \rho_0^n\rho^{-n}}, \quad n = 1, 2, 3, \dots$$

satisfy these requirements. Therefore

$$v_0(\rho, \theta) = \frac{\ln r/\rho_0}{\ln \rho/\rho_0}$$

and

$$v_n(r, \theta) = \frac{\rho_0^{-n}r^n - \rho_0^n r^{-n}}{\rho_0^{-n}\rho^n - \rho_0^n\rho^{-n}}(\alpha_n \cos n\theta + \beta_n \sin n\theta), \quad n = 1, 2, 3, \dots,$$

where  $\alpha_n$  and  $\beta_n$  are arbitrary constants.

If  $\alpha_0, \alpha_1, \dots, \alpha_m$  and  $\beta_1, \beta_2, \dots, \beta_m$  are arbitrary constants then

$$u_m(r, \theta) = \alpha_0 \frac{\ln r/\rho_0}{\ln \rho/\rho_0} + \sum_{n=1}^m \frac{\rho_0^{-n}r^n - \rho_0^n r^{-n}}{\rho_0^{-n}\rho^n - \rho_0^n\rho^{-n}}(\alpha_n \cos n\theta + \beta_n \sin n\theta)$$

satisfies (12.4.9), with

$$f(\theta) = \alpha_0 + \sum_{n=1}^m (\alpha_n \cos n\theta + \beta_n \sin n\theta).$$

This motivates us to define the formal solution of (12.4.9) for general  $f$  to be

$$u(r, \theta) = \alpha_0 \frac{\ln r/\rho_0}{\ln \rho/\rho_0} + \sum_{n=1}^{\infty} \frac{\rho_0^{-n}r^n - \rho_0^n r^{-n}}{\rho_0^{-n}\rho^n - \rho_0^n\rho^{-n}}(\alpha_n \cos n\theta + \beta_n \sin n\theta),$$

where

$$F(\theta) = \alpha_0 + \sum_{n=1}^{\infty} (\alpha_n \cos n\theta + \beta_n \sin n\theta)$$

is the Fourier series of  $f$  on  $[-\pi, \pi]$ .

**Example 12.4.3** Define the bounded formal solution of

$$\begin{aligned} u_{rr} + \frac{1}{r}u_r + \frac{1}{r^2}u_{\theta\theta} &= 0, & 0 < r < \rho, & \quad 0 < \theta < \gamma, \\ u(\rho, \theta) &= f(\theta), & 0 &\leq \theta \leq \gamma, \\ u(r, 0) &= 0, \quad u(r, \gamma) = 0, & 0 < r < \rho, \end{aligned} \tag{12.4.10}$$

where  $0 < \gamma < 2\pi$  (Figure 12.4.3).

**Solution** Now  $v(r, \theta) = R(r)\Theta(\theta)$ , where

$$r^2R'' + rR' - \lambda R = 0 \tag{12.4.11}$$

and

$$\Theta'' + \lambda\Theta = 0, \quad \Theta(0) = 0, \quad \Theta(\gamma) = 0. \tag{12.4.12}$$

From Theorem 11.1.2, the eigenvalues of (12.4.12) are  $\lambda_n = n^2\pi^2/\gamma^2$ , with associated eigenfunction  $\Theta_n = \sin n\pi\theta/\gamma$ ,  $n = 1, 2, 3, \dots$ . Substituting  $\lambda = n^2\pi^2/\gamma^2$  into (12.4.11) yields the Euler equation

$$r^2R'' + rR'_n - \frac{n^2\pi^2}{\gamma^2}R = 0.$$

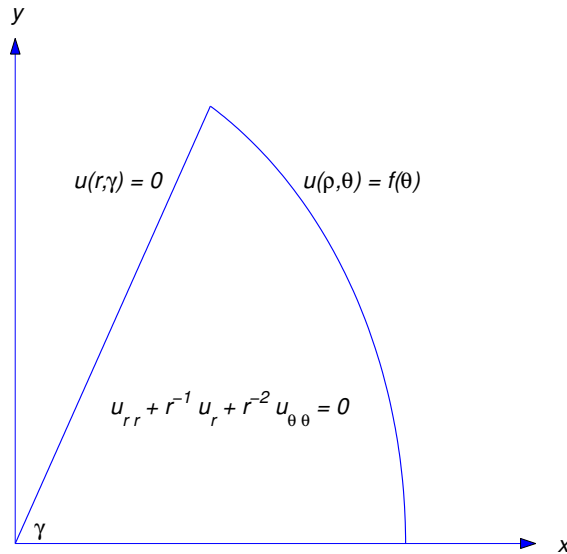

Figure 12.4.3 The boundary value problem (12.4.10)

The indicial polynomial of this equation is

$$s(s - 1) + s - \frac{n^2 \pi^2}{\gamma^2} = \left( s - \frac{n\pi}{\gamma} \right) \left( s + \frac{n\pi}{\gamma} \right),$$

so

$$R_n = c_1 r^{n\pi/\gamma} + c_2 r^{-n\pi/\gamma},$$

by Theorem 7.4.3. To obtain a solution that remains bounded as  $r \rightarrow 0+$  we let  $c_2 = 0$ . Because of the Dirichlet condition at  $r = \rho$ , it's convenient to have  $r(\rho) = 1$ ; therefore we take  $c_1 = \rho^{-n\pi/\gamma}$ , so

$$R_n(r) = \frac{r^{n\pi/\gamma}}{\rho^{n\pi/\gamma}}.$$

Now

$$v_n(r, \theta) = R_n(r)\Theta_n(\theta) = \frac{r^{n\pi/\gamma}}{\rho^{n\pi/\gamma}} \sin \frac{n\pi\theta}{\gamma}$$

satisfies (12.4.10) with

$$f(\theta) = \sin \frac{n\pi\theta}{\gamma}.$$

More generally, if  $\alpha_1, \alpha_2, \dots, \alpha_m$  and are arbitrary constants then

$$u_m(r, \theta) = \sum_{n=1}^m \alpha_n \frac{r^{n\pi/\gamma}}{\rho^{n\pi/\gamma}} \sin \frac{n\pi\theta}{\gamma}$$

satisfies (12.4.10) with

$$f(\theta) = \sum_{n=1}^m \alpha_n \sin \frac{n\pi\theta}{\gamma}.$$

This motivates us to define the bounded formal solution of (12.4.10) to be

$$u_m(r, \theta) = \sum_{n=1}^{\infty} \alpha_n \frac{r^{n\pi/\gamma}}{\rho^{n\pi/\gamma}} \sin \frac{n\pi\theta}{\gamma},$$

where

$$S(\theta) = \sum_{n=1}^{\infty} \alpha_n \sin \frac{n\pi\theta}{\gamma}$$

is the Fourier sine expansion of  $f$  on  $[0, \gamma]$ ; that is,

$$\alpha_n = \frac{2}{\gamma} \int_0^{\gamma} f(\theta) \sin \frac{n\pi\theta}{\gamma} d\theta.$$

## 12.4 Exercises

---

1. Define the formal solution of

$$\begin{aligned} u_{rr} + \frac{1}{r}u_r + \frac{1}{r^2}u_{\theta\theta} &= 0, & \rho_0 < r < \rho, & & -\pi \leq \theta < \pi, \\ u(\rho_0, \theta) &= f(\theta), & u(\rho, \theta) &= 0, & -\pi \leq \theta < \pi, \end{aligned}$$

where  $0 < \rho_0 < \rho$ .

2. Define the formal solution of

$$\begin{aligned} u_{rr} + \frac{1}{r}u_r + \frac{1}{r^2}u_{\theta\theta} &= 0, & \rho_0 < r < \rho, & & 0 < \theta < \gamma, \\ u(\rho_0, \theta) &= 0, & u(\rho, \theta) &= f(\theta), & 0 \leq \theta \leq \gamma, \\ u(r, 0) &= 0, & u(r, \gamma) &= 0, & \rho_0 < r < \rho, \end{aligned}$$

where  $0 < \gamma < 2\pi$  and  $0 < \rho_0 < \rho$ .

3. Define the formal solution of

$$\begin{aligned} u_{rr} + \frac{1}{r}u_r + \frac{1}{r^2}u_{\theta\theta} &= 0, & \rho_0 < r < \rho, & & 0 < \theta < \gamma, \\ u(\rho_0, \theta) &= 0, & u_r(\rho, \theta) &= g(\theta), & 0 \leq \theta \leq \gamma, \\ u_{\theta}(r, 0) &= 0, & u_{\theta}(r, \gamma) &= 0, & \rho_0 < r < \rho, \end{aligned}$$

where  $0 < \gamma < 2\pi$  and  $0 < \rho_0 < \rho$ .

4. Define the bounded formal solution of

$$\begin{aligned} u_{rr} + \frac{1}{r}u_r + \frac{1}{r^2}u_{\theta\theta} &= 0, & 0 < r < \rho, & & 0 < \theta < \gamma, \\ u(\rho, \theta) &= f(\theta), & 0 \leq \theta \leq \gamma, & & \\ u_{\theta}(r, 0) &= 0, & u(r, \gamma) &= 0, & 0 < r < \rho, \end{aligned}$$

where  $0 < \gamma < 2\pi$ .

5. Define the formal solution of

$$\begin{aligned} u_{rr} + \frac{1}{r}u_r + \frac{1}{r^2}u_{\theta\theta} &= 0, & \rho_0 < r < \rho, & \quad 0 < \theta < \gamma, \\ u_r(\rho_0, \theta) &= g(\theta), & u_r(\rho, \theta) &= 0, & \quad 0 \leq \theta \leq \gamma, \\ u(r, 0) &= 0, & u_\theta(r, \gamma) &= 0, & \quad \rho_0 < r < \rho, \end{aligned}$$

where  $0 < \gamma < 2\pi$  and  $0 < \rho_0 < \rho$ .

6. Define the bounded formal solution of

$$\begin{aligned} u_{rr} + \frac{1}{r}u_r + \frac{1}{r^2}u_{\theta\theta} &= 0, & 0 < r < \rho, & \quad 0 < \theta < \gamma, \\ u(\rho, \theta) &= f(\theta), & 0 \leq \theta \leq \gamma, \\ u_\theta(r, 0) &= 0, & u_\theta(r, \gamma) &= 0, & \quad 0 < r < \rho, \end{aligned}$$

where  $0 < \gamma < 2\pi$ .

7. Show that the Neumann problem

$$\begin{aligned} u_{rr} + \frac{1}{r}u_r + \frac{1}{r^2}u_{\theta\theta} &= 0, & 0 < r < \rho, & \quad -\pi \leq \theta < \pi, \\ u_r(\rho, \theta) &= f(\theta), & -\pi \leq \theta < \pi \end{aligned}$$

has no bounded formal solution unless  $\int_{-\pi}^{\pi} f(\theta) d\theta = 0$ . In this case it has infinitely many solutions. Find those solutions.





# **CHAPTER 13**

## **Boundary Value Problems for Second Order Ordinary Differential Equations**

IN THIS CHAPTER we discuss boundary value problems and eigenvalue problems for linear second order ordinary differential equations.

Section 13.1 discusses point two-point boundary value problems for linear second order ordinary differential equations.

Section 13.2 deals with generalizations of the eigenvalue problems considered in Section 11.1

### 13.1 TWO-POINT BOUNDARY VALUE PROBLEMS

In Section 5.3 we considered initial value problems for the linear second order equation

$$P_0(x)y'' + P_1(x)y' + P_2(x)y = F(x). \quad (13.1.1)$$

Suppose  $P_0, P_1, P_2,$  and  $F$  are continuous and  $P_0$  has no zeros on an open interval  $(a, b)$ . From Theorem 5.3.1, if  $x_0$  is in  $(a, b)$  and  $k_1$  and  $k_2$  are arbitrary real numbers then (13.1.1) has a unique solution on  $(a, b)$  such that  $y(x_0) = k_1$  and  $y'(x_0) = k_2$ . Now we consider a different problem for (13.1.1).

**PROBLEM** Suppose  $P_0, P_1, P_2,$  and  $F$  are continuous and  $P_0$  has no zeros on a closed interval  $[a, b]$ . Let  $\alpha, \beta, \rho,$  and  $\delta$  be real numbers such that

$$\alpha^2 + \beta^2 \neq 0 \quad \text{and} \quad \rho^2 + \delta^2 \neq 0, \quad (13.1.2)$$

and let  $k_1$  and  $k_2$  be arbitrary real numbers. Find a solution of

$$P_0(x)y'' + P_1(x)y' + P_2(x)y = F(x) \quad (13.1.3)$$

on the closed interval  $[a, b]$  such that

$$\alpha y(a) + \beta y'(a) = k_1 \quad (13.1.4)$$

and

$$\rho y(b) + \delta y'(b) = k_2. \quad (13.1.5)$$

The assumptions stated in this problem apply throughout this section and won't be repeated. Note that we imposed conditions on  $P_0, P_1, P_2,$  and  $F$  on the *closed* interval  $[a, b]$ , and we are interested in solutions of (13.1.3) on the closed interval. This is different from the situation considered in Chapter 5, where we imposed conditions on  $P_0, P_1, P_2,$  and  $F$  on the *open* interval  $(a, b)$  and we were interested in solutions on the open interval. There is really no problem here; we can always extend  $P_0, P_1, P_2,$  and  $F$  to an open interval  $(c, d)$  (for example, by defining them to be constant on  $(c, d]$  and  $[b, d)$ ) so that they are continuous and  $P_0$  has no zeros on  $[c, d]$ . Then we can apply the theorems from Chapter 5 to the equation

$$y'' + \frac{P_1(x)}{P_0(x)}y' + \frac{P_2(x)}{P_0(x)}y = \frac{F(x)}{P_0(x)}$$

on  $(c, d)$  to draw conclusions about solutions of (13.1.3) on  $[a, b]$ .

We call  $a$  and  $b$  *boundary points*. The conditions (13.1.4) and (13.1.5) are *boundary conditions*, and the problem is a *two-point boundary value problem* or, for simplicity, a *boundary value problem*. (We used similar terminology in Chapter 12 with a different meaning; both meanings are in common usage.) We require (13.1.2) to insure that we're imposing a sensible condition at each boundary point. For example, if  $\alpha^2 + \beta^2 = 0$  then  $\alpha = \beta = 0$ , so  $\alpha y(a) + \beta y'(a) = 0$  for all choices of  $y(a)$  and  $y'(a)$ . Therefore (13.1.4) is an impossible condition if  $k_1 \neq 0$ , or no condition at all if  $k_1 = 0$ .

We abbreviate (13.1.1) as  $Ly = F$ , where

$$Ly = P_0(x)y'' + P_1(x)y' + P_2(x)y,$$

and we denote

$$B_1(y) = \alpha y(a) + \beta y'(a) \quad \text{and} \quad B_2(y) = \rho y(b) + \delta y'(b).$$

We combine (13.1.3), (13.1.4), and (13.1.5) as

$$Ly = F, \quad B_1(y) = k_1, \quad B_2(y) = k_2. \quad (13.1.6)$$

This boundary value problem is *homogeneous* if  $F = 0$  and  $k_1 = k_2 = 0$ ; otherwise it's *nonhomogeneous*.

We leave it to you (Exercise 1) to verify that  $B_1$  and  $B_2$  are linear operators; that is, if  $c_1$  and  $c_2$  are constants then

$$B_i(c_1 y_1 + c_2 y_2) = c_1 B_i(y_1) + c_2 B_i(y_2), \quad i = 1, 2. \quad (13.1.7)$$

The next three examples show that the question of existence and uniqueness for solutions of boundary value problems is more complicated than for initial value problems.

**Example 13.1.1** Consider the boundary value problem

$$y'' + y = 1, \quad y(0) = 0, \quad y(\pi/2) = 0.$$

The general solution of  $y'' + y = 1$  is

$$y = 1 + c_1 \sin x + c_2 \cos x,$$

so  $y(0) = 0$  if and only if  $c_2 = -1$  and  $y(\pi/2) = 0$  if and only if  $c_1 = -1$ . Therefore

$$y = 1 - \sin x - \cos x$$

is the unique solution of the boundary value problem.

**Example 13.1.2** Consider the boundary value problem

$$y'' + y = 1, \quad y(0) = 0, \quad y(\pi) = 0.$$

Again, the general solution of  $y'' + y = 1$  is

$$y = 1 + c_1 \sin x + c_2 \cos x,$$

so  $y(0) = 0$  if and only if  $c_2 = -1$ , but  $y(\pi) = 0$  if and only if  $c_2 = 1$ . Therefore the boundary value problem has no solution.

**Example 13.1.3** Consider the boundary value problem

$$y'' + y = \sin 2x, \quad y(0) = 0, \quad y(\pi) = 0.$$

You can use the method of undetermined coefficients (Section 5.5) to find that the general solution of  $y'' + y = \sin 2x$  is

$$y = -\frac{\sin 2x}{3} + c_1 \sin x + c_2 \cos x.$$

The boundary conditions  $y(0) = 0$  and  $y(\pi) = 0$  both require that  $c_2 = 0$ , but they don't restrict  $c_1$ . Therefore the boundary value problem has infinitely many solutions

$$y = -\frac{\sin 2x}{3} + c_1 \sin x,$$

where  $c_1$  is arbitrary.

**Theorem 13.1.1** *If  $z_1$  and  $z_2$  are solutions of  $Ly = 0$  such that either  $B_1(z_1) = B_1(z_2) = 0$  or  $B_2(z_1) = B_2(z_2) = 0$ , then  $\{z_1, z_2\}$  is linearly dependent. Equivalently, if  $\{z_1, z_2\}$  is linearly independent, then*

$$B_1^2(z_1) + B_1^2(z_2) \neq 0 \quad \text{and} \quad B_2^2(z_1) + B_2^2(z_2) \neq 0.$$

**Proof** Recall that  $B_1(z) = \alpha z(a) + \beta z'(a)$  and  $\alpha^2 + \beta^2 \neq 0$ . Therefore, if  $B_1(z_1) = B_1(z_2) = 0$  then  $(\alpha, \beta)$  is a nontrivial solution of the system

$$\begin{aligned}\alpha z_1(a) + \beta z_1'(a) &= 0 \\ \alpha z_2(a) + \beta z_2'(a) &= 0.\end{aligned}$$

This implies that

$$z_1(a)z_2'(a) - z_1'(a)z_2(a) = 0,$$

so  $\{z_1, z_2\}$  is linearly dependent, by Theorem 5.1.6. We leave it to you to show that  $\{z_1, z_2\}$  is linearly dependent if  $B_2(z_1) = B_2(z_2) = 0$ .

**Theorem 13.1.2** *The following statements are equivalent; that is, they are either all true or all false.*

(a) *There's a fundamental set  $\{z_1, z_2\}$  of solutions of  $Ly = 0$  such that*

$$B_1(z_1)B_2(z_2) - B_1(z_2)B_2(z_1) \neq 0. \quad (13.1.8)$$

(b) *If  $\{y_1, y_2\}$  is a fundamental set of solutions of  $Ly = 0$  then*

$$B_1(y_1)B_2(y_2) - B_1(y_2)B_2(y_1) \neq 0. \quad (13.1.9)$$

(c) *For each continuous  $F$  and pair of constants  $(k_1, k_2)$ , the boundary value problem*

$$Ly = F, \quad B_1(y) = k_1, \quad B_2(y) = k_2$$

*has a unique solution.*

(d) *The homogeneous boundary value problem*

$$Ly = 0, \quad B_1(y) = 0, \quad B_2(y) = 0 \quad (13.1.10)$$

*has only the trivial solution  $y = 0$ .*

(e) *The homogeneous equation  $Ly = 0$  has linearly independent solutions  $z_1$  and  $z_2$  such that  $B_1(z_1) = 0$  and  $B_2(z_2) = 0$ .*

**Proof** We'll show that

$$(a) \implies (b) \implies (c) \implies (d) \implies (e) \implies (a).$$

(a)  $\implies$  (b): Since  $\{z_1, z_2\}$  is a fundamental set of solutions for  $Ly = 0$ , there are constants  $a_1, a_2, b_1,$  and  $b_2$  such that

$$\begin{aligned}y_1 &= a_1 z_1 + a_2 z_2 \\ y_2 &= b_1 z_1 + b_2 z_2.\end{aligned} \quad (13.1.11)$$

Moreover,

$$\begin{vmatrix} a_1 & a_2 \\ b_1 & b_2 \end{vmatrix} \neq 0. \quad (13.1.12)$$

because if this determinant were zero, its rows would be linearly dependent and therefore  $\{y_1, y_2\}$  would be linearly dependent, contrary to our assumption that  $\{y_1, y_2\}$  is a fundamental set of solutions of  $Ly = 0$ . From (13.1.7) and (13.1.11),

$$\begin{bmatrix} B_1(y_1) & B_2(y_1) \\ B_1(y_2) & B_2(y_2) \end{bmatrix} = \begin{bmatrix} a_1 & a_2 \\ b_1 & b_2 \end{bmatrix} \begin{bmatrix} B_1(z_1) & B_2(z_1) \\ B_1(z_2) & B_2(z_2) \end{bmatrix}.$$

Since the determinant of a product of matrices is the product of the determinants of the matrices, (13.1.8) and (13.1.12) imply (13.1.9).

(b)  $\implies$  (c): Since  $\{y_1, y_2\}$  is a fundamental set of solutions of  $Ly = 0$ , the general solution of  $Ly = F$  is

$$y = y_p + c_1 y_1 + c_2 y_2,$$

where  $c_1$  and  $c_2$  are arbitrary constants and  $y_p$  is a particular solution of  $Ly = F$ . To satisfy the boundary conditions, we must choose  $c_1$  and  $c_2$  so that

$$\begin{aligned} k_1 &= B_1(y_p) + c_1 B_1(y_1) + c_2 B_1(y_2) \\ k_2 &= B_2(y_p) + c_1 B_2(y_1) + c_2 B_2(y_2), \end{aligned}$$

(recall (13.1.7)), which is equivalent to

$$\begin{aligned} c_1 B_1(y_1) + c_2 B_1(y_2) &= k_1 - B_1(y_p) \\ c_1 B_2(y_1) + c_2 B_2(y_2) &= k_2 - B_2(y_p). \end{aligned}$$

From (13.1.9), this system always has a unique solution  $(c_1, c_2)$ .

(c)  $\implies$  (d): Obviously,  $y = 0$  is a solution of (13.1.10). From (c) with  $F = 0$  and  $k_1 = k_2 = 0$ , it's the only solution.

(d)  $\implies$  (e): Let  $\{y_1, y_2\}$  be a fundamental system for  $Ly = 0$  and let

$$z_1 = B_1(y_2)y_1 - B_1(y_1)y_2 \quad \text{and} \quad z_2 = B_2(y_2)y_1 - B_2(y_1)y_2.$$

Then  $B_1(z_1) = 0$  and  $B_2(z_2) = 0$ . To see that  $z_1$  and  $z_2$  are linearly independent, note that

$$\begin{aligned} a_1 z_1 + a_2 z_2 &= a_1 [B_1(y_2)y_1 - B_1(y_1)y_2] + a_2 [B_2(y_2)y_1 - B_2(y_1)y_2] \\ &= [B_1(y_2)a_1 + B_2(y_2)a_2]y_1 - [B_1(y_1)a_1 + B_2(y_1)a_2]y_2. \end{aligned}$$

Therefore, since  $y_1$  and  $y_2$  are linearly independent,  $a_1 z_1 + a_2 z_2 = 0$  if and only if

$$\begin{bmatrix} B_1(y_1) & B_2(y_1) \\ B_1(y_2) & B_2(y_2) \end{bmatrix} \begin{bmatrix} a_1 \\ a_2 \end{bmatrix} = \begin{bmatrix} 0 \\ 0 \end{bmatrix}.$$

If this system has a nontrivial solution then so does the system

$$\begin{bmatrix} B_1(y_1) & B_1(y_2) \\ B_2(y_1) & B_2(y_2) \end{bmatrix} \begin{bmatrix} c_1 \\ c_2 \end{bmatrix} = \begin{bmatrix} 0 \\ 0 \end{bmatrix}.$$

This and (13.1.7) imply that  $y = c_1 z_1 + c_2 z_2$  is a nontrivial solution of (13.1.10), which contradicts (d).

(e)  $\implies$  (a). Theorem 13.1.1 implies that if  $B_1(z_1) = 0$  and  $B_2(z_2) = 0$  then  $B_1(z_2) \neq 0$  and  $B_2(z_1) \neq 0$ . This implies (13.1.8), which completes the proof.

**Example 13.1.4** Solve the boundary value problem

$$x^2 y'' - 2xy' + 2y - 2x^3 = 0, \quad y(1) = 4, \quad y'(2) = 3, \quad (13.1.13)$$

given that  $\{x, x^2\}$  is a fundamental set of solutions of the complementary equation

**Solution** Using variation of parameters (Section 5.7), you can show that  $y_p = x^3$  is a solution of the complementary equation

$$x^2 y'' - 2xy' + 2y = 2x^3 = 0.$$

Therefore the solution of (13.1.13) can be written as

$$y = x^3 + c_1x + c_2x^2.$$

Then

$$y' = 3x^2 + c_1 + 2c_2x,$$

and imposing the boundary conditions yields the system

$$\begin{aligned} c_1 + c_2 &= 3 \\ c_1 + 4c_2 &= -9, \end{aligned}$$

so  $c_1 = 7$  and  $c_2 = -4$ . Therefore

$$y = x^3 + 7x - 4x^2$$

is the unique solution of (13.1.13)

**Example 13.1.5** Solve the boundary value problem

$$y'' - 7y' + 12y = 4e^{2x}, \quad y(0) = 3, \quad y(1) = 5e^2.$$

**Solution** From Example 5.4.1,  $y_p = 2e^{2x}$  is a particular solution of

$$y'' - 7y' + 12y = 4e^{2x}. \quad (13.1.14)$$

Since  $\{e^{3x}, e^{4x}\}$  is a fundamental set for the complementary equation, we could write the solution of (13.1.13) as

$$y = 2e^{2x} + c_1e^{3x} + c_2e^{4x}$$

and determine  $c_1$  and  $c_2$  by imposing the boundary conditions. However, this would lead to some tedious algebra, and the form of the solution would be very unappealing. (Try it!) In this case it's convenient to use the fundamental system  $\{z_1, z_2\}$  mentioned in Theorem 13.1.2(e); that is, we choose  $\{z_1, z_2\}$  so that  $B_1(z_1) = z_1(0) = 0$  and  $B_2(z_2) = z_2(1) = 0$ . It is easy to see that

$$z_1 = e^{3x} - e^{4x} \quad \text{and} \quad z_2 = e^{3(x-1)} - e^{4(x-1)}$$

satisfy these requirements. Now we write the solution of (13.1.14) as

$$y = 2e^{2x} + c_1(e^{3x} - e^{4x}) + c_2(e^{3(x-1)} - e^{4(x-1)}).$$

Imposing the boundary conditions  $y(0) = 3$  and  $y(1) = 5e^2$  yields

$$3 = 2 + c_2e^{-4}(e - 1) \quad \text{and} \quad 5e^2 = 2e^2 + c_1e^3(1 - e).$$

Therefore

$$c_1 = \frac{3}{e(1 - e)}, \quad c_2 = \frac{e^4}{e - 1},$$

and

$$y = 2e^{2x} + \frac{3}{e(1 - e)}(e^{3x} - e^{4x}) + \frac{e^4}{e - 1}(e^{3(x-1)} - e^{4(x-1)}).$$

Sometimes it's useful to have a formula for the solution of a general boundary problem. Our next theorem addresses this question.

**Theorem 13.1.3** *Suppose the homogeneous boundary value problem*

$$Ly = 0, \quad B_1(y) = 0, \quad B_2(y) = 0 \quad (13.1.15)$$

*has only the trivial solution. Let  $y_1$  and  $y_2$  be linearly independent solutions of  $Ly = 0$  such that  $B_1(y_1) = 0$  and  $B_2(y_2) = 0$ , and let*

$$W = y_1 y_2' - y_1' y_2.$$

*Then the unique solution of*

$$Ly = F, \quad B_1(y) = 0, \quad B_2(y) = 0 \quad (13.1.16)$$

*is*

$$y(x) = y_1(x) \int_x^b \frac{F(t)y_2(t)}{P_0(t)W(t)} dt + y_2(x) \int_a^x \frac{F(t)y_1(t)}{P_0(t)W(t)} dt. \quad (13.1.17)$$

**Proof** In Section 5.7 we saw that if

$$y = u_1 y_1 + u_2 y_2 \quad (13.1.18)$$

where

$$\begin{aligned} u_1' y_1 + u_2' y_2 &= 0 \\ u_1' y_1' + u_2' y_2' &= F, \end{aligned}$$

then  $Ly = F$ . Solving for  $u_1'$  and  $u_2'$  yields

$$u_1' = -\frac{F y_2}{P_0 W} \quad \text{and} \quad u_2' = \frac{F y_1}{P_0 W},$$

which hold if

$$u_1(x) = \int_x^b \frac{F(t)y_2(t)}{P_0(t)W(t)} dt \quad \text{and} \quad u_2(x) = \int_a^x \frac{F(t)y_1(t)}{P_0(t)W(t)} dt.$$

This and (13.1.18) show that (13.1.17) is a solution of  $Ly = F$ . Differentiating (13.1.17) yields

$$y'(x) = y_1'(x) \int_x^b \frac{F(t)y_2(t)}{P_0(t)W(t)} dt + y_2'(x) \int_a^x \frac{F(t)y_1(t)}{P_0(t)W(t)} dt. \quad (13.1.19)$$

(Verify.) From (13.1.17) and (13.1.19),

$$B_1(y) = B_1(y_1) \int_a^b \frac{F(t)y_2(t)}{P_0(t)W(t)} dt = 0$$

because  $B_1(y_1) = 0$ , and

$$B_2(y) = B_2(y_2) \int_a^b \frac{F(t)y_1(t)}{P_0(t)W(t)} dt = 0$$

because  $B_2(y_2) = 0$ . Hence,  $y$  satisfies (13.1.16). This completes the proof.

We can rewrite (13.1.17) as

$$y = \int_a^b G(x, t) F(t) dt, \quad (13.1.20)$$

where

$$G(x, t) = \begin{cases} \frac{y_1(t)y_2(x)}{P_0(t)W(t)}, & a \leq t \leq x, \\ \frac{y_1(x)y_2(t)}{P_0(t)W(t)}, & x \leq t \leq b. \end{cases}$$



This is the *Green's function* for the boundary value problem (13.1.16). The Green's function is related to the boundary value problem (13.1.16) in much the same way that the inverse of a square matrix  $\mathbf{A}$  is related to the linear algebraic system  $\mathbf{y} = \mathbf{A}\mathbf{x}$ ; just as we substitute the given vector  $\mathbf{y}$  into the formula  $\mathbf{x} = \mathbf{A}^{-1}\mathbf{y}$  to solve  $\mathbf{y} = \mathbf{A}\mathbf{x}$ , we substitute the given function  $F$  into the formula (13.1.20) to obtain the solution of (13.1.16). The analogy goes further: just as  $\mathbf{A}^{-1}$  exists if and only if  $\mathbf{A}\mathbf{x} = \mathbf{0}$  has only the trivial solution, the boundary value problem (13.1.16) has a Green's function if and only if the homogeneous boundary value problem (13.1.15) has only the trivial solution.

We leave it to you (Exercise 32) to show that the assumptions of Theorem 13.1.3 imply that the unique solution of the boundary value problem

$$Ly = F, \quad B_1(y) = k_1, \quad B_2(y) = k_2$$

is

$$y(x) = \int_a^b G(x, t)F(t) dt + \frac{k_2}{B_2(y_1)}y_1 + \frac{k_1}{B_1(y_2)}y_2.$$

**Example 13.1.6** Solve the boundary value problem

$$y'' + y = F(x), \quad y(0) + y'(0) = 0, \quad y(\pi) - y'(\pi) = 0, \quad (13.1.21)$$

and find the Green's function for this problem.

**Solution** Here

$$B_1(y) = y(0) + y'(0) \quad \text{and} \quad B_2(y) = y(\pi) - y'(\pi).$$

Let  $\{z_1, z_2\} = \{\cos x, \sin x\}$ , which is a fundamental set of solutions of  $y'' + y = 0$ . Then

$$\begin{aligned} B_1(z_1) &= (\cos x - \sin x)|_{x=0} = 1 \\ B_2(z_1) &= (\cos x + \sin x)|_{x=\pi} = -1 \end{aligned}$$

and

$$\begin{aligned} B_1(z_2) &= (\sin x + \cos x)|_{x=0} = 1 \\ B_2(z_2) &= (\sin x - \cos x)|_{x=\pi} = 1. \end{aligned}$$

Therefore

$$B_1(z_1)B_2(z_2) - B_1(z_2)B_2(z_1) = 2,$$

so Theorem 13.1.2 implies that (13.1.21) has a unique solution. Let

$$y_1 = B_1(z_2)z_1 - B_1(z_1)z_2 = \cos x - \sin x$$

and

$$y_2 = B_2(z_2)z_1 - B_2(z_1)z_2 = \cos x + \sin x.$$

Then  $B_1(y_1) = 0$ ,  $B_2(y_2) = 0$ , and the Wronskian of  $\{y_1, y_2\}$  is

$$W(x) = \begin{vmatrix} \cos x - \sin x & \cos x + \sin x \\ -\sin x - \cos x & -\sin x + \cos x \end{vmatrix} = 2.$$

Since  $P_0 = 1$ , (13.1.17) yields the solution

$$\begin{aligned} y(x) &= \frac{\cos x - \sin x}{2} \int_x^\pi F(t)(\cos t + \sin t) dt \\ &\quad + \frac{\cos x + \sin x}{2} \int_0^x F(t)(\cos t - \sin t) dt. \end{aligned}$$

The Green's function is

$$G(x, t) = \begin{cases} \frac{(\cos t - \sin t)(\cos x + \sin x)}{2}, & 0 \leq t \leq x, \\ \frac{(\cos x - \sin x)(\cos t + \sin t)}{2}, & x \leq t \leq \pi. \end{cases}$$

We'll now consider the situation not covered by Theorem 13.1.3.

**Theorem 13.1.4** *Suppose the homogeneous boundary value problem*

$$Ly = 0, \quad B_1(y) = 0, \quad B_2(y) = 0 \quad (13.1.22)$$

*has a nontrivial solution  $y_1$ , and let  $y_2$  be any solution of  $Ly = 0$  that isn't a constant multiple of  $y_1$ . Let  $W = y_1 y_2' - y_1' y_2$ . If*

$$\int_a^b \frac{F(t)y_1(t)}{P_0(t)W(t)} dt = 0, \quad (13.1.23)$$

*then the homogeneous boundary value problem*

$$Ly = F, \quad B_1(y) = 0, \quad B_2(y) = 0 \quad (13.1.24)$$

*has infinitely many solutions, all of the form  $y = y_p + c_1 y_1$ , where*

$$y_p = y_1(x) \int_x^b \frac{F(t)y_2(t)}{P_0(t)W(t)} dt + y_2(x) \int_a^x \frac{F(t)y_1(t)}{P_0(t)W(t)} dt$$

*and  $c_1$  is a constant. If*

$$\int_a^b \frac{F(t)y_1(t)}{P_0(t)W(t)} dt \neq 0,$$

*then (13.1.24) has no solution.*

**Proof** From the proof of Theorem 13.1.3,  $y_p$  is a particular solution of  $Ly = F$ , and

$$y_p'(x) = y_1'(x) \int_x^b \frac{F(t)y_2(t)}{P_0(t)W(t)} dt + y_2'(x) \int_a^x \frac{F(t)y_1(t)}{P_0(t)W(t)} dt.$$

Therefore the general solution of (13.1.22) is of the form

$$y = y_p + c_1 y_1 + c_2 y_2,$$

where  $c_1$  and  $c_2$  are constants. Then

$$\begin{aligned} B_1(y) &= B_1(y_p + c_1 y_1 + c_2 y_2) = B_1(y_p) + c_1 B_1(y_1) + c_2 B_1(y_2) \\ &= B_1(y_1) \int_a^b \frac{F(t)y_2(t)}{P_0(t)W(t)} dt + c_1 B_1(y_1) + c_2 B_1(y_2) \\ &= c_2 B_1(y_2) \end{aligned}$$

Since  $B_1(y_1) = 0$ , Theorem 13.1.1 implies that  $B_1(y_2) \neq 0$ ; hence,  $B_1(y) = 0$  if and only if  $c_2 = 0$ . Therefore  $y = y_p + c_1 y_1$  and

$$\begin{aligned} B_2(y) &= B_2(y_p + c_1 y_1) = B_2(y_2) \int_a^b \frac{F(t)y_1(t)}{P_0(t)W(t)} dt + c_1 B_2(y_1) \\ &= B_2(y_2) \int_a^b \frac{F(t)y_1(t)}{P_0(t)W(t)} dt, \end{aligned}$$

since  $B_2(y_1) = 0$ . From Theorem 13.1.1,  $B_2(y_2) \neq 0$  (since  $B_2(y_1) = 0$ ). Therefore  $Ly = 0$  if and only if (13.1.23) holds. This completes the proof.

**Example 13.1.7** Applying Theorem 13.1.4 to the boundary value problem

$$y'' + y = F(x), \quad y(0) = 0, \quad y(\pi) = 0 \quad (13.1.25)$$

explains the Examples 13.1.2 and 13.1.3. The complementary equation  $y'' + y = 0$  has the linear independent solutions  $y_1 = \sin x$  and  $y_2 = \cos x$ , and  $y_1$  satisfies both boundary conditions. Since  $P_0 = 1$  and

$$W = \begin{vmatrix} \sin x & \cos x \\ \cos x & -\sin x \end{vmatrix} = -1,$$

(13.1.23) reduces to

$$\int_0^\pi F(x) \sin x \, dx = 0.$$

From Example 13.1.2,  $F(x) = 1$  and

$$\int_0^\pi F(x) \sin x \, dx = \int_0^\pi \sin x \, dx = 2,$$

so Theorem 13.1.3 implies that (13.1.25) has no solution. In Example 13.1.3,

$$F(x) = \sin 2x = 2 \sin x \cos x$$

and

$$\int_0^\pi F(x) \sin x \, dx = 2 \int_0^\pi \sin^2 x \cos x \, dx = \frac{2}{3} \sin^3 x \Big|_0^\pi = 0,$$

so Theorem 13.1.3 implies that (13.1.25) has infinitely many solutions, differing by constant multiples of  $y_1(x) = \sin x$ .

## 13.1 Exercises

---

1. Verify that  $B_1$  and  $B_2$  are linear operators; that is, if  $c_1$  and  $c_2$  are constants then

$$B_i(c_1 y_1 + c_2 y_2) = c_1 B_i(y_1) + c_2 B_i(y_2), \quad i = 1, 2.$$

In Exercises 2–7 solve the boundary value problem.

2.  $y'' - y = x, \quad y(0) = -2, \quad y(1) = 1$
3.  $y'' = 2 - 3x, \quad y(0) = 0, \quad y(1) - y'(1) = 0$
4.  $y'' - y = x, \quad y(0) + y'(0) = 3, \quad y(1) - y'(1) = 2$
5.  $y'' + 4y = 1, \quad y(0) = 3, \quad y(\pi/2) + y'(\pi/2) = -7$
6.  $y'' - 2y' + y = 2e^x, \quad y(0) - 2y'(0) = 3, \quad y(1) + y'(1) = 6e$
7.  $y'' - 7y' + 12y = 4e^{2x}, \quad y(0) + y'(0) = 8, \quad y(1) = -7e^2$  (see Example 13.1.5)
8. State a condition on  $F$  such that the boundary value problem

$$y'' = F(x), \quad y(0) = 0, \quad y(1) - y'(1) = 0$$

has a solution, and find all solutions.

9. (a) State a condition on  $a$  and  $b$  such that the boundary value problem

$$y'' + y = F(x), \quad y(a) = 0, \quad y(b) = 0 \quad (\text{A})$$

has a unique solution for every continuous  $F$ , and find the solution by the method used to prove Theorem 13.1.3

- (b) In the case where  $a$  and  $b$  don't satisfy the condition you gave for (a), state necessary and sufficient on  $F$  such that (A) has a solution, and find all solutions by the method used to prove Theorem 13.1.4.

10. Follow the instructions in Exercise 9 for the boundary value problem

$$y'' + y = F(x), \quad y(a) = 0, \quad y'(b) = 0.$$

11. Follow the instructions in Exercise 9 for the boundary value problem

$$y'' + y = F(x), \quad y'(a) = 0, \quad y'(b) = 0.$$

In Exercises 12–15 find a formula for the solution of the boundary problem by the method used to prove Theorem 13.1.3. Assume that  $a < b$ .

12.  $y'' - y = F(x), \quad y(a) = 0, \quad y(b) = 0$   
 13.  $y'' - y = F(x), \quad y(a) = 0, \quad y'(b) = 0$   
 14.  $y'' - y = F(x), \quad y'(a) = 0, \quad y'(b) = 0$   
 15.  $y'' - y = F(x), \quad y(a) - y'(a) = 0, \quad y(b) + y'(b) = 0$

In Exercises 16–19 find all values of  $\omega$  such that boundary problem has a unique solution, and find the solution by the method used to prove Theorem 13.1.3. For other values of  $\omega$ , find conditions on  $F$  such that the problem has a solution, and find all solutions by the method used to prove Theorem 13.1.4.

16.  $y'' + \omega^2 y = F(x), \quad y(0) = 0, \quad y(\pi) = 0$   
 17.  $y'' + \omega^2 y = F(x), \quad y(0) = 0, \quad y'(\pi) = 0$   
 18.  $y'' + \omega^2 y = F(x), \quad y'(0) = 0, \quad y(\pi) = 0$   
 19.  $y'' + \omega^2 y = F(x), \quad y'(0) = 0, \quad y'(\pi) = 0$   
 20. Let  $\{z_1, z_2\}$  be a fundamental set of solutions of  $Ly = 0$ . Given that the homogeneous boundary value problem

$$Ly = 0, \quad B_1(y) = 0, \quad B_2(y) = 0$$

has a nontrivial solution, express it explicitly in terms of  $z_1$  and  $z_2$ .

21. If the boundary value problem has a solution for every continuous  $F$ , then find the Green's function for the problem and use it to write an explicit formula for the solution. Otherwise, if the boundary value problem does not have a solution for every continuous  $F$ , find a necessary and sufficient condition on  $F$  for the problem to have a solution, and find all solutions. Assume that  $a < b$ .
- (a)  $y'' = F(x), \quad y(a) = 0, \quad y(b) = 0$   
 (b)  $y'' = F(x), \quad y(a) = 0, \quad y'(b) = 0$   
 (c)  $y'' = F(x), \quad y'(a) = 0, \quad y(b) = 0$   
 (d)  $y'' = F(x), \quad y'(a) = 0, \quad y'(b) = 0$

22. Find the Green's function for the boundary value problem

$$y'' = F(x), \quad y(0) - 2y'(0) = 0, \quad y(1) + 2y'(1) = 0. \quad (\text{A})$$

Then use the Green's function to solve (A) with **(a)**  $F(x) = 1$ , **(b)**  $F(x) = x$ , and **(c)**  $F(x) = x^2$ .

23. Find the Green's function for the boundary value problem

$$x^2y'' + xy' + (x^2 - 1/4)y = F(x), \quad y(\pi/2) = 0, \quad y(\pi) = 0, \quad (\text{A})$$

given that

$$y_1(x) = \frac{\cos x}{\sqrt{x}} \quad \text{and} \quad y_2(x) = \frac{\sin x}{\sqrt{x}}$$

are solutions of the complementary equation. Then use the Green's function to solve (A) with **(a)**  $F(x) = x^{3/2}$  and **(b)**  $F(x) = x^{5/2}$ .

24. Find the Green's function for the boundary value problem

$$x^2y'' - 2xy' + 2y = F(x), \quad y(1) = 0, \quad y(2) = 0, \quad (\text{A})$$

given that  $\{x, x^2\}$  is a fundamental set of solutions of the complementary equation. Then use the Green's function to solve (A) with **(a)**  $F(x) = 2x^3$  and **(b)**  $F(x) = 6x^4$ .

25. Find the Green's function for the boundary value problem

$$x^2y'' + xy' - y = F(x), \quad y(1) - 2y'(1) = 0, \quad y'(2) = 0, \quad (\text{A})$$

given that  $\{x, 1/x\}$  is a fundamental set of solutions of the complementary equation. Then use the Green's function to solve (A) with **(a)**  $F(x) = 1$ , **(b)**  $F(x) = x^2$ , and **(c)**  $F(x) = x^3$ .

*In Exercises 26–30 find necessary and sufficient conditions on  $\alpha$ ,  $\beta$ ,  $\rho$ , and  $\delta$  for the boundary value problem to have a unique solution for every continuous  $F$ , and find the Green's function.*

26.  $y'' = F(x), \quad \alpha y(0) + \beta y'(0) = 0, \quad \rho y(1) + \delta y'(1) = 0$

27.  $y'' + y = F(x), \quad \alpha y(0) + \beta y'(0) = 0, \quad \rho y(\pi) + \delta y'(\pi) = 0$

28.  $y'' + y = F(x), \quad \alpha y(0) + \beta y'(0) = 0, \quad \rho y(\pi/2) + \delta y'(\pi/2) = 0$

29.  $y'' - 2y' + 2y = F(x), \quad \alpha y(0) + \beta y'(0) = 0, \quad \rho y(\pi) + \delta y'(\pi) = 0$

30.  $y'' - 2y' + 2y = F(x), \quad \alpha y(0) + \beta y'(0) = 0, \quad \rho y(\pi/2) + \delta y'(\pi/2) = 0$

31. Find necessary and sufficient conditions on  $\alpha$ ,  $\beta$ ,  $\rho$ , and  $\delta$  for the boundary value problem

$$y'' - y = F(x), \quad \alpha y(a) + \beta y'(a) = 0, \quad \rho y(b) + \delta y'(b) = 0 \quad (\text{A})$$

to have a unique solution for every continuous  $F$ , and find the Green's function for (A). Assume that  $a < b$ .

32. Show that the assumptions of Theorem 13.1.3 imply that the unique solution of

$$Ly = F, \quad B_1(y) = k_1, \quad B_2(y) = f_2$$

is

$$y = \int_a^b G(x, t)F(t) dt + \frac{k_2}{B_2}(y_1)y_1 + \frac{k_1}{B_1(y_2)}y_2.$$

**13.2 STURM-LIOUVILLE PROBLEMS**

In this section we consider eigenvalue problems of the form

$$P_0(x)y'' + P_1(x)y' + P_2(x)y + \lambda R(x)y = 0, \quad B_1(y) = 0, \quad B_2(y) = 0, \quad (13.2.1)$$

where

$$B_1(y) = \alpha y(a) + \beta y'(a) \quad \text{and} \quad B_2(y) = \rho y(b) + \delta y'(b).$$

As in Section 13.1,  $\alpha$ ,  $\beta$ ,  $\rho$ , and  $\delta$  are real numbers, with

$$\alpha^2 + \beta^2 > 0 \quad \text{and} \quad \rho^2 + \delta^2 > 0,$$

$P_0$ ,  $P_1$ ,  $P_2$ , and  $R$  are continuous, and  $P_0$  and  $R$  are positive on  $[a, b]$ .

We say that  $\lambda$  is an *eigenvalue* of (13.2.1) if (13.2.1) has a nontrivial solution  $y$ . In this case,  $y$  is an *eigenfunction associated with  $\lambda$* , or a  $\lambda$ -*eigenfunction*. Solving the eigenvalue problem means finding all eigenvalues and associated eigenfunctions of (13.2.1).

**Example 13.2.1** Solve the eigenvalue problem

$$y' + 3y' + 2y + \lambda y = 0, \quad y(0) = 0, \quad y(1) = 0. \quad (13.2.2)$$

**Solution** The characteristic equation of (13.2.2) is

$$r^2 + 3r + 2 + \lambda = 0,$$

with zeros

$$r_1 = \frac{-3 + \sqrt{1 - 4\lambda}}{2} \quad \text{and} \quad r_2 = \frac{-3 - \sqrt{1 - 4\lambda}}{2}.$$

If  $\lambda < 1/4$  then  $r_1$  and  $r_2$  are real and distinct, so the general solution of the differential equation in (13.2.2) is

$$y = c_1 e^{r_1 t} + c_2 e^{r_2 t}.$$

The boundary conditions require that

$$\begin{aligned} c_1 + c_2 &= 0 \\ c_1 e^{r_1} + c_2 e^{r_2} &= 0. \end{aligned}$$

Since the determinant of this system is  $e^{r_2} - e^{r_1} \neq 0$ , the system has only the trivial solution. Therefore  $\lambda$  isn't an eigenvalue of (13.2.2).

If  $\lambda = 1/4$  then  $r_1 = r_2 = -3/2$ , so the general solution of (13.2.2) is

$$y = e^{-3x/2}(c_1 + c_2 x).$$

The boundary condition  $y(0) = 0$  requires that  $c_1 = 0$ , so  $y = c_2 x e^{-3x/2}$  and the boundary condition  $y(1) = 0$  requires that  $c_2 = 0$ . Therefore  $\lambda = 1/4$  isn't an eigenvalue of (13.2.2).

If  $\lambda > 1/4$  then

$$r_1 = -\frac{3}{2} + i\omega \quad \text{and} \quad r_2 = -\frac{3}{2} - i\omega,$$

with

$$\omega = \frac{\sqrt{4\lambda - 1}}{2} \quad \text{or, equivalently,} \quad \lambda = \frac{1 + 4\omega^2}{4}. \quad (13.2.3)$$

In this case the general solution of the differential equation in (13.2.2) is

$$y = e^{-3x/2}(c_1 \cos \omega x + c_2 \sin \omega x).$$

The boundary condition  $y(0) = 0$  requires that  $c_1 = 0$ , so  $y = c_2 e^{-3x/2} \sin \omega x$ , which holds with  $c_2 \neq 0$  if and only if  $\omega = n\pi$ , where  $n$  is an integer. We may assume that  $n$  is a positive integer. (Why?). From (13.2.3), the eigenvalues are  $\lambda_n = (1 + 4n^2\pi^2)/4$ , with associated eigenfunctions

$$y_n = e^{-3x/2} \sin n\pi x, \quad n = 1, 2, 3, \dots$$

**Example 13.2.2** Solve the eigenvalue problem

$$x^2 y'' + xy' + \lambda y = 0, \quad y(1) = 0, \quad y(2) = 0. \quad (13.2.4)$$

**Solution** If  $\lambda = 0$ , the differential equation in (13.2.4) reduces to  $x(xy')' = 0$ , so  $xy' = c_1$ ,

$$y' = \frac{c_1}{x}, \quad \text{and} \quad y = c_1 \ln x + c_2.$$

The boundary condition  $y(1) = 0$  requires that  $c_2 = 0$ , so  $y = c_1 \ln x$ . The boundary condition  $y(2) = 0$  requires that  $c_1 \ln 2 = 0$ , so  $c_1 = 0$ . Therefore zero isn't an eigenvalue of (13.2.4).

If  $\lambda < 0$ , we write  $\lambda = -k^2$  with  $k > 0$ , so (13.2.4) becomes

$$x^2 y'' + xy' - k^2 y = 0,$$

an Euler equation (Section 7.4) with indicial equation

$$r^2 - k^2 = (r - k)(r + k) = 0.$$

Therefore

$$y = c_1 x^k + c_2 x^{-k}.$$

The boundary conditions require that

$$\begin{aligned} c_1 + c_2 &= 0 \\ 2^k c_1 + 2^{-k} c_2 &= 0. \end{aligned}$$

Since the determinant of this system is  $2^{-k} - 2^k \neq 0$ ,  $c_1 = c_2 = 0$ . Therefore (13.2.4) has no negative eigenvalues.

If  $\lambda > 0$  we write  $\lambda = k^2$  with  $k > 0$ . Then (13.2.4) becomes

$$x^2 y'' + xy' + k^2 y = 0,$$

an Euler equation with indicial equation

$$r^2 + k^2 = (r - ik)(r + ik) = 0,$$

so

$$y = c_1 \cos(k \ln x) + c_2 \sin(k \ln x).$$

The boundary condition  $y(1) = 0$  requires that  $c_1 = 0$ . Therefore  $y = c_2 \sin(k \ln x)$ . This holds with  $c_2 \neq 0$  if and only if  $k = n\pi/\ln 2$ , where  $n$  is a positive integer. Hence, the eigenvalues of (13.2.4) are  $\lambda_n = (n\pi/\ln 2)^2$ , with associated eigenfunctions

$$y_n = \sin\left(\frac{n\pi}{\ln 2} \ln x\right), \quad n = 1, 2, 3, \dots$$

For theoretical purposes, it's useful to rewrite the differential equation in (13.2.1) in a different form, provided by the next theorem.

**Theorem 13.2.1** *If  $P_0, P_1, P_2,$  and  $R$  are continuous and  $P_0$  and  $R$  are positive on a closed interval  $[a, b]$ , then the equation*

$$P_0(x)y'' + P_1(x)y' + P_2(x)y + \lambda R(x)y = 0 \quad (13.2.5)$$

can be rewritten as

$$(p(x)y')' + q(x)y + \lambda r(x)y = 0, \quad (13.2.6)$$

where  $p, p', q$  and  $r$  are continuous and  $p$  and  $r$  are positive on  $[a, b]$ .

**Proof** We begin by rewriting (13.2.5) as

$$y'' + u(x)y' + v(x)y + \lambda R_1(x)y = 0, \quad (13.2.7)$$

with  $u = P_1/P_0, v = P_2/P_0,$  and  $R_1 = R/P_0.$  (Note that  $R_1$  is positive on  $[a, b].$ ) Now let  $p(x) = e^{U(x)},$  where  $U$  is any antiderivative of  $u.$  Then  $p$  is positive on  $[a, b]$  and, since  $U' = u,$

$$p'(x) = p(x)u(x) \quad (13.2.8)$$

is continuous on  $[a, b].$  Multiplying (13.2.7) by  $p(x)$  yields

$$p(x)y'' + p(x)u(x)y' + p(x)v(x)y + \lambda p(x)R_1(x)y = 0. \quad (13.2.9)$$

Since  $p$  is positive on  $[a, b],$  this equation has the same solutions as (13.2.5). From (13.2.8),

$$(p(x)y')' = p(x)y'' + p'(x)y' = p(x)y'' + p(x)u(x)y',$$

so (13.2.9) can be rewritten as in (13.2.6), with  $q(x) = p(x)v(x)$  and  $r(x) = p(x)R_1(x).$  This completes the proof.

It is to be understood throughout the rest of this section that  $p, q,$  and  $r$  have the properties stated in Theorem 13.2.1. Moreover, whenever we write  $Ly$  in a general statement, we mean

$$Ly = (p(x)y')' + q(x)y.$$

The differential equation (13.2.6) is called a *Sturm–Liouville equation*, and the eigenvalue problem

$$(p(x)y')' + q(x)y + \lambda r(x)y = 0, \quad B_1(y) = 0, \quad B_2(y) = 0, \quad (13.2.10)$$

which is equivalent to (13.2.1), is called a *Sturm–Liouville problem*.

**Example 13.2.3** Rewrite the eigenvalue problem

$$y'' + 3y' + (2 + \lambda)y = 0, \quad y(0) = 0, \quad y(1) = 0 \quad (13.2.11)$$

of Example 13.2.1 as a Sturm–Liouville problem.

**Solution** Comparing (13.2.11) to (13.2.7) shows that  $u(x) = 3,$  so we take  $U(x) = 3x$  and  $p(x) = e^{3x}.$  Multiplying the differential equation in (13.2.11) by  $e^{3x}$  yields

$$e^{3x}(y'' + 3y') + 2e^{3x}y + \lambda e^{3x}y = 0.$$

Since

$$e^{3x}(y'' + 3y') = (e^{3x}y')',$$

(13.2.11) is equivalent to the Sturm–Liouville problem

$$(e^{3x}y')' + 2e^{3x}y + \lambda e^{3x}y = 0, \quad y(0) = 0, \quad y(1) = 0. \quad (13.2.12)$$



**Example 13.2.4** Rewrite the eigenvalue problem

$$x^2 y'' + xy' + \lambda y = 0, \quad y(1) = 0, \quad y(2) = 0 \quad (13.2.13)$$

of Example 13.2.2 as a Sturm-Liouville problem.

**Solution** Dividing the differential equation in (13.2.13) by  $x^2$  yields

$$y'' + \frac{1}{x}y' + \frac{\lambda}{x^2}y = 0.$$

Comparing this to (13.2.7) shows that  $u(x) = 1/x$ , so we take  $U(x) = \ln x$  and  $p(x) = e^{\ln x} = x$ . Multiplying the differential equation by  $x$  yields

$$xy'' + y' + \frac{\lambda}{x}y = 0.$$

Since

$$xy'' + y' = (xy')',$$

(13.2.13) is equivalent to the Sturm–Liouville problem

$$(xy')' + \frac{\lambda}{x}y = 0, \quad y(1) = 0, \quad y(2) = 0. \quad (13.2.14)$$

Problems 1–4 of Section 11.1 are Sturm–Liouville problems. (Problem 5 isn't, although some authors use a definition of *Sturm-Liouville problem* that does include it.) We were able to find the eigenvalues of Problems 1–4 explicitly because in each problem the coefficients in the boundary conditions satisfy  $\alpha\beta = 0$  and  $\rho\delta = 0$ ; that is, each boundary condition involves either  $y$  or  $y'$ , but not both. If this isn't true then the eigenvalues can't in general be expressed exactly by simple formulas; rather, approximate values must be obtained by numerical solution of equations derived by requiring the determinants of certain  $2 \times 2$  systems of homogeneous equations to be zero. To apply the numerical methods effectively, graphical methods must be used to determine approximate locations of the zeros of these determinants. Then the zeros can be computed accurately by numerical methods. ■

**Example 13.2.5** Solve the Sturm–Liouville problem

$$y'' + \lambda y = 0, \quad y(0) + y'(0) = 0, \quad y(1) + 3y'(1) = 0. \quad (13.2.15)$$

**Solution** If  $\lambda = 0$ , the differential equation in (13.2.15) reduces to  $y'' = 0$ , with general solution  $y = c_1 + c_2x$ . The boundary conditions require that

$$\begin{aligned} c_1 + c_2 &= 0 \\ c_1 + 4c_2 &= 0, \end{aligned}$$

so  $c_1 = c_2 = 0$ . Therefore zero isn't an eigenvalue of (13.2.15).

If  $\lambda < 0$ , we write  $\lambda = -k^2$  where  $k > 0$ , and the differential equation in (13.2.15) becomes  $y'' - k^2y = 0$ , with general solution

$$y = c_1 \cosh kx + c_2 \sinh kx, \quad (13.2.16)$$

so

$$y' = k(c_1 \sinh kx + c_2 \cosh kx).$$

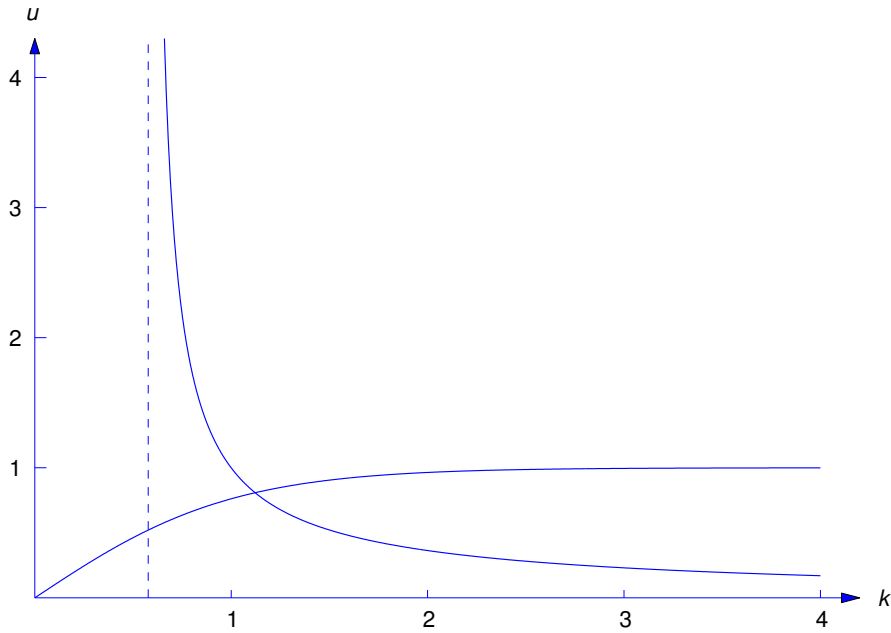

Figure 13.2.1  $u = \tanh k$  and  $u = -2k/(1 - 3k^2)$

The boundary conditions require that

$$\begin{aligned} c_1 + kc_2 &= 0 \\ (\cosh k + 3k \sinh k)c_1 + (\sinh k + 3k \cosh k)c_2 &= 0. \end{aligned} \tag{13.2.17}$$

The determinant of this system is

$$\begin{aligned} D_N(k) &= \begin{vmatrix} 1 & k \\ \cosh k + 3k \sinh k & \sinh k + 3k \cosh k \end{vmatrix} \\ &= (1 - 3k^2) \sinh k + 2k \cosh k. \end{aligned}$$

Therefore the system (13.2.17) has a nontrivial solution if and only if  $D_N(k) = 0$  or, equivalently,

$$\tanh k = -\frac{2k}{1 - 3k^2}. \tag{13.2.18}$$

The graph of the right side (Figure 13.2.1) has a vertical asymptote at  $k = 1/\sqrt{3}$ . Since the two sides have different signs if  $k < 1/\sqrt{3}$ , this equation has no solution in  $(0, 1/\sqrt{3})$ . Figure 13.2.1 shows the graphs of the two sides of (13.2.18) on an interval to the right of the vertical asymptote, which is indicated by the dashed line. You can see that the two curves intersect near  $k_0 = 1.2$ . Given this estimate, you can use Newton's to compute  $k_0$  more accurately. We computed  $k_0 \approx 1.1219395$ . Therefore  $-k_0^2 \approx -1.2587483$  is an eigenvalue of (13.2.15). From (13.2.16) and the first equation in (13.2.17),

$$y_0 = k_0 \cosh k_0 x - \sinh k_0 x.$$

If  $\lambda > 0$  we write  $\lambda = k^2$  where  $k > 0$ , and differential equation in (13.2.15) becomes  $y'' + k^2 y = 0$ , with general solution

$$y = c_1 \cos kx + c_2 \sin kx, \tag{13.2.19}$$

so

$$y' = k(-c_1 \sin kx + c_2 \cos kx).$$

The boundary conditions require that

$$\begin{aligned} c_1 + kc_2 &= 0 \\ (\cos k - 3k \sin k)c_1 + (\sin k + 3k \cos k)c_2 &= 0. \end{aligned} \quad (13.2.20)$$

The determinant of this system is

$$\begin{aligned} D_P(k) &= \begin{vmatrix} 1 & k \\ \cos k - 3k \sin k & \sin k + 3k \cos k \end{vmatrix} \\ &= (1 + 3k^2) \sin k + 2k \cos k. \end{aligned}$$

The system (13.2.20) has a nontrivial solution if and only if  $D_P(k) = 0$  or, equivalently,

$$\tan k = -\frac{2k}{1 + 3k^2}.$$

Figure 13.2.2 shows the graphs of the two sides of this equation. You can see from the figure that the graphs intersect at infinitely many points  $k_n \approx n\pi$  ( $n = 1, 2, 3, \dots$ ), where the error in this approximation approaches zero as  $n \rightarrow \infty$ . Given this estimate, you can use Newton's method to compute  $k_n$  more accurately. We computed

$$\begin{aligned} k_1 &\approx 2.9256856, \\ k_2 &\approx 6.1765914, \\ k_3 &\approx 9.3538959, \\ k_4 &\approx 12.5132570. \end{aligned}$$

The estimates of the corresponding eigenvalues  $\lambda_n = k_n^2$  are

$$\begin{aligned} \lambda_1 &\approx 8.5596361, \\ \lambda_2 &\approx 38.1502809, \\ \lambda_3 &\approx 87.4953676, \\ \lambda_4 &\approx 156.5815998. \end{aligned}$$

From (13.2.19) and the first equation in (13.2.20),

$$y_n = k_n \cos k_n x - \sin k_n x$$

is an eigenfunction associated with  $\lambda_n$  ■

Since the differential equations in (13.2.12) and (13.2.14) are more complicated than those in (13.2.11) and (13.2.13) respectively, what is the point of Theorem 13.2.1? The point is this: to solve a *specific* problem, it may be better to deal with it directly, as we did in Examples 13.2.1 and 13.2.2; however, we'll see that transforming the *general* eigenvalue problem (13.2.1) to the Sturm–Liouville problem (13.2.10) leads to results applicable to *all* eigenvalue problems of the form (13.2.1).

**Theorem 13.2.2** *If*

$$Ly = (p(x)y')' + q(x)y$$

*and  $u$  and  $v$  are twice continuously functions on  $[a, b]$  that satisfy the boundary conditions  $B_1(y) = 0$  and  $B_2(y) = 0$ , then*

$$\int_a^b [u(x)Lv(x) - v(x)Lu(x)] dx = 0. \quad (13.2.21)$$

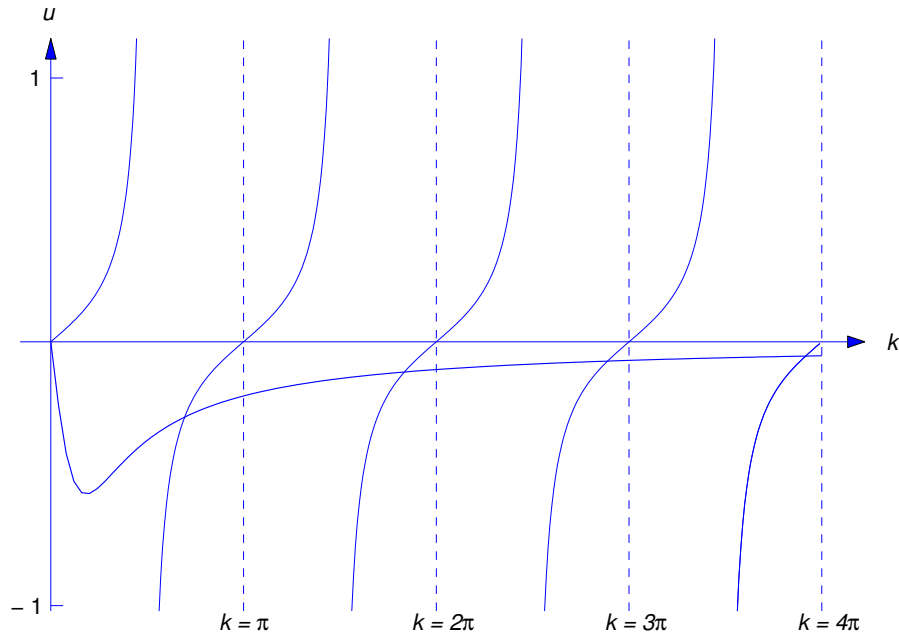

Figure 13.2.2  $u = \tan k$  and  $u = -2k/(1+k)$

**Proof** Integration by parts yields

$$\begin{aligned} \int_a^b [u(x)Lv(x) - v(x)Lu(x)] dx &= \int_a^b [u(x)(p(x)v'(x))' - v(x)(p(x)u'(x))'] dx \\ &= p(x)[u(x)v'(x) - u'(x)v(x)] \Big|_a^b \\ &\quad - \int_a^b p(x)[u'(x)v'(x) - u'(x)v'(x)] dx. \end{aligned}$$

Since the last integral equals zero,

$$\int_a^b [u(x)Lv(x) - v(x)Lu(x)] dx = p(x)[u(x)v'(x) - u'(x)v(x)] \Big|_a^b. \tag{13.2.22}$$

By assumption,  $B_1(u) = B_1(v) = 0$  and  $B_2(u) = B_2(v) = 0$ . Therefore

$$\begin{aligned} \alpha u(a) + \beta u'(a) = 0 &\quad \text{and} \quad \rho u(b) + \delta u'(b) = 0 \\ \alpha v(a) + \beta v'(a) = 0 &\quad \text{and} \quad \rho v(b) + \delta v'(b) = 0. \end{aligned}$$

Since  $\alpha^2 + \beta^2 > 0$  and  $\rho^2 + \delta^2 > 0$ , the determinants of these two systems must both be zero; that is,

$$u(a)v'(a) - u'(a)v(a) = u(b)v'(b) - u'(b)v(b) = 0.$$

This and (13.2.22) imply (13.2.21), which completes the proof.

The next theorem shows that a Sturm–Liouville problem has no complex eigenvalues.

**Theorem 13.2.3** *If  $\lambda = p + qi$  with  $q \neq 0$  then the boundary value problem*

$$Ly + \lambda r(x)y = 0, \quad B_1(y) = 0, \quad B_2(y) = 0$$

*has only the trivial solution.*

**Proof** For this theorem to make sense, we must consider complex-valued solutions of

$$Ly + (p + iq)r(x)y = 0. \quad (13.2.23)$$

If  $y = u + iv$  where  $u$  and  $v$  are real-valued and twice differentiable, we define  $y' = u' + iv'$  and  $y'' = u'' + iv''$ . We say that  $y$  is a solution of (13.2.23) if the real and imaginary parts of the left side of (13.2.23) are both zero. Since  $Ly = (p(x)y')' + q(x)y$  and  $p$ ,  $q$ , and  $r$  are real-valued,

$$\begin{aligned} Ly + \lambda r(x)y &= L(u + iv) + (p + iq)r(x)(u + iv) \\ &= Lu + r(x)(pu - qv) + i[Lv + r(x)(pu + qv)], \end{aligned}$$

so  $Ly + \lambda r(x)y = 0$  if and only if

$$\begin{aligned} Lu + r(x)(pu - qv) &= 0 \\ Lv + r(x)(qu + pv) &= 0. \end{aligned}$$

Multiplying the first equation by  $v$  and the second by  $u$  yields

$$\begin{aligned} vLu + r(x)(puv - qv^2) &= 0 \\ uLv + r(x)(qu^2 + puv) &= 0. \end{aligned}$$

Subtracting the first equation from the second yields

$$uLv - vLu + qr(x)(u^2 + v^2) = 0,$$

so

$$\int_a^b [u(x)Lv(x) - v(x)Lu(x)] dx + \int_a^b r(x)[u^2(x) + v^2(x)] dx = 0. \quad (13.2.24)$$

Since

$$B_1(y) = B_1(u + iv) = B_1(u) + iB_1(v)$$

and

$$B_2(y) = B_2(u + iv) = B_2(u) + iB_2(v),$$

$B_1(y) = 0$  and  $B_2(y) = 0$  implies that

$$B_1(u) = B_2(u) = B_1(v) = B_2(v) = 0.$$

Therefore Theorem 13.2.2 implies that first integral in (13.2.24) equals zero, so (13.2.24) reduces to

$$q \int_a^b r(x)[u^2(x) + v^2(x)] dx = 0.$$

Since  $r$  is positive on  $[a, b]$  and  $q \neq 0$  by assumption, this implies that  $u \equiv 0$  and  $v \equiv 0$  on  $[a, b]$ . Therefore  $y \equiv 0$  on  $[a, b]$ , which completes the proof.

**Theorem 13.2.4** *If  $\lambda_1$  and  $\lambda_2$  are distinct eigenvalues of the Sturm–Liouville problem*

$$Ly + \lambda r(x)y = 0, \quad B_1(y) = 0, \quad B_2(y) = 0 \tag{13.2.25}$$

*with associated eigenfunctions  $u$  and  $v$  respectively, then*

$$\int_a^b r(x)u(x)v(x) dx = 0. \tag{13.2.26}$$

**Proof** Since  $u$  and  $v$  satisfy the boundary conditions in (13.2.25), Theorem 13.2.2 implies that

$$\int_a^b [u(x)Lv(x) - v(x)Lu(x)] dx = 0.$$

Since  $Lu = -\lambda_1 ru$  and  $Lv = -\lambda_2 rv$ , this implies that

$$(\lambda_1 - \lambda_2) \int_a^b r(x)u(x)v(x) dx = 0.$$

Since  $\lambda_1 \neq \lambda_2$ , this implies (13.2.26), which completes the proof.

If  $u$  and  $v$  are any integrable functions on  $[a, b]$  and

$$\int_a^b r(x)u(x)v(x) dx = 0,$$

we say that  $u$  and  $v$  *orthogonal on  $[a, b]$  with respect to  $r = r(x)$ .*

Theorem 13.1.1 implies the next theorem.

**Theorem 13.2.5** *If  $u \not\equiv 0$  and  $v$  both satisfy*

$$Ly + \lambda r(x)y = 0, \quad B_1(y) = 0, \quad B_2(y) = 0,$$

*then  $v = cu$  for some constant  $c$ .*

We’ve now proved parts of the next theorem. A complete proof is beyond the scope of this book.

**Theorem 13.2.6** *The set of all eigenvalues of the Sturm–Liouville problem*

$$Ly + \lambda r(x)y = 0, \quad B_1(y) = 0, \quad B_2(y) = 0$$

*can be ordered as*

$$\lambda_1 < \lambda_2 < \cdots < \lambda_n < \cdots,$$

*and*

$$\lim_{n \rightarrow \infty} \lambda_n = \infty.$$

*For each  $n$ , if  $y_n$  is an arbitrary  $\lambda_n$ -eigenfunction, then every  $\lambda_n$ -eigenfunction is a constant multiple of  $y_n$ . If  $m \neq n$ ,  $y_m$  and  $y_n$  are orthogonal  $[a, b]$  with respect to  $r = r(x)$ ; that is,*

$$\int_a^b r(x)y_m(x)y_n(x) dx = 0. \tag{13.2.27}$$

You may want to verify (13.2.27) for the eigenfunctions obtained in Examples 13.2.1 and 13.2.2. In conclusion, we mention the next theorem. The proof is beyond the scope of this book.

**Theorem 13.2.7** Let  $\lambda_1 < \lambda_2 < \dots < \lambda_n < \dots$  be the eigenvalues of the Sturm–Liouville problem

$$Ly + \lambda r(x)y = 0, \quad B_1(y) = 0, \quad B_2(y) = 0,$$

with associated eigenvectors  $y_1, y_2, \dots, y_n, \dots$ . Suppose  $f$  is piecewise smooth (Definition 11.2.3) on  $[a, b]$ . For each  $n$ , let

$$c_n = \frac{\int_a^b r(x)f(x)y_n(x) dx}{\int_a^b r(x)y_n^2(x) dx}.$$

Then

$$\frac{f(x-) + f(x+)}{2} = \sum_{n=1}^{\infty} c_n y_n(x)$$

for all  $x$  in the open interval  $(a, b)$ .

### 13.2 Exercises

In Exercises 1–7 rewrite the equation in Sturm–Liouville form (with  $\lambda = 0$ ). Assume that  $b, c, \alpha$ , and  $\nu$  are constants.

1.  $y'' + by' + cy = 0$
2.  $x^2y'' + xy' + (x^2 - \nu^2)y = 0$  (Bessel's equation)
3.  $(1 - x^2)y'' - xy' + \alpha^2y = 0$  (Chebyshev's equation)
4.  $x^2y'' + bxy' + cy = 0$  (Euler's equation)
5.  $y'' - 2xy' + 2\alpha y = 0$  (Hermite's equation)
6.  $xy'' + (1 - x)y' + \alpha y = 0$  (Laguerre's equation)
7.  $(1 - x^2)y'' - 2xy' + \alpha(\alpha + 1)y = 0$  (Legendre's equation)
8. In Example 13.2.4 we found that the eigenvalue problem

$$x^2y'' + xy' + \lambda y = 0, \quad y(1) = 0, \quad y(2) = 0 \tag{A}$$

is equivalent to the Sturm-Liouville problem

$$(xy')' + \frac{\lambda}{x}y = 0, \quad y(1) = 0, \quad y(2) = 0. \tag{B}$$

Multiply the differential equation in (B) by  $y$  and integrate to show that

$$\lambda \int_1^2 \frac{y^2(x)}{x} dx = \int_1^2 x(y'(x))^2 dx.$$

Conclude from this that the eigenvalues of (A) are all positive.

9. Solve the eigenvalue problem

$$y'' + 2y' + y + \lambda y = 0, \quad y(0) = 0, \quad y(1) = 0.$$

10. Solve the eigenvalue problem

$$y'' + 2y' + y + \lambda y = 0, \quad y'(0) = 0, \quad y'(1) = 0.$$

In Exercises 11–20 : (a) Determine whether  $\lambda = 0$  is an eigenvalue. If it is, find an associated eigenfunction.

(b) Compute the negative eigenvalues with errors not greater than  $5 \times 10^{-8}$ . State the form of the associated eigenfunctions.

(c) Compute the first four positive eigenvalues with errors not greater than  $5 \times 10^{-8}$ . State the form of the associated eigenfunctions.

11.   $y'' + \lambda y = 0, \quad y(0) + 2y'(0) = 0, \quad y(2) = 0$

12.   $y'' + \lambda y = 0, \quad y'(0) = 0, \quad y(1) - 2y'(1) = 0$

13.   $y'' + \lambda y = 0, \quad y(0) - y'(0) = 0, \quad y'(\pi) = 0$

14.   $y'' + \lambda y = 0, \quad y(0) + 2y'(0) = 0, \quad y(\pi) = 0$

15.   $y'' + \lambda y = 0, \quad y'(0) = 0, \quad y(2) - y'(2) = 0$

16.   $y'' + \lambda y = 0, \quad y(0) + y'(0) = 0, \quad y(2) + 2y'(2) = 0$

17.   $y'' + \lambda y = 0, \quad y(0) + 2y'(0) = 0, \quad y(3) - 2y'(3) = 0$

18.   $y'' + \lambda y = 0, \quad 3y(0) + y'(0) = 0, \quad 3y(2) - 2y'(2) = 0$

19.   $y'' + \lambda y = 0, \quad y(0) + 2y'(0) = 0, \quad y(3) - y'(3) = 0$

20.   $y'' + \lambda y = 0, \quad 5y(0) + 2y'(0) = 0, \quad 5y(1) - 2y'(1) = 0$

21. Find the first five eigenvalues of the boundary value problem

$$y'' + 2y' + y + \lambda y = 0, \quad y(0) = 0, \quad y'(1) = 0$$

with errors not greater than  $5 \times 10^{-8}$ . State the form of the associated eigenfunctions.

In Exercises 22–24 take it as given that  $\{xe^{kx}, xe^{-kx}\}$  and  $\{x \cos kx, x \sin kx\}$  are fundamental sets of solutions of

$$x^2 y'' - 2xy' + 2y - k^2 x^2 y = 0$$

and

$$x^2 y'' - 2xy' + 2y + k^2 x^2 y = 0,$$

respectively.

22. Solve the eigenvalue problem for

$$x^2 y'' - 2xy' + 2y + \lambda x^2 y = 0, \quad y(1) = 0, \quad y(2) = 0.$$

23.  Find the first five eigenvalues of

$$x^2 y'' - 2xy' + 2y + \lambda x^2 y = 0, \quad y'(1) = 0, \quad y(2) = 0$$

with errors no greater than  $5 \times 10^{-8}$ . State the form of the associated eigenfunctions.



24. C Find the first five eigenvalues of

$$x^2 y'' - 2xy' + 2y + \lambda x^2 y = 0, \quad y(1) = 0, \quad y'(2) = 0$$

with errors no greater than  $5 \times 10^{-8}$ . State the form of the associated eigenfunctions.

25. Consider the Sturm-Liouville problem

$$y'' + \lambda y = 0, \quad y(0) = 0, \quad y(L) + \delta y'(L) = 0. \quad (\text{A})$$

(a) Show that (A) can't have more than one negative eigenvalue, and find the values of  $\delta$  for which it has one.

(b) Find all values of  $\delta$  such that  $\lambda = 0$  is an eigenvalue of (A).

(c) Show that  $\lambda = k^2$  with  $k > 0$  is an eigenvalue of (A) if and only if

$$\tan kL = -\delta k. \quad (\text{B})$$

(d) For  $n = 1, 2, \dots$ , let  $y_n$  be an eigenfunction associated with  $\lambda_n = k_n^2$ . From Theorem 13.2.4,  $y_m$  and  $y_n$  are orthogonal over  $[0, L]$  if  $m \neq n$ . Verify this directly. HINT: *Integrate by parts twice and use (B)*.

26. Solve the Sturm-Liouville problem

$$y'' + \lambda y = 0, \quad y(0) + \alpha y'(0) = 0, \quad y(\pi) + \alpha y'(\pi) = 0,$$

where  $\alpha \neq 0$ .

27. L Consider the Sturm-Liouville problem

$$y'' + \lambda y = 0, \quad y(0) + \alpha y'(0) = 0, \quad y(1) + (\alpha - 1)y'(1) = 0, \quad (\text{A})$$

where  $0 < \alpha < 1$ .

(a) Show that  $\lambda = 0$  is an eigenvalue of (A), and find an associated eigenfunction.

(b) Show that (A) has a negative eigenvalue, and find the form of an associated eigenfunction.

(c) Give a graphical argument to show that (A) has infinitely many positive eigenvalues  $\lambda_1 < \lambda_2 < \dots < \lambda_n < \dots$ , and state the form of the associated eigenfunctions.

*Exercises 28–30 deal with the Sturm–Liouville problem*

$$y'' + \lambda y = 0, \quad \alpha y(0) + \beta y'(0), \quad \rho y(L) + \delta y'(L) = 0, \quad (\text{SL})$$

where  $\alpha^2 + \beta^2 > 0$  and  $\rho^2 + \delta^2 > 0$ .

28. Show that  $\lambda = 0$  is an eigenvalue of (SL) if and only if

$$\alpha(\rho L + \delta) - \beta\rho = 0.$$

29. L The point of this exercise is that (SL) can't have more than two negative eigenvalues.

(a) Show that  $\lambda$  is a negative eigenvalue of (SL) if and only if  $\lambda = -k^2$ , where  $k$  is a positive solution of

$$(\alpha\rho - \beta\delta k^2) \sinh kL + k(\alpha\delta - \beta\rho) \cosh kL.$$

(b) Suppose  $\alpha\delta - \beta\rho = 0$ . Show that (SL) has a negative eigenvalue if and only if  $\alpha\rho$  and  $\beta\delta$  are both nonzero. Find the negative eigenvalue and an associated eigenfunction. HINT: Show that in this case  $\rho = p\alpha$  and  $s = q\beta$ , where  $q \neq 0$ .

(c) Suppose  $\beta\rho - \alpha\delta \neq 0$ . We know from Section 11.1 that (SL) has no negative eigenvalues if  $\alpha\rho = 0$  and  $\beta\delta = 0$ . Assume that either  $\alpha\rho \neq 0$  or  $\beta\delta \neq 0$ . Then we can rewrite (A) as

$$\tanh kL = \frac{k(\beta\rho - \alpha\delta)}{\alpha\rho - \beta\delta k^2}.$$

By graphing both sides of this equation on the same axes (there are several possibilities for the right side), show that it has at most two positive solutions, so (SL) has at most two negative eigenvalues.

**30.** **L** The point of this exercise is that (SL) has infinitely many positive eigenvalues  $\lambda_1 < \lambda_2 < \dots < \lambda_n < \dots$ , and that  $\lim_{n \rightarrow \infty} \lambda_n = \infty$ .

(a) Show that  $\lambda$  is a positive eigenvalue of (SL) if and only if  $\lambda = k^2$ , where  $k$  is a positive solution of

$$(\alpha\rho + \beta\delta k^2) \sin kL + k(\alpha\delta - \beta\rho) \cos kL = 0. \quad (\text{A})$$

(b) Suppose  $\alpha\delta - \beta\rho = 0$ . Show that the positive eigenvalues of (SL) are  $\lambda_n = (n\pi/L)^2$ ,  $n = 1, 2, 3, \dots$ . HINT: Recall the hint in Exercise 29(b).

Now suppose  $\alpha\delta - \beta\rho \neq 0$ . From Section 11.1, if  $\alpha\rho = 0$  and  $\beta\delta = 0$ , then (SL) has the eigenvalues

$$\lambda_n = [(2n-1)\pi/2L]^2, \quad n = 1, 2, 3, \dots$$

(why?), so let's suppose in addition that at least one of the products  $\alpha\rho$  and  $\beta\delta$  is nonzero. Then we can rewrite (A) as

$$\tan kL = \frac{k(\beta\rho - \alpha\delta)}{\alpha\rho - \beta\delta k^2}. \quad (\text{B})$$

By graphing both sides of this equation on the same axes (there are several possibilities for the right side), convince yourself of the following:

(c) If  $\beta\delta = 0$ , there's a positive integer  $N$  such that (B) has one solution  $k_n$  in each of the intervals

$$((2n-1)\pi/L, (2n+1)\pi/L), \quad n = N, N+1, N+2, \dots, \quad (\text{C})$$

and either

$$\lim_{n \rightarrow \infty} \left( k_n - \frac{(2n-1)\pi}{2L} \right) = 0 \quad \text{or} \quad \lim_{n \rightarrow \infty} \left( k_n - \frac{(2n+1)\pi}{2L} \right) = 0.$$

(d) If  $\beta\delta \neq 0$ , there's a positive integer  $N$  such that (B) has one solution  $k_n$  in each of the intervals (C) and

$$\lim_{n \rightarrow \infty} \left( k_n - \frac{n\pi}{N} \right) = 0.$$

**31.** The following Sturm–Liouville problems are generalizations of Problems 1–4 of Section 11.1.

Problem 1:  $(p(x)y')' + \lambda r(x)y = 0, \quad y(a) = 0, \quad y(b) = 0$

Problem 2:  $(p(x)y')' + \lambda r(x)y = 0, \quad y'(a) = 0, \quad y'(b) = 0$

Problem 3:  $(p(x)y')' + \lambda r(x)y = 0, \quad y(a) = 0, \quad y'(b) = 0$

Problem 4:  $(p(x)y')' + \lambda r(x)y = 0, \quad y'(a) = 0, \quad y(b) = 0$

Prove: Problems 1–4 have no negative eigenvalues. Moreover,  $\lambda = 0$  is an eigenvalue of Problem 2 with associated eigenfunction  $y_0 = 1$ , but  $\lambda = 0$  isn't an eigenvalue of Problems 1, 3, and 4. HINT: See the proof of Theorem 11.1.1.

**32.** Show that the eigenvalues of the Sturm–Liouville problem

$$(p(x)y')' + \lambda r(x)y = 0, \quad \alpha y(a) + \beta y'(a) = 0, \quad \rho y(b) + \delta y'(b)$$

are all positive if  $\alpha\beta \leq 0$ ,  $\rho\delta \geq 0$ , and  $(\alpha\beta)^2 + (\rho\delta)^2 > 0$ .

**A BRIEF TABLE OF INTEGRALS**

$$\int u^\alpha du = \frac{u^{\alpha+1}}{\alpha+1} + c, \quad \alpha \neq -1$$

$$\int \frac{du}{u} = \ln |u| + c$$

$$\int \cos u du = \sin u + c$$

$$\int \sin u du = -\cos u + c$$

$$\int \tan u du = -\ln |\cos u| + c$$

$$\int \cot u du = \ln |\sin u| + c$$

$$\int \sec^2 u du = \tan u + c$$

$$\int \csc^2 u du = -\cot u + c$$

$$\int \sec u du = \ln |\sec u + \tan u| + c$$

$$\int \cos^2 u du = \frac{u}{2} + \frac{1}{4} \sin 2u + c$$

$$\int \sin^2 u du = \frac{u}{2} - \frac{1}{4} \sin 2u + c$$

$$\int \frac{du}{1+u^2} = \tan^{-1} u + c$$

$$\int \frac{du}{\sqrt{1-u^2}} = \sin^{-1} u + c$$

$$\int \frac{1}{u^2-1} du = \frac{1}{2} \ln \left| \frac{u-1}{u+1} \right| + c$$

$$\int \cosh u du = \sinh u + c$$

$$\int \sinh u du = \cosh u + c$$

$$\int u dv = uv - \int v du$$

$$\int u \cos u du = u \sin u + \cos u + c$$

$$\int u \sin u \, du = -u \cos u + \sin u + c$$

$$\int u e^u \, du = u e^u - e^u + c$$

$$\int e^{\lambda u} \cos \omega u \, du = \frac{e^{\lambda u} (\lambda \cos \omega u + \omega \sin \omega u)}{\lambda^2 + \omega^2} + c$$

$$\int e^{\lambda u} \sin \omega u \, du = \frac{e^{\lambda u} (\lambda \sin \omega u - \omega \cos \omega u)}{\lambda^2 + \omega^2} + c$$

$$\int \ln |u| \, du = u \ln |u| - u + c$$

$$\int u \ln |u| \, du = \frac{u^2 \ln |u|}{2} - \frac{u^2}{4} + c$$

$$\int \cos \omega_1 u \cos \omega_2 u \, du = \frac{\sin(\omega_1 + \omega_2)u}{2(\omega_1 + \omega_2)} + \frac{\sin(\omega_1 - \omega_2)u}{2(\omega_1 - \omega_2)} + c \quad (\omega_1 \neq \pm\omega_2)$$

$$\int \sin \omega_1 u \sin \omega_2 u \, du = -\frac{\sin(\omega_1 + \omega_2)u}{2(\omega_1 + \omega_2)} + \frac{\sin(\omega_1 - \omega_2)u}{2(\omega_1 - \omega_2)} + c \quad (\omega_1 \neq \pm\omega_2)$$

$$\int \sin \omega_1 u \cos \omega_2 u \, du = -\frac{\cos(\omega_1 + \omega_2)u}{2(\omega_1 + \omega_2)} - \frac{\cos(\omega_1 - \omega_2)u}{2(\omega_1 - \omega_2)} + c \quad (\omega_1 \neq \pm\omega_2)$$

# Answers to Selected Exercises

## Section 1.2 Answers, pp. 14–15

1.2.1 (p. 14) (a) 3 (b) 2 (c) 1 (d) 2

1.2.3 (p. 14) (a)  $y = -\frac{x^2}{2} + c$  (b)  $y = x \cos x - \sin x + c$

(c)  $y = \frac{x^2}{2} \ln x - \frac{x^2}{4} + c$  (d)  $y = -x \cos x + 2 \sin x + c_1 + c_2x$

(e)  $y = (2x - 4)e^x + c_1 + c_2x$  (f)  $y = \frac{x^3}{3} - \sin x + e^x + c_1 + c_2x$

(g)  $y = \sin x + c_1 + c_2x + c_3x^2$  (h)  $y = -\frac{x^5}{60} + e^x + c_1 + c_2x + c_3x^2$

(i)  $y = \frac{7}{64}e^{4x} + c_1 + c_2x + c_3x^2$

1.2.4 (p. 14) (a)  $y = -(x - 1)e^x$  (b)  $y = 1 - \frac{1}{2} \cos x^2$  (c)  $y = 3 - \ln(\sqrt{2} \cos x)$

(d)  $y = -\frac{47}{15} - \frac{37}{5}(x - 2) + \frac{x^5}{30}$  (e)  $y = \frac{1}{4}xe^{2x} - \frac{1}{4}e^{2x} + \frac{29}{4}$

(f)  $y = x \sin x + 2 \cos x - 3x - 1$  (g)  $y = (x^2 - 6x + 12)e^x + \frac{x^2}{2} - 8x - 11$

(h)  $y = \frac{x^3}{3} + \frac{\cos 2x}{6} + \frac{7}{4}x^2 - 6x + \frac{7}{8}$  (i)  $y = \frac{x^4}{12} + \frac{x^3}{6} + \frac{1}{2}(x - 2)^2 - \frac{26}{3}(x - 2) - \frac{5}{3}$

1.2.7 (p. 15) (a) 576 ft (b) 10 s 1.2.8 (p. 15) (b)  $y = 0$  1.2.10 (p. 15) (a)  $(-2c - 2, \infty)$   $(-\infty, \infty)$

## Section 2.1 Answers, pp. 41–44

$$2.1.1 \text{ (p. 41)} \quad y = e^{-ax} \quad 2.1.2 \text{ (p. 41)} \quad y = ce^{-x^3} \quad 2.1.3 \text{ (p. 41)} \quad y = ce^{-(\ln x)^2/2}$$

$$2.1.4 \text{ (p. 41)} \quad y = \frac{c}{x^3} \quad 2.1.5 \text{ (p. 41)} \quad y = ce^{1/x} \quad 2.1.6 \text{ (p. 41)} \quad y = \frac{e^{-(x-1)}}{x} \quad 2.1.7 \text{ (p. 41)} \quad y = \frac{e}{x \ln x}$$

$$2.1.8 \text{ (p. 41)} \quad y = \frac{\pi}{x \sin x} \quad 2.1.9 \text{ (p. 41)} \quad y = 2(1+x^2) \quad 2.1.10 \text{ (p. 41)} \quad y = 3x^{-k}$$

$$2.1.11 \text{ (p. 41)} \quad y = c(\cos kx)^{1/k} \quad 2.1.12 \text{ (p. 41)} \quad y = \frac{1}{3} + ce^{-3x} \quad 2.1.13 \text{ (p. 41)} \quad y = \frac{2}{x} + \frac{c}{x}e^x$$

$$2.1.14 \text{ (p. 41)} \quad y = e^{-x^2} \left( \frac{x^2}{2} + c \right) \quad 2.1.15 \text{ (p. 41)} \quad y = -\frac{e^{-x} + c}{1+x^2} \quad 2.1.16 \text{ (p. 42)} \quad y = \frac{7 \ln|x|}{x} + \frac{3}{2}x + \frac{c}{x}$$

$$2.1.17 \text{ (p. 42)} \quad y = (x-1)^{-4} (\ln|x-1| - \cos x + c) \quad 2.1.18 \text{ (p. 42)} \quad y = e^{-x^2} \left( \frac{x^3}{4} + \frac{c}{x} \right)$$

$$2.1.19 \text{ (p. 42)} \quad y = \frac{2 \ln|x|}{x^2} + \frac{1}{2} + \frac{c}{x^2} \quad 2.1.20 \text{ (p. 42)} \quad y = (x+c) \cos x \quad 2.1.21 \text{ (p. 42)} \quad y = \frac{c - \cos x}{(1+x)^2}$$

$$2.1.22 \text{ (p. 42)} \quad y = -\frac{1}{2} \frac{(x-2)^3}{(x-1)} + c \frac{(x-2)^5}{(x-1)} \quad 2.1.23 \text{ (p. 42)} \quad y = (x+c)e^{-\sin^2 x}$$

$$2.1.24 \text{ (p. 42)} \quad y = \frac{e^x}{x^2} - \frac{e^x}{x^3} + \frac{c}{x^2} \cdot y = \frac{e^{3x} - e^{-7x}}{10} \quad 2.1.26 \text{ (p. 42)} \quad \frac{2x+1}{(1+x^2)^2}$$

$$2.1.27 \text{ (p. 42)} \quad y = \frac{1}{x^2} \ln \left( \frac{1+x^2}{2} \right) \quad 2.1.29 \text{ (p. 42)} \quad y = \frac{2 \ln|x|}{x} + \frac{x}{2} - \frac{1}{2x} \quad 2.1.28 \text{ (p. 42)} \quad y = \frac{1}{2} (\sin x + \csc x)$$

$$2.1.29 \text{ (p. 42)} \quad y = \frac{2 \ln|x|}{x} + \frac{x}{2} - \frac{1}{2x} \quad 2.1.30 \text{ (p. 42)} \quad y = (x-1)^{-3} [\ln(1-x) - \cos x]$$

$$2.1.31 \text{ (p. 42)} \quad y = 2x^2 + \frac{1}{x^2} \quad (0, \infty) \quad 2.1.32 \text{ (p. 42)} \quad y = x^2(1-\ln x) \quad 2.1.33 \text{ (p. 42)} \quad y = \frac{1}{2} + \frac{5}{2}e^{-x^2}$$

$$2.1.34 \text{ (p. 42)} \quad y = \frac{\ln|x-1| + \tan x + 1}{(x-1)^3} \quad 2.1.35 \text{ (p. 42)} \quad y = \frac{\ln|x| + x^2 + 1}{(x+2)^4}$$

$$2.1.36 \text{ (p. 42)} \quad y = (x^2 - 1) \left( \frac{1}{2} \ln|x^2 - 1| - 4 \right)$$

$$2.1.37 \text{ (p. 42)} \quad y = -(x^2 - 5) (7 + \ln|x^2 - 5|) \quad 2.1.38 \text{ (p. 42)} \quad y = e^{-x^2} \left( 3 + \int_0^x t^2 e^{t^2} dt \right)$$

$$2.1.39 \text{ (p. 42)} \quad y = \frac{1}{x} \left( 2 + \int_1^x \frac{\sin t}{t} dt \right) \quad 2.1.40 \text{ (p. 42)} \quad y = e^{-x} \int_1^x \frac{\tan t}{t} dt$$

$$2.1.41 \text{ (p. 43)} \quad y = \frac{1}{1+x^2} \left( 1 + \int_0^x \frac{e^t}{1+t^2} dt \right) \quad 2.1.42 \text{ (p. 43)} \quad y = \frac{1}{x} \left( 2e^{-(x-1)} + e^{-x} \int_1^x e^t e^{t^2} dt \right)$$

$$2.1.43 \text{ (p. 43)} \quad G = \frac{r}{\lambda} + \left(G_0 - \frac{r}{\lambda}\right) e^{-\lambda t} \quad \lim_{t \rightarrow \infty} G(t) = \frac{r}{\lambda} \quad 2.1.45 \text{ (p. 43)} \quad \text{(a)} \quad y = y_0 e^{-a(x-x_0)} + e^{-ax} \int_{x_0}^x e^{at} f(t) dt$$

$$2.1.48 \text{ (p. 44)} \quad \text{(a)} \quad y = \tan^{-1} \left( \frac{1}{3} + ce^{3x} \right) \quad \text{(b)} \quad y = \pm \left[ \ln \left( \frac{1}{x} + \frac{c}{x^2} \right) \right]^{1/2}$$

$$\text{(c)} \quad y = \exp \left( x^2 + \frac{c}{x^2} \right) \quad \text{(d)} \quad y = -1 + \frac{x}{c + 3 \ln |x|}$$

### Section 2.2 Answers, pp. 52–55

$$2.2.1 \text{ (p. 52)} \quad y = 2 \pm \sqrt{2(x^3 + x^2 + x + c)}$$

$$2.2.2 \text{ (p. 52)} \quad \ln(|\sin y|) = \cos x + c; \quad y \equiv k\pi, \quad k = \text{integer}$$

$$2.2.3 \text{ (p. 52)} \quad y = \frac{c}{x-c} \quad y \equiv -1 \quad 2.2.4 \text{ (p. 52)} \quad \frac{(\ln y)^2}{2} = -\frac{x^3}{3} + c$$

$$2.2.5 \text{ (p. 52)} \quad y^3 + 3 \sin y + \ln |y| + \ln(1+x^2) + \tan^{-1} x = c; \quad y \equiv 0$$

$$2.2.6 \text{ (p. 52)} \quad y = \pm \left( 1 + \left( \frac{x}{1+cx} \right)^2 \right)^{1/2}; \quad y \equiv \pm 1$$

$$2.2.7 \text{ (p. 52)} \quad y = \tan \left( \frac{x^3}{3} + c \right) \quad 2.2.8 \text{ (p. 52)} \quad y = \frac{c}{\sqrt{1+x^2}} \quad 2.2.9 \text{ (p. 52)} \quad y = \frac{2 - ce^{(x-1)^2/2}}{1 - ce^{(x-1)^2/2}}; \quad y \equiv 1$$

$$2.2.10 \text{ (p. 52)} \quad y = 1 + (3x^2 + 9x + c)^{1/3}$$

$$2.2.11 \text{ (p. 52)} \quad y = 2 + \sqrt{\frac{2}{3}x^3 + 3x^2 + 4x - \frac{11}{3}} \quad 2.2.12 \text{ (p. 52)} \quad y = \frac{e^{-(x^2-4)/2}}{2 - e^{-(x^2-4)/2}}$$

$$2.2.13 \text{ (p. 52)} \quad y^3 + 2y^2 + x^2 + \sin x = 3 \quad 2.2.14 \text{ (p. 53)} \quad (y+1)(y-1)^{-3}(y-2)^2 = -256(x+1)^{-6}$$

$$2.2.15 \text{ (p. 53)} \quad y = -1 + 3e^{-x^2} \quad 2.2.16 \text{ (p. 53)} \quad y = \frac{1}{\sqrt{2e^{-2x^2} - 1}} \quad 2.2.17 \text{ (p. 53)} \quad y \equiv -1; \quad (-\infty, \infty)$$

$$2.2.18 \text{ (p. 53)} \quad y = \frac{4 - e^{-x^2}}{2 - e^{-x^2}}; \quad (-\infty, \infty) \quad 2.2.19 \text{ (p. 53)} \quad y = \frac{-1 + \sqrt{4x^2 - 15}}{2}; \quad \left( \frac{\sqrt{15}}{2}, \infty \right)$$

$$2.2.20 \text{ (p. 53)} \quad y = \frac{2}{1 + e^{-2x}} \quad (-\infty, \infty) \quad 2.2.21 \text{ (p. 53)} \quad y = -\sqrt{25 - x^2}; \quad (-5, 5)$$

$$2.2.22 \text{ (p. 53)} \quad y \equiv 2, \quad (-\infty, \infty) \quad 2.2.23 \text{ (p. 53)} \quad y = 3 \left( \frac{x+1}{2x-4} \right)^{1/3}; \quad (-\infty, 2)$$



2.2.24 (p. 53)  $y = \frac{x+c}{1-cx}$  2.2.25 (p. 53)  $y = -x \cos c + \sqrt{1-x^2} \sin c; \quad y \equiv 1; y \equiv -1$

2.2.26 (p. 53)  $y = -x + 3\pi/2$  2.2.28 (p. 53)  $P = \frac{P_0}{\alpha P_0 + (1 - \alpha P_0)e^{-at}}; \lim_{t \rightarrow \infty} P(t) = 1/\alpha$

2.2.29 (p. 53)  $I = \frac{SI_0}{I_0 + (S - I_0)e^{-rSt}}$

2.2.30 (p. 53) If  $q = rS$  then  $I = \frac{I_0}{1 + rI_0t}$  and  $\lim_{t \rightarrow \infty} I(t) = 0$ . If  $q \neq rS$ , then  $I =$

$\frac{\alpha I_0}{I_0 + (\alpha - I_0)e^{-r\alpha t}}$ . If  $q < rS$ , then  $\lim_{t \rightarrow \infty} I(t) = \alpha = S - \frac{q}{r}$

if  $q > rS$ , then  $\lim_{t \rightarrow \infty} I(t) = 0$  2.2.34 (p. 55)  $f = ap$ , where  $a = \text{constant}$

2.2.35 (p. 55)  $y = e^{-x} (-1 \pm \sqrt{2x^2 + c})$  2.2.36 (p. 55)  $y = x^2 (-1 + \sqrt{x^2 + c})$

2.2.37 (p. 55)  $y = e^x (-1 + (3xe^x + c)^{1/3})$

2.2.38 (p. 55)  $y = e^{2x} (1 \pm \sqrt{c - x^2})$  2.2.39 (p. 55) (a)  $y_1 = 1/x; \quad g(x) = h(x)$

(b)  $y_1 = x; \quad g(x) = h(x)/x^2$  (c)  $y_1 = e^{-x}; \quad g(x) = e^x h(x)$

(d)  $y_1 = x^{-r}; \quad g(x) = x^{r-1} h(x)$  (e)  $y_1 = 1/v(x); \quad g(x) = v(x)h(x)$

**Section 2.3 Answers, pp. 60–62**

2.3.1 (p. 60) (a), (b)  $x_0 \neq k\pi$  ( $k = \text{integer}$ ) 2.3.2 (p. 60) (a), (b)  $(x_0, y_0) \neq (0, 0)$

2.3.3 (p. 61) (a), (b)  $x_0 y_0 \neq (2k + 1)\frac{\pi}{2}$  ( $k = \text{integer}$ ) 2.3.4 (p. 61) (a), (b)  $x_0 y_0 > 0$  and  $x_0 y_0 \neq 1$

2.3.5 (p. 61) (a) all  $(x_0, y_0)$  (b)  $(x_0, y_0)$  with  $y_0 \neq 0$  2.3.6 (p. 61) (a), (b) all  $(x_0, y_0)$

2.3.7 (p. 61) (a), (b) all  $(x_0, y_0)$  2.3.8 (p. 61) (a), (b)  $(x_0, y_0)$  such that  $x_0 \neq 4y_0$

2.3.9 (p. 61) (a) all  $(x_0, y_0)$  (b) all  $(x_0, y_0) \neq (0, 0)$  2.3.10 (p. 61) (a) all  $(x_0, y_0)$

(b) all  $(x_0, y_0)$  with  $y_0 \neq \pm 1$  2.3.11 (p. 61) (a), (b) all  $(x_0, y_0)$

**2.3.12 (p. 61)** (a), (b) all  $(x_0, y_0)$  such that  $x_0 + y_0 > 0$

**2.3.13 (p. 61)** (a), (b) all  $(x_0, y_0)$  with  $x_0 \neq 1$ ,  $y_0 \neq (2k+1)\frac{\pi}{2}$  ( $k = \text{integer}$ )

**2.3.16 (p. 61)**  $y = \left(\frac{3}{5}x + 1\right)^{5/3}$ ,  $-\infty < x < \infty$ , is a solution.

Also,

$$y = \begin{cases} 0, & -\infty < x \leq -\frac{5}{3} \\ \left(\frac{3}{5}x + 1\right)^{5/3}, & -\frac{5}{3} < x < \infty \end{cases}$$

is a solution. For every  $a \geq \frac{5}{3}$ , the following function is also a solution:

$$y = \begin{cases} \left(\frac{3}{5}(x+a)\right)^{5/3}, & -\infty < x < -a, \\ 0, & -a \leq x \leq -\frac{5}{3} \\ \left(\frac{3}{5}x + 1\right)^{5/3}, & -\frac{5}{3} < x < \infty. \end{cases}$$

**2.3.17 (p. 62)** (a) all  $(x_0, y_0)$  (b) all  $(x_0, y_0)$  with  $y_0 \neq 1$

**2.3.18 (p. 62)**  $y_1 \equiv 1$ ;  $y_2 = 1 + |x|^3$ ;  $y_3 = 1 - |x|^3$ ;  $y_4 = 1 + x^3$ ;  $y_5 = 1 - x^3$

$$y_6 = \begin{cases} 1 + x^3, & x \geq 0, \\ 1, & x < 0 \end{cases}; \quad y_7 = \begin{cases} 1 - x^3, & x \geq 0, \\ 1, & x < 0 \end{cases};$$

$$y_8 = \begin{cases} 1, & x \geq 0, \\ 1 + x^3, & x < 0 \end{cases}; \quad y_9 = \begin{cases} 1, & x \geq 0, \\ 1 - x^3, & x < 0 \end{cases}$$

**2.3.19 (p. 62)**  $y = 1 + (x^2 + 4)^{3/2}$ ,  $-\infty < x < \infty$

**2.3.20 (p. 62)** (a) The solution is unique on  $(0, \infty)$ . It is given by

$$y = \begin{cases} 1, & 0 < x \leq \sqrt{5}, \\ 1 - (x^2 - 5)^{3/2}, & \sqrt{5} < x < \infty \end{cases}$$

(b)

$$y = \begin{cases} 1, & -\infty < x \leq \sqrt{5}, \\ 1 - (x^2 - 5)^{3/2}, & \sqrt{5} < x < \infty \end{cases}$$

is a solution of (A) on  $(-\infty, \infty)$ . If  $\alpha \geq 0$ , then

$$y = \begin{cases} 1 + (x^2 - \alpha^2)^{3/2}, & -\infty < x < -\alpha, \\ 1, & -\alpha \leq x \leq \sqrt{5}, \\ 1 - (x^2 - 5)^{3/2}, & \sqrt{5} < x < \infty, \end{cases}$$

and

$$y = \begin{cases} 1 - (x^2 - \alpha^2)^{3/2}, & -\infty < x < -\alpha, \\ 1, & -\alpha \leq x \leq \sqrt{5}, \\ 1 - (x^2 - 5)^{3/2}, & \sqrt{5} < x < \infty, \end{cases}$$

are also solutions of (A) on  $(-\infty, \infty)$ .

### Section 2.4 Answers, pp. 68–72

2.4.1 (p. 68)  $y = \frac{1}{1 - ce^x}$  2.4.2 (p. 68)  $y = x^{2/7}(c - \ln|x|)^{1/7}$  2.4.3 (p. 68)  $y = e^{2/x}(c - 1/x)^2$

2.4.4 (p. 68)  $y = \pm \frac{\sqrt{2x+c}}{1+x^2}$  2.4.5 (p. 68)  $y = \pm(1 - x^2 + ce^{-x^2})^{-1/2}$

2.4.6 (p. 68)  $y = \left[ \frac{x}{3(1-x) + ce^{-x}} \right]^{1/3}$  2.4.7 (p. 69)  $y = \frac{2\sqrt{2}}{\sqrt{1-4x}}$  2.4.8 (p. 69)  $y = \left[ 1 - \frac{3}{2}e^{-(x^2-1)/4} \right]^{-2}$

2.4.9 (p. 69)  $y = \frac{1}{x(11-3x)^{1/3}}$  2.4.10 (p. 69)  $y = (2e^x - 1)^2$

2.4.11 (p. 69)  $y = (2e^{12x} - 1 - 12x)^{1/3}$  2.4.12 (p. 69)  $y = \left[ \frac{5x}{2(1+4x^5)} \right]^{1/2}$

2.4.13 (p. 69)  $y = (4e^{x/2} - x - 2)^2$

2.4.14 (p. 69)  $P = \frac{P_0 e^{at}}{1 + aP_0 \int_0^t \alpha(\tau) e^{a\tau} d\tau}$ ;  $\lim_{t \rightarrow \infty} P(t) = \begin{cases} \infty & \text{if } L = 0, \\ 0 & \text{if } L = \infty, \\ 1/aL & \text{if } 0 < L < \infty. \end{cases}$

2.4.15 (p. 69)  $y = x(\ln|x| + c)$  2.4.16 (p. 69)  $y = \frac{cx^2}{1-cx}$   $y = -x$

2.4.17 (p. 69)  $y = \pm x(4 \ln|x| + c)^{1/4}$  2.4.18 (p. 69)  $y = x \sin^{-1}(\ln|x| + c)$

2.4.19 (p. 69)  $y = x \tan(\ln|x| + c)$  2.4.20 (p. 69)  $y = \pm x \sqrt{cx^2 - 1}$

2.4.21 (p. 70)  $y = \pm x \ln(\ln|x| + c)$  2.4.22 (p. 70)  $y = -\frac{2x}{2 \ln|x| + 1}$

2.4.23 (p. 70)  $y = x(3 \ln x + 27)^{1/3}$  2.4.24 (p. 70)  $y = \frac{1}{x} \left( \frac{9-x^4}{2} \right)^{1/2}$  2.4.25 (p. 70)  $y = -x$

$$2.4.26 \text{ (p. 70)} \quad y = -\frac{x(4x-3)}{(2x-3)} \quad 2.4.27 \text{ (p. 70)} \quad y = x\sqrt{4x^6-1} \quad 2.4.28 \text{ (p. 70)} \quad \tan^{-1} \frac{y}{x} - \frac{1}{2} \ln(x^2+y^2) = c$$

$$2.4.29 \text{ (p. 70)} \quad (x+y) \ln|x| + y(1 - \ln|y|) + cx = 0 \quad 2.4.30 \text{ (p. 70)} \quad (y+x)^3 = 3x^3(\ln|x|+c)$$

$$2.4.31 \text{ (p. 70)} \quad (y+x) = c(y-x)^3; \quad y = x; \quad y = -x$$

$$2.4.32 \text{ (p. 70)} \quad y^2(y-3x) = c; \quad y \equiv 0; \quad y = 3x$$

$$2.4.33 \text{ (p. 70)} \quad (x-y)^3(x+y) = cy^2x^4; \quad y = 0; \quad y = x; \quad y = -x \quad 2.4.34 \text{ (p. 70)} \quad \frac{y}{x} + \frac{y^3}{x^3} = \ln|x|+c$$

2.4.40 (p. 71) Choose  $X_0$  and  $Y_0$  so that

$$\begin{aligned} aX_0 + bY_0 &= \alpha \\ cX_0 + dY_0 &= \beta. \end{aligned}$$

$$2.4.41 \text{ (p. 72)} \quad (y+2x+1)^4(2y-6x-3) = c; \quad y = 3x+3/2; \quad y = -2x-1$$

$$2.4.42 \text{ (p. 72)} \quad (y+x-1)(y-x-5)^3 = c; \quad y = x+5; \quad y = -x+1$$

$$2.4.43 \text{ (p. 72)} \quad \ln|y-x-6| - \frac{2(x+2)}{y-x-6} = c; \quad y = x+6 \quad 2.4.44 \text{ (p. 72)} \quad (y_1 = x^{1/3}) \quad y =$$

$$x^{1/3}(\ln|x|+c)^{1/3}$$

$$2.4.45 \text{ (p. 72)} \quad y_1 = x^3; \quad y = \pm x^3\sqrt{cx^6-1} \quad 2.4.46 \text{ (p. 72)} \quad y_1 = x^2; \quad y = \frac{x^2(1+cx^4)}{1-cx^4} \quad y = -x^2$$

$$2.4.47 \text{ (p. 72)} \quad y_1 = e^x; \quad y = -\frac{e^x(1-2ce^x)}{1-ce^x}; \quad y = -2e^x$$

$$2.4.48 \text{ (p. 72)} \quad y_1 = \tan x; \quad y = \tan x \tan(\ln|\tan x|+c)$$

$$2.4.49 \text{ (p. 72)} \quad y_1 = \ln x; \quad y = \frac{2 \ln x (1 + c(\ln x)^4)}{1 - c(\ln x)^4}; \quad y = -2 \ln x$$

$$2.4.50 \text{ (p. 72)} \quad y_1 = x^{1/2}; \quad y = x^{1/2}(-2 \pm \sqrt{\ln|x|+c})$$

$$2.4.51 \text{ (p. 72)} \quad y_1 = e^{x^2}; \quad y = e^{x^2}(-1 \pm \sqrt{2x^2+c}) \quad 2.4.52 \text{ (p. 72)} \quad y = \frac{-3 + \sqrt{1+60x}}{2x}$$

$$2.4.53 \text{ (p. 72)} \quad y = \frac{-5 + \sqrt{1+48x}}{2x^2} \quad 2.4.56 \text{ (p. 72)} \quad y = 1 + \frac{1}{x+1+ce^x}$$

2.4.57 (p. 72)  $y = e^x - \frac{1}{1 + ce^{-x}}$  2.4.58 (p. 72)  $y = 1 - \frac{1}{x(1 - cx)}$  2.4.59 (p. 72)  $y = x - \frac{2x}{x^2 + c}$

## Section 2.5 Answers, pp. 79–82

2.5.1 (p. 79)  $2x^3y^2 = c$  2.5.2 (p. 79)  $3y \sin x + 2x^2e^x + 3y = c$  2.5.3 (p. 79) Not exact

2.5.4 (p. 79)  $x^2 - 2xy^2 + 4y^3 = c$  2.5.5 (p. 79)  $x + y = c$  2.5.6 (p. 79) Not exact

2.5.7 (p. 79)  $2y^2 \cos x + 3xy^3 - x^2 = c$  2.5.8 (p. 79) Not exact

2.5.9 (p. 79)  $x^3 + x^2y + 4xy^2 + 9y^2 = c$  2.5.10 (p. 79) Not exact 2.5.11 (p. 79)  $\ln |xy| + x^2 + y^2 = c$

2.5.12 (p. 79) Not exact 2.5.13 (p. 79)  $x^2 + y^2 = c$  2.5.14 (p. 79)  $x^2y^2e^x + 2y + 3x^2 = c$

2.5.15 (p. 79)  $x^3e^{x^2+y} - 4y^3 + 2x^2 = c$  2.5.16 (p. 79)  $x^4e^{xy} + 3xy = c$

2.5.17 (p. 79)  $x^3 \cos xy + 4y^2 + 2x^2 = c$  2.5.18 (p. 79)  $y = \frac{x + \sqrt{2x^2 + 3x - 1}}{x^2}$

2.5.19 (p. 79)  $y = \sin x - \sqrt{1 - \frac{\tan x}{2}}$  2.5.20 (p. 79)  $y = \left(\frac{e^x - 1}{e^x + 1}\right)^{1/3}$

2.5.21 (p. 79)  $y = 1 + 2 \tan x$  2.5.22 (p. 79)  $y = \frac{x^2 - x + 6}{(x + 2)(x - 3)}$

2.5.23 (p. 80)  $\frac{7x^2}{2} + 4xy + \frac{3y^2}{2} = c$  2.5.24 (p. 80)  $(x^4y^2 + 1)e^x + y^2 = c$

2.5.29 (p. 81) (a)  $M(x, y) = 2xy + f(x)$  (b)  $M(x, y) = 2(\sin x + x \cos x)(y \sin y + \cos y) + f(x)$

(c)  $M(x, y) = ye^x - e^y \cos x + f(x)$

2.5.30 (p. 81) (a)  $N(x, y) = \frac{x^4y}{2} + x^2 + 6xy + g(y)$  (b)  $N(x, y) = \frac{x}{y} + 2y \sin x + g(y)$

(c)  $N(x, y) = x(\sin y + y \cos y) + g(y)$

2.5.33 (p. 81)  $B = C$  2.5.34 (p. 81)  $B = 2D, \quad E = 2C$

2.5.37 (p. 82) (a)  $2x^2 + x^4y^4 + y^2 = c$  (b)  $x^3 + 3xy^2 = c$  (c)  $x^3 + y^2 + 2xy = c$

2.5.38 (p. 82)  $y = -1 - \frac{1}{x^2}$  2.5.39 (p. 82)  $y = x^3 \left( \frac{-3(x^2 + 1) + \sqrt{9x^4 + 34x^2 + 21}}{2} \right)$

$$2.5.40 \text{ (p. 82)} \quad y = -e^{-x^2} \left( \frac{2x + \sqrt{9 - 5x^2}}{3} \right).$$

$$2.5.44 \text{ (p. 82)} \quad \text{(a)} G(x, y) = 2xy + c \quad \text{(b)} G(x, y) = e^x \sin y + c$$

$$\text{(c)} G(x, y) = 3x^2y - y^3 + c \quad \text{(d)} G(x, y) = -\sin x \sinh y + c$$

$$\text{(e)} G(x, y) = \cos x \sinh y + c$$

### Section 2.6 Answers, pp. 91–93

$$2.6.3 \text{ (p. 91)} \quad \mu(x) = 1/x^2; \quad y = cx \text{ and } \mu(y) = 1/y^2; \quad x = cy$$

$$2.6.4 \text{ (p. 91)} \quad \mu(x) = x^{-3/2}; \quad x^{3/2}y = c \quad 2.6.5 \text{ (p. 91)} \quad \mu(y) = 1/y^3; \quad y^3e^{2x} = c$$

$$2.6.6 \text{ (p. 91)} \quad \mu(x) = e^{5x/2}; \quad e^{5x/2}(xy + 1) = c \quad 2.6.7 \text{ (p. 92)} \quad \mu(x) = e^x; \quad e^x(xy + y + x) = c$$

$$2.6.8 \text{ (p. 92)} \quad \mu(x) = x; \quad x^2y^2(9x + 4y) = c \quad 2.6.9 \text{ (p. 92)} \quad \mu(y) = y^2; \quad y^3(3x^2y + 2x + 1) = c \quad 2.6.10$$

$$\text{(p. 92)} \quad \mu(y) = ye^y; \quad e^y(xy^3 + 1) = c \quad 2.6.11 \text{ (p. 92)} \quad \mu(y) = y^2; \quad y^3(3x^4 + 8x^3y + y) = c$$

$$2.6.12 \text{ (p. 92)} \quad \mu(x) = xe^x; \quad x^2y(x + 1)e^x = c$$

$$2.6.13 \text{ (p. 92)} \quad \mu(x) = (x^3 - 1)^{-4/3}; \quad xy(x^3 - 1)^{-1/3} = c \text{ and } x \equiv 1$$

$$2.6.14 \text{ (p. 92)} \quad \mu(y) = e^y; \quad e^y(\sin x \cos y + y - 1) = c \quad 2.6.15 \text{ (p. 92)} \quad \mu(y) = e^{-y^2}; \quad xye^{-y^2}(x + y) = c$$

$$2.6.16 \text{ (p. 92)} \quad \frac{xy}{\sin y} = c \text{ and } y = k\pi \quad (k = \text{integer}) \quad 2.6.17 \text{ (p. 92)} \quad \mu(x, y) = x^4y^3; \quad x^5y^4 \ln x = c$$

$$2.6.18 \text{ (p. 92)} \quad \mu(x, y) = 1/xy; \quad |x|^\alpha |y|^\beta e^{\gamma x} e^{\delta y} = c \text{ and } x \equiv 0, y \equiv 0$$

$$2.6.19 \text{ (p. 92)} \quad \mu(x, y) = x^{-2}y^{-3}; \quad 3x^2y^2 + y = 1 + cxy^2 \text{ and } x \equiv 0, y \equiv 0$$

$$2.6.20 \text{ (p. 92)} \quad \mu(x, y) = x^{-2}y^{-1}; \quad -\frac{2}{x} + y^3 + 3 \ln |y| = c \text{ and } x \equiv 0, y \equiv 0$$

$$2.6.21 \text{ (p. 92)} \quad \mu(x, y) = e^{ax}e^{by}; \quad e^{ax}e^{by} \cos xy = c$$

**2.6.22 (p. 92)**  $\mu(x, y) = x^{-4}y^{-3}$  (and others)  $xy = c$  **2.6.23 (p. 92)**  $\mu(x, y) = xe^y; x^2ye^y \sin x = c$

**2.6.24 (p. 92)**  $\mu(x) = 1/x^2; \frac{x^3y^3}{3} - \frac{y}{x} = c$  **2.6.25 (p. 92)**  $\mu(x) = x + 1; y(x + 1)^2(x + y) = c$

**2.6.26 (p. 92)**  $\mu(x, y) = x^2y^2; x^3y^3(3x + 2y^2) = c$

**2.6.27 (p. 92)**  $\mu(x, y) = x^{-2}y^{-2}; 3x^2y = cxy + 2$  and  $x \equiv 0, y \equiv 0$

**Section 3.1 Answers, pp. 106–108**

**3.1.1 (p. 106)**  $y_1 = 1.450000000, y_2 = 2.085625000, y_3 = 3.079099746$

**3.1.2 (p. 106)**  $y_1 = 1.200000000, y_2 = 1.440415946, y_3 = 1.729880994$

**3.1.3 (p. 106)**  $y_1 = 1.900000000, y_2 = 1.781375000, y_3 = 1.646612970$

**3.1.4 (p. 106)**  $y_1 = 2.962500000, y_2 = 2.922635828, y_3 = 2.880205639$

**3.1.5 (p. 106)**  $y_1 = 2.513274123, y_2 = 1.814517822, y_3 = 1.216364496$

**3.1.6 (p. 106)**

$x$	$h = 0.1$	$h = 0.05$	$h = 0.025$	Exact
1.0	48.298147362	51.492825643	53.076673685	54.647937102

**3.1.7 (p. 106)**

$x$	$h = 0.1$	$h = 0.05$	$h = 0.025$	Exact
2.0	1.390242009	1.370996758	1.361921132	1.353193719

**3.1.8 (p. 107)**

$x$	$h = 0.05$	$h = 0.025$	$h = 0.0125$	Exact
1.50	7.886170437	8.852463793	9.548039907	10.500000000

**3.1.9 (p. 107)**

$x$	$h = 0.1$	$h = 0.05$	$h = 0.025$	$h = 0.1$	$h = 0.05$	$h = 0.025$
3.0	1.469458241	1.462514486	1.459217010	0.3210	0.1537	0.0753
	Approximate Solutions			Residuals		

**3.1.10 (p. 107)**

$x$	$h = 0.1$	$h = 0.05$	$h = 0.025$	$h = 0.1$	$h = 0.05$	$h = 0.025$
2.0	0.473456737	0.483227470	0.487986391	-0.3129	-0.1563	-0.0781
	Approximate Solutions			Residuals		

**3.1.11 (p. 107)**

$x$	$h = 0.1$	$h = 0.05$	$h = 0.025$	“Exact”
1.0	0.691066797	0.676269516	0.668327471	0.659957689



**3.1.12 (p. 108)**

$x$	$h = 0.1$	$h = 0.05$	$h = 0.025$	"Exact"
2.0	-0.772381768	-0.761510960	-0.756179726	-0.750912371

**3.1.13 (p. 108)**

Euler's method				
$x$	$h = 0.1$	$h = 0.05$	$h = 0.025$	Exact
1.0	0.538871178	0.593002325	0.620131525	0.647231889

Euler semilinear method				
$x$	$h = 0.1$	$h = 0.05$	$h = 0.025$	Exact
1.0	0.647231889	0.647231889	0.647231889	0.647231889

Applying variation of parameters to the given initial value problem yields

$y = ue^{-3x}$ , where (A)  $u' = 7$ ,  $u(0) = 6$ . Since  $u'' = 0$ , Euler's method yields the exact solution of (A). Therefore the Euler semilinear method produces the exact solution of the given problem

**3.1.14 (p. 108)**

Euler's method				
$x$	$h = 0.1$	$h = 0.05$	$h = 0.025$	"Exact"
3.0	12.804226135	13.912944662	14.559623055	15.282004826

Euler semilinear method				
$x$	$h = 0.1$	$h = 0.05$	$h = 0.025$	"Exact"
3.0	15.354122287	15.317257705	15.299429421	15.282004826

**3.1.15 (p. 108)**

Euler's method				
$x$	$h = 0.2$	$h = 0.1$	$h = 0.05$	"Exact"
2.0	0.867565004	0.885719263	0.895024772	0.904276722

Euler semilinear method				
$x$	$h = 0.2$	$h = 0.1$	$h = 0.05$	"Exact"
2.0	0.569670789	0.720861858	0.808438261	0.904276722

**3.1.16 (p. 108)**

Euler's method				
$x$	$h = 0.2$	$h = 0.1$	$h = 0.05$	"Exact"
3.0	0.922094379	0.945604800	0.956752868	0.967523153

Euler semilinear method				
$x$	$h = 0.2$	$h = 0.1$	$h = 0.05$	"Exact"
3.0	0.993954754	0.980751307	0.974140320	0.967523153

**3.1.17 (p. 108)**

Euler's method				
$x$	$h = 0.0500$	$h = 0.0250$	$h = 0.0125$	"Exact"
1.50	0.319892131	0.330797109	0.337020123	0.343780513

Euler semilinear method				
$x$	$h = 0.0500$	$h = 0.0250$	$h = 0.0125$	"Exact"
1.50	0.305596953	0.323340268	0.333204519	0.343780513

**3.1.18 (p. 108)**

Euler's method				
$x$	$h = 0.2$	$h = 0.1$	$h = 0.05$	"Exact"
2.0	0.754572560	0.743869878	0.738303914	0.732638628

Euler semilinear method				
$x$	$h = 0.2$	$h = 0.1$	$h = 0.05$	"Exact"
2.0	0.722610454	0.727742966	0.730220211	0.732638628

**3.1.19 (p. 108)**

Euler's method				
$x$	$h = 0.0500$	$h = 0.0250$	$h = 0.0125$	"Exact"
1.50	2.175959970	2.210259554	2.227207500	2.244023982

Euler semilinear method				
$x$	$h = 0.0500$	$h = 0.0250$	$h = 0.0125$	"Exact"
1.50	2.117953342	2.179844585	2.211647904	2.244023982

**3.1.20 (p. 108)**

Euler's method				
$x$	$h = 0.1$	$h = 0.05$	$h = 0.025$	"Exact"
1.0	0.032105117	0.043997045	0.050159310	0.056415515

Euler semilinear method				
$x$	$h = 0.1$	$h = 0.05$	$h = 0.025$	"Exact"
1.0	0.056020154	0.056243980	0.056336491	0.056415515

**3.1.21 (p. 108)**

Euler's method				
$x$	$h = 0.1$	$h = 0.05$	$h = 0.025$	"Exact"
1.0	28.987816656	38.426957516	45.367269688	54.729594761

Euler semilinear method				
$x$	$h = 0.1$	$h = 0.05$	$h = 0.025$	"Exact"
1.0	54.709134946	54.724150485	54.728228015	54.729594761

**3.1.22 (p. 108)**

Euler's method				
$x$	$h = 0.1$	$h = 0.05$	$h = 0.025$	"Exact"
3.0	1.361427907	1.361320824	1.361332589	1.361383810

Euler semilinear method				
$x$	$h = 0.1$	$h = 0.05$	$h = 0.025$	"Exact"
3.0	1.291345518	1.326535737	1.344004102	1.361383810

Section 3.2 Answers, pp. 116–108

3.2.1 (p. 116)  $y_1 = 1.542812500$ ,  $y_2 = 2.421622101$ ,  $y_3 = 4.208020541$

3.2.2 (p. 116)  $y_1 = 1.220207973$ ,  $y_2 = 1.489578775$ ,  $y_3 = 1.819337186$

3.2.3 (p. 116)  $y_1 = 1.890687500$ ,  $y_2 = 1.763784003$ ,  $y_3 = 1.622698378$

3.2.4 (p. 116)  $y_1 = 2.961317914$ ,  $y_2 = 2.920132727$ ,  $y_3 = 2.876213748$ .

3.2.5 (p. 116)  $y_1 = 2.478055238$ ,  $y_2 = 1.844042564$ ,  $y_3 = 1.313882333$

3.2.6 (p. 116)

$x$	$h = 0.1$	$h = 0.05$	$h = 0.025$	Exact
1.0	56.134480009	55.003390448	54.734674836	54.647937102

3.2.7 (p. 116)

$x$	$h = 0.1$	$h = 0.05$	$h = 0.025$	Exact
2.0	1.353501839	1.353288493	1.353219485	1.353193719

3.2.8 (p. 117)

$x$	$h = 0.05$	$h = 0.025$	$h = 0.0125$	Exact
1.50	10.141969585	10.396770409	10.472502111	10.500000000

3.2.9 (p. 117)

$x$	$h = 0.1$	$h = 0.05$	$h = 0.025$	$h = 0.1$	$h = 0.05$	$h = 0.025$
3.0	1.455674816	1.455935127	1.456001289	-0.00818	-0.00207	-0.000518
	Approximate Solutions			Residuals		

3.2.10 (p. 117)

$x$	$h = 0.1$	$h = 0.05$	$h = 0.025$	$h = 0.1$	$h = 0.05$	$h = 0.025$
2.0	0.492862999	0.492709931	0.492674855	0.00335	0.000777	0.000187
	Approximate Solutions			Residuals		

3.2.11 (p. 117)

$x$	$h = 0.1$	$h = 0.05$	$h = 0.025$	"Exact"
1.0	0.660268159	0.660028505	0.659974464	0.659957689

3.2.12 (p. 118)

$x$	$h = 0.1$	$h = 0.05$	$h = 0.025$	"Exact"
2.0	-0.749751364	-0.750637632	-0.750845571	-0.750912371

3.2.13 (p. 118) Applying variation of parameters to the given initial value problem

$y = ue^{-3x}$ , where (A)  $u' = 1 - 2x$ ,  $u(0) = 2$ . Since  $u''' = 0$ , the improved Euler method yields the exact solution of (A). Therefore the improved Euler semilinear method produces the exact solution of the given problem.

Improved Euler method				
$x$	$h = 0.1$	$h = 0.05$	$h = 0.025$	Exact
1.0	0.105660401	0.100924399	0.099893685	0.099574137

Improved Euler semilinear method				
$x$	$h = 0.1$	$h = 0.05$	$h = 0.025$	Exact
1.0	0.099574137	0.099574137	0.099574137	0.099574137

3.2.14 (p. 118)

Improved Euler method				
$x$	$h = 0.1$	$h = 0.05$	$h = 0.025$	"Exact"
3.0	15.107600968	15.234856000	15.269755072	15.282004826

Improved Euler semilinear method				
$x$	$h = 0.1$	$h = 0.05$	$h = 0.025$	"Exact"
3.0	15.285231726	15.282812424	15.282206780	15.282004826

**3.2.15 (p. 118)**

Improved Euler method				
$x$	$h = 0.2$	$h = 0.1$	$h = 0.05$	"Exact"
2.0	0.924335375	0.907866081	0.905058201	0.904276722

Improved Euler semilinear method				
$x$	$h = 0.2$	$h = 0.1$	$h = 0.05$	"Exact"
2.0	0.969670789	0.920861858	0.908438261	0.904276722

**3.2.16 (p. 118)**

Improved Euler method				
$x$	$h = 0.2$	$h = 0.1$	$h = 0.05$	"Exact"
3.0	0.967473721	0.967510790	0.967520062	0.967523153

Improved Euler semilinear method				
$x$	$h = 0.2$	$h = 0.1$	$h = 0.05$	"Exact"
3.0	0.967473721	0.967510790	0.967520062	0.967523153

**3.2.17 (p. 118)**

Improved Euler method				
$x$	$h = 0.0500$	$h = 0.0250$	$h = 0.0125$	"Exact"
1.50	0.349176060	0.345171664	0.344131282	0.343780513

Improved Euler semilinear method				
$x$	$h = 0.0500$	$h = 0.0250$	$h = 0.0125$	"Exact"
1.50	0.349350206	0.345216894	0.344142832	0.343780513

**3.2.18 (p. 118)**

Improved Euler method				
$x$	$h = 0.2$	$h = 0.1$	$h = 0.05$	"Exact"
2.0	0.732679223	0.732721613	0.732667905	0.732638628

Improved Euler semilinear method				
$x$	$h = 0.2$	$h = 0.1$	$h = 0.05$	"Exact"
2.0	0.732166678	0.732521078	0.732609267	0.732638628

**3.2.19 (p. 118)**

Improved Euler method				
$x$	$h = 0.0500$	$h = 0.0250$	$h = 0.0125$	"Exact"
1.50	2.247880315	2.244975181	2.244260143	2.244023982

Improved Euler semilinear method				
$x$	$h = 0.0500$	$h = 0.0250$	$h = 0.0125$	"Exact"
1.50	2.248603585	2.245169707	2.244310465	2.244023982

**3.2.20 (p. 118)**

Improved Euler method				
$x$	$h = 0.1$	$h = 0.05$	$h = 0.025$	"Exact"
1.0	0.059071894	0.056999028	0.056553023	0.056415515

Improved Euler semilinear method				
$x$	$h = 0.1$	$h = 0.05$	$h = 0.025$	"Exact"
1.0	0.056295914	0.056385765	0.056408124	0.056415515

**3.2.21 (p. 118)**

Improved Euler method				
$x$	$h = 0.1$	$h = 0.05$	$h = 0.025$	"Exact"
1.0	50.534556346	53.483947013	54.391544440	54.729594761

Improved Euler semilinear method				
$x$	$h = 0.1$	$h = 0.05$	$h = 0.025$	"Exact"
1.0	54.709041434	54.724083572	54.728191366	54.729594761

**3.2.22 (p. 118)**

Improved Euler method				
$x$	$h = 0.1$	$h = 0.05$	$h = 0.025$	"Exact"
3.0	1.361395309	1.361379259	1.361382239	1.361383810

Improved Euler semilinear method				
$x$	$h = 0.1$	$h = 0.05$	$h = 0.025$	"Exact"
3.0	1.375699933	1.364730937	1.362193997	1.361383810

**3.2.23 (p. 118)**

$x$	$h = 0.1$	$h = 0.05$	$h = 0.025$	Exact
2.0	1.349489056	1.352345900	1.352990822	1.353193719

**3.2.24 (p. 118)**

$x$	$h = 0.1$	$h = 0.05$	$h = 0.025$	Exact
2.0	1.350890736	1.352667599	1.353067951	1.353193719

**3.2.25 (p. 118)**

$x$	$h = 0.05$	$h = 0.025$	$h = 0.0125$	Exact
1.50	10.133021311	10.391655098	10.470731411	10.500000000

**3.2.26 (p. 118)**

$x$	$h = 0.05$	$h = 0.025$	$h = 0.0125$	Exact
1.50	10.136329642	10.393419681	10.470731411	10.500000000

**3.2.27 (p. 118)**

$x$	$h = 0.1$	$h = 0.05$	$h = 0.025$	"Exact"
1.0	0.660846835	0.660189749	0.660016904	0.659957689

**3.2.28 (p. 119)**

$x$	$h = 0.1$	$h = 0.05$	$h = 0.025$	"Exact"
1.0	0.660658411	0.660136630	0.660002840	0.659957689

**3.2.29 (p. 119)**

$x$	$h = 0.1$	$h = 0.05$	$h = 0.025$	"Exact"
2.0	-0.750626284	-0.750844513	-0.750895864	-0.751331499

**3.2.30 (p. 119)**

$x$	$h = 0.1$	$h = 0.05$	$h = 0.025$	"Exact"
2.0	-0.750335016	-0.750775571	-0.750879100	-0.751331499

**Section 3.3 Answers, pp. 124–127**

**3.3.1 (p. 124)**  $y_1 = 1.550598190$ ,  $y_2 = 2.469649729$    **3.3.2 (p. 124)**  $y_1 = 1.221551366$ ,  $y_2 = 1.492920208$

**3.3.3 (p. 124)**  $y_1 = 1.890339767$ ,  $y_2 = 1.763094323$    **3.3.4 (p. 124)**  $y_1 = 2.961316248$ ,  $y_2 = 2.920128958$ .

**3.3.5 (p. 124)**  $y_1 = 2.475605264$ ,  $y_2 = 1.825992433$

**3.3.6 (p. 124)**

$x$	$h = 0.1$	$h = 0.05$	$h = 0.025$	Exact
1.0	54.654509699	54.648344019	54.647962328	54.647937102

**3.3.7 (p. 124)**

$x$	$h = 0.1$	$h = 0.05$	$h = 0.025$	Exact
2.0	1.353191745	1.353193606	1.353193712	1.353193719

**3.3.8 (p. 125)**

$x$	$h = 0.05$	$h = 0.025$	$h = 0.0125$	Exact
1.50	10.498658198	10.499906266	10.499993820	10.500000000

**3.3.9 (p. 125)**

$x$	$h = 0.1$	$h = 0.05$	$h = 0.025$	$h = 0.1$	$h = 0.05$	$h = 0.025$
3.0	1.456023907	1.456023403	1.456023379	0.0000124	0.000000611	0.0000000333
	Approximate Solutions			Residuals		

**3.3.10 (p. 125)**

$x$	$h = 0.1$	$h = 0.05$	$h = 0.025$	$h = 0.1$	$h = 0.05$	$h = 0.025$
2.0	0.492663789	0.492663738	0.492663736	0.000000902	0.0000000508	0.00000000302
	Approximate Solutions			Residuals		

**3.3.11 (p. 125)**

$x$	$h = 0.1$	$h = 0.05$	$h = 0.025$	"Exact"
1.0	0.659957046	0.659957646	0.659957686	0.659957689

**3.3.12 (p. 126)**

$x$	$h = 0.1$	$h = 0.05$	$h = 0.025$	"Exact"
2.0	-0.750911103	-0.750912294	-0.750912367	-0.750912371

**3.3.13 (p. 126)** Applying variation of parameters to the given initial value problem yields

$y = ue^{-3x}$ , where (A)  $u' = 1 - 4x + 3x^2 - 4x^3$ ,  $u(0) = -3$ . Since  $u^{(5)} = 0$ , the Runge-Kutta method yields the exact solution of (A). Therefore the Euler semilinear method produces the exact solution of the given problem.

Runge-Kutta method				
$x$	$h = 0.1$	$h = 0.05$	$h = 0.025$	Exact
0.0	-3.000000000	-3.000000000	-3.000000000	-3.000000000
0.1	-2.162598011	-2.162526572	-2.162522707	-2.162522468
0.2	-1.577172164	-1.577070939	-1.577065457	-1.577065117
0.3	-1.163350794	-1.163242678	-1.163236817	-1.163236453
0.4	-0.868030294	-0.867927182	-0.867921588	-0.867921241
0.5	-0.655542739	-0.655450183	-0.655445157	-0.655444845
0.6	-0.501535352	-0.501455325	-0.501450977	-0.501450707
0.7	-0.389127673	-0.389060213	-0.389056546	-0.389056318
0.8	-0.306468018	-0.306412184	-0.306409148	-0.306408959
0.9	-0.245153433	-0.245107859	-0.245105379	-0.245105226
1.0	-0.199187198	-0.199150401	-0.199148398	-0.199148273

Runge-Kutta semilinear method				
$x$	$h = 0.1$	$h = 0.05$	$h = 0.025$	Exact
0.0	-3.000000000	-3.000000000	-3.000000000	-3.000000000
0.1	-2.162522468	-2.162522468	-2.162522468	-2.162522468
0.2	-1.577065117	-1.577065117	-1.577065117	-1.577065117
0.3	-1.163236453	-1.163236453	-1.163236453	-1.163236453
0.4	-0.867921241	-0.867921241	-0.867921241	-0.867921241
0.5	-0.655444845	-0.655444845	-0.655444845	-0.655444845
0.6	-0.501450707	-0.501450707	-0.501450707	-0.501450707
0.7	-0.389056318	-0.389056318	-0.389056318	-0.389056318
0.8	-0.306408959	-0.306408959	-0.306408959	-0.306408959
0.9	-0.245105226	-0.245105226	-0.245105226	-0.245105226
1.0	-0.199148273	-0.199148273	-0.199148273	-0.199148273

**3.3.14 (p. 126)**

Runge-Kutta method				
$x$	$h = 0.1$	$h = 0.05$	$h = 0.025$	"Exact"
3.0	15.281660036	15.281981407	15.282003300	15.282004826

Runge-Kutta semilinear method				
$x$	$h = 0.1$	$h = 0.05$	$h = 0.025$	"Exact"
3.0	15.282005990	15.282004899	15.282004831	15.282004826

**3.3.15 (p. 126)**

Runge-Kutta method				
$x$	$h = 0.2$	$h = 0.1$	$h = 0.05$	"Exact"
2.0	0.904678156	0.904295772	0.904277759	0.904276722

Runge-Kutta semilinear method				
$x$	$h = 0.2$	$h = 0.1$	$h = 0.05$	"Exact"
2.0	0.904592215	0.904297062	0.904278004	0.904276722

**3.3.16 (p. 126)**

Runge-Kutta method				
$x$	$h = 0.2$	$h = 0.1$	$h = 0.05$	"Exact"
3.0	0.967523147	0.967523152	0.967523153	0.967523153

Runge-Kutta semilinear method				
$x$	$h = 0.2$	$h = 0.1$	$h = 0.05$	"Exact"
3.0	0.967523147	0.967523152	0.967523153	0.967523153

**3.3.17 (p. 126)**

Runge-Kutta method				
$x$	$h = 0.0500$	$h = 0.0250$	$h = 0.0125$	"Exact"
1.50	0.343839158	0.343784814	0.343780796	0.343780513

Runge-Kutta semilinear method				
$x$	$h = 0.0500$	$h = 0.0250$	$h = 0.0125$	"Exact"
1.00	0.000000000	0.000000000	0.000000000	0.000000000
1.05	0.028121022	0.028121010	0.028121010	0.028121010
1.10	0.055393494	0.055393466	0.055393465	0.055393464
1.15	0.082164048	0.082163994	0.082163990	0.082163990
1.20	0.108862698	0.108862597	0.108862591	0.108862590
1.25	0.136058715	0.136058528	0.136058517	0.136058516
1.30	0.164564862	0.164564496	0.164564473	0.164564471
1.35	0.195651074	0.195650271	0.195650219	0.195650216
1.40	0.231542288	0.231540164	0.231540027	0.231540017
1.45	0.276818775	0.276811011	0.276810491	0.276810456
1.50	0.343839124	0.343784811	0.343780796	0.343780513

**3.3.18 (p. 126)**

Runge-Kutta method				
$x$	$h = 0.2$	$h = 0.1$	$h = 0.05$	"Exact"
2.0	0.732633229	0.732638318	0.732638609	0.732638628

Runge-Kutta semilinear method				
$x$	$h = 0.2$	$h = 0.1$	$h = 0.05$	"Exact"
2.0	0.732639212	0.732638663	0.732638630	0.732638628

**3.3.19 (p. 126)**

Runge-Kutta method				
$x$	$h = 0.0500$	$h = 0.0250$	$h = 0.0125$	"Exact"
1.50	2.244025683	2.244024088	2.244023989	2.244023982

Runge-Kutta semilinear method				
$x$	$h = 0.0500$	$h = 0.0250$	$h = 0.0125$	"Exact"
1.50	2.244025081	2.244024051	2.244023987	2.244023982

**3.3.20 (p. 126)**

Runge-Kutta method				
$x$	$h = 0.1$	$h = 0.05$	$h = 0.025$	"Exact"
1.0	0.056426886	0.056416137	0.056415552	0.056415515

Runge-Kutta semilinear method				
$x$	$h = 0.1$	$h = 0.05$	$h = 0.025$	"Exact"
1.0	0.056415185	0.056415495	0.056415514	0.056415515

**3.3.21 (p. 126)**

Runge-Kutta method				
$x$	$h = 0.1$	$h = 0.05$	$h = 0.025$	"Exact"
1.0	54.695901186	54.727111858	54.729426250	54.729594761

Runge-Kutta semilinear method				
$x$	$h = 0.1$	$h = 0.05$	$h = 0.025$	"Exact"
1.0	54.729099966	54.729561720	54.729592658	54.729594761

**3.3.22 (p. 126)**

Runge-Kutta method				
$x$	$h = 0.1$	$h = 0.05$	$h = 0.025$	"Exact"
3.0	1.361384082	1.361383812	1.361383809	1.361383810

Runge-Kutta semilinear method				
$x$	$h = 0.1$	$h = 0.05$	$h = 0.025$	"Exact"
3.0	1.361456502	1.361388196	1.361384079	1.361383810

**3.3.24 (p. 127)**

$x$	$h = .1$	$h = .05$	$h = .025$	Exact
2.00	-1.000000000	-1.000000000	-1.000000000	-1.000000000

**3.3.25 (p. 127)**

$x$	$h = .1$	$h = .05$	$h = .025$	"Exact"
1.00	1.000000000	1.000000000	1.000000000	1.000000000

**3.3.26 (p. 127)**

$x$	$h = .1$	$h = .05$	$h = .025$	Exact
1.50	4.142171279	4.142170553	4.142170508	4.142170505

**3.3.27 (p. 127)**

$x$	$h = .1$	$h = .05$	$h = .025$	Exact
3.0	16.666666988	16.666666687	16.666666668	16.666666667

**Section 4.1 Answers, pp. 138–140**

4.1.1 (p. 138)  $Q = 20e^{-(t \ln 2)/3200}$  g    4.1.2 (p. 138)  $\frac{2 \ln 10}{\ln 2}$  days    4.1.3 (p. 138)  $\tau = 10 \frac{\ln 2}{\ln 4/3}$  minutes



- 4.1.4 (p. 138)  $\tau \frac{\ln(p_0/p_1)}{\ln 2}$  4.1.5 (p. 138)  $\frac{t_p}{t_q} = \frac{\ln p}{\ln q}$  4.1.6 (p. 138)  $k = \frac{1}{t_2 - t_1} \ln \frac{Q_1}{Q_2}$  4.1.7 (p. 138) 20 g
- 4.1.8 (p. 138)  $\frac{50 \ln 2}{3}$  yrs 4.1.9 (p. 138)  $\frac{25}{2} \ln 2\%$
- 4.1.10 (p. 138) (a) =  $20 \ln 3$  yr (b).  $Q_0 = 100000e^{-.5}$  4.1.11 (p. 138) (a)  $Q(t) = 5000 - 4750e^{-t/10}$  (b) 5000 lbs
- 4.1.12 (p. 138)  $\frac{1}{25}$  yrs; 4.1.13 (p. 138)  $V = V_0 e^{t \ln 10/2}$  4 hours
- 4.1.14 (p. 138)  $\frac{1500 \ln \frac{4}{3}}{\ln 2}$  yrs;  $2^{-4/3} Q_0$  4.1.15 (p. 138)  $W(t) = 20 - 19e^{-t/20}$ ;  $\lim_{t \rightarrow \infty} W(t) = 20$  ounces
- 4.1.16 (p. 138)  $S(t) = 10(1 + e^{-t/10})$ ;  $\lim_{t \rightarrow \infty} S(t) = 10$  g 4.1.17 (p. 139) 10 gallons
- 4.1.18 (p. 139)  $V(t) = 15000 + 10000e^{t/20}$  4.1.19 (p. 139)  $W(t) = 4 \times 10^6(t + 1)^2$  dollars  $t$  years from now
- 4.1.20 (p. 139)  $p = \frac{100}{25 - 24e^{-t/2}}$  4.1.21 (p. 139) (a)  $P(t) = 1000e^{.06t} + 50 \frac{e^{.06t} - 1}{e^{.06/52} - 1}$  (b)  $5.64 \times 10^{-4}$
- 4.1.22 (p. 139) (a)  $P' = rP - 12M$  (b)  $P = \frac{12M}{r}(1 - e^{rt}) + P_0 e^{rt}$  (c)  $M \approx \frac{rP_0}{12(1 - e^{-rN})}$   
 (d) For (i) approximate  $M = \$402.25$ , exact  $M = \$402.80$   
 for (ii) approximate  $M = \$1206.05$ , exact  $M = \$1206.93$ .
- 4.1.23 (p. 139) (a)  $T(\alpha) = -\frac{1}{r} \ln(1 - (1 - e^{-rN})/\alpha)$  years  
 $S(\alpha) = \frac{P_0}{(1 - e^{-rN})} [rN + \alpha \ln(1 - (1 - e^{-rN})/\alpha)]$   
 (b)  $T(1.05) = 13.69$  yrs,  $S(1.05) = \$3579.94$   $T(1.10) = 12.61$  yrs,  
 $S(1.10) = \$6476.63$   $T(1.15) = 11.70$  yrs,  $S(1.15) = \$8874.98$ .
- 4.1.24 (p. 140)  $P_0 = \begin{cases} \frac{S_0(1 - e^{(a-r)T})}{r - a} & \text{if } a \neq r, \\ S_0 T & \text{if } a = r. \end{cases}$

Section 4.2 Answers, pp. 148–150

- 4.2.1 (p. 148)  $\approx 15.15^\circ\text{F}$  4.2.2 (p. 148)  $T = -10 + 110e^{-t \ln \frac{11}{9}}$  4.2.3 (p. 148)  $\approx 24.33^\circ\text{F}$
- 4.2.4 (p. 148) (a)  $91.30^\circ\text{F}$  (b) 8.99 minutes after being placed outside (c) never
- 4.2.5 (p. 148) (a) 12:11:32 (b) 12:47:33 4.2.6 (p. 148)  $(85/3)^\circ\text{C}$  4.2.7 (p. 148)  $32^\circ\text{F}$  4.2.8 (p. 148)  $Q(t) = 40(1 - e^{-3t/40})$
- 4.2.9 (p. 148)  $Q(t) = 30 - 20e^{-t/10}$  4.2.10 (p. 148)  $K(t) = .3 - .2e^{-t/20}$  4.2.11 (p. 148)  $Q(50) = 47.5$  (pounds)
- 4.2.12 (p. 148) 50 gallons 4.2.13 (p. 148)  $\min q_2 = q_1/\bar{c}$  4.2.14 (p. 149)  $Q = t + 300 - \frac{234 \times 10^5}{(t + 300)^2}$ ,  $0 \leq t \leq 300$
- 4.2.15 (p. 149) (a)  $Q' + \frac{2}{25}Q = 6 - 2e^{-t/25}$  (b)  $Q = 75 - 50e^{-t/25} - 25e^{-2t/25}$  (c) 75
- 4.2.16 (p. 149) (a)  $T = T_m + (T_0 - T_m)e^{-kt} + \frac{k(S_0 - T_m)}{(k - k_m)}(e^{-k_m t} - e^{-kt})$   
 (b)  $T = T_m + k(S_0 - T_m)te^{-kt} + (T_0 - T_m)e^{-kt}$  (c)  $\lim_{t \rightarrow \infty} T(t) = \lim_{t \rightarrow \infty} S(t) = T_m$
- 4.2.17 (p. 149) (a)  $T' = -k\left(1 + \frac{a}{a_m}\right)T + k\left(T_{m0} + \frac{a}{a_m}T_0\right)$  (b)  $T = \frac{aT_0 + a_m T_{m0}}{a + a_m} + \frac{a_m(T_0 - T_{m0})}{a + a_m}e^{-k(1+a/a_m)t}$ ,  
 $T_m = \frac{aT_0 + a_m T_{m0}}{a + a_m} + \frac{a(T_{m0} - T_0)}{a + a_m}e^{-k(1+a/a_m)t}$ ; (c)  $\lim_{t \rightarrow \infty} T(t) = \lim_{t \rightarrow \infty} T_m(t) = \frac{aT_0 + a_m T_{m0}}{a + a_m}$
- 4.2.18 (p. 150)  $V = \frac{a}{b} \frac{V_0}{V_0 - (V_0 - a/b)e^{-at}}$ ,  $\lim_{t \rightarrow \infty} V(t) = a/b$
- 4.2.19 (p. 150)  $c_1 = c(1 - e^{-rt/W})$ ,  $c_2 = c\left(1 - e^{-rt/W} - \frac{r}{W}te^{-rt/W}\right)$ .

$$4.2.20 \text{ (p. 150) (a) } c_n = c \left( 1 - e^{-rt/W} \sum_{j=0}^{n-1} \frac{1}{j!} \left( \frac{rt}{W} \right)^j \right) \text{ (b) } c \text{ (c) } 0$$

$$4.2.21 \text{ (p. 150) Let } c_\infty = \frac{c_1 W_1 + c_2 W_2}{W_1 + W_2}, \alpha = \frac{c_2 W_2^2 - c_1 W_1^2}{W_1 + W_2}, \text{ and } \beta = \frac{W_1 + W_2}{W_1 W_2}. \text{ Then:}$$

$$\text{(a) } c_1(t) = c_\infty + \frac{\alpha}{W_1} e^{-r\beta t}, c_2(t) = c_\infty - \frac{\alpha}{W_2} e^{-r\beta t}$$

$$\text{(b) } \lim_{t \rightarrow \infty} c_1(t) = \lim_{t \rightarrow \infty} c_2(t) = c_\infty$$

### Section 4.3 Answers, pp. 160–162

$$4.3.1 \text{ (p. 160) } v = -\frac{384}{5} (1 - e^{-5t/12}); -\frac{384}{5} \text{ ft/s } 4.3.2 \text{ (p. 160) } k = 12; v = -16(1 - e^{-2t})$$

$$4.3.3 \text{ (p. 160) } v = 25(1 - e^{-t}); 25 \text{ ft/s } 4.3.4 \text{ (p. 160) } v = 20 - 27e^{-t/40} 4.3.5 \text{ (p. 160) } \approx 17.10 \text{ ft}$$

$$4.3.6 \text{ (p. 160) } v = -\frac{40(13 + 3e^{-4t/5})}{13 - 3e^{-4t/5}}; -40 \text{ ft/s } 4.3.7 \text{ (p. 160) } v = -128(1 - e^{-t/4})$$

$$4.3.9 \text{ (p. 160) } T = \frac{m}{k} \ln \left( 1 + \frac{v_0 k}{mg} \right); y_m = y_0 + \frac{m}{k} \left[ v_0 - \frac{mg}{k} \ln \left( 1 + \frac{v_0 k}{mg} \right) \right]$$

$$4.3.10 \text{ (p. 161) } v = -\frac{64(1 - e^{-t})}{1 + e^{-t}}; -64 \text{ ft/s}$$

$$4.3.11 \text{ (p. 161) } v = \alpha \frac{v_0(1 + e^{-\beta t}) - \alpha(1 - e^{-\beta t})}{\alpha(1 + e^{-\beta t}) - v_0(1 - e^{-\beta t})}; -\alpha, \text{ where } \alpha = \sqrt{\frac{mg}{k}} \text{ and } \beta = 2\sqrt{\frac{kg}{m}}$$

$$4.3.12 \text{ (p. 161) } T = \sqrt{\frac{m}{kg}} \tan^{-1} \left( v_0 \sqrt{\frac{k}{mg}} \right) v = -\sqrt{\frac{mg}{k}}; \frac{1 - e^{-2\sqrt{\frac{kg}{m}}(t-T)}}{1 + e^{-2\sqrt{\frac{kg}{m}}(t-T)}}$$

$$4.3.13 \text{ (p. 161) } s' = mg - \frac{as}{s+1}; a_0 = mg. 4.3.14 \text{ (p. 161) (a) } ms' = mg - f(s)$$

$$4.3.15 \text{ (p. 161) (a) } v' = -9.8 + v^4/81 \text{ (b) } v_T \approx -5.308 \text{ m/s}$$

$$4.3.16 \text{ (p. 161) (a) } v' = -32 + 8\sqrt{|v|}; v_T = -16 \text{ ft/s (b) From Exercise 4.3.14(c), } v_T \text{ is the negative number such that } -32 + 8\sqrt{|v_T|} = 0; \text{ thus, } v_T = -16 \text{ ft/s.}$$

$$4.3.17 \text{ (p. 162) } \approx 6.76 \text{ miles/s } 4.3.18 \text{ (p. 162) } \approx 1.47 \text{ miles/s } 4.3.20 \text{ (p. 162) } \alpha = \frac{gR^2}{(y_m + R)^2}$$

### Section 4.4 Answers, pp. 176–177

$$4.4.1 \text{ (p. 176) } \bar{y} = 0 \text{ is a stable equilibrium; trajectories are } v^2 + \frac{y^4}{4} = c$$

$$4.4.2 \text{ (p. 176) } \bar{y} = 0 \text{ is an unstable equilibrium; trajectories are } v^2 + \frac{2y^3}{3} = c$$

$$4.4.3 \text{ (p. 176) } \bar{y} = 0 \text{ is a stable equilibrium; trajectories are } v^2 + \frac{2|y|^3}{3} = c$$

$$4.4.4 \text{ (p. 176) } \bar{y} = 0 \text{ is a stable equilibrium; trajectories are } v^2 - e^{-y}(y+1) = c$$

$$4.4.5 \text{ (p. 176) equilibria: } 0 \text{ (stable) and } -2, 2 \text{ (unstable); trajectories: } 2v^2 - y^4 + 8y^2 = c; \text{ separatrix: } 2v^2 - y^4 + 8y^2 = 16$$

$$4.4.6 \text{ (p. 176) equilibria: } 0 \text{ (unstable) and } -2, 2 \text{ (stable); trajectories: } 2v^2 + y^4 - 8y^2 = c; \text{ separatrix: } 2v^2 + y^4 - 8y^2 = 0$$

$$4.4.7 \text{ (p. 176) equilibria: } 0, -2, 2 \text{ (stable), } -1, 1 \text{ (unstable); trajectories: } 6v^2 + y^2(2y^4 - 15y^2 + 24) = c; \text{ separatrix: } 6v^2 + y^2(2y^4 - 15y^2 + 24) = 11$$

$$4.4.8 \text{ (p. 176) equilibria: } 0, 2 \text{ (stable) and } -2, 1 \text{ (unstable); trajectories: } 30v^2 + y^2(12y^3 - 15y^2 - 80y + 120) = c; \text{ separatrices: } 30v^2 + y^2(12y^3 - 15y^2 - 80y + 120) = 496 \text{ and}$$

$$30v^2 + y^2(12y^3 - 15y^2 - 80y + 120) = 37$$

4.4.9 (p. 176) No equilibria if  $a < 0$ ; 0 is unstable if  $a = 0$ ;  $\sqrt{a}$  is stable and  $-\sqrt{a}$  is unstable if  $a > 0$ .

\* 4.4.10 (p. 176) 0 is a stable equilibrium if  $a \leq 0$ ;  $-\sqrt{a}$  and  $\sqrt{a}$  are stable and 0 is unstable if  $a > 0$ .

4.4.11 (p. 176) 0 is unstable if  $a \leq 0$ ;  $-\sqrt{a}$  and  $\sqrt{a}$  are unstable and 0 is stable if  $a > 0$ .

4.4.12 (p. 176) 0 is stable if  $a \leq 0$ ; 0 is stable and  $-\sqrt{a}$  and  $\sqrt{a}$  are unstable if  $a \leq 0$ .

4.4.22 (p. 178) An equilibrium solution  $\bar{y}$  of  $y'' + p(y) = 0$  is unstable if there's an  $\epsilon > 0$

such that, for every  $\delta > 0$ , there's a solution of (A) with  $\sqrt{(y(0) - \bar{y})^2 + v^2(0)} < \delta$ , but  $\sqrt{(y(t) - \bar{y})^2 + v^2(t)} \geq \epsilon$  for some  $t > 0$ .

**Section 4.5 Answers, pp. 190–192**

4.5.1 (p. 190)  $y' = -\frac{2xy}{x^2 + 3y^2}$  4.5.2 (p. 190)  $y' = -\frac{y^2}{(xy - 1)}$  4.5.3 (p. 190)  $y' = -\frac{y(x^2 + y^2 - 2x^2 \ln |xy|)}{x(x^2 + y^2 - 2y^2 \ln |xy|)}$ .

4.5.4 (p. 190)  $xy' - y = -\frac{x^{1/2}}{2}$  4.5.5 (p. 190)  $y' + 2xy = 4xe^{x^2}$  4.5.6 (p. 190)  $xy' + y = 4x^3$

4.5.7 (p. 190)  $y' - y = \cos x - \sin x$  4.5.8 (p. 190)  $(1 + x^2)y' - 2xy = (1 - x)^2 e^x$

4.5.10 (p. 190)  $y'g - yg' = f'g - fg'$  4.5.11 (p. 190)  $(x - x_0)y' = y - y_0$  4.5.12 (p. 190)  $y'(y^2 - x^2 + 1) + 2xy = 0$  4.5.13 (p. 190)  $2x(y - 1)y' - y^2 + x^2 + 2y = 0$

4.5.14 (p. 190) (a)  $y = -81 + 18x, (9, 81)$   $y = -1 + 2x, (1, 1)$

(b)  $y = -121 + 22x, (11, 121)$   $y = -1 + 2x, (1, 1)$

(c)  $y = -100 - 20x, (-10, 100)$   $y = -4 - 4x, (-2, 4)$

(d)  $y = -25 - 10x, (-5, 25)$   $y = -1 - 2x, (-1, 1)$

4.5.15 (p. 190) (e)  $y = \frac{5 + 3x}{4}, (-3/5, 4/5)$   $y = -\frac{5 - 4x}{3}, (4/5, -3/5)$

4.5.17 (p. 191) (a)  $y = -\frac{1}{2}(1 + x), (1, -1);$   $y = \frac{5}{2} + \frac{x}{10}, (25, 5)$

(b)  $y = \frac{1}{4}(4 + x), (4, 2)$   $y = -\frac{1}{4}(4 + x), (4, -2);$

(c)  $y = \frac{1}{2}(1 + x), (1, 1)$   $y = \frac{7}{2} + \frac{x}{14}, (49, 7)$

(d)  $y = -\frac{1}{2}(1 + x), (1, -1)$   $y = -\frac{5}{2} - \frac{x}{10}, (25, -5)$

4.5.18 (p. 191)  $y = 2x^2$  4.5.19 (p. 192)  $y = \frac{cx}{\sqrt{|x^2 - 1|}}$  4.5.20 (p. 192)  $y = y_1 + c(x - x_1)$

4.5.21 (p. 192)  $y = -\frac{x^3}{2} - \frac{x}{2}$  4.5.22 (p. 192)  $y = -x \ln |x| + cx$  4.5.23 (p. 192)  $y = \sqrt{2x + 4}$

4.5.24 (p. 192)  $y = \sqrt{x^2 - 3}$  4.5.25 (p. 192)  $y = kx^2$  4.5.26 (p. 192)  $(y - x)^3(y + x) = k$

4.5.27 (p. 192)  $y^2 = -x + k$  4.5.28 (p. 192)  $y^2 = -\frac{1}{2} \ln(1 + 2x^2) + k$

4.5.29 (p. 192)  $y^2 = -2x - \ln(x - 1)^2 + k$  4.5.30 (p. 192)  $y = 1 + \sqrt{\frac{9 - x^2}{2}}$ ; those with  $c > 0$

4.5.33 (p. 192)  $\tan^{-1} \frac{y}{x} - \frac{1}{2} \ln(x^2 + y^2) = k$  4.5.34 (p. 192)  $\frac{1}{2} \ln(x^2 + y^2) + (\tan \alpha) \tan^{-1} \frac{y}{x} = k$

**Section 5.1 Answers, pp. 203–210**

5.1.1 (p. 203) (c)  $y = -2e^{2x} + e^{5x}$  (d)  $y = (5k_0 - k_1)\frac{e^{2x}}{3} + (k_1 - 2k_0)\frac{e^{5x}}{3}$ .

5.1.2 (p. 203) (c)  $y = e^x(3 \cos x - 5 \sin x)$  (d)  $y = e^x(k_0 \cos x + (k_1 - k_0) \sin x)$

5.1.3 (p. 204) (c)  $y = e^x(7 - 3x)$  (d)  $y = e^x(k_0 + (k_1 - k_0)x)$

$$5.1.4 \text{ (p. 204)} \text{ (a) } y = \frac{c_1}{x-1} + \frac{c_2}{x+1} \text{ (b) } y = \frac{2}{x-1} - \frac{3}{x+1}; (-1, 1)$$

$$5.1.5 \text{ (p. 204)} \text{ (a) } e^x \text{ (b) } e^{2x} \cos x \text{ (c) } x^2 + 2x - 2 \text{ (d) } -\frac{5}{6}x^{-5/6} \text{ (e) } -\frac{1}{x^2} \text{ (f) } (x \ln |x|)^2 \text{ (g) } \frac{e^{2x}}{2\sqrt{x}}$$

$$5.1.6 \text{ (p. 204)} \text{ 0 } 5.1.7 \text{ (p. 204)} W(x) = (1-x^2)^{-1} \quad 5.1.8 \text{ (p. 205)} W(x) = \frac{1}{x} \quad 5.1.10 \text{ (p. 205)} y_2 = e^{-x}$$

$$5.1.11 \text{ (p. 205)} y_2 = xe^{3x} \quad 5.1.12 \text{ (p. 205)} y_2 = xe^{ax} \quad 5.1.13 \text{ (p. 205)} y_2 = \frac{1}{x} \quad 5.1.14 \text{ (p. 205)} y_2 = x \ln x$$

$$5.1.15 \text{ (p. 205)} y_2 = x^a \ln x \quad 5.1.16 \text{ (p. 205)} y_2 = x^{1/2}e^{-2x} \quad 5.1.17 \text{ (p. 205)} y_2 = x \quad 5.1.18 \text{ (p. 205)} y_2 = x \sin x$$

$$5.1.19 \text{ (p. 205)} y_2 = x^{1/2} \cos x \quad 5.1.20 \text{ (p. 205)} y_2 = xe^{-x} \quad 5.1.21 \text{ (p. 205)} y_2 = \frac{1}{x^2 - 4}$$

$$5.1.22 \text{ (p. 205)} y_2 = e^{2x}$$

$$5.1.23 \text{ (p. 205)} y_2 = x^2 \quad 5.1.35 \text{ (p. 207)} \text{ (a) } y'' - 2y' + 5y = 0 \text{ (b) } (2x-1)y'' - 4xy' + 4y = 0 \text{ (c) } x^2y'' - xy' + y = 0$$

$$\text{(d) } x^2y'' + xy' + y = 0 \text{ (e) } y'' - y = 0 \text{ (f) } xy'' - y' = 0$$

$$5.1.37 \text{ (p. 207)} \text{ (c) } y = k_0y_1 + k_1y_2 \quad 5.1.38 \text{ (p. 208)} y_1 = 1, y_2 = x - x_0; y = k_0 + k_1(x - x_0)$$

$$5.1.39 \text{ (p. 208)} y_1 = \cosh(x - x_0), y_2 = \sinh(x - x_0); y = k_0 \cosh(x - x_0) + k_1 \sinh(x - x_0)$$

$$5.1.40 \text{ (p. 208)} y_1 = \cos \omega(x - x_0), y_2 = \frac{1}{\omega} \sin \omega(x - x_0); y = k_0 \cos \omega(x - x_0) + \frac{k_1}{\omega} \sin \omega(x - x_0)$$

$$5.1.41 \text{ (p. 208)} y_1 = \frac{1}{1-x^2}, y_2 = \frac{x}{1-x^2}; y = \frac{k_0 + k_1x}{1-x^2}$$

$$5.1.42 \text{ (p. 209)} \text{ (c) } k_0 = k_1 = 0; y = \begin{cases} c_1x^2 + c_2x^3, & x \geq 0, \\ c_1x^2 + c_3x^3, & x < 0 \end{cases}$$

$$\text{(d) } (0, \infty) \text{ if } x_0 > 0, (-\infty, 0) \text{ if } x_0 < 0$$

$$5.1.43 \text{ (p. 209)} \text{ (c) } k_0 = 0, k_1 \text{ arbitrary } y = k_1x + c_2x^2$$

$$5.1.44 \text{ (p. 210)} \text{ (c) } k_0 = k_1 = 0; y = \begin{cases} a_1x^3 + a_2x^4, & x \geq 0, \\ b_1x^3 + b_2x^4, & x < 0 \end{cases}$$

$$\text{(d) } (0, \infty) \text{ if } x_0 > 0, (-\infty, 0) \text{ if } x_0 < 0$$

### Section 5.2 Answers, pp. 217–220

$$5.2.1 \text{ (p. 217)} y = c_1e^{-6x} + c_2e^x \quad 5.2.2 \text{ (p. 217)} y = e^{2x}(c_1 \cos x + c_2 \sin x) \quad 5.2.3 \text{ (p. 217)} y = c_1e^{-7x} + c_2e^{-x}$$

$$5.2.4 \text{ (p. 217)} y = e^{2x}(c_1 + c_2x) \quad 5.2.5 \text{ (p. 217)} y = e^{-x}(c_1 \cos 3x + c_2 \sin 3x)$$

$$5.2.6 \text{ (p. 217)} y = e^{-3x}(c_1 \cos x + c_2 \sin x) \quad 5.2.7 \text{ (p. 217)} y = e^{4x}(c_1 + c_2x) \quad 5.2.8 \text{ (p. 217)} y = c_1 + c_2e^{-x}$$

$$5.2.9 \text{ (p. 217)} y = e^x(c_1 \cos \sqrt{2}x + c_2 \sin \sqrt{2}x) \quad 5.2.10 \text{ (p. 217)} y = e^{-3x}(c_1 \cos 2x + c_2 \sin 2x)$$

$$5.2.11 \text{ (p. 217)} y = e^{-x/2} \left( c_1 \cos \frac{3x}{2} + c_2 \sin \frac{3x}{2} \right) \quad 5.2.12 \text{ (p. 217)} y = c_1e^{-x/5} + c_2e^{x/2}$$

$$5.2.13 \text{ (p. 218)} y = e^{-7x}(2 \cos x - 3 \sin x) \quad 5.2.14 \text{ (p. 218)} y = 4e^{x/2} + 6e^{-x/3} \quad 5.2.15 \text{ (p. 218)} y = 3e^{x/3} - 4e^{-x/2}$$

$$5.2.16 \text{ (p. 218)} y = \frac{e^{-x/2}}{3} + \frac{3e^{3x/2}}{4} \quad 5.2.17 \text{ (p. 218)} y = e^{3x/2}(3 - 2x) \quad 5.2.18 \text{ (p. 218)} y = 3e^{-4x} - 4e^{-3x}$$

$$5.2.19 \text{ (p. 218)} y = 2xe^{3x} \quad 5.2.20 \text{ (p. 218)} y = e^{x/6}(3+2x) \quad 5.2.21 \text{ (p. 218)} y = e^{-2x} \left( 3 \cos \sqrt{6}x + \frac{2\sqrt{6}}{3} \sin \sqrt{6}x \right)$$

$$5.2.23 \text{ (p. 218)} y = 2e^{-(x-1)} - 3e^{-2(x-1)} \quad 5.2.24 \text{ (p. 219)} y = \frac{1}{3}e^{-(x-2)} - \frac{2}{3}e^{7(x-2)}$$

$$5.2.25 \text{ (p. 219)} y = e^{7(x-1)}(2 - 3(x-1)) \quad 5.2.26 \text{ (p. 219)} y = e^{-(x-2)/3}(2 - 4(x-2))$$

$$5.2.27 \text{ (p. 219)} y = 2 \cos \frac{2}{3} \left( x - \frac{\pi}{4} \right) - 3 \sin \frac{2}{3} \left( x - \frac{\pi}{4} \right) \quad 5.2.28 \text{ (p. 219)} y = 2 \cos \sqrt{3} \left( x - \frac{\pi}{3} \right) - \frac{1}{\sqrt{3}} \sin \sqrt{3} \left( x - \frac{\pi}{3} \right)$$

$$5.2.30 \text{ (p. 219)} y = \frac{k_0}{r_2 - r_1} (r_2 e^{r_1(x-x_0)} - r_1 e^{r_2(x-x_0)}) + \frac{k_1}{r_2 - r_1} (e^{r_2(x-x_0)} - e^{r_1(x-x_0)})$$

$$5.2.31 \text{ (p. 219)} y = e^{r_1(x-x_0)} [k_0 + (k_1 - r_1 k_0)(x - x_0)]$$

5.2.32 (p. 219)  $y = e^{\lambda(x-x_0)} \left[ k_0 \cos \omega(x-x_0) + \left( \frac{k_1 - \lambda k_0}{\omega} \right) \sin \omega(x-x_0) \right]$

Section 5.3 Answers, pp. 227–229

5.3.1 (p. 227)  $y_p = -1 + 2x + 3x^2; y = -1 + 2x + 3x^2 + c_1 e^{-6x} + c_2 e^x$

5.3.2 (p. 227)  $y_p = 1 + x; y = 1 + x + e^{2x}(c_1 \cos x + c_2 \sin x)$

5.3.3 (p. 227)  $y_p = -x + x^3; y = -x + x^3 + c_1 e^{-7x} + c_2 e^{-x}$

5.3.4 (p. 227)  $y_p = 1 - x^2; y = 1 - x^2 + e^{2x}(c_1 + c_2 x)$

5.3.5 (p. 227)  $y_p = 2x + x^3; y = 2x + x^3 + e^{-x}(c_1 \cos 3x + c_2 \sin 3x);$   
 $y = 2x + x^3 + e^{-x}(2 \cos 3x + 3 \sin 3x)$

5.3.6 (p. 227)  $y_p = 1 + 2x; y = 1 + 2x + e^{-3x}(c_1 \cos x + c_2 \sin x); y = 1 + 2x + e^{-3x}(\cos x - \sin x)$

5.3.8 (p. 227)  $y_p = \frac{2}{x}$  5.3.9 (p. 227)  $y_p = 4x^{1/2}$  5.3.10 (p. 227)  $y_p = \frac{x^3}{2}$  5.3.11 (p. 227)  $y_p = \frac{1}{x^3}$

5.3.12 (p. 227)  $y_p = 9x^{1/3}$  5.3.13 (p. 227)  $y_p = \frac{2x^4}{13}$  5.3.16 (p. 228)  $y_p = \frac{e^{3x}}{3}; y = \frac{e^{3x}}{3} + c_1 e^{-6x} + c_2 e^x$

5.3.17 (p. 228)  $y_p = e^{2x}; y = e^{2x}(1 + c_1 \cos x + c_2 \sin x)$

5.3.18 (p. 228)  $y = -2e^{-2x}; y = -2e^{-2x} + c_1 e^{-7x} + c_2 e^{-x}; y = -2e^{-2x} - e^{-7x} + e^{-x}$

5.3.19 (p. 228)  $y_p = e^x; y = e^x + e^{2x}(c_1 + c_2 x); y = e^x + e^{2x}(1 - 3x)$

5.3.20 (p. 228)  $y_p = \frac{4}{45}e^{x/2}; y = \frac{4}{45}e^{x/2} + e^{-x}(c_1 \cos 3x + c_2 \sin 3x)$

5.3.21 (p. 228)  $y_p = e^{-3x}; y = e^{-3x}(1 + c_1 \cos x + c_2 \sin x)$

5.3.24 (p. 228)  $y_p = \cos x - \sin x; y = \cos x - \sin x + e^{4x}(c_1 + c_2 x)$

5.3.25 (p. 228)  $y_p = \cos 2x - 2 \sin 2x; y = \cos 2x - 2 \sin 2x + c_1 + c_2 e^{-x}$

5.3.26 (p. 228)  $y_p = \cos 3x; y = \cos 3x + e^x(c_1 \cos \sqrt{2}x + c_2 \sin \sqrt{2}x)$

5.3.27 (p. 228)  $y_p = \cos x + \sin x; y = \cos x + \sin x + e^{-3x}(c_1 \cos 2x + c_2 \sin 2x)$

5.3.28 (p. 228)  $y_p = -2 \cos 2x + \sin 2x; y = -2 \cos 2x + \sin 2x + c_1 e^{-4x} + c_2 e^{-3x}$   
 $y = -2 \cos 2x + \sin 2x + 2e^{-4x} - 3e^{-3x}$

5.3.29 (p. 228)  $y_p = \cos 3x - \sin 3x; y = \cos 3x - \sin 3x + e^{3x}(c_1 + c_2 x)$   
 $y = \cos 3x - \sin 3x + e^{3x}(1 + 2x)$

5.3.30 (p. 228)  $y = \frac{1}{\omega_0^2 - \omega^2}(M \cos \omega x + N \sin \omega x) + c_1 \cos \omega_0 x + c_2 \sin \omega_0 x$

5.3.33 (p. 229)  $y_p = -1 + 2x + 3x^2 + \frac{e^{3x}}{3}; y = -1 + 2x + 3x^2 + \frac{e^{3x}}{3} + c_1 e^{-6x} + c_2 e^x$

5.3.34 (p. 229)  $y_p = 1 + x + e^{2x}; y = 1 + x + e^{2x}(1 + c_1 \cos x + c_2 \sin x)$

5.3.35 (p. 229)  $y_p = -x + x^3 - 2e^{-2x}; y = -x + x^3 - 2e^{-2x} + c_1 e^{-7x} + c_2 e^{-x}$

5.3.36 (p. 229)  $y_p = 1 - x^2 + e^x; y = 1 - x^2 + e^x + e^{2x}(c_1 + c_2 x)$

5.3.37 (p. 229)  $y_p = 2x + x^3 + \frac{4}{45}e^{x/2}; y = 2x + x^3 + \frac{4}{45}e^{x/2} + e^{-x}(c_1 \cos 3x + c_2 \sin 3x)$

5.3.38 (p. 229)  $y_p = 1 + 2x + e^{-3x}; y = 1 + 2x + e^{-3x}(1 + c_1 \cos x + c_2 \sin x)$

Section 5.4 Answers, pp. 235–238

5.4.1 (p. 235)  $y_p = e^{3x} \left( -\frac{1}{4} + \frac{x}{2} \right)$  5.4.2 (p. 235)  $y_p = e^{-3x} \left( 1 - \frac{x}{4} \right)$  5.4.3 (p. 235)  $y_p = e^x \left( 2 - \frac{3x}{4} \right)$

5.4.4 (p. 235)  $y_p = e^{2x}(1 - 3x + x^2)$  5.4.5 (p. 235)  $y_p = e^{-x}(1 + x^2)$  5.4.6 (p. 235)  $y_p = e^x(-2 + x + 2x^2)$

5.4.7 (p. 235)  $y_p = x e^{-x} \left( \frac{1}{6} + \frac{x}{2} \right)$  5.4.8 (p. 235)  $y_p = x e^x(1 + 2x)$  5.4.9 (p. 235)  $y_p = x e^{3x} \left( -1 + \frac{x}{2} \right)$

5.4.10 (p. 235)  $y_p = x e^{2x}(-2 + x)$  5.4.11 (p. 235)  $y_p = x^2 e^{-x} \left( 1 + \frac{x}{2} \right)$  5.4.12 (p. 235)  $y_p = x^2 e^x \left( \frac{1}{2} - x \right)$

5.4.13 (p. 235)  $y_p = \frac{x^2 e^{2x}}{2}(1 - x + x^2)$  5.4.14 (p. 235)  $y_p = \frac{x^2 e^{-x/3}}{27}(3 - 2x + x^2)$

- 5.4.15 (p. 235)  $y = \frac{e^{3x}}{4}(-1 + 2x) + c_1e^x + c_2e^{2x}$  5.4.16 (p. 235)  $y = e^x(1 - 2x) + c_1e^{2x} + c_2e^{4x}$   
 5.4.17 (p. 235)  $y = \frac{e^{2x}}{5}(1 - x) + e^{-3x}(c_1 + c_2x)$  5.4.18 (p. 235)  $y = xe^x(1 - 2x) + c_1e^x + c_2e^{-3x}$   
 5.4.19 (p. 235)  $y = e^x[x^2(1 - 2x) + c_1 + c_2x]$  5.4.20 (p. 236)  $y = -e^{2x}(1 + x) + 2e^{-x} - e^{5x}$   
 5.4.21 (p. 236)  $y = xe^{2x} + 3e^x - e^{-4x}$  5.4.22 (p. 236)  $y = e^{-x}(2 + x - 2x^2) - e^{-3x}$   
 5.4.23 (p. 236)  $y = e^{-2x}(3 - x) - 2e^{5x}$  5.4.24 (p. 236)  $y_p = -\frac{e^x}{3}(1 - x) + e^{-x}(3 + 2x)$   
 5.4.25 (p. 236)  $y_p = e^x(3 + 7x) + xe^{3x}$  5.4.26 (p. 236)  $y_p = x^3e^{4x} + 1 + 2x + x^2$   
 5.4.27 (p. 236)  $y_p = xe^{2x}(1 - 2x) + xe^x$  5.4.28 (p. 236)  $y_p = e^x(1 + x) + x^2e^{-x}$   
 5.4.29 (p. 236)  $y_p = x^2e^{-x} + e^{3x}(1 - x^2)$  5.4.31 (p. 237)  $y_p = 2e^{2x}$  5.4.32 (p. 237)  $y_p = 5xe^{4x}$   
 5.4.33 (p. 237)  $y_p = x^2e^{4x}$  5.4.34 (p. 237)  $y_p = -\frac{e^{3x}}{4}(1 + 2x - 2x^2)$  5.4.35 (p. 237)  $y_p = xe^{3x}(4 - x + 2x^2)$   
 5.4.36 (p. 237)  $y_p = x^2e^{-x/2}(-1 + 2x + 3x^2)$   
 5.4.37 (p. 237) (a)  $y = e^{-x}\left(\frac{4}{3}x^{3/2} + c_1x + c_2\right)$  (b)  $y = e^{-3x}\left[\frac{x^2}{4}(2\ln x - 3) + c_1x + c_2\right]$   
 (c)  $y = e^{2x}[(x + 1)\ln|x + 1| + c_1x + c_2]$  (d)  $y = e^{-x/2}\left(x\ln|x| + \frac{x^3}{6} + c_1x + c_2\right)$   
 5.4.39 (p. 238) (a)  $e^x(3 + x) + c$  (b)  $-e^{-x}(1 + x)^2 + c$  (c)  $-\frac{e^{-2x}}{8}(3 + 6x + 6x^2 + 4x^3) + c$   
 (d)  $e^x(1 + x^2) + c$  (e)  $e^{3x}(-6 + 4x + 9x^2) + c$  (f)  $-e^{-x}(1 - 2x^3 + 3x^4) + c$   
 5.4.40 (p. 238)  $\frac{(-1)^k k! e^{\alpha x}}{\alpha^{k+1}} \sum_{r=0}^k \frac{(-\alpha x)^r}{r!} + c$

## Section 5.5 Answers, pp. 244–248

- 5.5.1 (p. 244)  $y_p = \cos x + 2\sin x$  5.5.2 (p. 244)  $y_p = \cos x + (2 - 2x)\sin x$   
 5.5.3 (p. 244)  $y_p = e^x(-2\cos x + 3\sin x)$   
 5.5.4 (p. 244)  $y_p = \frac{e^{2x}}{2}(\cos 2x - \sin 2x)$  5.5.5 (p. 244)  $y_p = -e^x(x\cos x - \sin x)$   
 5.5.6 (p. 244)  $y_p = e^{-2x}(1 - 2x)(\cos 3x - \sin 3x)$  5.5.7 (p. 245)  $y_p = x(\cos 2x - 3\sin 2x)$   
 5.5.8 (p. 245)  $y_p = -x[(2 - x)\cos x + (3 - 2x)\sin x]$  5.5.9 (p. 245)  $y_p = x\left[x\cos\left(\frac{x}{2}\right) - 3\sin\left(\frac{x}{2}\right)\right]$   
 5.5.10 (p. 245)  $y_p = xe^{-x}(3\cos x + 4\sin x)$  5.5.11 (p. 245)  $y_p = xe^x[(-1 + x)\cos 2x + (1 + x)\sin 2x]$   
 5.5.12 (p. 245)  $y_p = -(14 - 10x)\cos x - (2 + 8x - 4x^2)\sin x$   
 5.5.13 (p. 245)  $y_p = (1 + 2x + x^2)\cos x + (1 + 3x^2)\sin x$  5.5.14 (p. 245)  $y_p = \frac{x^2}{2}(\cos 2x - \sin 2x)$   
 5.5.15 (p. 245)  $y_p = e^x(x^2\cos x + 2\sin x)$  5.5.16 (p. 245)  $y_p = e^x(1 - x^2)(\cos x + \sin x)$   
 5.5.17 (p. 245)  $y_p = e^x(x^2 - x^3)(\cos x + \sin x)$  5.5.18 (p. 245)  $y_p = e^{-x}[(1 + 2x)\cos x - (1 - 3x)\sin x]$   
 5.5.19 (p. 245)  $y_p = x(2\cos 3x - \sin 3x)$  5.5.20 (p. 245)  $y_p = -x^3\cos x + (x + 2x^2)\sin x$   
 5.5.21 (p. 245)  $y_p = -e^{-x}[(x + x^2)\cos x - (1 + 2x)\sin x]$   
 5.5.22 (p. 245)  $y = e^x(2\cos x + 3\sin x) + 3e^x - e^{6x}$  5.5.23 (p. 245)  $y = e^x[(1 + 2x)\cos x + (1 - 3x)\sin x]$   
 5.5.24 (p. 245)  $y = e^x(\cos x - 2\sin x) + e^{-3x}(\cos x + \sin x)$  5.5.25 (p. 245)  $y = e^{3x}[(2 + 2x)\cos x - (1 + 3x)\sin x]$   
 5.5.26 (p. 245)  $y = e^{3x}[(2 + 3x)\cos x + (4 - x)\sin x] + 3e^x - 5e^{2x}$  5.5.27 (p. 245)  $y_p = xe^{3x} - \frac{e^x}{5}(\cos x - 2\sin x)$   
 5.5.28 (p. 245)  $y_p = x(\cos x + 2\sin x) - \frac{e^x}{2}(1 - x) + \frac{e^{-x}}{2}$   
 5.5.29 (p. 245)  $y_p = -\frac{xe^x}{2}(2 + x) + 2xe^{2x} + \frac{1}{10}(3\cos x + \sin x)$

- 5.5.30 (p. 245)  $y_p = xe^x(\cos x + x \sin x) + \frac{e^{-x}}{25}(4 + 5x) + 1 + x + \frac{x^2}{2}$
- 5.5.31 (p. 245)  $y_p = \frac{x^2 e^{2x}}{6}(3 + x) - e^{2x}(\cos x - \sin x) + 3e^{3x} + \frac{1}{4}(2 + x)$
- 5.5.32 (p. 245)  $y = (1 - 2x + 3x^2)e^{2x} + 4 \cos x + 3 \sin x$  5.5.33 (p. 245)  $y = xe^{-2x} \cos x + 3 \cos 2x$
- 5.5.34 (p. 245)  $y = -\frac{3}{8} \cos 2x + \frac{1}{4} \sin 2x + e^{-x} - \frac{13}{8}e^{-2x} - \frac{3}{4}xe^{-2x}$
- 5.5.40 (p. 248) (a)  $2x \cos x - (2 - x^2) \sin x + c$  (b)  $-\frac{e^x}{2} [(1 - x^2) \cos x - (1 - x)^2 \sin x] + c$
- (c)  $-\frac{e^{-x}}{25} [(4 + 10x) \cos 2x - (3 - 5x) \sin 2x] + c$
- (d)  $-\frac{e^{-x}}{2} [(1 + x)^2 \cos x - (1 - x^2) \sin x] + c$
- (e)  $-\frac{e^x}{2} [x(3 - 3x + x^2) \cos x - (3 - 3x + x^3) \sin x] + c$
- (f)  $-e^x [(1 - 2x) \cos x + (1 + x) \sin x] + c$  (g)  $e^{-x} [x \cos x + x(1 + x) \sin x] + c$

Section 5.6 Answers, pp. 253–255

- 5.6.1 (p. 253)  $y = 1 - 2x + c_1 e^{-x} + c_2 x e^x$ ;  $\{e^{-x}, x e^x\}$  5.6.2 (p. 253)  $y = \frac{4}{3x^2} + c_1 x + \frac{c_2}{x}$ ;  $\{x, 1/x\}$
- 5.6.3 (p. 253)  $y = \frac{x(\ln|x|)^2}{2} + c_1 x + c_2 x \ln|x|$ ;  $\{x, x \ln|x|\}$
- 5.6.4 (p. 253)  $y = (e^{2x} + e^x) \ln(1 + e^{-x}) + c_1 e^{2x} + c_2 e^x$ ;  $\{e^{2x}, e^x\}$
- 5.6.5 (p. 253)  $y = e^x \left( \frac{4}{5} x^{7/2} + c_1 + c_2 x \right)$ ;  $\{e^x, x e^x\}$
- 5.6.6 (p. 253)  $y = e^x (2x^{3/2} + x^{1/2} \ln x + c_1 x^{1/2} + c_2 x^{-1/2})$ ;  $\{x^{1/2} e^x, x^{-1/2} e^{-x}\}$
- 5.6.7 (p. 253)  $y = e^x (x \sin x + \cos x \ln|\cos x| + c_1 \cos x + c_2 \sin x)$ ;  $\{e^x \cos x, e^x \sin x\}$
- 5.6.8 (p. 253)  $y = e^{-x^2} (2e^{-2x} + c_1 + c_2 x)$ ;  $\{e^{-x^2}, x e^{-x^2}\}$
- 5.6.9 (p. 253)  $y = 2x + 1 + c_1 x^2 + \frac{c_2}{x^2}$ ;  $\{x^2, 1/x^2\}$
- 5.6.10 (p. 253)  $y = \frac{x e^{2x}}{9} + x e^{-x} (c_1 + c_2 x)$ ;  $\{x e^{-x}, x^2 e^{-x}\}$
- 5.6.11 (p. 253)  $y = x e^x \left( \frac{x}{3} + c_1 + \frac{c_2}{x^2} \right)$ ;  $\{x e^x, e^x/x\}$
- 5.6.12 (p. 253)  $y = -\frac{(2x - 1)^2 e^x}{8} + c_1 e^x + c_2 x e^{-x}$ ;  $\{e^x, x e^{-x}\}$
- 5.6.13 (p. 253)  $y = x^4 + c_1 x^2 + c_2 x^2 \ln|x|$ ;  $\{x^2, x^2 \ln|x|\}$
- 5.6.14 (p. 253)  $y = e^{-x} (x^{3/2} + c_1 + c_2 x^{1/2})$ ;  $\{e^{-x}, x^{1/2} e^{-x}\}$
- 5.6.15 (p. 253)  $y = e^x (x + c_1 + c_2 x^2)$ ;  $\{e^x, x^2 e^x\}$  5.6.16 (p. 253)  $y = x^{1/2} \left( \frac{e^{2x}}{2} + c_1 + c_2 e^x \right)$ ;  $\{x^{1/2}, x^{1/2} e^x\}$
- 5.6.17 (p. 253)  $y = -2x^2 \ln x + c_1 x^2 + c_2 x^4$ ;  $\{x^2, x^4\}$  5.6.18 (p. 253)  $\{e^x, e^x/x\}$  5.6.19 (p. 253)  $\{x^2, x^3\}$
- 5.6.20 (p. 253)  $\{\ln|x|, x \ln|x|\}$  5.6.21 (p. 253)  $\{\sin \sqrt{x}, \cos \sqrt{x}\}$  5.6.22 (p. 253)  $\{e^x, x^3 e^x\}$  5.6.23 (p. 253)  $\{x^a, x^a \ln x\}$
- 5.6.24 (p. 253)  $\{x \sin x, x \cos x\}$  5.6.25 (p. 253)  $\{e^{2x}, x^2 e^{2x}\}$  5.6.26 (p. 253)  $\{x^{1/2}, x^{1/2} \cos x\}$
- 5.6.27 (p. 253)  $\{x^{1/2} e^{2x}, x^{1/2} e^{-2x}\}$  5.6.28 (p. 253)  $\{1/x, e^{2x}\}$  5.6.29 (p. 253)  $\{e^x, x^2\}$  5.6.30 (p. 253)  $\{e^{2x}, x^2 e^{2x}\}$  5.6.31 (p. 253)  $y = x^4 + 6x^2 - 8x^2 \ln|x|$
- 5.6.32 (p. 253)  $y = 2e^{2x} - x e^{-x}$  5.6.33 (p. 254)  $y = \frac{(x + 1)}{4} [-e^x(3 - 2x) + 7e^{-x}]$
- 5.6.34 (p. 254)  $y = \frac{x^2}{4} + x$  5.6.35 (p. 254)  $y = \frac{(x + 2)^2}{6(x - 2)} + \frac{2x}{x^2 - 4}$

$$5.6.38 \text{ (p. 254) (a) } y = \frac{-kc_1 \sin kx + kc_2 \cos kx}{c_1 \cos kx + c_2 \sin kx} \quad \text{(b) } y = \frac{c_1 + 2c_2 e^x}{c_1 + c_2 e^x}$$

$$\text{(c) } y = \frac{-6c_1 + c_2 e^{7x}}{c_1 + c_2 e^{7x}} \quad \text{(d) } y = -\frac{7c_1 + c_2 e^{6x}}{c_1 + c_2 e^{6x}}$$

$$\text{(e) } y = -\frac{(7c_1 - c_2) \cos x + (c_1 + 7c_2) \sin x}{c_1 \cos x + c_2 \sin x}$$

$$\text{(f) } y = \frac{-2c_1 + 3c_2 e^{5x/6}}{6(c_1 + c_2 e^{5x/6})} \quad \text{(g) } y = \frac{c_1 + c_2(x+6)}{6(c_1 + c_2 x)}$$

$$5.6.39 \text{ (p. 254) (a) } y = \frac{c_1 + c_2 e^x(1+x)}{x(c_1 + c_2 e^x)} \quad \text{(b) } y = \frac{-2c_1 x + c_2(1-2x^2)}{c_1 + c_2 x}$$

$$\text{(c) } y = \frac{-c_1 + c_2 e^{2x}(x+1)}{c_1 + c_2 x e^{2x}} \quad \text{(d) } y = \frac{2c_1 + c_2 e^{-3x}(1-x)}{c_1 + c_2 x e^{-3x}}$$

$$\text{(e) } y = \frac{(2c_2 x - c_1) \cos x - (2c_1 x + c_2) \sin x}{2x(c_1 \cos x + c_2 \sin x)} \quad \text{(f) } y = \frac{c_1 + 7c_2 x^6}{x(c_1 + c_2 x^6)}$$

## Section 5.7 Answers, pp. 262–264

$$5.7.1 \text{ (p. 262) } y_p = \frac{-\cos 3x \ln |\sec 3x + \tan 3x|}{9} \quad 5.7.2 \text{ (p. 262) } y_p = -\frac{\sin 2x \ln |\cos 2x|}{4} + \frac{x \cos 2x}{2}$$

$$5.7.3 \text{ (p. 262) } y_p = 4e^x(1+e^x) \ln(1+e^{-x}) \quad 5.7.4 \text{ (p. 262) } y_p = 3e^x(\cos x \ln |\cos x| + x \sin x)$$

$$5.7.5 \text{ (p. 262) } y_p = \frac{8}{5} x^{7/2} e^x \quad 5.7.6 \text{ (p. 262) } y_p = e^x \ln(1 - e^{-2x}) - e^{-x} \ln(e^{2x} - 1) \quad 5.7.7 \text{ (p. 263) } y_p = \frac{2(x^2 - 3)}{3}$$

$$5.7.8 \text{ (p. 263) } y_p = \frac{e^{2x}}{x} \quad 5.7.9 \text{ (p. 263) } y_p = x^{1/2} e^x \ln x \quad 5.7.10 \text{ (p. 263) } y_p = e^{-x(x+2)}$$

$$5.7.11 \text{ (p. 263) } y_p = -4x^{5/2} \quad 5.7.12 \text{ (p. 263) } y_p = -2x^2 \sin x - 2x \cos x \quad 5.7.13 \text{ (p. 263) } y_p = -\frac{x e^{-x}(x+1)}{2}$$

$$5.7.14 \text{ (p. 263) } y_p = -\frac{\sqrt{x} \cos \sqrt{x}}{2} \quad 5.7.15 \text{ (p. 263) } y_p = \frac{3x^4 e^x}{2} \quad 5.7.16 \text{ (p. 263) } y_p = x^{\alpha+1}$$

$$5.7.17 \text{ (p. 263) } y_p = \frac{x^2 \sin x}{2} \quad 5.7.18 \text{ (p. 263) } y_p = -2x^2 \quad 5.7.19 \text{ (p. 263) } y_p = -e^{-x} \sin x$$

$$5.7.20 \text{ (p. 263) } y_p = -\frac{\sqrt{x}}{2} \quad 5.7.21 \text{ (p. 263) } y_p = \frac{x^{3/2}}{4} \quad 5.7.22 \text{ (p. 263) } y_p = -3x^2$$

$$5.7.23 \text{ (p. 263) } y_p = \frac{x^3 e^x}{2} \quad 5.7.24 \text{ (p. 263) } y_p = -\frac{4x^{3/2}}{15} \quad 5.7.25 \text{ (p. 263) } y_p = x^3 e^x \quad 5.7.26 \text{ (p. 263) } y_p = x e^x$$

$$5.7.27 \text{ (p. 263) } y_p = x^2 \quad 5.7.28 \text{ (p. 263) } y_p = x e^x(x-2) \quad 5.7.29 \text{ (p. 263) } y_p = \sqrt{x} e^x(x-1)/4$$

$$5.7.30 \text{ (p. 263) } y = \frac{e^{2x}(3x^2 - 2x + 6)}{6} + \frac{x e^{-x}}{3} \quad 5.7.31 \text{ (p. 263) } y = (x-1)^2 \ln(1-x) + 2x^2 - 5x + 3$$

$$5.7.32 \text{ (p. 263) } y = (x^2 - 1)e^x - 5(x-1) \quad 5.7.33 \text{ (p. 264) } y = \frac{x(x^2 + 6)}{3(x^2 - 1)} \quad 5.7.34 \text{ (p. 264) } y = -\frac{x^2}{2} + x + \frac{1}{2x^2}$$

$$5.7.35 \text{ (p. 264) } y = \frac{x^2(4x+9)}{6(x+1)}$$

$$5.7.38 \text{ (p. 264) (a) } y = k_0 \cosh x + k_1 \sinh x + \int_0^x \sinh(x-t)f(t) dt$$

$$\text{(b) } y' = k_0 \sinh x + k_1 \cosh x + \int_0^x \cosh(x-t)f(t) dt$$

$$5.7.39 \text{ (p. 264) (a) } y(x) = k_0 \cos x + k_1 \sin x + \int_0^x \sin(x-t)f(t) dt$$

$$\text{(b) } y'(x) = -k_0 \sin x + k_1 \cos x + \int_0^x \cos(x-t)f(t) dt$$



**Section 6.1 Answers, pp. 277–278**

**6.1.1 (p. 277)**  $y = 3 \cos 4\sqrt{6}t - \frac{1}{2\sqrt{6}} \sin 4\sqrt{6}t$  ft    **6.1.2 (p. 277)**  $y = -\frac{1}{4} \cos 8\sqrt{5}t - \frac{1}{4\sqrt{5}} \sin 8\sqrt{5}t$  ft

**6.1.3 (p. 277)**  $y = 1.5 \cos 14\sqrt{10}t$  cm

**6.1.4 (p. 277)**  $y = \frac{1}{4} \cos 8t - \frac{1}{16} \sin 8t$  ft;  $R = \frac{\sqrt{17}}{16}$  ft;  $\omega_0 = 8$  rad/s;  $T = \pi/4$  s;  
 $\phi \approx -.245$  rad  $\approx -14.04^\circ$ ;

**6.1.5 (p. 277)**  $y = 10 \cos 14t + \frac{25}{14} \sin 14t$  cm;  $R = \frac{5}{14} \sqrt{809}$  cm;  $\omega_0 = 14$  rad/s;  $T = \pi/7$  s;  
 $\phi \approx .177$  rad  $\approx 10.12^\circ$

**6.1.6 (p. 277)**  $y = -\frac{1}{4} \cos \sqrt{70}t + \frac{2}{\sqrt{70}} \sin \sqrt{70}t$  m;  $R = \frac{1}{4} \sqrt{\frac{67}{35}}$  m  $\omega_0 = \sqrt{70}$  rad/s;  
 $T = 2\pi/\sqrt{70}$  s;  $\phi \approx 2.38$  rad  $\approx 136.28^\circ$

**6.1.7 (p. 277)**  $y = \frac{2}{3} \cos 16t - \frac{1}{4} \sin 16t$  ft    **6.1.8 (p. 278)**  $y = \frac{1}{2} \cos 8t - \frac{3}{8} \sin 8t$  ft    **6.1.9 (p. 278)** .72 m

**6.1.10 (p. 278)**  $y = \frac{1}{3} \sin t + \frac{1}{2} \cos 2t + \frac{5}{6} \sin 2t$  ft    **6.1.11 (p. 278)**  $y = \frac{16}{5} \left( 4 \sin \frac{t}{4} - \sin t \right)$

**6.1.12 (p. 278)**  $y = -\frac{1}{16} \sin 8t + \frac{1}{3} \cos 4\sqrt{2}t - \frac{1}{8\sqrt{2}} \sin 4\sqrt{2}t$

**6.1.13 (p. 278)**  $y = -t \cos 8t - \frac{1}{6} \cos 8t + \frac{1}{8} \sin 8t$  ft    **6.1.14 (p. 278)**  $T = 4\sqrt{2}$  s

**6.1.15 (p. 278)**  $\omega = 8$  rad/s  $y = -\frac{t}{16}(-\cos 8t + 2 \sin 8t) + \frac{1}{128} \sin 8t$  ft

**6.1.16 (p. 278)**  $\omega = 4\sqrt{6}$  rad/s;  $y = -\frac{t}{\sqrt{6}} \left[ \frac{8}{3} \cos 4\sqrt{6}t + 4 \sin 4\sqrt{6}t \right] + \frac{1}{9} \sin 4\sqrt{6}t$  ft

**6.1.17 (p. 278)**  $y = \frac{t}{2} \cos 2t - \frac{t}{4} \sin 2t + 3 \cos 2t + 2 \sin 2t$  m

**6.1.18 (p. 278)**  $y = y_0 \cos \omega_0 t + \frac{v_0}{\omega_0} \sin \omega_0 t$ ;  $R = \frac{1}{\omega_0} \sqrt{(\omega_0 y_0)^2 + (v_0)^2}$ ;  
 $\cos \phi = \frac{y_0 \omega_0}{\sqrt{(\omega_0 y_0)^2 + (v_0)^2}}$ ;  $\sin \phi = \frac{v_0}{\sqrt{(\omega_0 y_0)^2 + (v_0)^2}}$

**6.1.19 (p. 278)** The object with the longer period weighs four times as much as the other.

**6.1.20 (p. 278)**  $T_2 = \sqrt{2}T_1$ , where  $T_1$  is the period of the smaller object.

**6.1.21 (p. 278)**  $k_1 = 9k_2$ , where  $k_1$  is the spring constant of the system with the shorter period.

**Section 6.2 Answers, pp. 287–289**

**6.2.1 (p. 287)**  $y = \frac{e^{-2t}}{2} (3 \cos 2t - \sin 2t)$  ft;  $\sqrt{\frac{5}{2}} e^{-2t}$  ft

**6.2.2 (p. 287)**  $y = -e^{-t} \left( 3 \cos 3t + \frac{1}{3} \sin 3t \right)$  ft  $\frac{\sqrt{82}}{3} e^{-t}$  ft

**6.2.3 (p. 287)**  $y = e^{-16t} \left( \frac{1}{4} + 10t \right)$  ft    **6.2.4 (p. 287)**  $y = -\frac{e^{-3t}}{4} (5 \cos t + 63 \sin t)$  ft

**6.2.5 (p. 287)**  $0 \leq c < 8$  lb-sec/ft    **6.2.6 (p. 287)**  $y = \frac{1}{2} e^{-3t} \left( \cos \sqrt{91}t + \frac{11}{\sqrt{91}} \sin \sqrt{91}t \right)$  ft

**6.2.7 (p. 287)**  $y = -\frac{e^{-4t}}{3} (2 + 8t)$  ft    **6.2.8 (p. 287)**  $y = e^{-10t} \left( 9 \cos 4\sqrt{6}t + \frac{45}{2\sqrt{6}} \sin 4\sqrt{6}t \right)$  cm

**6.2.9 (p. 287)**  $y = e^{-3t/2} \left( \frac{3}{2} \cos \frac{\sqrt{41}}{2}t + \frac{9}{2\sqrt{41}} \sin \frac{\sqrt{41}}{2}t \right)$  ft

$$6.2.10 \text{ (p. 287)} \quad y = e^{-\frac{3}{2}t} \left( \frac{1}{2} \cos \frac{\sqrt{119}}{2}t - \frac{9}{2\sqrt{119}} \sin \frac{\sqrt{119}}{2}t \right) \text{ ft}$$

$$6.2.11 \text{ (p. 287)} \quad y = e^{-8t} \left( \frac{1}{4} \cos 8\sqrt{2}t - \frac{1}{4\sqrt{2}} \sin 8\sqrt{2}t \right) \text{ ft}$$

$$6.2.12 \text{ (p. 287)} \quad y = e^{-t} \left( -\frac{1}{3} \cos 3\sqrt{11}t + \frac{14}{9\sqrt{11}} \sin 3\sqrt{11}t \right) \text{ ft}$$

$$6.2.13 \text{ (p. 287)} \quad y_p = \frac{22}{61} \cos 2t + \frac{2}{61} \sin 2t \text{ ft} \quad 6.2.14 \text{ (p. 288)} \quad y = -\frac{2}{3}(e^{-8t} - 2e^{-4t})$$

$$6.2.15 \text{ (p. 288)} \quad y = e^{-2t} \left( \frac{1}{10} \cos 4t - \frac{1}{5} \sin 4t \right) \text{ m} \quad 6.2.16 \text{ (p. 288)} \quad y = e^{-3t}(10 \cos t - 70 \sin t) \text{ cm}$$

$$6.2.17 \text{ (p. 288)} \quad y_p = -\frac{2}{15} \cos 3t + \frac{1}{15} \sin 3t \text{ ft}$$

$$6.2.18 \text{ (p. 288)} \quad y_p = \frac{11}{100} \cos 4t + \frac{27}{100} \sin 4t \text{ cm} \quad 6.2.19 \text{ (p. 288)} \quad y_p = \frac{42}{73} \cos t + \frac{39}{73} \sin t \text{ ft}$$

$$6.2.20 \text{ (p. 288)} \quad y = -\frac{1}{2} \cos 2t + \frac{1}{4} \sin 2t \text{ m} \quad 6.2.21 \text{ (p. 288)} \quad y_p = \frac{1}{c\omega_0}(-\beta \cos \omega_0 t + \alpha \sin \omega_0 t)$$

$$6.2.24 \text{ (p. 288)} \quad y = e^{-ct/2m} \left( y_0 \cos \omega_1 t + \frac{1}{\omega_1} \left( v_0 + \frac{cy_0}{2m} \right) \sin \omega_1 t \right)$$

$$6.2.25 \text{ (p. 288)} \quad y = \frac{r_2 y_0 - v_0}{r_2 - r_1} e^{r_1 t} + \frac{v_0 - r_1 y_0}{r_2 - r_1} e^{r_2 t} \quad 6.2.26 \text{ (p. 289)} \quad y = e^{r_1 t} (y_0 + (v_0 - r_1 y_0)t)$$

### Section 6.3 Answers, pp. 294–295

$$6.3.1 \text{ (p. 294)} \quad I = e^{-15t} \left( 2 \cos 5\sqrt{15}t - \frac{6}{\sqrt{31}} \sin 5\sqrt{31}t \right)$$

$$6.3.2 \text{ (p. 294)} \quad I = e^{-20t} (2 \cos 40t - 101 \sin 40t) \quad 6.3.3 \text{ (p. 294)} \quad I = -\frac{200}{3} e^{-10t} \sin 30t$$

$$6.3.4 \text{ (p. 294)} \quad I = -10e^{-30t} (\cos 40t + 18 \sin 40t) \quad 6.3.5 \text{ (p. 294)} \quad I = -e^{-40t} (2 \cos 30t - 86 \sin 30t)$$

$$6.3.6 \text{ (p. 294)} \quad I_p = -\frac{1}{3} (\cos 10t + 2 \sin 10t) \quad 6.3.7 \text{ (p. 294)} \quad I_p = \frac{20}{37} (\cos 25t - 6 \sin 25t)$$

$$6.3.8 \text{ (p. 294)} \quad I_p = \frac{3}{13} (8 \cos 50t - \sin 50t) \quad 6.3.9 \text{ (p. 294)} \quad I_p = \frac{20}{123} (17 \sin 100t - 11 \cos 100t)$$

$$6.3.10 \text{ (p. 294)} \quad I_p = -\frac{45}{52} (\cos 30t + 8 \sin 30t)$$

$$6.3.12 \text{ (p. 295)} \quad \omega_0 = 1/\sqrt{LC} \quad \text{maximum amplitude} = \sqrt{U^2 + V^2}/R$$

### Section 6.4 Answers, pp. 301–302

$$6.4.1 \text{ (p. 301)} \quad \text{If } e = 1, \text{ then } Y^2 = \rho(\rho - 2X); \text{ if } e \neq 1 \left( X + \frac{e\rho}{1-e^2} \right)^2 + \frac{Y^2}{1-e^2} = \frac{\rho^2}{(1-e^2)^2} \text{ if}; \\ e < 1 \text{ let } X_0 = -\frac{e\rho}{1-e^2}, a = \frac{\rho}{1-e^2}, b = \frac{\rho}{\sqrt{1-e^2}}.$$

$$6.4.2 \text{ (p. 302)} \quad \text{Let } h = r_0^2 \theta_0'; \text{ then } \rho = \frac{h^2}{k}, \quad e = \left[ \left( \frac{\rho}{r_0} - 1 \right)^2 + \left( \frac{\rho r_0'}{h} \right)^2 \right]^{1/2}. \text{ If } e = 0, \text{ then} \\ \theta_0 \text{ is undefined, but also irrelevant if } e \neq 0 \text{ then } \phi = \theta_0 - \alpha, \text{ where } -\pi \leq \alpha < \pi, \cos \alpha = \\ \frac{1}{e} \left( \frac{\rho}{r_0} - 1 \right) \text{ and } \sin \alpha = \frac{\rho r_0'}{eh}.$$

$$6.4.3 \text{ (p. 302)} \quad \text{(a) } e = \frac{\gamma_2 - \gamma_1}{\gamma_1 + \gamma_2} \quad \text{(b) } r_0 = R\gamma_1, \quad r_0' = 0, \quad \theta_0 \text{ arbitrary, } \theta_0' = \left[ \frac{2g\gamma_2}{R\gamma_1^3(\gamma_1 + \gamma_2)} \right]^{1/2}$$

$$6.4.4 \text{ (p. 302)} \quad f(r) = -mh^2 \left( \frac{6c}{r^4} + \frac{1}{r^3} \right) \quad 6.4.5 \text{ (p. 302)} \quad f(r) = -\frac{mh^2(\gamma^2 + 1)}{r^3}$$

$$6.4.6 \text{ (p. 302)} \quad \text{(a) } \frac{d^2 u}{d\theta^2} + \left( 1 - \frac{k}{h^2} \right) u = 0, \quad u(\theta_0) = \frac{1}{r_0}, \quad \frac{du(\theta_0)}{d\theta} = -\frac{r_0'}{h}. \quad \text{(b) with } \gamma =$$

$$\left|1 - \frac{k}{h^2}\right|^{1/2} : \text{(i) } r = r_0 \left( \cosh \gamma(\theta - \theta_0) - \frac{r_0 r'_0}{\gamma h} \sinh \gamma(\theta - \theta_0) \right)^{-1} \quad \text{(ii) } r = r_0 \left( 1 - \frac{r_0 r'_0}{h} (\theta - \theta_0) \right)^{-1};$$

$$\text{(iii) } r = r_0 \left( \cos \gamma(\theta - \theta_0) - \frac{r_0 r'_0}{\gamma h} \sin \gamma(\theta - \theta_0) \right)^{-1}$$

**Section 7.1 Answers, pp. 316–319**

**7.1.1 (p. 316)** (a)  $R = 2; I = (-1, 3)$ ; (b)  $R = 1/2; I = (3/2, 5/2)$  (c)  $R = 0$ ; (d)  $R = 16$ ;  
 $I = (-14, 18)$  (e)  $R = \infty; I = (-\infty, \infty)$  (f)  $R = 4/3; I = (-25/3, -17/3)$

**7.1.3 (p. 316)** (a)  $R = 1; I = (0, 2)$  (b)  $R = \sqrt{2}; I = (-2 - \sqrt{2}, -2 + \sqrt{2})$ ; (c)  $R = \infty$ ;  
 $I = (-\infty, \infty)$  (d)  $R = 0$  (e)  $R = \sqrt{3}; I = (-\sqrt{3}, \sqrt{3})$  (f)  $R = 1; I = (0, 2)$

**7.1.5 (p. 316)** (a)  $R = 3; I = (0, 6)$  (b)  $R = 1; I = (-1, 1)$  (c)  $R = 1/\sqrt{3}$   
 $I = (3 - 1/\sqrt{3}, 3 + 1/\sqrt{3})$  (d)  $R = \infty; I = (-\infty, \infty)$  (e)  $R = 0$  (f)  $R = 2$ ;  
 $I = (-1, 3)$

**7.1.11 (p. 317)**  $b_n = 2(n+2)(n+1)a_{n+2} + (n+1)na_{n+1} + (n+3)a_n$

**7.1.12 (p. 317)**  $b_0 = 2a_2 - 2a_0$   $b_n = (n+2)(n+1)a_{n+2} + [3n(n-1) - 2]a_n + 3(n-1)a_{n-1}$ ,  $n \geq 1$

**7.1.13 (p. 317)**  $b_n = (n+2)(n+1)a_{n+2} + 2(n+1)a_{n+1} + (2n^2 - 5n + 4)a_n$

**7.1.14 (p. 317)**  $b_n = (n+2)(n+1)a_{n+2} + 2(n+1)a_{n+1} + (n^2 - 2n + 3)a_n$

**7.1.15 (p. 318)**  $b_n = (n+2)(n+1)a_{n+2} + (3n^2 - 5n + 4)a_n$

**7.1.16 (p. 318)**  $b_0 = -2a_2 + 2a_1 + a_0$ ,  
 $b_n = -(n+2)(n+1)a_{n+2} + (n+1)(n+2)a_{n+1} + (2n+1)a_n + a_{n-1}$ ,  $n \geq 2$

**7.1.17 (p. 318)**  $b_0 = 8a_2 + 4a_1 - 6a_0$ ,  
 $b_n = 4(n+2)(n+1)a_{n+2} + 4(n+1)^2a_{n+1} + (n^2 + n - 6)a_n - 3a_{n-1}$ ,  $n \geq 1$

**7.1.21 (p. 319)**  $b_0 = (r+1)(r+2)a_0$ ,  
 $b_n = (n+r+1)(n+r+2)a_n - (n+r-2)^2a_{n-1}$ ,  $n \geq 1$ .

**7.1.22 (p. 319)**  $b_0 = (r-2)(r+2)a_0$ ,  
 $b_n = (n+r-2)(n+r+2)a_n + (n+r+2)(n+r-3)a_{n-1}$ ,  $n \geq 14$

**7.1.23 (p. 319)**  $b_0 = (r-1)^2a_0$ ,  $b_1 = r^2a_1 + (r+2)(r+3)a_0$ ,  
 $b_n = (n+r-1)^2a_n + (n+r+1)(n+r+2)a_{n-1} + (n+r-1)a_{n-2}$ ,  $n \geq 2$

**7.1.24 (p. 319)**  $b_0 = r(r+1)a_0$ ,  $b_1 = (r+1)(r+2)a_1 + 3(r+1)(r+2)a_0$ ,  
 $b_n = (n+r)(n+r+1)a_n + 3(n+r)(n+r+1)a_{n-1} + (n+r)a_{n-2}$ ,  $n \geq 2$

**7.1.25 (p. 319)**  $b_0 = (r+2)(r+1)a_0$   $b_1 = (r+3)(r+2)a_1$ ,  
 $b_n = (n+r+2)(n+r+1)a_n + 2(n+r-1)(n+r-3)a_{n-2}$ ,  $n \geq 2$

**7.1.26 (p. 319)**  $b_0 = 2(r+1)(r+3)a_0$ ,  $b_1 = 2(r+2)(r+4)a_1$ ,  
 $b_n = 2(n+r+1)(n+r+3)a_n + (n+r-3)(n+r)a_{n-2}$ ,  $n \geq 2$

**Section 7.2 Answers, pp. 328–333**

**7.2.1 (p. 328)**  $y = a_0 \sum_{m=0}^{\infty} (-1)^m (2m+1)x^{2m} + a_1 \sum_{m=0}^{\infty} (-1)^m (m+1)x^{2m+1}$

**7.2.2 (p. 328)**  $y = a_0 \sum_{m=0}^{\infty} (-1)^{m+1} \frac{x^{2m}}{2m-1} + a_1 x$

**7.2.3 (p. 328)**  $y = a_0(1 - 10x^2 + 5x^4) + a_1 \left( x - 2x^3 + \frac{1}{5}x^5 \right)$

**7.2.4 (p. 328)**  $y = a_0 \sum_{m=0}^{\infty} (m+1)(2m+1)x^{2m} + \frac{a_1}{3} \sum_{m=0}^{\infty} (m+1)(2m+3)x^{2m+1}$

**7.2.5 (p. 328)**  $y = a_0 \sum_{m=0}^{\infty} (-1)^m \left[ \prod_{j=0}^{m-1} \frac{4j+1}{2j+1} \right] x^{2m} + a_1 \sum_{m=0}^{\infty} (-1)^m \left[ \prod_{j=0}^{m-1} (4j+3) \right] \frac{x^{2m+1}}{2^m m!}$

$$7.2.6 \text{ (p. 328)} \quad y = a_0 \sum_{m=0}^{\infty} (-1)^m \left[ \prod_{j=0}^{m-1} \frac{(4j+1)^2}{2j+1} \right] \frac{x^{2m}}{8^m m!} + a_1 \sum_{m=0}^{\infty} (-1)^m \left[ \prod_{j=0}^{m-1} \frac{(4j+3)^2}{2j+3} \right] \frac{x^{2m+1}}{8^m m!}$$

$$7.2.7 \text{ (p. 328)} \quad y = a_0 \sum_{m=0}^{\infty} \frac{2^m m!}{\prod_{j=0}^{m-1} (2j+1)} x^{2m} + a_1 \sum_{m=0}^{\infty} \frac{\prod_{j=0}^{m-1} (2j+3)}{2^m m!} x^{2m+1}$$

$$7.2.8 \text{ (p. 328)} \quad y = a_0 \left( 1 - 14x^2 + \frac{35}{3}x^4 \right) + a_1 \left( x - 3x^3 + \frac{3}{5}x^5 + \frac{1}{35}x^7 \right)$$

$$7.2.9 \text{ (p. 329)} \quad \text{(a)} \quad y = a_0 \sum_{m=0}^{\infty} (-1)^m \frac{x^{2m}}{\prod_{j=0}^{m-1} (2j+1)} + a_1 \sum_{m=0}^{\infty} (-1)^m \frac{x^{2m+1}}{2^m m!}$$

$$7.2.10 \text{ (p. 329)} \quad \text{(a)} \quad y = a_0 \sum_{m=0}^{\infty} (-1)^m \left[ \prod_{j=0}^{m-1} \frac{4j+3}{2j+1} \right] \frac{x^{2m}}{2^m m!} + a_1 \sum_{m=0}^{\infty} (-1)^m \left[ \prod_{j=0}^{m-1} \frac{4j+5}{2j+3} \right] \frac{x^{2m+1}}{2^m m!}$$

$$7.2.11 \text{ (p. 329)} \quad y = 2 - x - x^2 + \frac{1}{3}x^3 + \frac{5}{12}x^4 - \frac{1}{6}x^5 - \frac{17}{72}x^6 + \frac{13}{126}x^7 + \dots$$

$$7.2.12 \text{ (p. 329)} \quad y = 1 - x + 3x^2 - \frac{5}{2}x^3 + 5x^4 - \frac{21}{8}x^5 + 3x^6 - \frac{11}{16}x^7 + \dots$$

$$7.2.13 \text{ (p. 329)} \quad y = 2 - x - 2x^2 + \frac{1}{3}x^3 + 3x^4 - \frac{5}{6}x^5 - \frac{49}{5}x^6 + \frac{45}{14}x^7 + \dots$$

$$7.2.16 \text{ (p. 330)} \quad y = a_0 \sum_{m=0}^{\infty} \frac{(x-3)^{2m}}{(2m)!} + a_1 \sum_{m=0}^{\infty} \frac{(x-3)^{2m+1}}{(2m+1)!}$$

$$7.2.17 \text{ (p. 330)} \quad y = a_0 \sum_{m=0}^{\infty} \frac{(x-3)^{2m}}{2^m m!} + a_1 \sum_{m=0}^{\infty} \frac{(x-3)^{2m+1}}{\prod_{j=0}^{m-1} (2j+3)}$$

$$7.2.18 \text{ (p. 330)} \quad y = a_0 \sum_{m=0}^{\infty} \left[ \prod_{j=0}^{m-1} (2j+3) \right] \frac{(x-1)^{2m}}{m!} + a_1 \sum_{m=0}^{\infty} \frac{4^m (m+1)!}{\prod_{j=0}^{m-1} (2j+3)} (x-1)^{2m+1}$$

$$7.2.19 \text{ (p. 330)} \quad y = a_0 \left( 1 - 6(x-2)^2 + \frac{4}{3}(x-2)^4 + \frac{8}{135}(x-2)^6 \right) + a_1 \left( (x-2) - \frac{10}{9}(x-2)^3 \right)$$

$$7.2.20 \text{ (p. 330)} \quad y = a_0 \sum_{m=0}^{\infty} (-1)^m \left[ \prod_{j=0}^{m-1} (2j+1) \right] \frac{3^m}{4^m m!} (x+1)^{2m} + a_1 \sum_{m=0}^{\infty} (-1)^m \frac{3^m m!}{\prod_{j=0}^{m-1} (2j+3)} (x+1)^{2m+1}$$

$$7.2.21 \text{ (p. 330)} \quad y = -1 + 2x + \frac{3}{8}x^2 - \frac{1}{3}x^3 - \frac{3}{128}x^4 - \frac{1}{1024}x^6 + \dots$$

$$7.2.22 \text{ (p. 330)} \quad y = -2 + 3(x-3) + 3(x-3)^2 - 2(x-3)^3 - \frac{5}{4}(x-3)^4 + \frac{3}{5}(x-3)^5 + \frac{7}{24}(x-3)^6 - \frac{4}{35}(x-3)^7 + \dots$$

$$7.2.23 \text{ (p. 330)} \quad y = -1 + (x-1) + 3(x-1)^2 - \frac{5}{2}(x-1)^3 - \frac{27}{4}(x-1)^4 + \frac{21}{4}(x-1)^5 + \frac{27}{2}(x-1)^6 - \frac{81}{8}(x-1)^7 + \dots$$

$$7.2.24 \text{ (p. 330)} \quad y = 4 - 6(x-3) - 2(x-3)^2 + (x-3)^3 + \frac{3}{2}(x-3)^4 - \frac{5}{4}(x-3)^5 - \frac{49}{20}(x-3)^6 + \frac{135}{56}(x-3)^7 + \dots$$

$$7.2.25 \text{ (p. 330)} \quad y = 3 - 4(x-4) + 15(x-4)^2 - 4(x-4)^3 + \frac{15}{4}(x-4)^4 - \frac{1}{5}(x-4)^5$$

$$7.2.26 \text{ (p. 330)} \quad y = 3 - 3(x+1) - 30(x+1)^2 + \frac{20}{3}(x+1)^3 + 20(x+1)^4 - \frac{4}{3}(x+1)^5 - \frac{8}{9}(x+1)^6$$

$$7.2.27 \text{ (p. 330)} \quad \text{(a)} \quad y = a_0 \sum_{m=0}^{\infty} (-1)^m x^{2m} + a_1 \sum_{m=0}^{\infty} (-1)^m x^{2m+1} \quad \text{(b)} \quad y = \frac{a_0 + a_1 x}{1 + x^2}$$

$$7.2.33 \text{ (p. 333)} \quad y = a_0 \sum_{m=0}^{\infty} \frac{x^{3m}}{3^m m! \prod_{j=0}^{m-1} (3j+2)} + a_1 \sum_{m=0}^{\infty} \frac{x^{3m+1}}{3^m m! \prod_{j=0}^{m-1} (3j+4)}$$

$$7.2.34 \text{ (p. 333)} \quad y = a_0 \sum_{m=0}^{\infty} \left(\frac{2}{3}\right)^m \left[ \prod_{j=0}^{m-1} (3j+2) \right] \frac{x^{3m}}{m!} + a_1 \sum_{m=0}^{\infty} \frac{6^m m!}{\prod_{j=0}^{m-1} (3j+4)} x^{3m+1}$$

$$7.2.35 \text{ (p. 333)} \quad y = a_0 \sum_{m=0}^{\infty} (-1)^m \frac{3^m m!}{\prod_{j=0}^{m-1} (3j+2)} x^{3m} + a_1 \sum_{m=0}^{\infty} (-1)^m \left[ \prod_{j=0}^{m-1} (3j+4) \right] \frac{x^{3m+1}}{3^m m!}$$

$$7.2.36 \text{ (p. 333)} \quad y = a_0(1 - 4x^3 + 4x^6) + a_1 \sum_{m=0}^{\infty} 2^m \left[ \prod_{j=0}^{m-1} \frac{3j-5}{3j+4} \right] x^{3m+1}$$

$$7.2.37 \text{ (p. 333)} \quad y = a_0 \left(1 + \frac{21}{2}x^3 + \frac{42}{5}x^6 + \frac{7}{20}x^9\right) + a_1 \left(x + 4x^4 + \frac{10}{7}x^7\right)$$

$$7.2.39 \text{ (p. 333)} \quad y = a_0 \sum_{m=0}^{\infty} (-2)^m \left[ \prod_{j=0}^{m-1} \frac{5j+1}{5j+4} \right] x^{5m} + a_1 \sum_{m=0}^{\infty} \left(-\frac{2}{5}\right)^m \left[ \prod_{j=0}^{m-1} (5j+2) \right] \frac{x^{5m+1}}{m!}$$

$$7.2.40 \text{ (p. 333)} \quad y = a_0 \sum_{m=0}^{\infty} (-1)^m \frac{x^{4m}}{4^m m! \prod_{j=0}^{m-1} (4j+3)} + a_1 \sum_{m=0}^{\infty} (-1)^m \frac{x^{4m+1}}{4^m m! \prod_{j=0}^{m-1} (4j+5)}$$

$$7.2.41 \text{ (p. 333)} \quad y = a_0 \sum_{m=0}^{\infty} (-1)^m \frac{x^{7m}}{\prod_{j=0}^{m-1} (7j+6)} + a_1 \sum_{m=0}^{\infty} (-1)^m \frac{x^{7m+1}}{7^m m!}$$

$$7.2.42 \text{ (p. 333)} \quad y = a_0 \left(1 - \frac{9}{7}x^8\right) + a_1 \left(x - \frac{7}{9}x^9\right)$$

$$7.2.43 \text{ (p. 333)} \quad y = a_0 \sum_{m=0}^{\infty} x^{6m} + a_1 \sum_{m=0}^{\infty} x^{6m+1}$$

$$7.2.44 \text{ (p. 333)} \quad y = a_0 \sum_{m=0}^{\infty} (-1)^m \frac{x^{6m}}{\prod_{j=0}^{m-1} (6j+5)} + a_1 \sum_{m=0}^{\infty} (-1)^m \frac{x^{6m+1}}{6^m m!}$$

**Section 7.3 Answers, pp. 337–341**

$$7.3.1 \text{ (p. 337)} \quad y = 2 - 3x - 2x^2 + \frac{7}{2}x^3 - \frac{55}{12}x^4 + \frac{59}{8}x^5 - \frac{83}{6}x^6 + \frac{9547}{336}x^7 + \dots$$

$$7.3.2 \text{ (p. 337)} \quad y = -1 + 2x - 4x^3 + 4x^4 + 4x^5 - 12x^6 + 4x^7 + \dots$$

$$7.3.3 \text{ (p. 337)} \quad y = 1 + x^2 - \frac{2}{3}x^3 + \frac{11}{6}x^4 - \frac{9}{5}x^5 + \frac{329}{90}x^6 - \frac{1301}{315}x^7 + \dots$$

$$7.3.4 \text{ (p. 337)} \quad y = x - x^2 - \frac{7}{2}x^3 + \frac{15}{2}x^4 + \frac{45}{8}x^5 - \frac{261}{8}x^6 + \frac{207}{16}x^7 + \dots$$

$$7.3.5 \text{ (p. 337)} \quad y = 4 + 3x - \frac{15}{4}x^2 + \frac{1}{4}x^3 + \frac{11}{16}x^4 - \frac{5}{16}x^5 + \frac{1}{20}x^6 + \frac{1}{120}x^7 + \dots$$

$$7.3.6 \text{ (p. 337)} \quad y = 7 + 3x - \frac{16}{3}x^2 + \frac{13}{3}x^3 - \frac{23}{9}x^4 + \frac{10}{9}x^5 - \frac{7}{27}x^6 - \frac{1}{9}x^7 + \dots$$

$$7.3.7 \text{ (p. 337)} \quad y = 2 + 5x - \frac{7}{4}x^2 - \frac{3}{16}x^3 + \frac{37}{192}x^4 - \frac{7}{192}x^5 - \frac{1}{1920}x^6 + \frac{19}{11520}x^7 + \dots$$

$$7.3.8 \text{ (p. 337)} \quad y = 1 - (x-1) + \frac{4}{3}(x-1)^3 - \frac{4}{3}(x-1)^4 - \frac{4}{5}(x-1)^5 + \frac{136}{45}(x-1)^6 - \frac{104}{63}(x-1)^7 + \dots$$

$$7.3.9 \text{ (p. 337)} \quad y = 1 - (x+1) + 4(x+1)^2 - \frac{13}{3}(x+1)^3 + \frac{77}{6}(x+1)^4 - \frac{278}{15}(x+1)^5 + \frac{1942}{45}(x+1)^6 - \frac{23332}{315}(x+1)^7 + \dots$$

$$7.3.10 \text{ (p. 337)} \quad y = 2 - (x-1) - \frac{1}{2}(x-1)^2 + \frac{5}{3}(x-1)^3 - \frac{19}{12}(x-1)^4 + \frac{7}{30}(x-1)^5 + \frac{59}{45}(x-1)^6 - \frac{1091}{630}(x-1)^7 + \dots$$

$$7.3.11 \text{ (p. 337)} \quad y = -2 + 3(x+1) - \frac{1}{2}(x+1)^2 - \frac{2}{3}(x+1)^3 + \frac{5}{8}(x+1)^4 - \frac{11}{30}(x+1)^5 + \frac{29}{144}(x+1)^6 - \frac{101}{840}(x+1)^7 + \dots$$

$$7.3.12 \text{ (p. 337)} \quad y = 1 - 2(x-1) - 3(x-1)^2 + 8(x-1)^3 - 4(x-1)^4 - \frac{42}{5}(x-1)^5 + 19(x-1)^6 - \frac{604}{35}(x-1)^7 + \dots$$

$$7.3.19 \text{ (p. 339)} \quad y = 2 - 7x - 4x^2 - \frac{17}{6}x^3 - \frac{3}{4}x^4 - \frac{9}{40}x^5 + \dots$$

$$7.3.20 \text{ (p. 339)} \quad y = 1 - 2(x-1) + \frac{1}{2}(x-1)^2 - \frac{1}{6}(x-1)^3 + \frac{5}{36}(x-1)^4 - \frac{73}{1080}(x-1)^5 + \dots$$

$$7.3.21 \text{ (p. 339)} \quad y = 2 - (x+2) - \frac{7}{2}(x+2)^2 + \frac{4}{3}(x+2)^3 - \frac{1}{24}(x+2)^4 + \frac{1}{60}(x+2)^5 + \dots$$

$$7.3.22 \text{ (p. 339)} \quad y = 2 - 2(x+3) - (x+3)^2 + (x+3)^3 - \frac{11}{12}(x+3)^4 + \frac{67}{60}(x+3)^5 + \dots$$

$$7.3.23 \text{ (p. 339)} \quad y = -1 + 2x + \frac{1}{3}x^3 - \frac{5}{12}x^4 + \frac{2}{5}x^5 + \dots$$

$$7.3.24 \text{ (p. 339)} \quad y = 2 - 3(x+1) + \frac{7}{2}(x+1)^2 - 5(x+1)^3 + \frac{197}{24}(x+1)^4 - \frac{287}{20}(x+1)^5 + \dots$$

$$7.3.25 \text{ (p. 339)} \quad y = -2 + 3(x+2) - \frac{9}{2}(x+2)^2 + \frac{11}{6}(x+2)^3 + \frac{5}{24}(x+2)^4 + \frac{7}{20}(x+2)^5 + \dots$$

$$7.3.26 \text{ (p. 339)} \quad y = 2 - 4(x-2) - \frac{1}{2}(x-2)^2 + \frac{2}{9}(x-2)^3 + \frac{49}{432}(x-2)^4 + \frac{23}{1080}(x-2)^5 + \dots$$

$$7.3.27 \text{ (p. 339)} \quad y = 1 + 2(x+4) - \frac{1}{6}(x+4)^2 - \frac{10}{27}(x+4)^3 + \frac{19}{648}(x+4)^4 + \frac{13}{324}(x+4)^5 + \dots$$

$$7.3.28 \text{ (p. 339)} \quad y = -1 + 2(x+1) - \frac{1}{4}(x+1)^2 + \frac{1}{2}(x+1)^3 - \frac{65}{96}(x+1)^4 + \frac{67}{80}(x+1)^5 + \dots$$

$$7.3.31 \text{ (p. 341)} \quad \text{(a)} \quad y = \frac{c_1}{1+x} + \frac{c_2}{1+2x} \quad \text{(b)} \quad y = \frac{c_1}{1-2x} + \frac{c_2}{1-3x} \quad \text{(c)} \quad y = \frac{c_1}{1-2x} + \frac{c_2 x}{(1-2x)^2}$$

$$\text{(d)} \quad y = \frac{c_1}{2+x} + \frac{c_2 x}{(2+x)^2} \quad \text{(e)} \quad y = \frac{c_1}{2+x} + \frac{c_2}{2+3x}$$

$$7.3.32 \text{ (p. 341)} \quad y = 1 - 2x - \frac{3}{2}x^2 + \frac{5}{3}x^3 + \frac{17}{24}x^4 - \frac{11}{20}x^5 + \dots$$

$$7.3.33 \text{ (p. 341)} \quad y = 1 - 2x - \frac{5}{2}x^2 + \frac{2}{3}x^3 - \frac{3}{8}x^4 + \frac{1}{3}x^5 + \dots$$

$$7.3.34 \text{ (p. 341)} \quad y = 6 - 2x + 9x^2 + \frac{2}{3}x^3 - \frac{23}{4}x^4 - \frac{3}{10}x^5 + \dots$$

$$7.3.35 \text{ (p. 341)} \quad y = 2 - 5x + 2x^2 - \frac{10}{3}x^3 + \frac{3}{2}x^4 - \frac{25}{12}x^5 + \dots$$

$$7.3.36 \text{ (p. 341)} \quad y = 3 + 6x - 3x^2 + x^3 - 2x^4 - \frac{17}{20}x^5 + \dots$$

$$7.3.37 \text{ (p. 341)} \quad y = 3 - 2x - 3x^2 + \frac{3}{2}x^3 + \frac{3}{2}x^4 - \frac{49}{80}x^5 + \dots$$

$$7.3.38 \text{ (p. 341)} \quad y = -2 + 3x + \frac{4}{3}x^2 - x^3 - \frac{19}{54}x^4 + \frac{13}{60}x^5 + \dots$$

$$7.3.39 \text{ (p. 341)} \quad y_1 = \sum_{m=0}^{\infty} \frac{(-1)^m x^{2m}}{m!} = e^{-x^2}, \quad y_2 = \sum_{m=0}^{\infty} \frac{(-1)^m x^{2m+1}}{m!} = x e^{-x^2}$$

$$7.3.40 \text{ (p. 341)} \quad y = -2 + 3x + x^2 - \frac{1}{6}x^3 - \frac{3}{4}x^4 + \frac{31}{120}x^5 + \dots$$

$$7.3.41 \text{ (p. 341)} \quad y = 2 + 3x - \frac{7}{2}x^2 - \frac{5}{6}x^3 + \frac{41}{24}x^4 + \frac{41}{120}x^5 + \dots$$

$$7.3.42 \text{ (p. 341)} \quad y = -3 + 5x - 5x^2 + \frac{23}{6}x^3 - \frac{23}{12}x^4 + \frac{11}{30}x^5 + \dots$$

$$7.3.43 \text{ (p. 341)} \quad y = -2 + 3(x-1) + \frac{3}{2}(x-1)^2 - \frac{17}{12}(x-1)^3 - \frac{1}{12}(x-1)^4 + \frac{1}{8}(x-1)^5 + \dots$$

$$7.3.44 \text{ (p. 341)} \quad y = 2 - 3(x+2) + \frac{1}{2}(x+2)^2 - \frac{1}{3}(x+2)^3 + \frac{31}{24}(x+2)^4 - \frac{53}{120}(x+2)^5 + \dots$$

$$7.3.45 \text{ (p. 341)} \quad y = 1 - 2x + \frac{3}{2}x^2 - \frac{11}{6}x^3 + \frac{15}{8}x^4 - \frac{71}{60}x^5 + \dots$$

$$7.3.46 \text{ (p. 341)} \quad y = 2 - (x+2) - \frac{7}{2}(x+2)^2 - \frac{43}{6}(x+2)^3 - \frac{203}{24}(x+2)^4 - \frac{167}{30}(x+2)^5 + \dots$$

$$7.3.47 \text{ (p. 341)} \quad y = 2 - x - x^2 + \frac{7}{6}x^3 - x^4 + \frac{89}{120}x^5 + \dots$$

$$7.3.48 \text{ (p. 341)} \quad y = 1 + \frac{3}{2}(x-1)^2 + \frac{1}{6}(x-1)^3 - \frac{1}{8}(x-1)^5 + \dots$$

$$7.3.49 \text{ (p. 341)} \quad y = 1 - 2(x-3) + \frac{1}{2}(x-3)^2 - \frac{1}{6}(x-3)^3 + \frac{1}{4}(x-3)^4 - \frac{1}{6}(x-3)^5 + \dots$$

**Section 7.4 Answers, pp. 346–347**

$$7.4.1 \text{ (p. 346)} \quad y = c_1x^{-4} + c_2x^{-2} \quad 7.4.2 \text{ (p. 346)} \quad y = c_1x + c_2x^7$$

$$7.4.3 \text{ (p. 346)} \quad y = x(c_1 + c_2 \ln x) \quad 7.4.4 \text{ (p. 346)} \quad y = x^{-2}(c_1 + c_2 \ln x)$$

$$7.4.5 \text{ (p. 346)} \quad y = c_1 \cos(\ln x) + c_2 \sin(\ln x) \quad 7.4.6 \text{ (p. 346)} \quad y = x^2[c_1 \cos(3 \ln x) + c_2 \sin(3 \ln x)]$$

$$7.4.7 \text{ (p. 346)} \quad y = c_1x + \frac{c_2}{x^3} \quad 7.4.8 \text{ (p. 346)} \quad y = c_1x^{2/3} + c_2x^{3/4} \quad 7.4.9 \text{ (p. 346)} \quad y = x^{-1/2}(c_1 + c_2 \ln x)$$

$$7.4.10 \text{ (p. 346)} \quad y = c_1x + c_2x^{1/3} \quad 7.4.11 \text{ (p. 346)} \quad y = c_1x^2 + c_2x^{1/2} \quad 7.4.12 \text{ (p. 346)} \quad y = \frac{1}{x} [c_1 \cos(2 \ln x) + c_2 \sin(2 \ln x)]$$

$$7.4.13 \text{ (p. 346)} \quad y = x^{-1/3}(c_1 + c_2 \ln x) \quad 7.4.14 \text{ (p. 346)} \quad y = x [c_1 \cos(3 \ln x) + c_2 \sin(3 \ln x)]$$

$$7.4.15 \text{ (p. 346)} \quad y = c_1x^3 + \frac{c_2}{x^2} \quad 7.4.16 \text{ (p. 346)} \quad y = \frac{c_1}{x} + c_2x^{1/2} \quad 7.4.17 \text{ (p. 346)} \quad y = x^2(c_1 + c_2 \ln x)$$

$$7.4.18 \text{ (p. 346)} \quad y = \frac{1}{x^2} \left[ c_1 \cos\left(\frac{1}{\sqrt{2}} \ln x\right) + c_2 \sin\left(\frac{1}{\sqrt{2}} \ln x\right) \right]$$

**Section 7.5 Answers, pp. 357–364**

$$7.5.1 \text{ (p. 357)} \quad y_1 = x^{1/2} \left( 1 - \frac{1}{5}x - \frac{2}{35}x^2 + \frac{31}{315}x^3 + \dots \right) \quad y_2 = x^{-1} \left( 1 + x + \frac{1}{2}x^2 - \frac{1}{6}x^3 + \dots \right);$$

$$7.5.2 \text{ (p. 357)} \quad y_1 = x^{1/3} \left( 1 - \frac{2}{3}x + \frac{8}{9}x^2 - \frac{40}{81}x^3 + \dots \right); \quad y_2 = 1 - x + \frac{6}{5}x^2 - \frac{4}{5}x^3 + \dots$$

$$7.5.3 \text{ (p. 357)} \quad y_1 = x^{1/3} \left( 1 - \frac{4}{7}x - \frac{7}{45}x^2 + \frac{970}{2457}x^3 + \dots \right); \quad y_2 = x^{-1} \left( 1 - x^2 + \frac{2}{3}x^3 + \dots \right)$$

$$7.5.4 \text{ (p. 357)} \quad y_1 = x^{1/4} \left( 1 - \frac{1}{2}x - \frac{19}{104}x^2 + \frac{1571}{10608}x^3 + \dots \right); \quad y_2 = x^{-1} \left( 1 + 2x - \frac{11}{6}x^2 - \frac{1}{7}x^3 + \dots \right)$$

$$7.5.5 \text{ (p. 357)} \quad y_1 = x^{1/3} \left( 1 - x + \frac{28}{31}x^2 - \frac{1111}{1333}x^3 + \dots \right); \quad y_2 = x^{-1/4} \left( 1 - x + \frac{7}{8}x^2 - \frac{19}{24}x^3 + \dots \right);$$

$$7.5.6 \text{ (p. 357)} \quad y_1 = x^{1/5} \left( 1 - \frac{6}{25}x - \frac{1217}{625}x^2 + \frac{41972}{46875}x^3 + \dots \right); \quad y_2 = x - \frac{1}{4}x^2 - \frac{35}{18}x^3 + \frac{11}{12}x^4 + \dots$$

$$7.5.7 \text{ (p. 357)} \quad y_1 = x^{3/2} \left( 1 - x + \frac{11}{26}x^2 - \frac{109}{1326}x^3 + \dots \right); \quad y_2 = x^{1/4} \left( 1 + 4x - \frac{131}{24}x^2 + \frac{39}{14}x^3 + \dots \right)$$

$$7.5.8 \text{ (p. 357)} \quad y_1 = x^{1/3} \left( 1 - \frac{1}{3}x + \frac{2}{15}x^2 - \frac{5}{63}x^3 + \dots \right); \quad y_2 = x^{-1/6} \left( 1 - \frac{1}{12}x^2 + \frac{1}{18}x^3 + \dots \right)$$

$$7.5.9 \text{ (p. 357)} \quad y_1 = 1 - \frac{1}{14}x^2 + \frac{1}{105}x^3 + \dots; \quad y_2 = x^{-1/3} \left( 1 - \frac{1}{18}x - \frac{71}{405}x^2 + \frac{719}{34992}x^3 + \dots \right)$$

$$7.5.10 \text{ (p. 358)} \quad y_1 = x^{1/5} \left( 1 + \frac{3}{17}x - \frac{7}{153}x^2 - \frac{547}{5661}x^3 + \dots \right); \quad y_2 = x^{-1/2} \left( 1 + x + \frac{14}{13}x^2 - \frac{556}{897}x^3 + \dots \right)$$

$$7.5.14 \text{ (p. 358)} \quad y_1 = x^{1/2} \sum_{n=0}^{\infty} \frac{(-2)^n}{\prod_{j=1}^n (2j+3)} x^n; \quad y_2 = x^{-1} \sum_{n=0}^{\infty} \frac{(-1)^n}{n!} x^n$$

$$7.5.15 \text{ (p. 358)} \quad y_1 = x^{1/3} \sum_{n=0}^{\infty} \frac{(-1)^n \prod_{j=1}^n (3j+1)}{9^n n!} x^n; \quad y_2 = x^{-1}$$

$$7.5.16 \text{ (p. 358)} \quad y_1 = x^{1/2} \sum_{n=0}^{\infty} \frac{(-1)^n}{2^n n!} x^n; \quad y_2 = \frac{1}{x^2} \sum_{n=0}^{\infty} \frac{(-1)^n}{\prod_{j=1}^n (2j-5)} x^n$$

$$7.5.17 \text{ (p. 358)} \quad y_1 = x \sum_{n=0}^{\infty} \frac{(-1)^n}{\prod_{j=1}^n (3j+4)} x^n; \quad y_2 = x^{-1/3} \sum_{n=0}^{\infty} \frac{(-1)^n}{3^n n!} x^n$$

$$7.5.18 \text{ (p. 358)} \quad y_1 = x \sum_{n=0}^{\infty} \frac{2^n}{n! \prod_{j=1}^n (2j+1)} x^n; \quad y_2 = x^{1/2} \sum_{n=0}^{\infty} \frac{2^n}{n! \prod_{j=1}^n (2j-1)} x^n$$

$$7.5.19 \text{ (p. 358)} \quad y_1 = x^{1/3} \sum_{n=0}^{\infty} \frac{1}{n! \prod_{j=1}^n (3j+2)} x^n; \quad y_2 = x^{-1/3} \sum_{n=0}^{\infty} \frac{1}{n! \prod_{j=1}^n (3j-2)} x^n$$

$$7.5.20 \text{ (p. 358)} \quad y_1 = x \left( 1 + \frac{2}{7}x + \frac{1}{70}x^2 \right); \quad y_2 = x^{-1/3} \sum_{n=0}^{\infty} \frac{(-1)^n}{3^n n!} \left( \prod_{j=1}^n \frac{3j-13}{3j-4} \right) x^n$$

$$7.5.21 \text{ (p. 358)} \quad y_1 = x^{1/2} \sum_{n=0}^{\infty} (-1)^n \left( \prod_{j=1}^n \frac{2j+1}{6j+1} \right); \quad x^n y_2 = x^{1/3} \sum_{n=0}^{\infty} \frac{(-1)^n}{9^n n!} \left( \prod_{j=1}^n (3j+1) \right) x^n$$

$$7.5.22 \text{ (p. 358)} \quad y_1 = x \sum_{n=0}^{\infty} \frac{(-1)^n (n+2)!}{2 \prod_{j=1}^n (4j+3)}; \quad x^n y_2 = x^{1/4} \sum_{n=0}^{\infty} \frac{(-1)^n}{16^n n!} \prod_{j=1}^n (4j+5) x^n$$

$$7.5.23 \text{ (p. 358)} \quad y_1 = x^{-1/2} \sum_{n=0}^{\infty} \frac{(-1)^n}{n! \prod_{j=1}^n (2j+1)} x^n; \quad y_2 = x^{-1} \sum_{n=0}^{\infty} \frac{(-1)^n}{n! \prod_{j=1}^n (2j-1)} x^n$$

$$7.5.24 \text{ (p. 358)} \quad y_1 = x^{1/3} \sum_{n=0}^{\infty} \frac{(-1)^n}{n!} \left( \frac{2}{9} \right)^n \left( \prod_{j=1}^n (6j+5) \right) x^n; \quad y_2 = x^{-1} \sum_{n=0}^{\infty} (-1)^n 2^n \left( \prod_{j=1}^n \frac{2j-1}{3j-4} \right) x^n$$

$$7.5.25 \text{ (p. 358)} \quad y_1 = 4x^{1/3} \sum_{n=0}^{\infty} \frac{1}{6^n n! (3n+4)} x^n; \quad x^{-1}$$

$$7.5.28 \text{ (p. 359)} \quad y_1 = x^{1/2} \left( 1 - \frac{9}{40}x + \frac{5}{128}x^2 - \frac{245}{39936}x^3 + \dots \right); \quad y_2 = x^{1/4} \left( 1 - \frac{25}{96}x + \frac{675}{14336}x^2 - \frac{38025}{5046272}x^3 + \dots \right)$$

$$7.5.29 \text{ (p. 359)} \quad y_1 = x^{1/3} \left( 1 + \frac{32}{117}x - \frac{28}{1053}x^2 + \frac{4480}{540189}x^3 + \dots \right); \quad y_2 = x^{-3} \left( 1 + \frac{32}{7}x + \frac{48}{7}x^2 \right)$$

$$7.5.30 \text{ (p. 359)} \quad y_1 = x^{1/2} \left( 1 - \frac{5}{8}x + \frac{55}{96}x^2 - \frac{935}{1536}x^3 + \dots \right); \quad y_2 = x^{-1/2} \left( 1 + \frac{1}{4}x - \frac{5}{32}x^2 - \frac{55}{384}x^3 + \dots \right).$$

$$7.5.31 \text{ (p. 359)} \quad y_1 = x^{1/2} \left( 1 - \frac{3}{4}x + \frac{5}{96}x^2 + \frac{5}{4224}x^3 + \dots \right); \quad y_2 = x^{-2} (1 + 8x + 60x^2 - 160x^3 + \dots)$$

$$7.5.32 \text{ (p. 359)} \quad y_1 = x^{-1/3} \left( 1 - \frac{10}{63}x + \frac{200}{7371}x^2 - \frac{17600}{3781323}x^3 + \dots \right); \quad y_2 = x^{-1/2} \left( 1 - \frac{3}{20}x + \frac{9}{352}x^2 - \frac{105}{23936}x^3 + \dots \right)$$

$$7.5.33 \text{ (p. 359)} \quad y_1 = x^{1/2} \sum_{m=0}^{\infty} \frac{(-1)^m}{8^m m!} \left( \prod_{j=1}^m \frac{4j-3}{8j+1} \right) x^{2m}; \quad y_2 = x^{1/4} \sum_{m=0}^{\infty} \frac{(-1)^m}{16^m m!} \left( \prod_{j=1}^m \frac{8j-7}{8j-1} \right) x^{2m}$$

$$7.5.34 \text{ (p. 359)} \quad y_1 = x^{1/2} \sum_{m=0}^{\infty} \left( \prod_{j=1}^m \frac{8j-3}{8j+1} \right) x^{2m}; \quad y_2 = x^{1/4} \sum_{m=0}^{\infty} \frac{1}{2^m m!} \left( \prod_{j=1}^m (2j-1) \right) x^{2m}$$

$$7.5.35 \text{ (p. 359)} \quad y_1 = x^4 \sum_{m=0}^{\infty} (-1)^m (m+1) x^{2m}; \quad y_2 = -x \sum_{m=0}^{\infty} (-1)^m (2m-1) x^{2m}$$

$$7.5.36 \text{ (p. 359)} \quad y_1 = x^{1/3} \sum_{m=0}^{\infty} \frac{(-1)^m}{18^m m!} \left( \prod_{j=1}^m (6j-17) \right) x^{2m}; \quad y_2 = 1 + \frac{4}{5}x^2 + \frac{8}{55}x^4$$

$$7.5.37 \text{ (p. 359)} \quad y_1 = x^{1/4} \sum_{m=0}^{\infty} \left( \prod_{j=1}^m \frac{8j+1}{8j+5} \right) x^{2m}; \quad y_2 = x^{-1} \sum_{m=0}^{\infty} \frac{\prod_{j=1}^m (2j-1)}{2^m m!} x^{2m}$$

$$7.5.38 \text{ (p. 359)} \quad y_1 = x^{1/2} \sum_{m=0}^{\infty} \frac{1}{8^m m!} \left( \prod_{j=1}^m (4j-1) \right) x^{2m}; \quad y_2 = x^{1/3} \sum_{m=0}^{\infty} 2^m \left( \prod_{j=1}^m \frac{3j-1}{12j-1} \right) x^{2m}$$

$$7.5.39 \text{ (p. 359)} \quad y_1 = x^{7/2} \sum_{m=0}^{\infty} (-1)^m \frac{\prod_{j=1}^m (4j+5)}{8^m m!} x^{2m}; \quad y_2 = x^{1/2} \sum_{m=0}^{\infty} \frac{(-1)^m}{4^m} \left( \prod_{j=1}^m \frac{4j-1}{2j-3} \right) x^{2m}$$



$$7.5.40 \text{ (p. 359)} \quad y_1 = x^{1/2} \sum_{m=0}^{\infty} \frac{(-1)^m}{4^m} \left( \prod_{j=1}^m \frac{4j-1}{2j+1} \right) x^{2m}; \quad y_2 = x^{-1/2} \sum_{m=0}^{\infty} \frac{(-1)^m}{8^m m!} \left( \prod_{j=1}^m (4j-3) \right) x^{2m}$$

$$7.5.41 \text{ (p. 359)} \quad y_1 = x^{1/2} \sum_{m=0}^{\infty} \frac{(-1)^m}{m!} \left( \prod_{j=1}^m (2j+1) \right) x^{2m}; \quad y_2 = \frac{1}{x^2} \sum_{m=0}^{\infty} (-2)^m \left( \prod_{j=1}^m \frac{4j-3}{4j-5} \right) x^{2m}$$

$$7.5.42 \text{ (p. 359)} \quad y_1 = x^{1/3} \sum_{m=0}^{\infty} (-1)^m \left( \prod_{j=1}^m \frac{3j-4}{3j+2} \right) x^{2m}; \quad y_2 = x^{-1}(1+x^2)$$

$$7.5.43 \text{ (p. 359)} \quad y_1 = \sum_{m=0}^{\infty} (-1)^m \frac{2^m(m+1)!}{\prod_{j=1}^m (2j+3)} x^{2m}; \quad y_2 = \frac{1}{x^3} \sum_{m=0}^{\infty} (-1)^m \frac{\prod_{j=1}^m (2j-1)}{2^m m!} x^{2m}$$

$$7.5.44 \text{ (p. 359)} \quad y_1 = x^{1/2} \sum_{m=0}^{\infty} \frac{(-1)^m}{8^m m!} \left( \prod_{j=1}^m \frac{(4j-3)^2}{4j+3} \right) x^{2m}; \quad y_2 = x^{-1} \sum_{m=0}^{\infty} \frac{(-1)^m}{2^m m!} \left( \prod_{j=1}^m \frac{(2j-3)^2}{4j-3} \right) x^{2m}$$

$$7.5.45 \text{ (p. 359)} \quad y_1 = x \sum_{m=0}^{\infty} (-2)^m \left( \prod_{j=1}^m \frac{2j+1}{4j+5} \right) x^{2m}; \quad y_2 = x^{-3/2} \sum_{m=0}^{\infty} \frac{(-1)^m}{4^m m!} \left( \prod_{j=1}^m (4j-3) \right) x^{2m}$$

$$7.5.46 \text{ (p. 359)} \quad y_1 = x^{1/3} \sum_{m=0}^{\infty} \frac{(-1)^m}{2^m \prod_{j=1}^m (3j+1)} x^{2m}; \quad y_2 = x^{-1/3} \sum_{m=0}^{\infty} \frac{(-1)^m}{6^m m!} x^{2m}$$

$$7.5.47 \text{ (p. 359)} \quad y_1 = x^{1/2} \left( 1 - \frac{6}{13}x^2 + \frac{36}{325}x^4 - \frac{216}{12025}x^6 + \dots \right); \quad y_2 = x^{1/3} \left( 1 - \frac{1}{2}x^2 + \frac{1}{8}x^4 - \frac{1}{48}x^6 + \dots \right)$$

$$7.5.48 \text{ (p. 359)} \quad y_1 = x^{1/4} \left( 1 - \frac{13}{64}x^2 + \frac{273}{8192}x^4 - \frac{2639}{524288}x^6 + \dots \right); \quad y_2 = x^{-1} \left( 1 - \frac{1}{3}x^2 + \frac{2}{33}x^4 - \frac{2}{209}x^6 + \dots \right)$$

$$7.5.49 \text{ (p. 359)} \quad y_1 = x^{1/3} \left( 1 - \frac{3}{4}x^2 + \frac{9}{14}x^4 - \frac{81}{140}x^6 + \dots \right); \quad y_2 = x^{-1/3} \left( 1 - \frac{2}{3}x^2 + \frac{5}{9}x^4 - \frac{40}{81}x^6 + \dots \right)$$

$$7.5.50 \text{ (p. 359)} \quad y_1 = x^{1/2} \left( 1 - \frac{3}{2}x^2 + \frac{15}{8}x^4 - \frac{35}{16}x^6 + \dots \right); \quad y_2 = x^{-1/2} \left( 1 - 2x^2 + \frac{8}{3}x^4 - \frac{16}{5}x^6 + \dots \right)$$

$$7.5.51 \text{ (p. 359)} \quad y_1 = x^{1/4} \left( 1 - x^2 + \frac{3}{2}x^4 - \frac{5}{2}x^6 + \dots \right); \quad y_2 = x^{-1/2} \left( 1 - \frac{2}{5}x^2 + \frac{36}{65}x^4 - \frac{408}{455}x^6 + \dots \right)$$

$$7.5.53 \text{ (p. 360)} \quad \text{(a)} \quad y_1 = x^\nu \sum_{m=0}^{\infty} \frac{(-1)^m}{4^m m! \prod_{j=1}^m (j+\nu)} x^{2m}; \quad y_2 = x^{-\nu} \sum_{m=0}^{\infty} \frac{(-1)^m}{4^m m! \prod_{j=1}^m (j-\nu)} x^{2m}$$

$$y_1 = \frac{\sin x}{\sqrt{x}}; \quad y_2 = \frac{\cos x}{\sqrt{x}}$$

$$7.5.61 \text{ (p. 363)} \quad y_1 = \frac{x^{1/2}}{1+x}; \quad y_2 = \frac{x}{1+x} \quad 7.5.62 \text{ (p. 364)} \quad y_1 = \frac{x^{1/3}}{1+2x^2}; \quad y_2 = \frac{x^{1/2}}{1+2x^2}$$

$$7.5.63 \text{ (p. 364)} \quad y_1 = \frac{x^{1/4}}{1-3x}; \quad y_2 = \frac{x^2}{1-3x} \quad 7.5.64 \text{ (p. 364)} \quad y_1 = \frac{x^{1/3}}{5+x}; \quad y_2 = \frac{x^{-1/3}}{5+x}$$

$$7.5.65 \text{ (p. 364)} \quad y_1 = \frac{x^{1/4}}{2-x^2}; \quad y_2 = \frac{x^{-1/2}}{2-x^2} \quad 7.5.66 \text{ (p. 364)} \quad y_1 = \frac{x^{1/2}}{1+3x+x^2}; \quad y_2 = \frac{x^{3/2}}{1+3x+x^2}$$

$$7.5.67 \text{ (p. 364)} \quad y_1 = \frac{x}{(1+x)^2}; \quad y_2 = \frac{x^{1/3}}{(1+x)^2} \quad 7.5.68 \text{ (p. 364)} \quad y_1 = \frac{x}{3+2x+x^2}; \quad y_2 = \frac{x^{1/4}}{3+2x+x^2}$$

**Section 7.6 Answers, pp. 373–378**

$$7.6.1 \text{ (p. 373)} \quad y_1 = x \left( 1 - x + \frac{3}{4}x^2 - \frac{13}{36}x^3 + \dots \right); \quad y_2 = y_1 \ln x + x^2 \left( 1 - x + \frac{65}{108}x^2 + \dots \right)$$

$$7.6.2 \text{ (p. 373)} \quad y_1 = x^{-1} \left( 1 - 2x + \frac{9}{2}x^2 - \frac{20}{3}x^3 + \dots \right); \quad y_2 = y_1 \ln x + 1 - \frac{15}{4}x + \frac{133}{18}x^2 + \dots$$

$$7.6.3 \text{ (p. 373)} \quad y_1 = 1 + x - x^2 + \frac{1}{3}x^3 + \dots; \quad y_2 = y_1 \ln x - x \left( 3 - \frac{1}{2}x - \frac{31}{18}x^2 + \dots \right)$$

$$7.6.4 \text{ (p. 373)} \quad y_1 = x^{1/2} \left( 1 - 2x + \frac{5}{2}x^2 - 2x^3 + \cdots \right); \quad y_2 = y_1 \ln x + x^{3/2} \left( 1 - \frac{9}{4}x + \frac{17}{6}x^2 + \cdots \right)$$

$$7.6.5 \text{ (p. 373)} \quad y_1 = x \left( 1 - 4x + \frac{19}{2}x^2 - \frac{49}{3}x^3 + \cdots \right); \quad y_2 = y_1 \ln x + x^2 \left( 3 - \frac{43}{4}x + \frac{208}{9}x^2 + \cdots \right)$$

$$7.6.6 \text{ (p. 373)} \quad y_1 = x^{-1/3} \left( 1 - x + \frac{5}{6}x^2 - \frac{1}{2}x^3 + \cdots \right); \quad y_2 = y_1 \ln x + x^{2/3} \left( 1 - \frac{11}{12}x + \frac{25}{36}x^2 + \cdots \right)$$

$$7.6.7 \text{ (p. 373)} \quad y_1 = 1 - 2x + \frac{7}{4}x^2 - \frac{7}{9}x^3 + \cdots; \quad y_2 = y_1 \ln x + x \left( 3 - \frac{15}{4}x + \frac{239}{108}x^2 + \cdots \right)$$

$$7.6.8 \text{ (p. 373)} \quad y_1 = x^{-2} \left( 1 - 2x + \frac{5}{2}x^2 - 3x^3 + \cdots \right); \quad y_2 = y_1 \ln x + \frac{3}{4} - \frac{13}{6}x + \cdots$$

$$7.6.9 \text{ (p. 373)} \quad y_1 = x^{-1/2} \left( 1 - x + \frac{1}{4}x^2 + \frac{1}{18}x^3 + \cdots \right); \quad y_2 = y_1 \ln x + x^{1/2} \left( \frac{3}{2} - \frac{13}{16}x + \frac{1}{54}x^2 + \cdots \right)$$

$$7.6.10 \text{ (p. 373)} \quad y_1 = x^{-1/4} \left( 1 - \frac{1}{4}x - \frac{7}{32}x^2 + \frac{23}{384}x^3 + \cdots \right); \quad y_2 = y_1 \ln x + x^{3/4} \left( \frac{1}{4} + \frac{5}{64}x - \frac{157}{2304}x^2 + \cdots \right)$$

$$7.6.11 \text{ (p. 373)} \quad y_1 = x^{-1/3} \left( 1 - x + \frac{7}{6}x^2 - \frac{23}{18}x^3 + \cdots \right); \quad y_2 = y_1 \ln x - x^{5/3} \left( \frac{1}{12} - \frac{13}{108}x + \cdots \right)$$

$$7.6.12 \text{ (p. 373)} \quad y_1 = x^{1/2} \sum_{n=0}^{\infty} \frac{(-1)^n}{(n!)^2} x^n; \quad y_2 = y_1 \ln x - 2x^{1/2} \sum_{n=1}^{\infty} \frac{(-1)^n}{(n!)^2} \left( \sum_{j=1}^n \frac{1}{j} \right) x^n;$$

$$7.6.13 \text{ (p. 374)} \quad y_1 = x^{1/6} \sum_{n=0}^{\infty} \left( \frac{2}{3} \right)^n \frac{\prod_{j=1}^n (3j+1)}{n!} x^n;$$

$$y_2 = y_1 \ln x - x^{1/6} \sum_{n=1}^{\infty} \left( \frac{2}{3} \right)^n \frac{\prod_{j=1}^n (3j+1)}{n!} \left( \sum_{j=1}^n \frac{1}{j(3j+1)} \right) x^n$$

$$7.6.14 \text{ (p. 374)} \quad y_1 = x^2 \sum_{n=0}^{\infty} (-1)^n (n+1)^2 x^n; \quad y_2 = y_1 \ln x - 2x^2 \sum_{n=1}^{\infty} (-1)^n n(n+1) x^n$$

$$7.6.15 \text{ (p. 374)} \quad y_1 = x^3 \sum_{n=0}^{\infty} 2^n (n+1) x^n; \quad y_2 = y_1 \ln x - x^3 \sum_{n=1}^{\infty} 2^n n x^n$$

$$7.6.16 \text{ (p. 374)} \quad y_1 = x^{1/5} \sum_{n=0}^{\infty} \frac{(-1)^n \prod_{j=1}^n (5j+1)}{125^n (n!)^2} x^n;$$

$$y_2 = y_1 \ln x - x^{1/5} \sum_{n=1}^{\infty} \frac{(-1)^n \prod_{j=1}^n (5j+1)}{125^n (n!)^2} \left( \sum_{j=1}^n \frac{5j+2}{j(5j+1)} \right) x^n$$

$$7.6.17 \text{ (p. 374)} \quad y_1 = x^{1/2} \sum_{n=0}^{\infty} \frac{(-1)^n \prod_{j=1}^n (2j-3)}{4^n n!} x^n;$$

$$y_2 = y_1 \ln x + 3x^{1/2} \sum_{n=1}^{\infty} \frac{(-1)^n \prod_{j=1}^n (2j-3)}{4^n n!} \left( \sum_{j=1}^n \frac{1}{j(2j-3)} \right) x^n$$

$$7.6.18 \text{ (p. 374)} \quad y_1 = x^{1/3} \sum_{n=0}^{\infty} \frac{(-1)^n \prod_{j=1}^n (6j-7)^2}{81^n (n!)^2} x^n;$$

$$y_2 = y_1 \ln x + 14x^{1/3} \sum_{n=1}^{\infty} \frac{(-1)^n \prod_{j=1}^n (6j-7)^2}{81^n (n!)^2} \left( \sum_{j=1}^n \frac{1}{j(6j-7)} \right) x^n$$

$$7.6.19 \text{ (p. 374)} \quad y_1 = x^2 \sum_{n=0}^{\infty} \frac{(-1)^n \prod_{j=1}^n (2j+5)}{(n!)^2} x^n;$$

$$y_2 = y_1 \ln x - 2x^2 \sum_{n=1}^{\infty} \frac{(-1)^n \prod_{j=1}^n (2j+5)}{(n!)^2} \left( \sum_{j=1}^n \frac{(j+5)}{j(2j+5)} \right) x^n$$

$$7.6.20 \text{ (p. 374)} \quad y_1 = \frac{1}{x} \sum_{n=0}^{\infty} \frac{2^n \prod_{j=1}^n (2j-1)}{n!} x^n;$$

$$y_2 = y_1 \ln x + \frac{1}{x} \sum_{n=1}^{\infty} \frac{2^n \prod_{j=1}^n (2j-1)}{n!} \left( \sum_{j=1}^n \frac{1}{j(2j-1)} \right) x^n$$

$$7.6.21 \text{ (p. 374)} \quad y_1 = \frac{1}{x} \sum_{n=0}^{\infty} \frac{(-1)^n \prod_{j=1}^n (2j-5)}{n!} x^n;$$

$$y_2 = y_1 \ln x + \frac{5}{x} \sum_{n=1}^{\infty} \frac{(-1)^n \prod_{j=1}^n (2j-5)}{n!} \left( \sum_{j=1}^n \frac{1}{j(2j-5)} \right) x^n$$

$$7.6.22 \text{ (p. 374)} \quad y_1 = x^2 \sum_{n=0}^{\infty} \frac{(-1)^n \prod_{j=1}^n (2j+3)}{2^n n!} x^n;$$

$$y_2 = y_1 \ln x - 3x^2 \sum_{n=0}^{\infty} \frac{(-1)^n \prod_{j=1}^n (2j+3)}{2^n n!} \left( \sum_{j=1}^n \frac{1}{j(2j+3)} \right) x^n$$

$$7.6.23 \text{ (p. 374)} \quad y_1 = x^{-2} \left( 1 + 3x + \frac{3}{2}x^2 - \frac{1}{2}x^3 + \cdots \right); \quad y_2 = y_1 \ln x - 5x^{-1} \left( 1 + \frac{5}{4}x - \frac{1}{4}x^2 + \cdots \right)$$

$$7.6.24 \text{ (p. 374)} \quad y_1 = x^3(1 + 20x + 180x^2 + 1120x^3 + \cdots); \quad y_2 = y_1 \ln x - x^4 \left( 26 + 324x + \frac{6968}{3}x^2 + \cdots \right)$$

$$7.6.25 \text{ (p. 374)} \quad y_1 = x \left( 1 - 5x + \frac{85}{4}x^2 - \frac{3145}{36}x^3 + \cdots \right); \quad y_2 = y_1 \ln x + x^2 \left( 2 - \frac{39}{4}x + \frac{4499}{108}x^2 + \cdots \right)$$

$$7.6.26 \text{ (p. 374)} \quad y_1 = 1 - x + \frac{3}{4}x^2 - \frac{7}{12}x^3 + \cdots; \quad y_2 = y_1 \ln x + x \left( 1 - \frac{3}{4}x + \frac{5}{9}x^2 + \cdots \right)$$

$$7.6.27 \text{ (p. 374)} \quad y_1 = x^{-3}(1 + 16x + 36x^2 + 16x^3 + \cdots); \quad y_2 = y_1 \ln x - x^{-2} \left( 40 + 150x + \frac{280}{3}x^2 + \cdots \right)$$

$$7.6.28 \text{ (p. 374)} \quad y_1 = x \sum_{m=0}^{\infty} \frac{(-1)^m}{2^m m!} x^{2m}; \quad y_2 = y_1 \ln x - \frac{x}{2} \sum_{m=1}^{\infty} \frac{(-1)^m}{2^m m!} \left( \sum_{j=1}^m \frac{1}{j} \right) x^{2m}$$

$$7.6.29 \text{ (p. 374)} \quad y_1 = x^2 \sum_{m=0}^{\infty} (-1)^m (m+1) x^{2m}; \quad y_2 = y_1 \ln x - \frac{x^2}{2} \sum_{m=1}^{\infty} (-1)^m m x^{2m}$$

$$7.6.30 \text{ (p. 374)} \quad y_1 = x^{1/2} \sum_{m=0}^{\infty} \frac{(-1)^m}{4^m m!} x^{2m}; \quad y_2 = y_1 \ln x - \frac{x^{1/2}}{2} \sum_{m=1}^{\infty} \frac{(-1)^m}{4^m m!} \left( \sum_{j=1}^m \frac{1}{j} \right) x^{2m}$$

$$7.6.31 \text{ (p. 374)} \quad y_1 = x \sum_{m=0}^{\infty} \frac{(-1)^m \prod_{j=1}^m (2j-1)}{2^m m!} x^{2m};$$

$$y_2 = y_1 \ln x + \frac{x}{2} \sum_{m=1}^{\infty} \frac{(-1)^m \prod_{j=1}^m (2j-1)}{2^m m!} \left( \sum_{j=1}^m \frac{1}{j(2j-1)} \right) x^{2m}$$

$$7.6.32 \text{ (p. 374)} \quad y_1 = x^{1/2} \sum_{m=0}^{\infty} \frac{(-1)^m \prod_{j=1}^m (4j-1)}{8^m m!} x^{2m};$$

$$y_2 = y_1 \ln x + \frac{x^{1/2}}{2} \sum_{m=1}^{\infty} \frac{(-1)^m \prod_{j=1}^m (4j-1)}{8^m m!} \left( \sum_{j=1}^m \frac{1}{j(4j-1)} \right) x^{2m}$$

$$7.6.33 \text{ (p. 374)} \quad y_1 = x \sum_{m=0}^{\infty} \frac{(-1)^m \prod_{j=1}^m (2j+1)}{2^m m!} x^{2m};$$

$$y_2 = y_1 \ln x - \frac{x}{2} \sum_{m=1}^{\infty} \frac{(-1)^m \prod_{j=1}^m (2j+1)}{2^m m!} \left( \sum_{j=1}^m \frac{1}{j(2j+1)} \right) x^{2m}$$

$$7.6.34 \text{ (p. 374)} \quad y_1 = x^{-1/4} \sum_{m=0}^{\infty} \frac{(-1)^m \prod_{j=1}^m (8j-13)}{(32)^m m!} x^{2m};$$

$$y_2 = y_1 \ln x + \frac{13}{2} x^{-1/4} \sum_{m=1}^{\infty} \frac{(-1)^m \prod_{j=1}^m (8j-13)}{(32)^m m!} \left( \sum_{j=1}^m \frac{1}{j(8j-13)} \right) x^{2m}$$

$$7.6.35 \text{ (p. 374)} \quad y_1 = x^{1/3} \sum_{m=0}^{\infty} \frac{(-1)^m \prod_{j=1}^m (3j-1)}{9^m m!} x^{2m};$$

$$y_2 = y_1 \ln x + \frac{x^{1/3}}{2} \sum_{m=1}^{\infty} \frac{(-1)^m \prod_{j=1}^m (3j-1)}{9^m m!} \left( \sum_{j=1}^m \frac{1}{j(3j-1)} \right) x^{2m}$$

$$7.6.36 \text{ (p. 374)} \quad y_1 = x^{1/2} \sum_{m=0}^{\infty} \frac{(-1)^m \prod_{j=1}^m (4j-3)(4j-1)}{4^m (m!)^2} x^{2m};$$

$$y_2 = y_1 \ln x + x^{1/2} \sum_{m=1}^{\infty} \frac{(-1)^m \prod_{j=1}^m (4j-3)(4j-1)}{4^m (m!)^2} \left( \sum_{j=1}^m \frac{8j-3}{j(4j-3)(4j-1)} \right) x^{2m}$$

$$7.6.37 \text{ (p. 374)} \quad y_1 = x^{5/3} \sum_{m=0}^{\infty} \frac{(-1)^m}{3^m m!} x^{2m}; \quad y_2 = y_1 \ln x - \frac{x^{5/3}}{2} \sum_{m=1}^{\infty} \frac{(-1)^m}{3^m m!} \left( \sum_{j=1}^m \frac{1}{j} \right) x^{2m}$$

$$7.6.38 \text{ (p. 374)} \quad y_1 = \frac{1}{x} \sum_{m=0}^{\infty} \frac{(-1)^m \prod_{j=1}^m (4j-7)}{2^m m!} x^{2m};$$

$$y_2 = y_1 \ln x + \frac{7}{2x} \sum_{m=1}^{\infty} \frac{(-1)^m \prod_{j=1}^m (4j-7)}{2^m m!} \left( \sum_{j=1}^m \frac{1}{j(4j-7)} \right) x^{2m}$$

$$7.6.39 \text{ (p. 374)} \quad y_1 = x^{-1} \left( 1 - \frac{3}{2}x^2 + \frac{15}{8}x^4 - \frac{35}{16}x^6 + \dots \right)$$

$$; \quad y_2 = y_1 \ln x + x \left( \frac{1}{4} - \frac{13}{32}x^2 + \frac{101}{192}x^4 + \dots \right)$$

$$7.6.40 \text{ (p. 375)} \quad y_1 = x \left( 1 - \frac{1}{2}x^2 + \frac{1}{8}x^4 - \frac{1}{48}x^6 + \dots \right); \quad y_2 = y_1 \ln x + x^3 \left( \frac{1}{4} - \frac{3}{32}x^2 + \frac{11}{576}x^4 + \dots \right)$$

$$7.6.41 \text{ (p. 375)} \quad y_1 = x^{-2} \left( 1 - \frac{3}{4}x^2 - \frac{9}{64}x^4 - \frac{25}{256}x^6 + \dots \right); \quad y_2 = y_1 \ln x + \frac{1}{2} - \frac{21}{128}x^2 - \frac{215}{1536}x^4 + \dots$$

$$7.6.42 \text{ (p. 375)} \quad y_1 = x^{-3} \left( 1 - \frac{17}{8}x^2 + \frac{85}{256}x^4 - \frac{85}{18432}x^6 + \dots \right); \quad y_2 = y_1 \ln x + x^{-1} \left( \frac{25}{8} - \frac{471}{512}x^2 + \frac{1583}{110592}x^4 + \dots \right)$$

$$7.6.43 \text{ (p. 375)} \quad y_1 = x^{-1} \left( 1 - \frac{3}{4}x^2 + \frac{45}{64}x^4 - \frac{175}{256}x^6 + \dots \right); \quad y_2 = y_1 \ln x - x \left( \frac{1}{4} - \frac{33}{128}x^2 + \frac{395}{1536}x^4 + \dots \right)$$

$$7.6.44 \text{ (p. 375)} \quad y_1 = \frac{1}{x}; \quad y_2 = y_1 \ln x - 6 + 6x - \frac{8}{3}x^2$$

$$7.6.45 \text{ (p. 375)} \quad y_1 = 1 - x; \quad y_2 = y_1 \ln x + 4x$$

$$7.6.46 \text{ (p. 375)} \quad y_1 = \frac{(x-1)^2}{x}; \quad y_2 = y_1 \ln x + 3 - 3x + 2 \sum_{n=2}^{\infty} \frac{1}{n(n^2-1)} x^n$$

$$7.6.47 \text{ (p. 375)} \quad y_1 = x^{1/2}(x+1)^2; \quad y_2 = y_1 \ln x - x^{3/2} \left( 3 + 3x + 2 \sum_{n=2}^{\infty} \frac{(-1)^n}{n(n^2-1)} x^n \right)$$

$$7.6.48 \text{ (p. 375)} \quad y_1 = x^2(1-x)^3; \quad y_2 = y_1 \ln x + x^3 \left( 4 - 7x + \frac{11}{3}x^2 - 6 \sum_{n=3}^{\infty} \frac{1}{n(n-2)(n^2-1)} x^n \right)$$

$$7.6.49 \text{ (p. 375)} \quad y_1 = x - 4x^3 + x^5; \quad y_2 = y_1 \ln x + 6x^3 - 3x^5$$

$$7.6.50 \text{ (p. 375)} \quad y_1 = x^{1/3} \left( 1 - \frac{1}{6}x^2 \right); \quad y_2 = y_1 \ln x + x^{7/3} \left( \frac{1}{4} - \frac{1}{12} \sum_{m=1}^{\infty} \frac{1}{6^m m(m+1)(m+1)!} x^{2m} \right)$$

$$7.6.51 \text{ (p. 375)} \quad y_1 = (1 + x^2)^2; \quad y_2 = y_1 \ln x - \frac{3}{2}x^2 - \frac{3}{2}x^4 + \sum_{m=3}^{\infty} \frac{(-1)^m}{m(m-1)(m-2)} x^{2m}$$

$$7.6.52 \text{ (p. 375)} \quad y_1 = x^{-1/2} \left( 1 - \frac{1}{2}x^2 + \frac{1}{32}x^4 \right); \quad y_2 = y_1 \ln x + x^{3/2} \left( \frac{5}{8} - \frac{9}{128}x^2 + \sum_{m=2}^{\infty} \frac{1}{4^{m+1}(m-1)m(m+1)(m+1)!} x^{2m} \right).$$

$$7.6.56 \text{ (p. 377)} \quad y_1 = \sum_{m=0}^{\infty} \frac{(-1)^m}{4^m(m!)^2} x^{2m}; \quad y_2 = y_1 \ln x - \sum_{m=1}^{\infty} \frac{(-1)^m}{4^m(m!)^2} \left( \sum_{j=1}^m \frac{1}{j} \right) x^{2m}$$

$$7.6.58 \text{ (p. 378)} \quad \frac{x^{1/2}}{1+x}; \quad \frac{x^{1/2} \ln x}{1+x} \quad 7.6.59 \text{ (p. 378)} \quad \frac{x^{1/3}}{3+x}; \quad \frac{x^{1/3} \ln x}{3+x}$$

$$7.6.60 \text{ (p. 378)} \quad \frac{x}{2-x^2}; \quad \frac{x \ln x}{2-x^2} \quad 7.6.61 \text{ (p. 378)} \quad \frac{x^{1/4}}{1+x^2}; \quad \frac{x^{1/4} \ln x}{1+x^2}$$

$$7.6.62 \text{ (p. 378)} \quad \frac{x}{4+3x}; \quad \frac{x \ln x}{4+3x} \quad 7.6.63 \text{ (p. 378)} \quad \frac{x^{1/2}}{1+3x+x^2}; \quad \frac{x^{1/2} \ln x}{1+3x+x^2}$$

$$7.6.64 \text{ (p. 378)} \quad \frac{x}{(1-x)^2}; \quad \frac{x \ln x}{(1-x)^2} \quad 7.6.65 \text{ (p. 378)} \quad \frac{x^{1/3}}{1+x+x^2}; \quad \frac{x^{1/3} \ln x}{1+x+x^2}$$

## Section 7.7 Answers, pp. 388–390

$$7.7.1 \text{ (p. 388)} \quad y_1 = 2x^3 \sum_{n=0}^{\infty} \frac{(-4)^n}{n!(n+2)!} x^n; \quad y_2 = x + 4x^2 - 8 \left( y_1 \ln x - 4 \sum_{n=1}^{\infty} \frac{(-4)^n}{n!(n+2)!} \left( \sum_{j=1}^n \frac{j+1}{j(j+2)} \right) x^n \right)$$

$$7.7.2 \text{ (p. 388)} \quad y_1 = x \sum_{n=0}^{\infty} \frac{(-1)^n}{n!(n+1)!} x^n; \quad y_2 = 1 - y_1 \ln x + x \sum_{n=1}^{\infty} \frac{(-1)^n}{n!(n+1)!} \left( \sum_{j=1}^n \frac{2j+1}{j(j+1)} \right) x^n$$

$$7.7.3 \text{ (p. 388)} \quad y_1 = x^{1/2}; \quad y_2 = x^{-1/2} + y_1 \ln x + x^{1/2} \sum_{n=1}^{\infty} \frac{(-1)^n}{n} x^n$$

$$7.7.4 \text{ (p. 388)} \quad y_1 = x \sum_{n=0}^{\infty} \frac{(-1)^n}{n!} x^n = xe^{-x}; \quad y_2 = 1 - y_1 \ln x + x \sum_{n=1}^{\infty} \frac{(-1)^n}{n!} \left( \sum_{j=1}^n \frac{1}{j} \right) x^n$$

$$7.7.5 \text{ (p. 388)} \quad y_1 = x^{1/2} \sum_{n=0}^{\infty} \left( -\frac{3}{4} \right)^n \frac{\prod_{j=1}^n (2j+1)}{n!} x^n;$$

$$y_2 = x^{-1/2} - \frac{3}{4} \left( y_1 \ln x - x^{1/2} \sum_{n=1}^{\infty} \left( -\frac{3}{4} \right)^n \frac{\prod_{j=1}^n (2j+1)}{n!} \left( \sum_{j=1}^n \frac{1}{j(2j+1)} \right) x^n \right)$$

$$7.7.6 \text{ (p. 388)} \quad y_1 = x \sum_{n=0}^{\infty} \frac{(-1)^n}{n!} x^n = xe^{-x}; \quad y_2 = x^{-2} \left( 1 + \frac{1}{2}x + \frac{1}{2}x^2 \right) - \frac{1}{2} \left( y_1 \ln x - x \sum_{n=1}^{\infty} \frac{(-1)^n}{n!} \left( \sum_{j=1}^n \frac{1}{j} \right) x^n \right)$$

$$7.7.7 \text{ (p. 388)} \quad y_1 = 6x^{3/2} \sum_{n=0}^{\infty} \frac{(-1)^n}{4^n n!(n+3)!} x^n;$$

$$y_2 = x^{-3/2} \left( 1 + \frac{1}{8}x + \frac{1}{64}x^2 \right) - \frac{1}{768} \left( y_1 \ln x - 6x^{3/2} \sum_{n=1}^{\infty} \frac{(-1)^n}{4^n n!(n+3)!} \left( \sum_{j=1}^n \frac{2j+3}{j(j+3)} \right) x^n \right)$$

$$7.7.8 \text{ (p. 388)} \quad y_1 = \frac{120}{x^2} \sum_{n=0}^{\infty} \frac{(-1)^n}{n!(n+5)!} x^n;$$

$$y_2 = x^{-7} \left( 1 + \frac{1}{4}x + \frac{1}{24}x^2 + \frac{1}{144}x^3 + \frac{1}{576}x^4 \right) - \frac{1}{2880} \left( y_1 \ln x - \frac{120}{x^2} \sum_{n=1}^{\infty} \frac{(-1)^n}{n!(n+5)!} \left( \sum_{j=1}^n \frac{2j+5}{j(j+5)} \right) x^n \right)$$

$$7.7.9 \text{ (p. 388)} \quad y_1 = \frac{x^{1/2}}{6} \sum_{n=0}^{\infty} (-1)^n (n+1)(n+2)(n+3) x^n;$$

$$y_2 = x^{-5/2} \left( 1 + \frac{1}{2}x + x^2 \right) - 3y_1 \ln x + \frac{3}{2}x^{1/2} \sum_{n=1}^{\infty} (-1)^n (n+1)(n+2)(n+3) \left( \sum_{j=1}^n \frac{1}{j(j+3)} \right) x^n$$

$$7.7.10 \text{ (p. 388)} \quad y_1 = x^4 \left( 1 - \frac{2}{5}x \right) \quad y_2 = 1 + 10x + 50x^2 + 200x^3 - 300 \left( y_1 \ln x + \frac{27}{25}x^5 - \frac{1}{30}x^6 \right)$$

$$7.7.11 \text{ (p. 388)} \quad y_1 = x^3; \quad y_2 = x^{-3} \left( 1 - \frac{6}{5}x + \frac{3}{4}x^2 - \frac{1}{3}x^3 + \frac{1}{8}x^4 - \frac{1}{20}x^5 \right) - \frac{1}{120} \left( y_1 \ln x + x^3 \sum_{n=1}^{\infty} \frac{(-1)^n 6!}{n(n+6)!} x^n \right)$$

$$7.7.12 \text{ (p. 388)} \quad y_1 = x^2 \sum_{n=0}^{\infty} \frac{1}{n!} \left( \prod_{j=1}^n \frac{2j+3}{j+4} \right) x^n;$$

$$y_2 = x^{-2} \left( 1 + x + \frac{1}{4}x^2 - \frac{1}{12}x^3 \right) - \frac{1}{16}y_1 \ln x + \frac{x^2}{8} \sum_{n=1}^{\infty} \frac{1}{n!} \left( \prod_{j=1}^n \frac{2j+3}{j+4} \right) \left( \sum_{j=1}^n \frac{(j^2+3j+6)}{j(j+4)(2j+3)} \right) x^n$$

$$7.7.13 \text{ (p. 388)} \quad y_1 = x^5 \sum_{n=0}^{\infty} (-1)^n (n+1)(n+2)x^n; \quad y_2 = 1 - \frac{x}{2} + \frac{x^2}{6}$$

$$7.7.14 \text{ (p. 388)} \quad y_1 = \frac{1}{x} \sum_{n=0}^{\infty} \frac{(-1)^n}{n!} \left( \prod_{j=1}^n \frac{(j+3)(2j-3)}{j+6} \right) x^n; \quad y_2 = x^{-7} \left( 1 + \frac{26}{5}x + \frac{143}{20}x^2 \right)$$

$$7.7.15 \text{ (p. 388)} \quad y_1 = x^{7/2} \sum_{n=0}^{\infty} \frac{(-1)^n}{2^n(n+4)!} x^n; \quad y_2 = x^{-1/2} \left( 1 - \frac{1}{2}x + \frac{1}{8}x^2 - \frac{1}{48}x^3 \right)$$

$$7.7.16 \text{ (p. 388)} \quad y_1 = x^{10/3} \sum_{n=0}^{\infty} \frac{(-1)^n(n+1)}{9^n} \left( \prod_{j=1}^n \frac{3j+7}{j+4} \right) x^n; \quad y_2 = x^{-2/3} \left( 1 + \frac{4}{27}x - \frac{1}{243}x^2 \right)$$

$$7.7.17 \text{ (p. 388)} \quad y_1 = x^3 \sum_{n=0}^7 (-1)^n (n+1) \left( \prod_{j=1}^n \frac{j-8}{j+6} \right) x^n; \quad y_2 = x^{-3} \left( 1 + \frac{52}{5}x + \frac{234}{5}x^2 + \frac{572}{5}x^3 + 143x^4 \right)$$

$$7.7.18 \text{ (p. 388)} \quad y_1 = x^3 \sum_{n=0}^{\infty} \frac{(-1)^n}{n!} \left( \prod_{j=1}^n \frac{(j+3)^2}{j+5} \right) x^n; \quad y_2 = x^{-2} \left( 1 + \frac{1}{4}x \right)$$

$$7.7.19 \text{ (p. 388)} \quad y_1 = x^6 \sum_{n=0}^4 (-1)^n 2^n \left( \prod_{j=1}^n \frac{j-5}{j+5} \right) x^n; \quad y_2 = x(1 + 18x + 144x^2 + 672x^3 + 2016x^4)$$

$$7.7.20 \text{ (p. 388)} \quad y_1 = x^6 \left( 1 + \frac{2}{3}x + \frac{1}{7}x^2 \right); \quad y_2 = x \left( 1 + \frac{21}{4}x + \frac{21}{2}x^2 + \frac{35}{4}x^3 \right)$$

$$7.7.21 \text{ (p. 388)} \quad y_1 = x^{7/2} \sum_{n=0}^{\infty} (-1)^n (n+1)x^n; \quad y_2 = x^{-7/2} \left( 1 - \frac{5}{6}x + \frac{2}{3}x^2 - \frac{1}{2}x^3 + \frac{1}{3}x^4 - \frac{1}{6}x^5 \right)$$

$$7.7.22 \text{ (p. 388)} \quad y_1 = \frac{x^{10}}{6} \sum_{n=0}^{\infty} (-1)^n 2^n (n+1)(n+2)(n+3)x^n;$$

$$y_2 = \left( 1 - \frac{4}{3}x + \frac{5}{3}x^2 - \frac{40}{21}x^3 + \frac{40}{21}x^4 - \frac{32}{21}x^5 + \frac{16}{21}x^6 \right)$$

$$7.7.23 \text{ (p. 388)} \quad y_1 = x^6 \sum_{m=0}^{\infty} \frac{(-1)^m \prod_{j=1}^m (2j+5)}{2^m m!} x^{2m};$$

$$y_2 = x^2 \left( 1 + \frac{3}{2}x^2 \right) - \frac{15}{2}y_1 \ln x + \frac{75}{2}x^6 \sum_{m=1}^{\infty} \frac{(-1)^m \prod_{j=1}^m (2j+5)}{2^{m+1} m!} \left( \sum_{j=1}^m \frac{1}{j(2j+5)} \right) x^{2m}$$

$$7.7.24 \text{ (p. 388)} \quad y_1 = x^6 \sum_{m=0}^{\infty} \frac{(-1)^m}{2^m m!} x^{2m} = x^6 e^{-x^2/2};$$

$$y_2 = x^2 \left( 1 + \frac{1}{2}x^2 \right) - \frac{1}{2}y_1 \ln x + \frac{x^6}{4} \sum_{m=1}^{\infty} \frac{(-1)^m}{2^m m!} \left( \sum_{j=1}^m \frac{1}{j} \right) x^{2m}$$

$$7.7.25 \text{ (p. 388)} \quad y_1 = 6x^6 \sum_{m=0}^{\infty} \frac{(-1)^m}{4^m m!(m+3)!} x^{2m};$$

$$y_2 = 1 + \frac{1}{8}x^2 + \frac{1}{64}x^4 - \frac{1}{384} \left( y_1 \ln x - 3x^6 \sum_{m=1}^{\infty} \frac{(-1)^m}{4^m m!(m+3)!} \left( \sum_{j=1}^m \frac{2j+3}{j(j+3)} \right) x^{2m} \right)$$

$$7.7.26 \text{ (p. 388)} \quad y_1 = \frac{x}{2} \sum_{m=0}^{\infty} \frac{(-1)^m (m+2)}{m!} x^{2m};$$

$$y_2 = x^{-1} - 4y_1 \ln x + x \sum_{m=1}^{\infty} \frac{(-1)^m (m+2)}{m!} \left( \sum_{j=1}^m \frac{j^2 + 4j + 2}{j(j+1)(j+2)} \right) x^{2m}$$

$$7.7.27 \text{ (p. 388)} \quad y_1 = 2x^3 \sum_{m=0}^{\infty} \frac{(-1)^m}{4^m m!(m+2)!} x^{2m};$$

$$y_2 = x^{-1} \left( 1 + \frac{1}{4} x^2 \right) - \frac{1}{16} \left( y_1 \ln x - 2x^3 \sum_{m=1}^{\infty} \frac{(-1)^m}{4^m m!(m+2)!} \left( \sum_{j=1}^m \frac{j+1}{j(j+2)} \right) x^{2m} \right)$$

$$7.7.28 \text{ (p. 388)} \quad y_1 = x^{-1/2} \sum_{m=0}^{\infty} \frac{(-1)^m \prod_{j=1}^m (2j-1)}{8^m m!(m+1)!} x^{2m};$$

$$y_2 = x^{-5/2} + \frac{1}{4} y_1 \ln x - x^{-1/2} \sum_{m=1}^{\infty} \frac{(-1)^m \prod_{j=1}^m (2j-1)}{8^{m+1} m!(m+1)!} \left( \sum_{j=1}^m \frac{2j^2 - 2j - 1}{j(j+1)(2j-1)} \right) x^{2m}$$

$$7.7.29 \text{ (p. 388)} \quad y_1 = x \sum_{m=0}^{\infty} \frac{(-1)^m}{2^m m!} x^{2m} = x e^{-x^2/2}; \quad y_2 = x^{-1} - y_1 \ln x + \frac{x}{2} \sum_{m=1}^{\infty} \frac{(-1)^m}{2^m m!} \left( \sum_{j=1}^m \frac{1}{j} \right) x^{2m}$$

$$7.7.30 \text{ (p. 388)} \quad y_1 = x^2 \sum_{m=0}^{\infty} \frac{1}{m!} x^{2m} = x^2 e^{x^2}; \quad y_2 = x^{-2}(1-x^2) - 2y_1 \ln x + x^2 \sum_{m=1}^{\infty} \frac{1}{m!} \left( \sum_{j=1}^m \frac{1}{j} \right) x^{2m}$$

$$7.7.31 \text{ (p. 388)} \quad y_1 = 6x^{5/2} \sum_{m=0}^{\infty} \frac{(-1)^m}{16^m m!(m+3)!} x^{2m};$$

$$y_2 = x^{-7/2} \left( 1 + \frac{1}{32} x^2 + \frac{1}{1024} x^4 \right) - \frac{1}{24576} \left( y_1 \ln x - 3x^{5/2} \sum_{m=1}^{\infty} \frac{(-1)^m}{16^m m!(m+3)!} \left( \sum_{j=1}^m \frac{2j+3}{j(j+3)} \right) x^{2m} \right)$$

$$7.7.32 \text{ (p. 388)} \quad y_1 = 2x^{13/3} \sum_{m=0}^{\infty} \frac{\prod_{j=1}^m (3j+1)}{9^m m!(m+2)!} x^{2m};$$

$$y_2 = x^{1/3} \left( 1 + \frac{2}{9} x^2 \right) + \frac{2}{81} \left( y_1 \ln x - x^{13/3} \sum_{m=0}^{\infty} \frac{\prod_{j=1}^m (3j+1)}{9^m m!(m+2)!} \left( \sum_{j=1}^m \frac{3j^2 + 2j + 2}{j(j+2)(3j+1)} \right) x^{2m} \right)$$

$$7.7.33 \text{ (p. 388)} \quad y_1 = x^2; \quad y_2 = x^{-2}(1+2x^2) - 2 \left( y_1 \ln x + x^2 \sum_{m=1}^{\infty} \frac{1}{m(m+2)!} x^{2m} \right)$$

$$7.7.34 \text{ (p. 388)} \quad y_1 = x^2 \left( 1 - \frac{1}{2} x^2 \right); \quad y_2 = x^{-2} \left( 1 + \frac{9}{2} x^2 \right) - \frac{27}{2} \left( y_1 \ln x + \frac{7}{12} x^4 - x^2 \sum_{m=2}^{\infty} \frac{\left(\frac{3}{2}\right)^m}{m(m-1)(m+2)!} x^{2m} \right)$$

$$7.7.35 \text{ (p. 388)} \quad y_1 = \sum_{m=0}^{\infty} (-1)^m (m+1) x^{2m}; \quad y_2 = x^{-4}$$

$$7.7.36 \text{ (p. 388)} \quad y_1 = x^{5/2} \sum_{m=0}^{\infty} \frac{(-1)^m}{(m+1)(m+2)(m+3)} x^{2m}; \quad y_2 = x^{-7/2} (1+x^2)^2$$

$$7.7.37 \text{ (p. 388)} \quad y_1 = \frac{x^7}{5} \sum_{m=0}^{\infty} (-1)^m (m+5) x^{2m}; \quad y_2 = x^{-1} (1-2x^2+3x^4-4x^6)$$

$$7.7.38 \text{ (p. 389)} \quad y_1 = x^3 \sum_{m=0}^{\infty} (-1)^m \frac{m+1}{2^m} \left( \prod_{j=1}^m \frac{2j+1}{j+5} \right) x^{2m}; \quad y_2 = x^{-7} \left( 1 + \frac{21}{8} x^2 + \frac{35}{16} x^4 + \frac{35}{64} x^6 \right)$$

$$7.7.39 \text{ (p. 389)} \quad y_1 = 2x^4 \sum_{m=0}^{\infty} (-1)^m \frac{\prod_{j=1}^m (4j+5)}{2^m (m+2)!} x^{2m}; \quad y_2 = 1 - \frac{1}{2} x^2$$

$$7.7.40 \text{ (p. 389)} \quad y_1 = x^{3/2} \sum_{m=0}^{\infty} \frac{(-1)^m \prod_{j=1}^m (2j-1)}{2^{m-1} (m+2)!} x^{2m}; \quad y_2 = x^{-5/2} \left( 1 + \frac{3}{2} x^2 \right)$$



$$7.7.42 \text{ (p. 389)} \quad y_1 = x^\nu \sum_{m=0}^{\infty} \frac{(-1)^m}{4^m m! \prod_{j=1}^m (j + \nu)} x^{2m};$$

$$y_2 = x^{-\nu} \sum_{m=0}^{\nu-1} \frac{(-1)^m}{4^m m! \prod_{j=1}^m (j - \nu)} x^{2m} - \frac{2}{4^\nu \nu! (\nu - 1)!} \left( y_1 \ln x - \frac{x^\nu}{2} \sum_{m=1}^{\infty} \frac{(-1)^m}{4^m m! \prod_{j=1}^m (j + \nu)} \left( \sum_{j=1}^m \frac{2j + \nu}{j(j + \nu)} \right) x^{2m} \right)$$

**Section 8.1 Answers, pp. 402–404**

- 8.1.1 (p. 402) (a)  $\frac{1}{s^2}$  (b)  $\frac{1}{(s+1)^2}$  (c)  $\frac{b}{s^2 - b^2}$  (d)  $\frac{-2s+5}{(s-1)(s-2)}$  (e)  $\frac{2}{s^3}$
- 8.1.2 (p. 402) (a)  $\frac{s^2+2}{[(s-1)^2+1][(s+1)^2+1]}$  (b)  $\frac{2}{s(s^2+4)}$  (c)  $\frac{s^2+8}{s(s^2+16)}$  (d)  $\frac{s^2-2}{s(s^2-4)}$   
 (e)  $\frac{4s}{(s^2-4)^2}$  (f)  $\frac{1}{s^2+4}$  (g)  $\frac{1}{\sqrt{2}} \frac{s+1}{s^2+1}$  (h)  $\frac{5s}{(s^2+4)(s^2+9)}$  (i)  $\frac{s^3+2s^2+4s+32}{(s^2+4)(s^2+16)}$
- 8.1.4 (p. 402) (a)  $f(3-) = -1, f(3) = f(3+) = 1$  (b)  $f(1-) = 3, f(1) = 4, f(1+) = 1$   
 (c)  $f\left(\frac{\pi}{2}-\right) = 1, f\left(\frac{\pi}{2}\right) = f\left(\frac{\pi}{2}+\right) = 2, f(\pi-) = 0, f(\pi) = f(\pi+) = -1$   
 (d)  $f(1-) = 1, f(1) = 2, f(1+) = 1, f(2-) = 0, f(2) = 3, f(2+) = 6$
- 8.1.5 (p. 402) (a)  $\frac{1 - e^{-(s+1)}}{s+1} + \frac{e^{-(s+2)}}{s+2}$  (b)  $\frac{1}{s} + e^{-4s} \left( \frac{1}{s^2} + \frac{3}{s} \right)$  (c)  $\frac{1 - e^{-s}}{s^2}$  (d)  $\frac{1 - e^{-(s-1)}}{(s-1)^2}$
- 8.1.7 (p. 402)  $\mathcal{L}(e^{\lambda t} \cos \omega t) = \frac{(s-\lambda)^2 - \omega^2}{((s-\lambda)^2 + \omega^2)^2}$   $\mathcal{L}(e^{\lambda t} \sin \omega t) = \frac{2\omega(s-\lambda)}{((s-\lambda)^2 + \omega^2)^2}$
- 8.1.15 (p. 403) (a)  $\tan^{-1} \frac{\omega}{s}, \quad s > 0$  (b)  $\frac{1}{2} \ln \frac{s^2}{s^2 + \omega^2}, \quad s > 0$  (c)  $\ln \frac{s-b}{s-a}, \quad s > \max(a, b)$   
 (d)  $\frac{1}{2} \ln \frac{s^2}{s^2 - 1}, \quad s > 1$  (e)  $\frac{1}{4} \ln \frac{s^2}{s^2 - 4}, \quad s > 2$
- 8.1.18 (p. 404) (a)  $\frac{1}{s^2} \tanh \frac{s}{2}$  (b)  $\frac{1}{s} \tanh \frac{s}{4}$  (c)  $\frac{1}{s^2+1} \coth \frac{\pi s}{2}$  (d)  $\frac{1}{(s^2+1)(1 - e^{-\pi s})}$

**Section 8.2 Answers, pp. 411–413**

- 8.2.1 (p. 411) (a)  $\frac{t^3 e^{7t}}{2}$  (b)  $2e^{2t} \cos 3t$  (c)  $\frac{e^{-2t}}{4} \sin 4t$  (d)  $\frac{2}{3} \sin 3t$  (e)  $t \cos t$   
 (f)  $\frac{e^{2t}}{2} \sinh 2t$  (g)  $\frac{2te^{2t}}{3} \sin 9t$  (h)  $\frac{2e^{3t}}{3} \sinh 3t$  (i)  $e^{2t} t \cos t$
- 8.2.2 (p. 411) (a)  $t^2 e^{7t} + \frac{17}{6} t^3 e^{7t}$  (b)  $e^{2t} \left( \frac{1}{6} t^3 + \frac{1}{6} t^4 + \frac{1}{40} t^5 \right)$  (c)  $e^{-3t} \left( \cos 3t + \frac{2}{3} \sin 3t \right)$   
 (d)  $2 \cos 3t + \frac{1}{3} \sin 3t$  (e)  $(1-t)e^{-t}$  (f)  $\cosh 3t + \frac{1}{3} \sinh 3t$  (g)  $\left( 1 - t - t^2 - \frac{1}{6} t^3 \right) e^{-t}$   
 (h)  $e^t \left( 2 \cos 2t + \frac{5}{2} \sin 2t \right)$  (i)  $1 - \cos t$  (j)  $3 \cosh t + 4 \sinh t$  (k)  $3e^t + 4 \cos 3t + \frac{1}{3} \sin 3t$   
 (l)  $3te^{-2t} - 2 \cos 2t - 3 \sin 2t$
- 8.2.3 (p. 412) (a)  $\frac{1}{4} e^{2t} - \frac{1}{4} e^{-2t} - e^{-t}$  (b)  $\frac{1}{5} e^{-4t} - \frac{41}{5} e^t + 5e^{3t}$  (c)  $-\frac{1}{2} e^{2t} - \frac{13}{10} e^{-2t} - \frac{1}{5} e^{3t}$   
 (d)  $-\frac{2}{5} e^{-4t} - \frac{3}{5} e^t$  (e)  $\frac{3}{20} e^{2t} - \frac{37}{12} e^{-2t} + \frac{1}{3} e^t + \frac{8}{5} e^{-3t}$  (f)  $\frac{39}{10} e^t + \frac{3}{14} e^{3t} + \frac{23}{105} e^{-4t} - \frac{7}{3} e^{2t}$
- 8.2.4 (p. 412) (a)  $\frac{4}{5} e^{-2t} - \frac{1}{2} e^{-t} - \frac{3}{10} \cos t + \frac{11}{10} \sin t$  (b)  $\frac{2}{5} \sin t + \frac{6}{5} \cos t + \frac{7}{5} e^{-t} \sin t - \frac{6}{5} e^{-t} \cos t$   
 (c)  $\frac{8}{13} e^{2t} - \frac{8}{13} e^{-t} \cos 2t + \frac{15}{26} e^{-t} \sin 2t$  (d)  $\frac{1}{2} t e^t + \frac{3}{8} e^t + e^{-2t} - \frac{11}{8} e^{-3t}$   
 (e)  $\frac{2}{3} t e^t + \frac{1}{9} e^t + t e^{-2t} - \frac{1}{9} e^{-2t}$  (f)  $-e^t + \frac{5}{2} t e^t + \cos t - \frac{3}{2} \sin t$
- 8.2.5 (p. 412) (a)  $\frac{3}{5} \cos 2t + \frac{1}{5} \sin 2t - \frac{3}{5} \cos 3t - \frac{2}{15} \sin 3t$  (b)  $-\frac{4}{15} \cos t + \frac{1}{15} \sin t + \frac{4}{15} \cos 4t - \frac{1}{60} \sin 4t$

- (c)  $\frac{5}{3} \cos t + \sin t - \frac{5}{3} \cos 2t - \frac{1}{2} \sin 2t$  (d)  $-\frac{1}{3} \cos \frac{t}{2} + \frac{2}{3} \sin \frac{t}{2} + \frac{1}{3} \cos t - \frac{1}{3} \sin t$   
 (e)  $\frac{1}{15} \cos \frac{t}{4} - \frac{8}{15} \sin \frac{t}{4} - \frac{1}{15} \cos 4t + \frac{1}{30} \sin 4t$  (f)  $\frac{2}{5} \cos \frac{t}{3} - \frac{3}{5} \sin \frac{t}{3} - \frac{2}{5} \cos \frac{t}{2} + \frac{2}{5} \sin \frac{t}{2}$
- 8.2.6 (p. 412)** (a)  $e^t(\cos 2t + \sin 2t) - e^{-t}(\cos 3t + \frac{4}{3} \sin 3t)$  (b)  $e^{3t}(-\cos 2t + \frac{3}{2} \sin 2t) + e^{-t}(\cos 2t + \frac{1}{2} \sin 2t)$   
 (c)  $e^{-2t}(\frac{1}{8} \cos t + \frac{1}{4} \sin t) - e^{2t}(\frac{1}{8} \cos 3t - \frac{1}{12} \sin 3t)$  (d)  $e^{2t}(\cos t + \frac{1}{2} \sin t) - e^{3t}(\cos 2t - \frac{1}{4} \sin 2t)$   
 (e)  $e^t(\frac{1}{5} \cos t + \frac{2}{5} \sin t) - e^{-t}(\frac{1}{5} \cos 2t + \frac{2}{5} \sin 2t)$  (f)  $e^{t/2}(-\cos t + \frac{9}{8} \sin t) + e^{-t/2}(\cos t - \frac{1}{8} \sin t)$
- 8.2.7 (p. 412)** (a)  $1 - \cos t$  (b)  $\frac{e^t}{16}(1 - \cos 4t)$  (c)  $\frac{4}{9}e^{2t} + \frac{5}{9}e^{-t} \sin 3t - \frac{4}{9}e^{-t} \cos 3t$  (d)  $3e^{t/2} - \frac{7}{2}e^t \sin 2t - 3e^t \cos 2t$   
 (e)  $\frac{1}{4}e^{3t} - \frac{1}{4}e^{-t} \cos 2t$  (f)  $\frac{1}{9}e^{2t} - \frac{1}{9}e^{-t} \cos 3t + \frac{5}{9}e^{-t} \sin 3t$
- 8.2.8 (p. 412)** (a)  $-\frac{3}{10} \sin t + \frac{2}{5} \cos t - \frac{3}{4}e^t + \frac{7}{20}e^{3t}$  (b)  $-\frac{3}{5}e^{-t} \sin t + \frac{1}{5}e^{-t} \cos t - \frac{1}{2}e^{-t} + \frac{3}{10}e^t$   
 (c)  $-\frac{1}{10}e^t \sin t - \frac{7}{10}e^t \cos t + \frac{1}{5}e^{-t} + \frac{1}{2}e^{2t}$  (d)  $-\frac{1}{2}e^t + \frac{7}{10}e^{-t} - \frac{1}{5} \cos 2t + \frac{3}{5} \sin 2t$   
 (e)  $\frac{3}{10} + \frac{1}{10}e^{2t} + \frac{1}{10}e^t \sin 2t - \frac{2}{5}e^t \cos 2t$  (f)  $-\frac{4}{9}e^{2t} \cos 3t + \frac{1}{3}e^{2t} \sin 3t - \frac{5}{9}e^{2t} + e^t$
- 8.2.9 (p. 413)**  $\frac{1}{a}e^{\frac{b}{a}t} f\left(\frac{t}{a}\right)$

**Section 8.3 Answers, pp. 418–419**

- 8.3.1 (p. 418)**  $y = \frac{1}{6}e^t - \frac{9}{2}e^{-t} + \frac{16}{3}e^{-2t}$  **8.3.2 (p. 418)**  $y = -\frac{1}{3} + \frac{8}{15}e^{3t} + \frac{4}{5}e^{-2t}$   
**8.3.3 (p. 418)**  $y = -\frac{23}{15}e^{-2t} + \frac{1}{3}e^t + \frac{1}{5}e^{3t}$  **8.3.4 (p. 418)**  $y = -\frac{1}{4}e^{2t} + \frac{17}{20}e^{-2t} + \frac{2}{5}e^{3t}$   
**8.3.5 (p. 418)**  $y = \frac{11}{15}e^{-2t} + \frac{1}{6}e^t + \frac{1}{10}e^{3t}$  **8.3.6 (p. 418)**  $y = e^t + 2e^{-2t} - 2e^{-t}$   
**8.3.7 (p. 418)**  $y = \frac{5}{3} \sin t - \frac{1}{3} \sin 2t$  **8.3.8 (p. 418)**  $y = 4e^t - 4e^{2t} + e^{3t}$   
**8.3.9 (p. 418)**  $y = -\frac{7}{2}e^{2t} + \frac{13}{3}e^t + \frac{1}{6}e^{4t}$  **8.3.10 (p. 418)**  $y = \frac{5}{2}e^t - 4e^{2t} + \frac{1}{2}e^{3t}$   
**8.3.11 (p. 418)**  $y = \frac{1}{3}e^t - 2e^{-t} + \frac{5}{3}e^{-2t}$  **8.3.12 (p. 418)**  $y = 2 - e^{-2t} + e^t$   
**8.3.13 (p. 418)**  $y = 1 - \cos 2t + \frac{1}{2} \sin 2t$  **8.3.14 (p. 418)**  $y = -\frac{1}{3} + \frac{8}{15}e^{3t} + \frac{4}{5}e^{-2t}$   
**8.3.15 (p. 418)**  $y = \frac{1}{6}e^t - \frac{2}{3}e^{-2t} + \frac{1}{2}e^{-t}$  **8.3.16 (p. 418)**  $y = -1 + e^t + e^{-t}$   
**8.3.17 (p. 418)**  $y = \cos 2t - \sin 2t + \sin t$  **8.3.18 (p. 418)**  $y = \frac{7}{3} - \frac{7}{2}e^{-t} + \frac{1}{6}e^{3t}$   
**8.3.19 (p. 418)**  $y = 1 + \cos t$  **8.3.20 (p. 418)**  $y = t + \sin t$  **8.3.21 (p. 418)**  $y = t - 6 \sin t + \cos t + \sin 2t$   
**8.3.22 (p. 418)**  $y = e^{-t} + 4e^{-2t} - 4e^{-3t}$  **8.3.23 (p. 418)**  $y = -3 \cos t - 2 \sin t + e^{-t}(2 + 5t)$   
**8.3.24 (p. 419)**  $y = -\sin t - 2 \cos t + 3e^{3t} + e^{-t}$  **8.3.25 (p. 419)**  $y = (3t + 4) \sin t - (2t + 6) \cos t$   
**8.3.26 (p. 419)**  $y = -(2t + 2) \cos 2t + \sin 2t + 3 \cos t$  **8.3.27 (p. 419)**  $y = e^t(\cos t - 3 \sin t) + e^{3t}$   
**8.3.28 (p. 419)**  $y = -1 + t + e^{-t}(3 \cos t - 5 \sin t)$  **8.3.29 (p. 419)**  $y = 4 \cos t - 3 \sin t - e^t(3 \cos t - 8 \sin t)$   
**8.3.30 (p. 419)**  $y = e^{-t} - 2e^t + e^{-2t}(\cos 3t - 11/3 \sin 3t)$   
**8.3.31 (p. 419)**  $y = e^{-t}(\sin t - \cos t) + e^{-2t}(\cos t + 4 \sin t)$   
**8.3.32 (p. 419)**  $y = \frac{1}{5}e^{2t} - \frac{4}{3}e^t + \frac{32}{15}e^{-t/2}$  **8.3.33 (p. 419)**  $y = \frac{1}{7}e^{2t} - \frac{2}{5}e^{t/2} + \frac{9}{35}e^{-t/3}$   
**8.3.34 (p. 419)**  $y = e^{-t/2}(5 \cos(t/2) - \sin(t/2)) + 2t - 4$   
**8.3.35 (p. 419)**  $y = \frac{1}{17}(12 \cos t + 20 \sin t - 3e^{t/2}(4 \cos t + \sin t)).$

$$8.3.36 \text{ (p. 419)} \quad y = \frac{e^{-t/2}}{10}(5t + 26) - \frac{1}{5}(3 \cos t + \sin t) \quad 8.3.37 \text{ (p. 419)} \quad y = \frac{1}{100}(3e^{3t} - e^{t/3}(3 + 310t))$$

**Section 8.4 Answers, pp. 427–430**

$$8.4.1 \text{ (p. 427)} \quad 1 + u(t-4)(t-1); \frac{1}{s} + e^{-4s} \left( \frac{1}{s^2} + \frac{3}{s} \right) \quad 8.4.2 \text{ (p. 427)} \quad t + u(t-1)(1-t); \frac{1-e^{-s}}{s^2}$$

$$8.4.3 \text{ (p. 427)} \quad 2t - 1 - u(t-2)(t-1); \left( \frac{2}{s^2} - \frac{1}{s} \right) - e^{-2s} \left( \frac{1}{s^2} + \frac{1}{s} \right)$$

$$8.4.4 \text{ (p. 427)} \quad 1 + u(t-1)(t+1); \frac{1}{s} + e^{-s} \left( \frac{1}{s^2} + \frac{2}{s} \right)$$

$$8.4.5 \text{ (p. 427)} \quad t - 1 + u(t-2)(5-t); \frac{1}{s^2} - \frac{1}{s} - e^{-2s} \left( \frac{1}{s^2} - \frac{3}{s} \right)$$

$$8.4.6 \text{ (p. 427)} \quad t^2(1-u(t-1)); \frac{2}{s^3} - e^{-s} \left( \frac{2}{s^3} + \frac{2}{s^2} + \frac{1}{s} \right)$$

$$8.4.7 \text{ (p. 428)} \quad u(t-2)(t^2+3t); e^{-2s} \left( \frac{2}{s^3} + \frac{7}{s^2} + \frac{10}{s} \right)$$

$$8.4.8 \text{ (p. 428)} \quad t^2 + 2 + u(t-1)(t-t^2-2); \frac{2}{s^3} + \frac{2}{s} - e^{-s} \left( \frac{2}{s^3} + \frac{1}{s^2} + \frac{2}{s} \right)$$

$$8.4.9 \text{ (p. 428)} \quad te^t + u(t-1)(e^t - te^t); \frac{1 - e^{-(s-1)}}{(s-1)^2}$$

$$8.4.10 \text{ (p. 428)} \quad e^{-t} + u(t-1)(e^{-2t} - e^{-t}); \frac{1 - e^{-(s+1)}}{s+1} + \frac{e^{-(s+2)}}{s+2}$$

$$8.4.11 \text{ (p. 428)} \quad -t + 2u(t-2)(t-2) - u(t-3)(t-5); -\frac{1}{s^2} + \frac{2e^{-2s}}{s^2} + e^{-3s} \left( \frac{2}{s} - \frac{1}{s^2} \right)$$

$$8.4.12 \text{ (p. 428)} \quad [u(t-1) - u(t-2)]t; e^{-s} \left( \frac{1}{s^2} + \frac{1}{s} \right) - e^{-2s} \left( \frac{1}{s^2} + \frac{2}{s} \right)$$

$$8.4.13 \text{ (p. 428)} \quad t + u(t-1)(t^2-t) - u(t-2)t^2; \frac{1}{s^2} + e^{-s} \left( \frac{2}{s^3} + \frac{1}{s^2} \right) - e^{-2s} \left( \frac{2}{s^3} + \frac{4}{s^2} + \frac{4}{s} \right)$$

$$8.4.14 \text{ (p. 428)} \quad t + u(t-1)(2-2t) + u(t-2)(4+t); \frac{1}{s^2} - 2\frac{e^{-s}}{s^2} + e^{-2s} \left( \frac{1}{s^2} + \frac{6}{s} \right)$$

$$8.4.15 \text{ (p. 428)} \quad \sin t + u(t-\pi/2)\sin t + u(t-\pi)(\cos t - 2\sin t); \frac{1 + e^{-\frac{\pi}{2}s} - e^{-\pi s}}{s^2 + 1}$$

$$8.4.16 \text{ (p. 428)} \quad 2 - 2u(t-1)t + u(t-3)(5t-2); \frac{2}{s} - e^{-s} \left( \frac{2}{s^2} + \frac{2}{s} \right) + e^{-3s} \left( \frac{5}{s^2} + \frac{13}{s} \right)$$

$$8.4.17 \text{ (p. 428)} \quad 3 + u(t-2)(3t-1) + u(t-4)(t-2); \frac{3}{s} + e^{-2s} \left( \frac{3}{s^2} + \frac{5}{s} \right) + e^{-4s} \left( \frac{1}{s^2} + \frac{2}{s} \right)$$

$$8.4.18 \text{ (p. 428)} \quad (t+1)^2 + u(t-1)(2t+3); \frac{2}{s^3} + \frac{2}{s^2} + \frac{1}{s} + e^{-s} \left( \frac{2}{s^2} + \frac{5}{s} \right)$$

$$8.4.19 \text{ (p. 428)} \quad u(t-2)e^{2(t-2)} = \begin{cases} 0, & 0 \leq t < 2, \\ e^{2(t-2)}, & t \geq 2. \end{cases}$$

$$8.4.20 \text{ (p. 428)} \quad u(t-1)(1 - e^{-(t-1)}) = \begin{cases} 0, & 0 \leq t < 1, \\ 1 - e^{-(t-1)}, & t \geq 1. \end{cases}$$

$$8.4.21 \text{ (p. 428)} \quad u(t-1)\frac{(t-1)^2}{2} + u(t-2)(t-2) = \begin{cases} 0, & 0 \leq t < 1, \\ \frac{(t-1)^2}{2}, & 1 \leq t < 2, \\ \frac{t^2-3}{2}, & t \geq 2. \end{cases}$$

$$8.4.22 \text{ (p. 428)} \quad 2 + t + u(t-1)(4-t) + u(t-3)(t-2) = \begin{cases} 2+t, & 0 \leq t < 1, \\ 6, & 1 \leq t < 3, \\ t+4, & t \geq 3. \end{cases}$$

$$8.4.23 \text{ (p. 429)} \quad 5 - t + u(t-3)(7t-15) + \frac{3}{2}u(t-6)(t-6)^2 = \begin{cases} 5-t, & 0 \leq t < 3, \\ 6t-10, & 3 \leq t < 6, \\ 44-12t+\frac{3}{2}t^2, & t \geq 6. \end{cases}$$

$$8.4.24 \text{ (p. 429)} \quad u(t-\pi)e^{-2(t-\pi)}(2\cos t - 5\sin t) = \begin{cases} 0, & 0 \leq t < \pi, \\ e^{-2(t-\pi)}(2\cos t - 5\sin t), & t \geq \pi. \end{cases}$$

$$8.4.25 \text{ (p. 429)} \quad 1 - \cos t + u(t-\pi/2)(3\sin t + \cos t) = \begin{cases} 1 - \cos t, & 0 \leq t < \frac{\pi}{2}, \\ 1 + 3\sin t, & t \geq \frac{\pi}{2}. \end{cases}$$

$$8.4.26 \text{ (p. 429)} \quad u(t-2)(4e^{-(t-2)} - 4e^{2(t-2)} + 2e^{(t-2)}) = \begin{cases} 0, & 0 \leq t < 2, \\ 4e^{-(t-2)} - 4e^{2(t-2)} + 2e^{(t-2)}, & t \geq 2. \end{cases}$$

$$8.4.27 \text{ (p. 429)} \quad 1 + t + u(t-1)(2t+1) + u(t-3)(3t-5) = \begin{cases} t+1, & 0 \leq t < 1, \\ 3t+2, & 1 \leq t < 3, \\ 6t-3, & t \geq 3. \end{cases}$$

$$8.4.28 \text{ (p. 429)} \quad 1 - t^2 + u(t-2)\left(-\frac{t^2}{2} + 2t + 1\right) + u(t-4)(t-4) = \begin{cases} 1 - t^2, & 0 \leq t < 2, \\ -\frac{3t^2}{2} + 2t + 2, & 2 \leq t < 4, \\ -\frac{3t^2}{2} + 3t - 2, & t \geq 4. \end{cases}$$

$$8.4.29 \text{ (p. 429)} \quad \frac{e^{-\tau s}}{s} \quad 8.4.30 \text{ (p. 429)} \quad \text{For each } t \text{ only finitely many terms are nonzero.}$$

$$8.4.33 \text{ (p. 430)} \quad 1 + \sum_{m=1}^{\infty} u(t-m); \frac{1}{s(1-e^{-s})} \quad 8.4.34 \text{ (p. 430)} \quad 1 + 2 \sum_{m=1}^{\infty} (-1)^m u(t-m); \frac{1}{s}; \frac{1-e^{-s}}{1+e^{-s}}$$

$$8.4.35 \text{ (p. 430)} \quad 1 + \sum_{m=1}^{\infty} (2m+1)u(t-m); \frac{e^{-s}(1+e^{-s})}{s(1-e^{-s})^2} \quad 8.4.36 \text{ (p. 430)} \quad \sum_{m=1}^{\infty} (-1)^m (2m-1)u(t-m); \frac{1}{s} \frac{(1-e^s)}{(1+e^s)^2}$$

### Section 8.5 Answers, pp. 437–439

$$8.5.1 \text{ (p. 437)} \quad y = 3(1 - \cos t) - 3u(t-\pi)(1 + \cos t)$$

$$8.5.2 \text{ (p. 437)} \quad y = 3 - 2\cos t + 2u(t-4)(t-4 - \sin(t-4)) \quad 8.5.3 \text{ (p. 437)} \quad y = -\frac{15}{2} + \frac{3}{2}e^{2t} - 2t + \frac{u(t-1)}{2}(e^{2(t-1)} - 2t + 1)$$

$$8.5.4 \text{ (p. 437)} \quad y = \frac{1}{2}e^t + \frac{13}{6}e^{-t} + \frac{1}{3}e^{2t} + u(t-2)\left(-1 + \frac{1}{2}e^{t-2} + \frac{1}{2}e^{-(t-2)} + \frac{1}{2}e^{t+2} - \frac{1}{6}e^{-(t-6)} - \frac{1}{3}e^{2t}\right)$$

$$8.5.5 \text{ (p. 437)} \quad y = -7e^t + 4e^{2t} + u(t-1)\left(\frac{1}{2} - e^{t-1} + \frac{1}{2}e^{2(t-1)}\right) - 2u(t-2)\left(\frac{1}{2} - e^{t-2} + \frac{1}{2}e^{2(t-2)}\right)$$

$$8.5.6 \text{ (p. 437)} \quad y = \frac{1}{3}\sin 2t - 3\cos 2t + \frac{1}{3}\sin t - 2u(t-\pi)\left(\frac{1}{3}\sin t + \frac{1}{6}\sin 2t\right) + u(t-2\pi)\left(\frac{1}{3}\sin t - \frac{1}{6}\sin 2t\right)$$

$$8.5.7 \text{ (p. 437)} \quad y = \frac{1}{4} - \frac{31}{12}e^{4t} + \frac{16}{3}e^t + u(t-1)\left(\frac{2}{3}e^{t-1} - \frac{1}{6}e^{4(t-1)} - \frac{1}{2}\right) + u(t-2)\left(\frac{1}{4} + \frac{1}{12}e^{4(t-2)} - \frac{1}{3}e^{t-2}\right)$$

$$8.5.8 \text{ (p. 437)} \quad y = \frac{1}{8}(\cos t - \cos 3t) - \frac{1}{8}u\left(t - \frac{3\pi}{2}\right)\left(\sin t - \cos t + \sin 3t - \frac{1}{3}\cos 3t\right)$$

$$8.5.9 \text{ (p. 437)} \quad y = \frac{t}{4} - \frac{1}{8}\sin 2t + \frac{1}{8}u\left(t - \frac{\pi}{2}\right)(\pi \cos 2t - \sin 2t + 2\pi - 2t)$$

- 8.5.10 (p. 437)  $y = t - \sin t - 2u(t - \pi)(t + \sin t + \pi \cos t)$
- 8.5.11 (p. 437)  $y = u(t - 2) \left( t - \frac{1}{2} + \frac{e^{2(t-2)}}{2} - 2e^{t-2} \right)$
- 8.5.12 (p. 437)  $y = t + \sin t + \cos t - u(t - 2\pi)(3t - 3 \sin t - 6\pi \cos t)$
- 8.5.13 (p. 437)  $y = \frac{1}{2} + \frac{1}{2}e^{-2t} - e^{-t} + u(t - 2) (2e^{-(t-2)} - e^{-2(t-2)} - 1)$
- 8.5.14 (p. 437)  $y = -\frac{1}{3} - \frac{1}{6}e^{3t} + \frac{1}{2}e^t + u(t - 1) \left( \frac{2}{3} + \frac{1}{3}e^{3(t-1)} - e^{t-1} \right)$
- 8.5.15 (p. 437)  $y = \frac{1}{4} (e^t + e^{-t}(11 + 6t)) + u(t - 1)(te^{-(t-1)} - 1)$
- 8.5.16 (p. 437)  $y = e^t - e^{-t} - 2te^{-t} - u(t - 1) (e^t - e^{-(t-2)} - 2(t - 1)e^{-(t-2)})$
- 8.5.17 (p. 437)  $y = te^{-t} + e^{-2t} + u(t - 1) (e^{-t}(2 - t) - e^{-(2t-1)})$
- 8.5.18 (p. 438)  $y = y = \frac{t^2 e^{2t}}{2} - te^{2t} - u(t - 2)(t - 2)^2 e^{2t}$
- 8.5.19 (p. 438)  $y = \frac{t^4}{12} + 1 - \frac{1}{12}u(t - 1)(t^4 + 2t^3 - 10t + 7) + \frac{1}{6}u(t - 2)(2t^3 + 3t^2 - 36t + 44)$
- 8.5.20 (p. 438)  $y = \frac{1}{2}e^{-t}(3 \cos t + \sin t) + \frac{1}{2} - u(t - 2\pi) \left( e^{-(t-2\pi)} \left( (\pi - 1) \cos t + \frac{2\pi - 1}{2} \sin t \right) + 1 - \frac{t}{2} \right) - \frac{1}{2}u(t - 3\pi) (e^{-(t-3\pi)}(3\pi \cos t + (3\pi + 1) \sin t) + t)$
- 8.5.21 (p. 438)  $y = \frac{t^2}{2} + \sum_{m=1}^{\infty} u(t - m) \frac{(t - m)^2}{2}$
- 8.5.22 (p. 438) (a)  $y = \begin{cases} 2m + 1 - \cos t, & 2m\pi \leq t < (2m + 1)\pi \quad (m = 0, 1, \dots) \\ 2m, & (2m - 1)\pi \leq t < 2m\pi \quad (m = 1, 2, \dots) \end{cases}$
- (b)  $y = (m + 1)(t - \sin t - m\pi \cos t)$ ,  $2m\pi \leq t < (2m + 2)\pi$  ( $m = 0, 1, \dots$ )
- (c)  $y = (-1)^m - (2m + 1) \cos t$ ,  $m\pi \leq t < (m + 1)\pi$  ( $m = 0, 1, \dots$ )
- (d)  $y = \frac{e^{m+1} - 1}{2(e - 1)} (e^{t-m} + e^{-t}) - m - 1$ ,  $m \leq t < m + 1$  ( $m = 0, 1, \dots$ )
- (e)  $y = \left( m + 1 - \left( \frac{e^{2(m+1)\pi} - 1}{e^{2\pi} - 1} \right) e^{-t} \right) \sin t$ ,  $2m\pi \leq t < 2(m + 1)\pi$  ( $m = 0, 1, \dots$ )
- (f)  $y = \frac{m + 1}{2} - e^{t-m} \frac{e^{m+1} - 1}{e - 1} + \frac{1}{2} e^{2(t-m)} \frac{e^{2m+2} - 1}{e^2 - 1}$ ,  $m \leq t < m + 1$  ( $m = 0, 1, \dots$ )

## Section 8.6 Answers, pp. 448–452

- 8.6.1 (p. 448) (a)  $\frac{1}{2} \int_0^t \tau \sin 2(t-\tau) d\tau$  (b)  $\int_0^t e^{-2\tau} \cos 3(t-\tau) d\tau$   
 (c)  $\frac{1}{2} \int_0^t \sin 2\tau \cos 3(t-\tau) d\tau$  or  $\frac{1}{3} \int_0^t \sin 3\tau \cos 2(t-\tau) d\tau$  (d)  $\int_0^t \cos \tau \sin(t-\tau) d\tau$   
 (e)  $\int_0^t e^{a\tau} d\tau$  (f)  $e^{-t} \int_0^t \sin(t-\tau) d\tau$  (g)  $e^{-2t} \int_0^t \tau e^\tau \sin(t-\tau) d\tau$   
 (h)  $\frac{e^{-2t}}{2} \int_0^t \tau^2(t-\tau)e^{3\tau} d\tau$  (i)  $\int_0^t (t-\tau)e^\tau \cos \tau d\tau$  (j)  $\int_0^t e^{-3\tau} \cos \tau \cos 2(t-\tau) d\tau$   
 (k)  $\frac{1}{4!5!} \int_0^t \tau^4(t-\tau)^5 e^{3\tau} d\tau$  (l)  $\frac{1}{4} \int_0^t \tau^2 e^\tau \sin 2(t-\tau) d\tau$   
 (m)  $\frac{1}{2} \int_0^t \tau(t-\tau)^2 e^{2(t-\tau)} d\tau$  (n)  $\frac{1}{5!6!} \int_0^t (t-\tau)^5 e^{2(t-\tau)} \tau^6 d\tau$
- 8.6.2 (p. 449) (a)  $\frac{as}{(s^2+a^2)(s^2+b^2)}$  (b)  $\frac{a}{(s-1)(s^2+a^2)}$  (c)  $\frac{as}{(s^2-a^2)^2}$  (d)  $\frac{2\omega s(s^2-\omega^2)}{(s^2+\omega^2)^4}$   
 (e)  $\frac{(s-1)\omega}{((s-1)^2+\omega^2)^2}$  (f)  $\frac{2}{(s-2)^3(s-1)^2}$  (g)  $\frac{s+1}{(s+2)^2[(s+1)^2+\omega^2]}$   
 (h)  $\frac{1}{(s-3)((s-1)^2-1)}$  (i)  $\frac{2}{(s-2)^2(s^2+4)}$  (j)  $\frac{6}{s^4(s-1)}$  (k)  $\frac{3 \cdot 6!}{s^7[(s+1)^2+9]}$   
 (l)  $\frac{12}{s^7}$  (m)  $\frac{2 \cdot 7!}{s^8[(s+1)^2+4]}$  (n)  $\frac{48}{s^5(s^2+4)}$
- 8.6.3 (p. 449) (a)  $y = \frac{2}{\sqrt{5}} \int_0^t f(t-\tau)e^{-3\tau/2} \sinh \frac{\sqrt{5}\tau}{2} d\tau$  (b)  $y = \frac{1}{2} \int_0^t f(t-\tau) \sin 2\tau d\tau$   
 (c)  $y = \int_0^t \tau e^{-\tau} f(t-\tau) d\tau$  (d)  $y(t) = -\frac{1}{k} \sin kt + \cos kt + \frac{1}{k} \int_0^t f(t-\tau) \sin k\tau d\tau$   
 (e)  $y = -2te^{-3t} + \int_0^t \tau e^{-3\tau} f(t-\tau) d\tau$  (f)  $y = \frac{3}{2} \sinh 2t + \frac{1}{2} \int_0^t f(t-\tau) \sinh 2\tau d\tau$   
 (g)  $y = e^{3t} + \int_0^t (e^{3\tau} - e^{2\tau})f(t-\tau) d\tau$  (h)  $y = \frac{k_1}{\omega} \sin \omega t + k_0 \cos \omega t + \frac{1}{\omega} \int_0^t f(t-\tau) \sin \omega\tau d\tau$
- 8.6.4 (p. 449) (a)  $y = \sin t$  (b)  $y = te^{-t}$  (c)  $y = 1 + 2te^t$  (d)  $y = t + \frac{t^2}{2}$   
 (e)  $y = 4 + \frac{5}{2}t^2 + \frac{1}{24}t^4$  (f)  $y = 1 - t$
- 8.6.5 (p. 450) (a)  $\frac{7!8!}{16!}t^{16}$  (b)  $\frac{13!7!}{21!}t^{21}$  (c)  $\frac{6!7!}{14!}t^{14}$  (d)  $\frac{1}{2}(e^{-t} + \sin t - \cos t)$  (e)  $\frac{1}{3}(\cos t - \cos 2t)$

## Section 8.7 Answers, pp. 460–461

- 8.7.1 (p. 460)  $y = \frac{1}{2}e^{2t} - 4e^{-t} + \frac{11}{2}e^{-2t} + 2u(t-1)(e^{-(t-1)} - e^{-2(t-1)})$
- 8.7.2 (p. 460)  $y = 2e^{-2t} + 5e^{-t} + \frac{5}{3}u(t-1)(e^{(t-1)} - e^{-2(t-1)})$
- 8.7.3 (p. 460)  $y = \frac{1}{6}e^{2t} - \frac{2}{3}e^{-t} - \frac{1}{2}e^{-2t} + \frac{5}{2}u(t-1) \sinh 2(t-1)$
- 8.7.4 (p. 460)  $y = \frac{1}{8}(8 \cos t - 5 \sin t - \sin 3t) - 2u(t-\pi/2) \cos t$
- 8.7.5 (p. 460)  $y = 1 - \cos 2t + \frac{1}{2} \sin 2t + \frac{1}{2}u(t-3\pi) \sin 2t$
- 8.7.6 (p. 460)  $y = 4e^t + 3e^{-t} - 8 + 2u(t-2) \sinh(t-2)$
- 8.7.7 (p. 460)  $y = \frac{1}{2}e^t - \frac{7}{2}e^{-t} + 2 + 3u(t-6)(1 - e^{-(t-6)})$

- 8.7.8 (p. 460)  $y = e^{2t} + 7 \cos 2t - \sin 2t - \frac{1}{2}u(t - \pi/2) \sin 2t$
- 8.7.9 (p. 460)  $y = \frac{1}{2}(1 + e^{-2t}) + u(t - 1)(e^{-(t-1)} - e^{-2(t-1)})$
- 8.7.10 (p. 460)  $y = \frac{1}{4}e^t + \frac{1}{4}e^{-t}(2t - 5) + 2u(t - 2)(t - 2)e^{-(t-2)}$
- 8.7.11 (p. 460)  $y = \frac{1}{6}(2 \sin t + 5 \sin 2t) - \frac{1}{2}u(t - \pi/2) \sin 2t$
- 8.7.12 (p. 460)  $y = e^{-t}(\sin t - \cos t) - e^{-(t-\pi)} \sin t - 3u(t - 2\pi)e^{-(t-2\pi)} \sin t$
- 8.7.13 (p. 460)  $y = e^{-2t} \left( \cos 3t + \frac{4}{3} \sin 3t \right) - \frac{1}{3}u(t - \pi/6)e^{-2(t-\pi/6)} \cos 3t - \frac{2}{3}u(t - \pi/3)e^{-2(t-\pi/3)} \sin 3t$
- 8.7.14 (p. 460)  $y = \frac{7}{10}e^{2t} - \frac{6}{5}e^{-t/2} - \frac{1}{2} + \frac{1}{5}u(t - 2)(e^{2(t-2)} - e^{-(t-2)/2})$
- 8.7.15 (p. 460)  $y = \frac{1}{17}(12 \cos t + 20 \sin t) + \frac{1}{34}e^{t/2}(10 \cos t - 11 \sin t) - u(t - \pi/2)e^{(2t-\pi)/4} \cos t + u(t - \pi)e^{(t-\pi)/2} \sin t$
- 8.7.16 (p. 460)  $y = \frac{1}{3}(\cos t - \cos 2t - 3 \sin t) - 2u(t - \pi/2) \cos t + 3u(t - \pi) \sin t$
- 8.7.17 (p. 460)  $y = e^t - e^{-t}(1 + 2t) - 5u(t - 1) \sinh(t - 1) + 3u(t - 2) \sinh(t - 2)$
- 8.7.18 (p. 460)  $y = \frac{1}{4}(e^t - e^{-t}(1 + 6t)) - u(t - 1)e^{-(t-1)} + 2u(t - 2)e^{-(t-2)}$
- 8.7.19 (p. 460)  $y = \frac{5}{3} \sin t - \frac{1}{3} \sin 2t + \frac{1}{3}u(t - \pi)(\sin 2t + 2 \sin t) + u(t - 2\pi) \sin t$
- 8.7.20 (p. 460)  $y = \frac{3}{4} \cos 2t - \frac{1}{2} \sin 2t + \frac{1}{4} + \frac{1}{4}u(t - \pi/2)(1 + \cos 2t) + \frac{1}{2}u(t - \pi) \sin 2t + \frac{3}{2}u(t - 3\pi/2) \sin 2t$
- 8.7.21 (p. 460)  $y = \cos t - \sin t$     8.7.22 (p. 460)  $y = \frac{1}{4}(8e^{3t} - 12e^{-2t})$
- 8.7.23 (p. 460)  $y = 5(e^{-2t} - e^{-t})$     8.7.24 (p. 460)  $y = e^{-2t}(1 + 6t)$
- 8.7.25 (p. 460)  $y = \frac{1}{4}e^{-t/2}(4 - 19t)$
- 8.7.29 (p. 461)  $y = (-1)^k m \omega_1 R e^{-c\tau/2m} \delta(t - \tau)$  if  $\omega_1 \tau - \phi = (2k + 1)\pi/2$  ( $k = \text{integer}$ )
- 8.7.30 (p. 461) (a)  $y = \frac{(e^{m+1} - 1)(e^{t-m} - e^{-t})}{2(e - 1)}$ ,  $m \leq t < m + 1$ , ( $m = 0, 1, \dots$ )
- (b)  $y = (m + 1) \sin t$ ,  $2m\pi \leq t < 2(m + 1)\pi$ , ( $m = 0, 1, \dots$ )
- (c)  $y = e^{2(t-m)} \frac{e^{2m+2} - 1}{e^2 - 1} - e^{(t-m)} \frac{e^{m+1} - 1}{e - 1}$ ,  $m \leq t < m + 1$  ( $m = 0, 1, \dots$ )
- (d)  $y = \begin{cases} 0, & 2m\pi \leq t < (2m + 1)\pi, \\ -\sin t, & (2m + 1)\pi \leq t < (2m + 2)\pi, \end{cases}$  ( $m = 0, 1, \dots$ )

Section 9.1 Answers, pp. 470–474

- 9.1.2 (p. 471)  $y = 2x^2 - 3x^3 + \frac{1}{x}$     9.1.3 (p. 471)  $y = 2e^x + 3e^{-x} - e^{2x} + e^{-3x}$     9.1.4 (p. 471)  $y_i = \frac{(x - x_0)^{i-1}}{(i - 1)!}$ ,  $1 \leq i \leq n$
- 9.1.5 (p. 471) (b)  $y_1 = -\frac{1}{2}x^3 + x^2 + \frac{1}{2x}$ ,  $y_2 = \frac{1}{3}x^2 - \frac{1}{3x}$ ,  $y_3 = \frac{1}{4}x^3 - \frac{1}{3}x^2 + \frac{1}{12x}$
- (c)  $y = k_0 y_1 + k_1 y_2 + k_2 y_3$
- 9.1.7 (p. 471)  $2e^{-x^2}$     9.1.8 (p. 472)  $\sqrt{2}K \cos x$     9.1.9 (p. 472) (a)  $W(x) = 2e^{3x}$     (d)  $y = e^x(c_1 + c_2 x + c_3 x^2)$
- 9.1.10 (p. 472) (a) 2 (b)  $-e^{3x}$  (c) 4 (d)  $4/x^2$  (e) 1 (f)  $2x$  (g)  $2/x^2$  (h)  $e^x(x^2 - 2x + 2)$
- (i)  $-240/x^5$  (j)  $6e^{2x}(2x - 1)$  (l)  $-128x$
- 9.1.24 (p. 474) (a)  $y''' = 0$  (b)  $xy''' - y'' - xy' + y = 0$  (c)  $(2x - 3)y''' - 2y'' - (2x - 5)y' = 0$
- (d)  $(x^2 - 2x + 2)y''' - x^2 y'' + 2xy' - 2y = 0$  (e)  $x^3 y''' + x^2 y'' - 2xy' + 2y = 0$
- (f)  $(3x - 1)y''' - (12x - 1)y'' + 9(x + 1)y' - 9y = 0$
- (g)  $x^4 y^{(4)} + 5x^3 y''' - 3x^2 y'' - 6xy' + 6y = 0$

- (h)  $x^4 y^{(4)} + 3x^2 y''' - x^2 y'' + 2xy' - 2y = 0$   
 (i)  $(2x - 1)y^{(4)} - 4xy''' + (5 - 2x)y'' + 4xy' - 4y = 0$   
 (j)  $xy^{(4)} - y''' - 4xy'' + 4y' = 0$

## Section 9.2 Answers, pp. 482–487

- 9.2.1 (p. 482)  $y = e^x(c_1 + c_2x + c_3x^2)$  9.2.2 (p. 482)  $y = c_1e^x + c_2e^{-x} + c_3 \cos 3x + c_4 \sin 3x$   
 9.2.3 (p. 482)  $y = c_1e^x + c_2 \cos 4x + c_3 \sin 4x$  9.2.4 (p. 482)  $y = c_1e^x + c_2e^{-x} + c_3e^{-3x/2}$   
 9.2.5 (p. 482)  $y = c_1e^{-x} + e^{-2x}(c_1 \cos x + c_2 \sin x)$  9.2.6 (p. 482)  $y = c_1e^x + e^{x/2}(c_2 + c_3x)$   
 9.2.7 (p. 482)  $y = e^{-x/3}(c_1 + c_2x + c_3x^2)$  9.2.8 (p. 482)  $y = c_1 + c_2x + c_3 \cos x + c_4 \sin x$   
 9.2.9 (p. 482)  $y = c_1e^{2x} + c_2e^{-2x} + c_3 \cos 2x + c_4 \sin 2x$   
 9.2.10 (p. 482)  $y = (c_1 + c_2x) \cos \sqrt{6}x + (c_3 + c_4x) \sin \sqrt{6}x$   
 9.2.11 (p. 482)  $y = e^{3x/2}(c_1 + c_2x) + e^{-3x/2}(c_3 + c_4x)$   
 9.2.12 (p. 482)  $y = c_1e^{-x/2} + c_2e^{-x/3} + c_3 \cos x + c_4 \sin x$   
 9.2.13 (p. 482)  $y = c_1e^x + c_2e^{-2x} + c_3e^{-x/2} + c_4e^{-3x/2}$  9.2.14 (p. 482)  $y = e^x(c_1 + c_2x + c_3 \cos x + c_4 \sin x)$   
 9.2.15 (p. 483)  $y = \cos 2x - 2 \sin 2x + e^{2x}$  9.2.16 (p. 483)  $y = 2e^x + 3e^{-x} - 5e^{-3x}$   
 9.2.17 (p. 483)  $y = 2e^x + 3xe^x - 4e^{-x}$   
 9.2.18 (p. 483)  $y = 2e^{-x} \cos x - 3e^{-x} \sin x + 4e^{2x}$  9.2.19 (p. 483)  $y = \frac{9}{5}e^{-5x/3} + e^x(1 + 2x)$   
 9.2.20 (p. 483)  $y = e^{2x}(1 - 3x + 2x^2)$  9.2.21 (p. 483)  $y = e^{3x}(2 - x) + 4e^{-x/2}$   
 9.2.22 (p. 483)  $y = e^{x/2}(1 - 2x) + 3e^{-x/2}$  9.2.23 (p. 483)  $y = \frac{1}{8}(5e^{2x} + e^{-2x} + 10 \cos 2x + 4 \sin 2x)$   
 9.2.24 (p. 483)  $y = -4e^x + e^{2x} - e^{4x} + 2e^{-x}$  9.2.25 (p. 483)  $y = 2e^x - e^{-x}$   
 9.2.26 (p. 483)  $y = e^{2x} + e^{-2x} + e^{-x}(3 \cos x + \sin x)$  9.2.27 (p. 483)  $y = 2e^{-x/2} + \cos 2x - \sin 2x$   
 9.2.28 (p. 483) (a)  $\{e^x, xe^x, e^{2x}\}$ : 1 (b)  $\{\cos 2x, \sin 2x, e^{3x}\}$ : 26  
 (c)  $\{e^{-x} \cos x, e^{-x} \sin x, e^x\}$ : 5 (d)  $\{1, x, x^2, e^x\}$ :  $2e^x$   
 (e)  $\{e^x, e^{-x}, \cos x, \sin x\}$ : 8 (f)  $\{\cos x, \sin x, e^x \cos x, e^x \sin x\}$ : 5  
 9.2.29 (p. 483)  $\{e^{-3x} \cos 2x, e^{-3x} \sin 2x, e^{2x}, xe^{2x}, 1, x, x^2\}$   
 9.2.30 (p. 483)  $\{e^x, xe^x, e^{x/2}, xe^{x/2}, x^2e^{x/2}, \cos x, \sin x\}$   
 9.2.31 (p. 483)  $\{\cos 3x, x \cos 3x, x^2 \cos 3x, \sin 3x, x \sin 3x, x^2 \sin 3x, 1, x\}$   
 9.2.32 (p. 483)  $\{e^{2x}, xe^{2x}, x^2e^{2x}, e^{-x}, xe^{-x}, 1\}$   
 9.2.33 (p. 483)  $\{\cos x, \sin x, \cos 3x, x \cos 3x, \sin 3x, x \sin 3x, e^{2x}\}$   
 9.2.34 (p. 483)  $\{e^{2x}, xe^{2x}, e^{-2x}, xe^{-2x}, \cos 2x, x \cos 2x, \sin 2x, x \sin 2x\}$   
 9.2.35 (p. 483)  $\{e^{-x/2} \cos 2x, xe^{-x/2} \cos 2x, x^2e^{-x/2} \cos 2x, e^{-x/2} \sin 2x, xe^{-x/2} \sin 2x, x^2e^{-x/2} \sin 2x\}$   
 9.2.36 (p. 483)  $\{1, x, x^2, e^{2x}, xe^{2x}, \cos 2x, x \cos 2x, \sin 2x, x \sin 2x\}$   
 9.2.37 (p. 483)  $\{\cos(x/2), x \cos(x/2), \sin(x/2), x \sin(x/2), \cos 2x/3, x \cos(2x/3), x^2 \cos(2x/3), \sin(2x/3), x \sin(2x/3), x^2 \sin(2x/3)\}$   
 9.2.38 (p. 483)  $\{e^{-x}, e^{3x}, e^x \cos 2x, e^x \sin 2x\}$  9.2.39 (p. 484) (b)  $e^{(a_1 + a_2 + \dots + a_n)x} \prod_{1 \leq i < j \leq n} (a_j - a_i)$   
 9.2.43 (p. 486) (a)  $\left\{e^x, e^{-x/2} \cos\left(\frac{\sqrt{3}}{2}x\right), e^{-x/2} \sin\left(\frac{\sqrt{3}}{2}x\right)\right\}$  (b)  $\left\{e^{-x}, e^{x/2} \cos\left(\frac{\sqrt{3}}{2}x\right), e^{x/2} \sin\left(\frac{\sqrt{3}}{2}x\right)\right\}$   
 (c)  $\{e^{2x} \cos 2x, e^{2x} \sin 2x, e^{-2x} \cos 2x, e^{-2x} \sin 2x\}$   
 (d)  $\left\{e^x, e^{-x}, e^{x/2} \cos\left(\frac{\sqrt{3}}{2}x\right), e^{x/2} \sin\left(\frac{\sqrt{3}}{2}x\right), e^{-x/2} \cos\left(\frac{\sqrt{3}}{2}x\right), e^{-x/2} \sin\left(\frac{\sqrt{3}}{2}x\right)\right\}$   
 (e)  $\{\cos 2x, \sin 2x, e^{-\sqrt{3}x} \cos x, e^{-\sqrt{3}x} \sin x, e^{\sqrt{3}x} \cos x, e^{\sqrt{3}x} \sin x\}$   
 (f)  $\left\{1, e^{2x}, e^{3x/2} \cos\left(\frac{\sqrt{3}}{2}x\right), e^{3x/2} \sin\left(\frac{\sqrt{3}}{2}x\right), e^{x/2} \cos\left(\frac{\sqrt{3}}{2}x\right), e^{x/2} \sin\left(\frac{\sqrt{3}}{2}x\right)\right\}$



$$(g) \left\{ e^{-x}, e^{x/2} \cos\left(\frac{\sqrt{3}}{2}x\right), e^{x/2} \sin\left(\frac{\sqrt{3}}{2}x\right), e^{-x/2} \cos\left(\frac{\sqrt{3}}{2}x\right), e^{-x/2} \sin\left(\frac{\sqrt{3}}{2}x\right) \right\}$$

**9.2.45 (p. 487)**  $y = c_1x^{r_1} + c_2x^{r_2} + c_3x^{r_3}$  ( $r_1, r_2, r_3$  **distinct**);  $y = c_1x^{r_1} + (c_2 + c_3 \ln x)x^{r_2}$  ( $r_1, r_2$  **distinct**);  $y = [c_1 + c_2 \ln x + c_3(\ln x)^2]x^{r_1}$ ;  $y = c_1x^{r_1} + x^\lambda[c_2 \cos(\omega \ln x) + c_3 \sin(\omega \ln x)]$

**Section 9.3 Answers, pp. 494–496**

**9.3.1 (p. 494)**  $y_p = e^{-x}(2+x-x^2)$  **9.3.2 (p. 494)**  $y_p = -\frac{e^{-3x}}{4}(3-x+x^2)$  **9.3.3 (p. 494)**  $y_p = e^x(1+x-x^2)$

**9.3.4 (p. 494)**  $y_p = e^{-2x}(1-5x+x^2)$ , **9.3.5 (p. 494)**  $y_p = -\frac{xe^x}{2}(1-x+x^2-x^3)$

**9.3.6 (p. 494)**  $y_p = x^2e^x(1+x)$  **9.3.7 (p. 494)**  $y_p = \frac{xe^{-2x}}{2}(2+x)$  **9.3.8 (p. 494)**  $y_p = \frac{x^2e^x}{2}(2+x)$

**9.3.9 (p. 494)**  $y_p = \frac{x^2e^{2x}}{2}(1+2x)$  **9.3.10 (p. 494)**  $y_p = x^2e^{3x}(2+x-x^2)$  **9.3.11 (p. 494)**  $y_p = x^2e^{4x}(2+x)$

**9.3.12 (p. 494)**  $y_p = \frac{x^3e^{x/2}}{48}(1+x)$  **9.3.13 (p. 494)**  $y_p = e^{-x}(1-2x+x^2)$  **9.3.14 (p. 494)**  $y_p = e^{2x}(1-x)$

**9.3.15 (p. 494)**  $y_p = e^{-2x}(1+x+x^2-x^3)$  **9.3.16 (p. 494)**  $y_p = \frac{e^x}{3}(1-x)$  **9.3.17 (p. 494)**  $y_p = e^x(1+x)^2$

**9.3.18 (p. 494)**  $y_p = xe^x(1+x^3)$  **9.3.19 (p. 494)**  $y_p = xe^x(2+x)$  **9.3.20 (p. 494)**  $y_p = \frac{xe^{2x}}{6}(1-x^2)$

**9.3.21 (p. 494)**  $y_p = 4xe^{-x/2}(1+x)$  **9.3.22 (p. 494)**  $y_p = \frac{xe^x}{6}(1+x^2)$

**9.3.23 (p. 494)**  $y_p = \frac{x^2e^{2x}}{6}(1+x+x^2)$  **9.3.24 (p. 494)**  $y_p = \frac{x^2e^{2x}}{6}(3+x+x^2)$  **9.3.25 (p. 494)**  $y_p = \frac{x^3e^x}{48}(2+x)$

**9.3.26 (p. 494)**  $y_p = \frac{x^3e^x}{6}(1+x)$  **9.3.27 (p. 495)**  $y_p = -\frac{x^3e^{-x}}{6}(1-x+x^2)$  **9.3.28 (p. 495)**  $y_p = \frac{x^3e^{2x}}{12}(2+x-x^2)$

**9.3.29 (p. 495)**  $y_p = e^{-x}[(1+x)\cos x + (2-x)\sin x]$  **9.3.30 (p. 495)**  $y_p = e^{-x}[(1-x)\cos 2x + (1+x)\sin 2x]$

**9.3.31 (p. 495)**  $y_p = e^{2x}[(1+x-x^2)\cos x + (1+2x)\sin x]$

**9.3.32 (p. 495)**  $y_p = \frac{e^x}{2}[(1+x)\cos 2x + (1-x+x^2)\sin 2x]$  **9.3.33 (p. 495)**  $y_p = \frac{x}{13}(8\cos 2x + 14\sin 2x)$

**9.3.34 (p. 495)**  $y_p = xe^x[(1+x)\cos x + (3+x)\sin x]$  **9.3.35 (p. 495)**  $y_p = \frac{xe^{2x}}{2}[(3-x)\cos 2x + \sin 2x]$

**9.3.36 (p. 495)**  $y_p = -\frac{xe^{3x}}{12}(x\cos 3x + \sin 3x)$  **9.3.37 (p. 495)**  $y_p = -\frac{e^x}{10}(\cos x + 7\sin x)$

**9.3.38 (p. 495)**  $y_p = \frac{e^x}{12}(\cos 2x - \sin 2x)$  **9.3.39 (p. 495)**  $y_p = xe^{2x}\cos 2x$

**9.3.40 (p. 495)**  $y_p = -\frac{e^{-x}}{2}[(1+x)\cos x + (2-x)\sin x]$  **9.3.41 (p. 495)**  $y_p = \frac{xe^{-x}}{10}(\cos x + 2\sin x)$

**9.3.42 (p. 495)**  $y_p = \frac{xe^x}{40}(3\cos 2x - \sin 2x)$  **9.3.43 (p. 495)**  $y_p = \frac{xe^{-2x}}{8}[(1-x)\cos 3x + (1+x)\sin 3x]$

**9.3.44 (p. 495)**  $y_p = -\frac{xe^x}{4}(1+x)\sin 2x$  **9.3.45 (p. 495)**  $y_p = \frac{x^2e^{-x}}{4}(\cos x - 2\sin x)$

**9.3.46 (p. 495)**  $y_p = -\frac{x^2e^{2x}}{32}(\cos 2x - \sin 2x)$  **9.3.47 (p. 495)**  $y_p = \frac{x^2e^{2x}}{8}(1+x)\sin x$

**9.3.48 (p. 495)**  $y_p = 2x^2e^x + xe^{2x} - \cos x$  **9.3.49 (p. 495)**  $y_p = e^{2x} + xe^x + 2x\cos x$

**9.3.50 (p. 495)**  $y_p = 2x + x^2 + 2xe^x - 3xe^{-x} + 4e^{3x}$

**9.3.51 (p. 495)**  $y_p = xe^x(\cos 2x - 2\sin 2x) + 2xe^{2x} + 1$  **9.3.52 (p. 495)**  $y_p = x^2e^{-2x}(1+2x) - \cos 2x + \sin 2x$

- 9.3.53 (p. 495)**  $y_p = 2x^2(1+x)e^{-x} + x \cos x - 2 \sin x$    **9.3.54 (p. 495)**  $y_p = 2xe^x + xe^{-x} + \cos x$   
**9.3.55 (p. 495)**  $y_p = \frac{xe^x}{6}(\cos x + \sin 2x)$    **9.3.56 (p. 495)**  $y_p = \frac{x^2}{54}[(2+2x)e^x + 3e^{-2x}]$   
**9.3.57 (p. 495)**  $y_p = \frac{x}{8} \sinh x \sin x$    **9.3.58 (p. 495)**  $y_p = x^3(1+x)e^{-x} + xe^{-2x}$   
**9.3.59 (p. 495)**  $y_p = xe^x(2x^2 + \cos x + \sin x)$    **9.3.60 (p. 495)**  $y = e^{2x}(1+x) + c_1e^{-x} + e^x(c_2 + c_3x)$   
**9.3.61 (p. 495)**  $y = e^{3x} \left(1 - x - \frac{x^2}{2}\right) + c_1e^x + e^{-x}(c_2 \cos x + c_3 \sin x)$   
**9.3.62 (p. 496)**  $y = xe^{2x}(1+x)^2 + c_1e^x + c_2e^{2x} + c_3e^{3x}$   
**9.3.63 (p. 496)**  $y = x^2e^{-x}(1-x)^2 + c_1 + e^{-x}(c_2 + c_3x)$   
**9.3.64 (p. 496)**  $y = \frac{x^3e^x}{24}(4+x) + e^x(c_1 + c_2x + c_3x^2)$   
**9.3.65 (p. 496)**  $y = \frac{x^2e^{-x}}{16}(1+2x-x^2) + e^x(c_1 + c_2x) + e^{-x}(c_3 + c_4x)$   
**9.3.66 (p. 496)**  $y = e^{-2x} \left[ \left(1 + \frac{x}{2}\right) \cos x + \left(\frac{3}{2} - 2x\right) \sin x \right] + c_1e^x + c_2e^{-x} + c_3e^{-2x}$   
**9.3.67 (p. 496)**  $y = -xe^{2x} \sin 2x + c_1 + c_2e^x + e^x(c_3 \cos x + c_4 \sin x)$   
**9.3.68 (p. 496)**  $y = -\frac{x^2e^x}{16}(1+x) \cos 2x + e^x[(c_1 + c_2x) \cos 2x + (c_3 + c_4x) \sin 2x]$   
**9.3.69 (p. 496)**  $y = (x^2 + 2)e^x - e^{-2x} + e^{3x}$    **9.3.70 (p. 496)**  $y = e^{-x}(1+x+x^2) + (1-x)e^x$   
**9.3.71 (p. 496)**  $y = \left(\frac{x^2}{12} + 16\right)xe^{-x/2} - e^x$    **9.3.72 (p. 496)**  $y = (2-x)(x^2+1)e^{-x} + \cos x - \sin x$   
**9.3.73 (p. 496)**  $y = (2-x) \cos x - (1-7x) \sin x + e^{-2x}$    **9.3.74 (p. 496)**  $2 + e^x[(1+x) \cos x - \sin x - 1]$

**Section 9.4 Answers, pp. 502–505**

- 9.4.1 (p. 502)**  $y_p = 2x^3$    **9.4.2 (p. 503)**  $y_p = \frac{8}{105}x^{7/2}e^{-x^2}$    **9.4.3 (p. 503)**  $y_p = x \ln |x|$   
**9.4.4 (p. 503)**  $y_p = -\frac{2(x^2+2)}{x}$    **9.4.5 (p. 503)**  $y_p = -\frac{xe^{-3x}}{64}$    **9.4.6 (p. 503)**  $y_p = -\frac{2x^2}{3}$   
**9.4.7 (p. 503)**  $y_p = -\frac{e^{-x}(x+1)}{x}$    **9.4.8 (p. 503)**  $y_p = 2x^2 \ln |x|$    **9.4.9 (p. 503)**  $y_p = x^2 + 1$   
**9.4.10 (p. 503)**  $y_p = \frac{2x^2+6}{3}$    **9.4.11 (p. 503)**  $y_p = \frac{x^2 \ln |x|}{3}$    **9.4.12 (p. 503)**  $y_p = -x^2 - 2$   
**9.4.13 (p. 503)**  $\frac{1}{4}x^3 \ln |x| - \frac{25}{48}x^3$    **9.4.14 (p. 503)**  $y_p = \frac{x^{5/2}}{4}$    **9.4.15 (p. 503)**  $y_p = \frac{x(12-x^2)}{6}$   
**9.4.16 (p. 503)**  $y_p = \frac{x^4 \ln |x|}{6}$    **9.4.17 (p. 503)**  $y_p = \frac{x^3e^x}{2}$    **9.4.18 (p. 503)**  $y_p = x^2 \ln |x|$   
**9.4.19 (p. 503)**  $y_p = \frac{xe^x}{2}$    **9.4.20 (p. 503)**  $y_p = \frac{3xe^x}{2}$    **9.4.21 (p. 503)**  $y_p = -x^3$   
**9.4.22 (p. 503)**  $y = -x(\ln x)^2 + 3x + x^3 - 2x \ln x$    **9.4.23 (p. 503)**  $y = \frac{x^3}{2}(\ln |x|)^2 + x^2 - x^3 + 2x^3 \ln |x|$   
**9.4.24 (p. 503)**  $y = -\frac{1}{2}(3x+1)xe^x - 3e^x - e^{2x} + 4xe^{-x}$    **9.4.25 (p. 503)**  $y = \frac{3}{2}x^4(\ln x)^2 + 3x - x^4 + 2x^4 \ln x$   
**9.4.26 (p. 503)**  $y = -\frac{x^4+12}{6} + 3x - x^2 + 2e^x$    **9.4.27 (p. 503)**  $y = \left(\frac{x^2}{3} - \frac{x}{2}\right) \ln |x| + 4x - 2x^2$   
**9.4.28 (p. 504)**  $y = -\frac{xe^x(1+3x)}{2} + \frac{x+1}{2} - \frac{e^x}{4} + \frac{e^{3x}}{2}$    **9.4.29 (p. 504)**  $y = -8x + 2x^2 - 2x^3 + 2e^x - e^{-x}$   
**9.4.30 (p. 504)**  $y = 3x^2 \ln x - 7x^2$    **9.4.31 (p. 504)**  $y = \frac{3(4x^2+9)}{2} + \frac{x}{2} - \frac{e^x}{2} + \frac{e^{-x}}{2} + \frac{e^{2x}}{4}$

**9.4.32 (p. 504)**  $y = x \ln x + x - \sqrt{x} + \frac{1}{x} + \frac{1}{\sqrt{x}}$ . **9.4.33 (p. 504)**  $y = x^3 \ln |x| + x - 2x^3 + \frac{1}{x} - \frac{1}{x^2}$   
**9.4.35 (p. 505)**  $y_p = \int_{x_0}^x \frac{e^{(x-t)} - 3e^{-(x-t)} + 2e^{-2(x-t)}}{6} F(t) dt$  **9.4.36 (p. 505)**  $y_p = \int_{x_0}^x \frac{(x-t)^2(2x+t)}{6xt^3} F(t) dt$   
**9.4.37 (p. 505)**  $y_p = \int_{x_0}^x \frac{xe^{(x-t)} - x^2 + x(t-1)}{t^4} F(t) dt$  **9.4.38 (p. 505)**  $y_p = \int_{x_0}^x \frac{x^2 - t(t-2) - 2te^{(x-t)}}{2x(t-1)^2} F(t) dt$   
**9.4.39 (p. 505)**  $y_p = \int_{x_0}^x \frac{e^{2(x-t)} - 2e^{(x-t)} + 2e^{-(x-t)} - e^{-2(x-t)}}{12} F(t) dt$   
**9.4.40 (p. 505)**  $y_p = \int_{x_0}^x \frac{(x-t)^3}{6x} F(t) dt$   
**9.4.41 (p. 505)**  $y_p = \int_{x_0}^x \frac{(x+t)(x-t)^3}{12x^2t^3} F(t) dt$   
**9.4.42 (p. 505)**  $y_p = \int_{x_0}^x \frac{e^{2(x-t)}(1+2t) + e^{-2(x-t)}(1-2t) - 4x^2 + 4t^2 - 2}{32t^2} F(t) dt$

**Section 10.1 Answers, pp. 514–515**

**10.1.1 (p. 514)**  $Q'_1 = 2 - \frac{1}{10}Q_1 + \frac{1}{25}Q_2$  **10.1.2 (p. 514)**  $Q'_1 = 12 - \frac{5}{100+2t}Q_1 + \frac{1}{100+3t}Q_2$   
 $Q'_2 = 6 + \frac{3}{50}Q_1 - \frac{1}{20}Q_2$   $Q'_2 = 5 + \frac{1}{50+t}Q_1 - \frac{4}{100+3t}Q_2$

**10.1.3 (p. 514)**  $m_1y''_1 = -(c_1 + c_2)y'_1 + c_2y'_2 - (k_1 + k_2)y_1 + k_2y_2 + F_1$   
 $m_2y''_2 = (c_2 - c_3)y'_1 - (c_2 + c_3)y'_2 + c_3y'_3 + (k_2 - k_3)y_1 - (k_2 + k_3)y_2 + k_3y_3 + F_2$   
 $m_3y''_3 = c_3y'_1 + c_3y'_2 - c_3y'_3 + k_3y_1 + k_3y_2 - k_3y_3 + F_3$

**10.1.4 (p. 515)**  $x'' = -\frac{\alpha}{m}x' + \frac{gR^2x}{(x^2 + y^2 + z^2)^{3/2}}$   $y'' = -\frac{\alpha}{m}y' + \frac{gR^2y}{(x^2 + y^2 + z^2)^{3/2}}$

$z'' = -\frac{\alpha}{m}z' + \frac{gR^2z}{(x^2 + y^2 + z^2)^{3/2}}$

**10.1.5 (p. 515)** (a)  $x'_1 = x_2$   $x'_2 = x_3$   $x'_3 = f(t, x_1, y_1, y_2)$   $y'_1 = y_2$   $y'_2 = g(t, y_1, y_2)$   
 (b)  $u'_1 = f(t, u_1, v_1, v_2, w_2)$   $v'_1 = v_2$   $v'_2 = g(t, u_1, v_1, v_2, w_1)$   $w'_1 = w_2$   $w'_2 = h(t, u_1, v_1, v_2, w_1, w_2)$

(c)  $y'_1 = y_2$   $y'_2 = y_3$   $y'_3 = f(t, y_1, y_2, y_3)$  (d)  $y'_1 = y_2$   $y'_2 = y_3$   $y'_3 = y_4$   $y'_4 = f(t, y_1)$

(e)  $x'_1 = x_2$   $x'_2 = f(t, x_1, y_1)$   $y'_1 = y_2$   $y'_2 = g(t, x_1, y_1)$

**10.1.6 (p. 515)**  $x' = x_1$   $x'_1 = -\frac{gR^2x}{(x^2 + y^2 + z^2)^{3/2}}$   $y' = y_1$   $y'_1 = -\frac{gR^2y}{(x^2 + y^2 + z^2)^{3/2}}$   $z' = z_1$   $z'_1 = -\frac{gR^2z}{(x^2 + y^2 + z^2)^{3/2}}$

**Section 10.2 Answers, pp. 518–521**

$$10.2.1 \text{ (p. 518) (a) } \mathbf{y}' = \begin{bmatrix} 2 & 4 \\ 4 & 2 \end{bmatrix} \mathbf{y} \quad \text{(b) } \mathbf{y}' = \begin{bmatrix} -2 & -2 \\ -5 & 1 \end{bmatrix} \mathbf{y}$$

$$\text{(c) } \mathbf{y}' = \begin{bmatrix} -4 & -10 \\ 3 & 7 \end{bmatrix} \mathbf{y} \quad \text{(d) } \mathbf{y}' = \begin{bmatrix} 2 & 1 \\ 1 & 2 \end{bmatrix} \mathbf{y}$$

$$10.2.2 \text{ (p. 518) (a) } \mathbf{y}' = \begin{bmatrix} -1 & 2 & 3 \\ 0 & 1 & 6 \\ 0 & 0 & -2 \end{bmatrix} \mathbf{y} \quad \text{(b) } \mathbf{y}' = \begin{bmatrix} 0 & 2 & 2 \\ 2 & 0 & 2 \\ 2 & 2 & 0 \end{bmatrix} \mathbf{y}$$

$$\text{(c) } \mathbf{y}' = \begin{bmatrix} -1 & 2 & 2 \\ 2 & -1 & 2 \\ 2 & 2 & -1 \end{bmatrix} \mathbf{y} \quad \text{(d) } \mathbf{y}' = \begin{bmatrix} 3 & -1 & -1 \\ -2 & 3 & 2 \\ 4 & -1 & -2 \end{bmatrix} \mathbf{y}$$

$$10.2.3 \text{ (p. 518) (a) } \mathbf{y}' = \begin{bmatrix} 1 & 1 \\ -2 & 4 \end{bmatrix} \mathbf{y}, \mathbf{y}(0) = \begin{bmatrix} 1 \\ 0 \end{bmatrix} \quad \text{(b) } \mathbf{y}' = \begin{bmatrix} 5 & 3 \\ -1 & 1 \end{bmatrix} \mathbf{y}, \mathbf{y}(0) = \begin{bmatrix} 9 \\ -5 \end{bmatrix}$$

$$10.2.4 \text{ (p. 519) (a) } \mathbf{y}' = \begin{bmatrix} 6 & 4 & 4 \\ -7 & -2 & -1 \\ 7 & 4 & 3 \end{bmatrix} \mathbf{y}, \mathbf{y}(0) = \begin{bmatrix} 3 \\ -6 \\ 4 \end{bmatrix}$$

$$\text{(b) } \mathbf{y}' = \begin{bmatrix} 8 & 7 & 7 \\ -5 & -6 & -9 \\ 5 & 7 & 10 \end{bmatrix} \mathbf{y}, \mathbf{y}(0) = \begin{bmatrix} 2 \\ -4 \\ 3 \end{bmatrix}$$

$$10.2.5 \text{ (p. 519) (a) } \mathbf{y}' = \begin{bmatrix} -3 & 2 \\ -5 & 3 \end{bmatrix} + \begin{bmatrix} 3-2t \\ 6-3t \end{bmatrix} \quad \text{(b) } \mathbf{y}' = \begin{bmatrix} 3 & 1 \\ -1 & 1 \end{bmatrix} \mathbf{y} + \begin{bmatrix} -5e^t \\ e^t \end{bmatrix}$$

$$10.2.10 \text{ (p. 521) (a) } \frac{d}{dt} Y^2 = Y'Y + YY'$$

$$\text{(b) } \frac{d}{dt} Y^n = Y'Y^{n-1} + Y Y' Y^{n-2} + Y^2 Y' Y^{n-3} + \cdots + Y^{n-1} Y' = \sum_{r=0}^{n-1} Y^r Y' Y^{n-r-1}$$

$$10.2.13 \text{ (p. 521) } B = (P' + PA)P^{-1}.$$

Section 10.3 Answers, pp. 525–529

$$10.3.2 \text{ (p. 525) } \mathbf{y}' = \begin{bmatrix} 0 & 1 \\ -\frac{P_2(x)}{P_0(x)} & -\frac{P_1(x)}{P_0(x)} \end{bmatrix} \mathbf{y} \quad 10.3.3 \text{ (p. 526) } \mathbf{y}' = \begin{bmatrix} 0 & 1 & \cdots & 0 \\ \vdots & \vdots & \ddots & \vdots \\ 0 & 0 & \cdots & 1 \\ -\frac{P_n(x)}{P_0(x)} & -\frac{P_{n-1}(x)}{P_0(x)} & \cdots & -\frac{P_1(x)}{P_0(x)} \end{bmatrix} \mathbf{y}$$

$$10.3.7 \text{ (p. 527) (b) } \mathbf{y} = \begin{bmatrix} 3e^{6t} - 6e^{-2t} \\ 3e^{6t} + 6e^{-2t} \end{bmatrix} \quad \text{(c) } \mathbf{y} = \frac{1}{2} \begin{bmatrix} e^{6t} + e^{-2t} & e^{6t} - e^{-2t} \\ e^{6t} - e^{-2t} & e^{6t} + e^{-2t} \end{bmatrix} \mathbf{k}$$

$$10.3.8 \text{ (p. 528) (b) } \mathbf{y} = \begin{bmatrix} 6e^{-4t} + 4e^{3t} \\ 6e^{-4t} - 10e^{3t} \end{bmatrix} \quad \text{(c) } \mathbf{y} = \frac{1}{7} \begin{bmatrix} 5e^{-4t} + 2e^{3t} & 2e^{-4t} - 2e^{3t} \\ 5e^{-4t} - 5e^{3t} & 2e^{-4t} + 5e^{3t} \end{bmatrix} \mathbf{k}$$

$$10.3.9 \text{ (p. 528) (b) } \mathbf{y} = \begin{bmatrix} -15e^{2t} - 4e^t \\ 9e^{2t} + 2e^t \end{bmatrix} \quad \text{(c) } \mathbf{y} = \begin{bmatrix} -5e^{2t} + 6e^t & -10e^{2t} + 10e^t \\ 3e^{2t} - 3e^t & 6e^{2t} - 5e^t \end{bmatrix} \mathbf{k}$$

$$10.3.10 \text{ (p. 528) (b) } \mathbf{y} = \begin{bmatrix} 5e^{3t} - 3e^t \\ 5e^{3t} + 3e^t \end{bmatrix} \quad \text{(c) } \mathbf{y} = \frac{1}{2} \begin{bmatrix} e^{3t} + e^t & e^{3t} - e^t \\ e^{3t} - e^t & e^{3t} + e^t \end{bmatrix} \mathbf{k}$$

$$10.3.11 \text{ (p. 528) (b) } \mathbf{y} = \begin{bmatrix} e^{2t} - 2e^{3t} + 3e^{-t} \\ 2e^{3t} - 9e^{-t} \\ e^{2t} - 2e^{3t} + 21e^{-t} \end{bmatrix} \quad \text{(c) } \mathbf{y} = \frac{1}{6} \begin{bmatrix} 4e^{2t} + 3e^{3t} - e^{-t} & 6e^{2t} - 6e^{3t} & 2e^{2t} - 3e^{3t} + e^{-t} \\ -3e^{3t} + 3e^{-t} & 6e^{3t} & 3e^{3t} - 3e^{-t} \\ 4e^{2t} + 3e^{3t} - 7e^{-t} & 6e^{2t} - 6e^{3t} & 2e^{2t} - 3e^{3t} + 7e^{-t} \end{bmatrix} \mathbf{k}$$

$$10.3.12 \text{ (p. 528) (b) } \mathbf{y} = \frac{1}{3} \begin{bmatrix} -e^{-2t} + e^{4t} \\ -10e^{-2t} + e^{4t} \\ 11e^{-2t} + e^{4t} \end{bmatrix} \quad \text{(c) } \mathbf{y} = \frac{1}{3} \begin{bmatrix} 2e^{-2t} + e^{4t} & -e^{-2t} + e^{4t} & -e^{-2t} + e^{4t} \\ -e^{-2t} + e^{4t} & 2e^{-2t} + e^{4t} & -e^{-2t} + e^{4t} \\ -e^{-2t} + e^{4t} & -e^{-2t} + e^{4t} & 2e^{-2t} + e^{4t} \end{bmatrix} \mathbf{k}$$

$$10.3.13 \text{ (p. 528) (b) } \mathbf{y} = \begin{bmatrix} 3e^t + 3e^{-t} - e^{-2t} \\ 3e^t + 2e^{-2t} \\ -e^{-2t} \end{bmatrix} \quad \text{(c) } \mathbf{y} = \begin{bmatrix} e^{-t} & e^t - e^{-t} & 2e^t - 3e^{-t} + e^{-2t} \\ 0 & e^t & 2e^t - 2e^{-2t} \\ 0 & 0 & e^{-2t} \end{bmatrix} \mathbf{k}$$

10.3.14 (p. 529)  $YZ^{-1}$  and  $ZY^{-1}$

**Section 10.4 Answers, pp. 539–541**

$$10.4.1 \text{ (p. 539) } \mathbf{y} = c_1 \begin{bmatrix} 1 \\ 1 \end{bmatrix} e^{3t} + c_2 \begin{bmatrix} 1 \\ -1 \end{bmatrix} e^{-t} \quad 10.4.2 \text{ (p. 539) } \mathbf{y} = c_1 \begin{bmatrix} 1 \\ 1 \end{bmatrix} e^{-t/2} + c_2 \begin{bmatrix} -1 \\ 1 \end{bmatrix} e^{-2t}$$

$$10.4.3 \text{ (p. 539) } \mathbf{y} = c_1 \begin{bmatrix} -3 \\ 1 \end{bmatrix} e^{-t} + c_2 \begin{bmatrix} -1 \\ 2 \end{bmatrix} e^{-2t} \quad 10.4.4 \text{ (p. 539) } \mathbf{y} = c_1 \begin{bmatrix} 2 \\ 1 \end{bmatrix} e^{-3t} + c_2 \begin{bmatrix} -2 \\ 1 \end{bmatrix} e^t$$

$$10.4.5 \text{ (p. 539) } \mathbf{y} = c_1 \begin{bmatrix} 1 \\ 1 \end{bmatrix} e^{-2t} + c_2 \begin{bmatrix} -4 \\ 1 \end{bmatrix} e^{3t} \quad 10.4.6 \text{ (p. 539) } \mathbf{y} = c_1 \begin{bmatrix} 3 \\ 2 \end{bmatrix} e^{2t} + c_2 \begin{bmatrix} 1 \\ 1 \end{bmatrix} e^t$$

$$10.4.7 \text{ (p. 539) } \mathbf{y} = c_1 \begin{bmatrix} -3 \\ 1 \end{bmatrix} e^{-5t} + c_2 \begin{bmatrix} -1 \\ 1 \end{bmatrix} e^{-3t}$$

$$10.4.8 \text{ (p. 539) } \mathbf{y} = c_1 \begin{bmatrix} 1 \\ 2 \\ 1 \end{bmatrix} e^{-3t} + c_2 \begin{bmatrix} -1 \\ -4 \\ 1 \end{bmatrix} e^{-t} + c_3 \begin{bmatrix} -1 \\ -1 \\ 1 \end{bmatrix} e^{2t}$$

$$10.4.9 \text{ (p. 539) } \mathbf{y} = c_1 \begin{bmatrix} 2 \\ 1 \\ 2 \end{bmatrix} e^{-16t} + c_2 \begin{bmatrix} -1 \\ 2 \\ 0 \end{bmatrix} e^{2t} + c_3 \begin{bmatrix} -1 \\ 0 \\ 1 \end{bmatrix} e^{2t}$$

$$10.4.10 \text{ (p. 539) } \mathbf{y} = c_1 \begin{bmatrix} -2 \\ -4 \\ 3 \end{bmatrix} e^t + c_2 \begin{bmatrix} -1 \\ 1 \\ 0 \end{bmatrix} e^{-2t} + c_3 \begin{bmatrix} -7 \\ -5 \\ 4 \end{bmatrix} e^{2t}$$

$$10.4.11 \text{ (p. 539) } \mathbf{y} = c_1 \begin{bmatrix} -1 \\ -1 \\ 1 \end{bmatrix} e^{-2t} + c_2 \begin{bmatrix} -1 \\ -2 \\ 1 \end{bmatrix} e^{-3t} + c_3 \begin{bmatrix} -2 \\ -6 \\ 3 \end{bmatrix} e^{-5t}$$

$$10.4.12 \text{ (p. 539) } \mathbf{y} = c_1 \begin{bmatrix} 11 \\ 7 \\ 1 \end{bmatrix} e^{3t} + c_2 \begin{bmatrix} 1 \\ 2 \\ 1 \end{bmatrix} e^{-2t} + c_3 \begin{bmatrix} 1 \\ 1 \\ 1 \end{bmatrix} e^{-t}$$

$$10.4.13 \text{ (p. 539) } \mathbf{y} = c_1 \begin{bmatrix} 4 \\ -1 \\ 1 \end{bmatrix} e^{-4t} + c_2 \begin{bmatrix} -1 \\ -1 \\ 1 \end{bmatrix} e^{6t} + c_3 \begin{bmatrix} -1 \\ 0 \\ 1 \end{bmatrix} e^{4t}$$

$$10.4.14 \text{ (p. 539) } \mathbf{y} = c_1 \begin{bmatrix} 1 \\ 1 \\ 5 \end{bmatrix} e^{-5t} + c_2 \begin{bmatrix} -1 \\ 0 \\ 1 \end{bmatrix} e^{5t} + c_3 \begin{bmatrix} 1 \\ 1 \\ 0 \end{bmatrix} e^{5t}$$

$$10.4.15 \text{ (p. 539) } \mathbf{y} = c_1 \begin{bmatrix} 1 \\ -1 \\ 2 \end{bmatrix} + c_2 \begin{bmatrix} -1 \\ 0 \\ 3 \end{bmatrix} e^{6t} + c_3 \begin{bmatrix} 1 \\ 3 \\ 0 \end{bmatrix} e^{6t}$$

$$10.4.16 \text{ (p. 540) } \mathbf{y} = - \begin{bmatrix} 2 \\ 6 \end{bmatrix} e^{5t} + \begin{bmatrix} 4 \\ 2 \end{bmatrix} e^{-5t} \quad 10.4.17 \text{ (p. 540) } \mathbf{y} = \begin{bmatrix} 2 \\ -4 \end{bmatrix} e^{t/2} + \begin{bmatrix} -2 \\ 1 \end{bmatrix} e^t$$

$$10.4.18 \text{ (p. 540) } \mathbf{y} = \begin{bmatrix} 7 \\ 7 \end{bmatrix} e^{9t} - \begin{bmatrix} 2 \\ 4 \end{bmatrix} e^{-3t} \quad 10.4.19 \text{ (p. 540) } \mathbf{y} = \begin{bmatrix} 3 \\ 9 \end{bmatrix} e^{5t} - \begin{bmatrix} 4 \\ 2 \end{bmatrix} e^{-5t}$$

$$10.4.20 \text{ (p. 540)} \quad \mathbf{y} = \begin{bmatrix} 5 \\ 5 \\ 0 \end{bmatrix} e^{t/2} + \begin{bmatrix} 0 \\ 0 \\ 1 \end{bmatrix} e^{t/2} + \begin{bmatrix} -1 \\ 2 \\ 0 \end{bmatrix} e^{-t/2} \quad 10.4.21 \text{ (p. 540)} \quad \mathbf{y} = \begin{bmatrix} 3 \\ 3 \\ 3 \end{bmatrix} e^t + \begin{bmatrix} -2 \\ -2 \\ 2 \end{bmatrix} e^{-t}$$

$$10.4.22 \text{ (p. 540)} \quad \mathbf{y} = \begin{bmatrix} 2 \\ -2 \\ 2 \end{bmatrix} e^t - \begin{bmatrix} 3 \\ 0 \\ 3 \end{bmatrix} e^{-2t} + \begin{bmatrix} 1 \\ 1 \\ 0 \end{bmatrix} e^{3t}$$

$$10.4.23 \text{ (p. 540)} \quad \mathbf{y} = - \begin{bmatrix} 1 \\ 2 \\ 1 \end{bmatrix} e^t + \begin{bmatrix} 4 \\ 2 \\ 4 \end{bmatrix} e^{-t} + \begin{bmatrix} 1 \\ 1 \\ 0 \end{bmatrix} e^{2t}$$

$$10.4.24 \text{ (p. 540)} \quad \mathbf{y} = \begin{bmatrix} -2 \\ -2 \\ 2 \end{bmatrix} e^{2t} - \begin{bmatrix} 0 \\ 3 \\ 0 \end{bmatrix} e^{-2t} + \begin{bmatrix} 4 \\ 12 \\ 4 \end{bmatrix} e^{4t}$$

$$10.4.25 \text{ (p. 540)} \quad \mathbf{y} = \begin{bmatrix} -1 \\ -1 \\ 1 \end{bmatrix} e^{-6t} + \begin{bmatrix} 2 \\ -2 \\ 2 \end{bmatrix} e^{2t} + \begin{bmatrix} 7 \\ -7 \\ -7 \end{bmatrix} e^{4t}$$

$$10.4.26 \text{ (p. 540)} \quad \mathbf{y} = \begin{bmatrix} 1 \\ 4 \\ 4 \end{bmatrix} e^{-t} + \begin{bmatrix} 6 \\ 6 \\ -2 \end{bmatrix} e^{2t} \quad 10.4.27 \text{ (p. 540)} \quad \mathbf{y} = \begin{bmatrix} 4 \\ -2 \\ 2 \end{bmatrix} + \begin{bmatrix} 3 \\ -9 \\ 6 \end{bmatrix} e^{4t} + \begin{bmatrix} -1 \\ 1 \\ -1 \end{bmatrix} e^{2t}$$

10.4.29 (p. 541) Half lines of  $L_1 : y_2 = y_1$  and  $L_2 : y_2 = -y_1$  are trajectories other trajectories are asymptotically tangent to  $L_1$  as  $t \rightarrow -\infty$  and asymptotically tangent to  $L_2$  as  $t \rightarrow \infty$ .

10.4.30 (p. 541) Half lines of  $L_1 : y_2 = -2y_1$  and  $L_2 : y_2 = -y_1/3$  are trajectories other trajectories are asymptotically parallel to  $L_1$  as  $t \rightarrow -\infty$  and asymptotically tangent to  $L_2$  as  $t \rightarrow \infty$ .

10.4.31 (p. 541) Half lines of  $L_1 : y_2 = y_1/3$  and  $L_2 : y_2 = -y_1$  are trajectories other trajectories are asymptotically tangent to  $L_1$  as  $t \rightarrow -\infty$  and asymptotically parallel to  $L_2$  as  $t \rightarrow \infty$ .

10.4.32 (p. 541) Half lines of  $L_1 : y_2 = y_1/2$  and  $L_2 : y_2 = -y_1$  are trajectories other trajectories are asymptotically tangent to  $L_1$  as  $t \rightarrow -\infty$  and asymptotically tangent to  $L_2$  as  $t \rightarrow \infty$ .

10.4.33 (p. 541) Half lines of  $L_1 : y_2 = -y_1/4$  and  $L_2 : y_2 = -y_1$  are trajectories other trajectories are asymptotically tangent to  $L_1$  as  $t \rightarrow -\infty$  and asymptotically parallel to  $L_2$  as  $t \rightarrow \infty$ .

10.4.34 (p. 541) Half lines of  $L_1 : y_2 = -y_1$  and  $L_2 : y_2 = 3y_1$  are trajectories other trajectories are asymptotically parallel to  $L_1$  as  $t \rightarrow -\infty$  and asymptotically tangent to  $L_2$  as  $t \rightarrow \infty$ .

10.4.36 (p. 541) Points on  $L_2 : y_2 = y_1$  are trajectories of constant solutions. The trajectories of nonconstant solutions are half-lines on either side of  $L_1$ , parallel to  $\begin{bmatrix} 1 \\ -1 \end{bmatrix}$ , traversed toward  $L_1$ .

10.4.37 (p. 541) Points on  $L_1 : y_2 = -y_1/3$  are trajectories of constant solutions. The trajectories of nonconstant solutions are half-lines on either side of  $L_1$ , parallel to  $\begin{bmatrix} -1 \\ 2 \end{bmatrix}$ , traversed away from  $L_1$ .

10.4.38 (p. 541) Points on  $L_1 : y_2 = y_1/3$  are trajectories of constant solutions. The trajectories of nonconstant solutions are half-lines on either side of  $L_1$ , parallel to  $\begin{bmatrix} 1 \\ -1 \end{bmatrix}$ ,  $\begin{bmatrix} 1 \\ 1 \end{bmatrix}$ ,  $-1$ , traversed away from  $L_1$ .

10.4.39 (p. 541) Points on  $L_1 : y_2 = y_1/2$  are trajectories of constant solutions. The trajectories

of nonconstant solutions are half-lines on either side of  $L_1$ , parallel to  $\begin{bmatrix} 1 \\ -1 \end{bmatrix}$ ,  $L_1$ .

10.4.40 (p. 541) Points on  $L_2 : y_2 = -y_1$  are trajectories of constant solutions. The trajectories

of nonconstant solutions are half-lines on either side of  $L_2$ , parallel to  $\begin{bmatrix} -4 \\ 1 \end{bmatrix}$ , traversed toward  $L_1$ .

10.4.41 (p. 541) Points on  $L_1 : y_2 = 3y_1$  are trajectories of constant solutions. The trajectories

of nonconstant solutions are half-lines on either side of  $L_1$ , parallel to  $\begin{bmatrix} 1 \\ -1 \end{bmatrix}$ , traversed away from  $L_1$ .

**Section 10.5 Answers, pp. 554–556**

10.5.1 (p. 554)  $\mathbf{y} = c_1 \begin{bmatrix} 2 \\ 1 \end{bmatrix} e^{5t} + c_2 \left( \begin{bmatrix} -1 \\ 0 \end{bmatrix} e^{5t} + \begin{bmatrix} 2 \\ 1 \end{bmatrix} te^{5t} \right)$ .

10.5.2 (p. 554)  $\mathbf{y} = c_1 \begin{bmatrix} 1 \\ 1 \end{bmatrix} e^{-t} + c_2 \left( \begin{bmatrix} 1 \\ 0 \end{bmatrix} e^{-t} + \begin{bmatrix} 1 \\ 1 \end{bmatrix} te^{-t} \right)$

10.5.3 (p. 554)  $\mathbf{y} = c_1 \begin{bmatrix} -2 \\ 1 \end{bmatrix} e^{-9t} + c_2 \left( \begin{bmatrix} -1 \\ 0 \end{bmatrix} e^{-9t} + \begin{bmatrix} -2 \\ 1 \end{bmatrix} te^{-9t} \right)$

10.5.4 (p. 554)  $\mathbf{y} = c_1 \begin{bmatrix} -1 \\ 1 \end{bmatrix} e^{2t} + c_2 \left( \begin{bmatrix} -1 \\ 0 \end{bmatrix} e^{2t} + \begin{bmatrix} -1 \\ 1 \end{bmatrix} te^{2t} \right)$

10.5.5 (p. 554)  $c_1 \begin{bmatrix} -2 \\ 1 \end{bmatrix} + c_2 \left( \begin{bmatrix} -1 \\ 0 \end{bmatrix} \frac{e^{-2t}}{3} + \begin{bmatrix} -2 \\ 1 \end{bmatrix} te^{-2t} \right)$

10.5.6 (p. 554)  $\mathbf{y} = c_1 \begin{bmatrix} 3 \\ 2 \end{bmatrix} e^{-4t} + c_2 \left( \begin{bmatrix} -1 \\ 0 \end{bmatrix} \frac{e^{-4t}}{2} + \begin{bmatrix} 3 \\ 2 \end{bmatrix} te^{-4t} \right)$

10.5.7 (p. 554)  $\mathbf{y} = c_1 \begin{bmatrix} 4 \\ 3 \end{bmatrix} e^{-t} + c_2 \left( \begin{bmatrix} -1 \\ 0 \end{bmatrix} \frac{e^{-t}}{3} + \begin{bmatrix} 4 \\ 3 \end{bmatrix} te^{-t} \right)$

10.5.8 (p. 554)  $\mathbf{y} = c_1 \begin{bmatrix} -1 \\ -1 \\ 2 \end{bmatrix} + c_2 \begin{bmatrix} 1 \\ 1 \\ 2 \end{bmatrix} e^{4t} + c_3 \left( \begin{bmatrix} 0 \\ 1 \\ 0 \end{bmatrix} \frac{e^{4t}}{2} + \begin{bmatrix} 1 \\ 1 \\ 2 \end{bmatrix} te^{4t} \right)$

10.5.9 (p. 554)  $\mathbf{y} = c_1 \begin{bmatrix} -1 \\ 1 \\ 1 \end{bmatrix} e^t + c_2 \begin{bmatrix} 1 \\ -1 \\ 1 \end{bmatrix} e^{-t} + c_3 \left( \begin{bmatrix} 0 \\ 3 \\ 0 \end{bmatrix} e^{-t} + \begin{bmatrix} 1 \\ -1 \\ 1 \end{bmatrix} te^{-t} \right)$ .

10.5.10 (p. 554)  $\mathbf{y} = c_1 \begin{bmatrix} 0 \\ 1 \\ 1 \end{bmatrix} e^{2t} + c_2 \begin{bmatrix} 1 \\ 0 \\ 1 \end{bmatrix} e^{-2t} + c_3 \left( \begin{bmatrix} 1 \\ 1 \\ 0 \end{bmatrix} \frac{e^{-2t}}{2} + \begin{bmatrix} 1 \\ 0 \\ 1 \end{bmatrix} te^{-2t} \right)$

10.5.11 (p. 554)  $\mathbf{y} = c_1 \begin{bmatrix} -2 \\ -3 \\ 1 \end{bmatrix} e^{2t} + c_2 \begin{bmatrix} 0 \\ -1 \\ 1 \end{bmatrix} e^{4t} + c_3 \left( \begin{bmatrix} 1 \\ 0 \\ 0 \end{bmatrix} \frac{e^{4t}}{2} + \begin{bmatrix} 0 \\ -1 \\ 1 \end{bmatrix} te^{4t} \right)$

10.5.12 (p. 554)  $\mathbf{y} = c_1 \begin{bmatrix} -1 \\ -1 \\ 1 \end{bmatrix} e^{-2t} + c_2 \begin{bmatrix} 1 \\ 1 \\ 1 \end{bmatrix} e^{4t} + c_3 \left( \begin{bmatrix} 1 \\ 0 \\ 0 \end{bmatrix} \frac{e^{4t}}{2} + \begin{bmatrix} 1 \\ 1 \\ 1 \end{bmatrix} te^{4t} \right)$ .

10.5.13 (p. 554)  $\mathbf{y} = \begin{bmatrix} 6 \\ 2 \end{bmatrix} e^{-7t} - \begin{bmatrix} 8 \\ 4 \end{bmatrix} te^{-7t}$  10.5.14 (p. 554)  $\mathbf{y} = \begin{bmatrix} 5 \\ 8 \end{bmatrix} e^{3t} - \begin{bmatrix} 12 \\ 16 \end{bmatrix} te^{3t}$

$$10.5.15 \text{ (p. 554)} \quad \mathbf{y} = \begin{bmatrix} 2 \\ 3 \end{bmatrix} e^{-5t} - \begin{bmatrix} 8 \\ 4 \end{bmatrix} t e^{-5t} \quad 10.5.16 \text{ (p. 554)} \quad \mathbf{y} = \begin{bmatrix} 3 \\ 1 \end{bmatrix} e^{5t} - \begin{bmatrix} 12 \\ 6 \end{bmatrix} t e^{5t}$$

$$10.5.17 \text{ (p. 554)} \quad \mathbf{y} = \begin{bmatrix} 0 \\ 2 \end{bmatrix} e^{-4t} + \begin{bmatrix} 6 \\ 6 \end{bmatrix} t e^{-4t}$$

$$10.5.18 \text{ (p. 554)} \quad \mathbf{y} = \begin{bmatrix} 4 \\ 8 \\ -6 \end{bmatrix} e^t + \begin{bmatrix} 2 \\ -3 \\ -1 \end{bmatrix} e^{-2t} + \begin{bmatrix} -1 \\ 1 \\ 0 \end{bmatrix} t e^{-2t}$$

$$10.5.19 \text{ (p. 554)} \quad \mathbf{y} = \begin{bmatrix} 3 \\ 3 \\ 6 \end{bmatrix} e^{2t} - \begin{bmatrix} 9 \\ 5 \\ 6 \end{bmatrix} + \begin{bmatrix} 2 \\ 2 \\ 0 \end{bmatrix} t$$

$$10.5.20 \text{ (p. 554)} \quad \mathbf{y} = - \begin{bmatrix} 2 \\ 0 \\ 2 \end{bmatrix} e^{-3t} + \begin{bmatrix} -4 \\ 9 \\ 1 \end{bmatrix} e^t - \begin{bmatrix} 0 \\ 4 \\ 4 \end{bmatrix} t e^t$$

$$10.5.21 \text{ (p. 555)} \quad \mathbf{y} = \begin{bmatrix} -2 \\ 2 \\ 2 \end{bmatrix} e^{4t} + \begin{bmatrix} 0 \\ -1 \\ 1 \end{bmatrix} e^{2t} + \begin{bmatrix} 3 \\ -3 \\ 3 \end{bmatrix} t e^{2t}$$

$$10.5.22 \text{ (p. 555)} \quad \mathbf{y} = - \begin{bmatrix} 1 \\ 1 \\ 0 \end{bmatrix} e^{-4t} + \begin{bmatrix} -3 \\ 2 \\ -3 \end{bmatrix} e^{8t} + \begin{bmatrix} 8 \\ 0 \\ -8 \end{bmatrix} t e^{8t}$$

$$10.5.23 \text{ (p. 555)} \quad \mathbf{y} = \begin{bmatrix} 3 \\ 6 \\ 3 \end{bmatrix} e^{4t} - \begin{bmatrix} 3 \\ 4 \\ 1 \end{bmatrix} + \begin{bmatrix} 8 \\ 4 \\ 4 \end{bmatrix} t$$

$$10.5.24 \text{ (p. 555)} \quad \mathbf{y} = c_1 \begin{bmatrix} 0 \\ 1 \\ 1 \end{bmatrix} e^{6t} + c_2 \left( \begin{bmatrix} -1 \\ 1 \\ 0 \end{bmatrix} \frac{e^{6t}}{4} + \begin{bmatrix} 0 \\ 1 \\ 1 \end{bmatrix} t e^{6t} \right) \\ + c_3 \left( \begin{bmatrix} 1 \\ 1 \\ 0 \end{bmatrix} \frac{e^{6t}}{8} + \begin{bmatrix} -1 \\ 1 \\ 0 \end{bmatrix} \frac{t e^{6t}}{4} + \begin{bmatrix} 0 \\ 1 \\ 1 \end{bmatrix} \frac{t^2 e^{6t}}{2} \right)$$

$$10.5.25 \text{ (p. 555)} \quad \mathbf{y} = c_1 \begin{bmatrix} -1 \\ 1 \\ 1 \end{bmatrix} e^{3t} + c_2 \left( \begin{bmatrix} 1 \\ 0 \\ 0 \end{bmatrix} \frac{e^{3t}}{2} + \begin{bmatrix} -1 \\ 1 \\ 1 \end{bmatrix} t e^{3t} \right) \\ + c_3 \left( \begin{bmatrix} 1 \\ 2 \\ 0 \end{bmatrix} \frac{e^{3t}}{36} + \begin{bmatrix} 1 \\ 0 \\ 0 \end{bmatrix} \frac{t e^{3t}}{2} + \begin{bmatrix} -1 \\ 1 \\ 1 \end{bmatrix} \frac{t^2 e^{3t}}{2} \right)$$

$$10.5.26 \text{ (p. 555)} \quad \mathbf{y} = c_1 \begin{bmatrix} 0 \\ -1 \\ 1 \end{bmatrix} e^{-2t} + c_2 \left( \begin{bmatrix} -1 \\ 1 \\ 0 \end{bmatrix} e^{-2t} + \begin{bmatrix} 0 \\ -1 \\ 1 \end{bmatrix} t e^{-2t} \right) \\ + c_3 \left( \begin{bmatrix} 3 \\ -2 \\ 0 \end{bmatrix} \frac{e^{-2t}}{4} + \begin{bmatrix} -1 \\ 1 \\ 0 \end{bmatrix} t e^{-2t} + \begin{bmatrix} 0 \\ -1 \\ 1 \end{bmatrix} \frac{t^2 e^{-2t}}{2} \right)$$



$$10.5.27 \text{ (p. 555)} \quad \mathbf{y} = c_1 \begin{bmatrix} 0 \\ 1 \\ 1 \end{bmatrix} e^{2t} + c_2 \left( \begin{bmatrix} 1 \\ 1 \\ 0 \end{bmatrix} \frac{e^{2t}}{2} + \begin{bmatrix} 0 \\ 1 \\ 1 \end{bmatrix} t e^{2t} \right) \\ + c_3 \left( \begin{bmatrix} -1 \\ 1 \\ 0 \end{bmatrix} \frac{e^{2t}}{8} + \begin{bmatrix} 1 \\ 1 \\ 0 \end{bmatrix} \frac{t e^{2t}}{2} + \begin{bmatrix} 0 \\ 1 \\ 1 \end{bmatrix} \frac{t^2 e^{2t}}{2} \right)$$

$$10.5.28 \text{ (p. 555)} \quad \mathbf{y} = c_1 \begin{bmatrix} -2 \\ 1 \\ 2 \end{bmatrix} e^{-6t} + c_2 \left( - \begin{bmatrix} 6 \\ 1 \\ 0 \end{bmatrix} \frac{e^{-6t}}{6} + \begin{bmatrix} -2 \\ 1 \\ 2 \end{bmatrix} t e^{-6t} \right) \\ + c_3 \left( - \begin{bmatrix} 12 \\ 1 \\ 0 \end{bmatrix} \frac{e^{-6t}}{36} - \begin{bmatrix} 6 \\ 1 \\ 0 \end{bmatrix} \frac{t e^{-6t}}{6} + \begin{bmatrix} -2 \\ 1 \\ 2 \end{bmatrix} \frac{t^2 e^{-6t}}{2} \right).$$

$$10.5.29 \text{ (p. 555)} \quad \mathbf{y} = c_1 \begin{bmatrix} -4 \\ 0 \\ 1 \end{bmatrix} e^{-3t} + c_2 \begin{bmatrix} 6 \\ 1 \\ 0 \end{bmatrix} e^{-3t} + c_3 \left( \begin{bmatrix} 1 \\ 0 \\ 0 \end{bmatrix} e^{-3t} + \begin{bmatrix} 2 \\ 1 \\ 1 \end{bmatrix} t e^{-3t} \right)$$

$$10.5.30 \text{ (p. 555)} \quad \mathbf{y} = c_1 \begin{bmatrix} -1 \\ 0 \\ 1 \end{bmatrix} e^{-3t} + c_2 \begin{bmatrix} 0 \\ 1 \\ 0 \end{bmatrix} e^{-3t} + c_3 \left( \begin{bmatrix} 1 \\ 0 \\ 0 \end{bmatrix} e^{-3t} + \begin{bmatrix} -1 \\ -1 \\ 1 \end{bmatrix} t e^{-3t} \right)$$

$$10.5.31 \text{ (p. 555)} \quad \mathbf{y} = c_1 \begin{bmatrix} 2 \\ 0 \\ 1 \end{bmatrix} e^{-t} + c_2 \begin{bmatrix} -3 \\ 2 \\ 0 \end{bmatrix} e^{-t} + c_3 \left( \begin{bmatrix} 1 \\ 0 \\ 0 \end{bmatrix} \frac{e^{-t}}{2} + \begin{bmatrix} -1 \\ 2 \\ 1 \end{bmatrix} t e^{-t} \right)$$

$$10.5.32 \text{ (p. 555)} \quad \mathbf{y} = c_1 \begin{bmatrix} -1 \\ 1 \\ 0 \end{bmatrix} e^{-2t} + c_2 \begin{bmatrix} 0 \\ 0 \\ 1 \end{bmatrix} e^{-2t} + c_3 \left( \begin{bmatrix} -1 \\ 0 \\ 0 \end{bmatrix} e^{-2t} + \begin{bmatrix} 1 \\ -1 \\ 1 \end{bmatrix} t e^{-2t} \right)$$

**Section 10.6 Answers, pp. 565–568**

$$10.6.1 \text{ (p. 565)} \quad \mathbf{y} = c_1 e^{2t} \begin{bmatrix} 3 \cos t + \sin t \\ 5 \cos t \end{bmatrix} + c_2 e^{2t} \begin{bmatrix} 3 \sin t - \cos t \\ 5 \sin t \end{bmatrix}.$$

$$10.6.2 \text{ (p. 565)} \quad \mathbf{y} = c_1 e^{-t} \begin{bmatrix} 5 \cos 2t + \sin 2t \\ 13 \cos 2t \end{bmatrix} + c_2 e^{-t} \begin{bmatrix} 5 \sin 2t - \cos 2t \\ 13 \sin 2t \end{bmatrix}.$$

$$10.6.3 \text{ (p. 565)} \quad \mathbf{y} = c_1 e^{3t} \begin{bmatrix} \cos 2t + \sin 2t \\ 2 \cos 2t \end{bmatrix} + c_2 e^{3t} \begin{bmatrix} \sin 2t - \cos 2t \\ 2 \sin 2t \end{bmatrix}.$$

$$10.6.4 \text{ (p. 565)} \quad \mathbf{y} = c_1 e^{2t} \begin{bmatrix} \cos 3t - \sin 3t \\ \cos 3t \end{bmatrix} + c_2 e^{2t} \begin{bmatrix} \sin 3t + \cos 3t \\ \sin 3t \end{bmatrix}.$$

$$10.6.5 \text{ (p. 566)} \quad \mathbf{y} = c_1 \begin{bmatrix} -1 \\ -1 \\ 2 \end{bmatrix} e^{-2t} + c_2 e^{4t} \begin{bmatrix} \cos 2t - \sin 2t \\ \cos 2t + \sin 2t \\ 2 \cos 2t \end{bmatrix} + c_3 e^{4t} \begin{bmatrix} \sin 2t + \cos 2t \\ \sin 2t - \cos 2t \\ 2 \sin 2t \end{bmatrix}.$$

$$10.6.6 \text{ (p. 566)} \quad \mathbf{y} = c_1 \begin{bmatrix} -1 \\ -1 \\ 1 \end{bmatrix} e^{-t} + c_2 e^{-2t} \begin{bmatrix} \cos 2t - \sin 2t \\ -\cos 2t - \sin 2t \\ 2 \cos 2t \end{bmatrix} + c_3 e^{-2t} \begin{bmatrix} \sin 2t + \cos 2t \\ -\sin 2t + \cos 2t \\ 2 \sin 2t \end{bmatrix}$$

$$10.6.7 \text{ (p. 566)} \quad \mathbf{y} = c_1 \begin{bmatrix} 1 \\ 1 \\ 1 \end{bmatrix} e^{2t} + c_2 e^t \begin{bmatrix} -\sin t \\ \sin t \\ \cos t \end{bmatrix} + c_3 e^t \begin{bmatrix} \cos t \\ -\cos t \\ \sin t \end{bmatrix}$$

$$10.6.8 \text{ (p. 566)} \quad \mathbf{y} = c_1 \begin{bmatrix} -1 \\ 1 \\ 1 \end{bmatrix} e^t + c_2 e^{-t} \begin{bmatrix} -\sin 2t - \cos 2t \\ 2 \cos 2t \\ 2 \cos 2t \end{bmatrix} + c_3 e^{-t} \begin{bmatrix} \cos 2t - \sin 2t \\ 2 \sin 2t \\ 2 \sin 2t \end{bmatrix}$$

$$10.6.9 \text{ (p. 566)} \quad \mathbf{y} = c_1 e^{3t} \begin{bmatrix} \cos 6t - 3 \sin 6t \\ 5 \cos 6t \end{bmatrix} + c_2 e^{3t} \begin{bmatrix} \sin 6t + 3 \cos 6t \\ 5 \sin 6t \end{bmatrix}$$

$$10.6.10 \text{ (p. 566)} \quad \mathbf{y} = c_1 e^{2t} \begin{bmatrix} \cos t - 3 \sin t \\ 2 \cos t \end{bmatrix} + c_2 e^{2t} \begin{bmatrix} \sin t + 3 \cos t \\ 2 \sin t \end{bmatrix}$$

$$10.6.11 \text{ (p. 566)} \quad \mathbf{y} = c_1 e^{2t} \begin{bmatrix} 3 \sin 3t - \cos 3t \\ 5 \cos 3t \end{bmatrix} + c_2 e^{2t} \begin{bmatrix} -3 \cos 3t - \sin 3t \\ 5 \sin 3t \end{bmatrix}$$

$$10.6.12 \text{ (p. 566)} \quad \mathbf{y} = c_1 e^{2t} \begin{bmatrix} \sin 4t - 8 \cos 4t \\ 5 \cos 4t \end{bmatrix} + c_2 e^{2t} \begin{bmatrix} -\cos 4t - 8 \sin 4t \\ 5 \sin 4t \end{bmatrix}$$

$$10.6.13 \text{ (p. 566)} \quad \mathbf{y} = c_1 \begin{bmatrix} -1 \\ 1 \\ 1 \end{bmatrix} e^{-2t} + c_2 e^t \begin{bmatrix} \sin t \\ -\cos t \\ \cos t \end{bmatrix} + c_3 e^t \begin{bmatrix} -\cos t \\ -\sin t \\ \sin t \end{bmatrix}$$

$$10.6.14 \text{ (p. 566)} \quad \mathbf{y} = c_1 \begin{bmatrix} 2 \\ 2 \\ 1 \end{bmatrix} e^{-2t} + c_2 e^{2t} \begin{bmatrix} -\cos 3t - \sin 3t \\ -\sin 3t \\ \cos 3t \end{bmatrix} + c_3 e^{2t} \begin{bmatrix} -\sin 3t + \cos 3t \\ \cos 3t \\ \sin 3t \end{bmatrix}$$

$$10.6.15 \text{ (p. 566)} \quad \mathbf{y} = c_1 \begin{bmatrix} 1 \\ 2 \\ 1 \end{bmatrix} e^{3t} + c_2 e^{6t} \begin{bmatrix} -\sin 3t \\ \sin 3t \\ \cos 3t \end{bmatrix} + c_3 e^{6t} \begin{bmatrix} \cos 3t \\ -\cos 3t \\ \sin 3t \end{bmatrix}$$

$$10.6.16 \text{ (p. 566)} \quad \mathbf{y} = c_1 \begin{bmatrix} 1 \\ 1 \\ 1 \end{bmatrix} e^t + c_2 e^t \begin{bmatrix} 2 \cos t - 2 \sin t \\ \cos t - \sin t \\ 2 \cos t \end{bmatrix} + c_3 e^t \begin{bmatrix} 2 \sin t + 2 \cos t \\ \cos t + \sin t \\ 2 \sin t \end{bmatrix}$$

$$10.6.17 \text{ (p. 566)} \quad \mathbf{y} = e^t \begin{bmatrix} 5 \cos 3t + \sin 3t \\ 2 \cos 3t + 3 \sin 3t \end{bmatrix} \quad 10.6.18 \text{ (p. 566)} \quad \mathbf{y} = e^{4t} \begin{bmatrix} 5 \cos 6t + 5 \sin 6t \\ \cos 6t - 3 \sin 6t \end{bmatrix}$$

$$10.6.19 \text{ (p. 566)} \quad \mathbf{y} = e^t \begin{bmatrix} 17 \cos 3t - \sin 3t \\ 7 \cos 3t + 3 \sin 3t \end{bmatrix} \quad 10.6.20 \text{ (p. 566)} \quad \mathbf{y} = e^{t/2} \begin{bmatrix} \cos(t/2) + \sin(t/2) \\ -\cos(t/2) + 2 \sin(t/2) \end{bmatrix}$$

$$10.6.21 \text{ (p. 566)} \quad \mathbf{y} = \begin{bmatrix} 1 \\ -1 \\ 2 \end{bmatrix} e^t + e^{4t} \begin{bmatrix} 3 \cos t + \sin t \\ \cos t - 3 \sin t \\ 4 \cos t - 2 \sin t \end{bmatrix}$$

$$10.6.22 \text{ (p. 566)} \quad \mathbf{y} = \begin{bmatrix} 4 \\ 4 \\ 2 \end{bmatrix} e^{8t} + e^{2t} \begin{bmatrix} 4 \cos 2t + 8 \sin 2t \\ -6 \sin 2t + 2 \cos 2t \\ 3 \cos 2t + \sin 2t \end{bmatrix}$$

$$10.6.23 \text{ (p. 566)} \quad \mathbf{y} = \begin{bmatrix} 0 \\ 3 \\ 3 \end{bmatrix} e^{-4t} + e^{4t} \begin{bmatrix} 15 \cos 6t + 10 \sin 6t \\ 14 \cos 6t - 8 \sin 6t \\ 7 \cos 6t - 4 \sin 6t \end{bmatrix}$$

$$10.6.24 \text{ (p. 566)} \quad \mathbf{y} = \begin{bmatrix} 6 \\ -3 \\ 3 \end{bmatrix} e^{8t} + \begin{bmatrix} 10 \cos 4t - 4 \sin 4t \\ 17 \cos 4t - \sin 4t \\ 3 \cos 4t - 7 \sin 4t \end{bmatrix}$$

$$10.6.29 \text{ (p. 567)} \quad \mathbf{U} = \frac{1}{\sqrt{2}} \begin{bmatrix} -1 \\ 1 \end{bmatrix}, \quad \mathbf{V} = \frac{1}{\sqrt{2}} \begin{bmatrix} 1 \\ 1 \end{bmatrix}$$

$$10.6.30 \text{ (p. 567)} \quad \mathbf{U} \approx \begin{bmatrix} .5257 \\ .8507 \end{bmatrix}, \quad \mathbf{V} \approx \begin{bmatrix} -.8507 \\ .5257 \end{bmatrix}$$

10.6.31 (p. 567)  $U \approx \begin{bmatrix} .8507 \\ .5257 \end{bmatrix}$ ,

$V \approx \begin{bmatrix} -.5257 \\ .8507 \end{bmatrix}$  10.6.32 (p. 567)  $U \approx \begin{bmatrix} -.9732 \\ .2298 \end{bmatrix}$ ,  $V \approx \begin{bmatrix} .2298 \\ .9732 \end{bmatrix}$

10.6.33 (p. 567)  $U \approx \begin{bmatrix} .5257 \\ .8507 \end{bmatrix}$ ,  $V \approx \begin{bmatrix} -.8507 \\ .5257 \end{bmatrix}$

10.6.34 (p. 567)  $U \approx \begin{bmatrix} -.5257 \\ .8507 \end{bmatrix}$ ,  $V \approx \begin{bmatrix} .8507 \\ .5257 \end{bmatrix}$

10.6.35 (p. 568)  $U \approx \begin{bmatrix} -.8817 \\ .4719 \end{bmatrix}$ ,  $V \approx \begin{bmatrix} .4719 \\ .8817 \end{bmatrix}$

10.6.36 (p. 568)  $U \approx \begin{bmatrix} .8817 \\ .4719 \end{bmatrix}$ ,  $V \approx \begin{bmatrix} -.4719 \\ .8817 \end{bmatrix}$

10.6.37 (p. 568)  $U = \begin{bmatrix} 0 \\ 1 \end{bmatrix}$ ,  $V = \begin{bmatrix} -1 \\ 0 \end{bmatrix}$

10.6.38 (p. 568)  $U = \begin{bmatrix} 0 \\ 1 \end{bmatrix}$ ,  $V = \begin{bmatrix} 1 \\ 0 \end{bmatrix}$

10.6.39 (p. 568)  $U = \frac{1}{\sqrt{2}} \begin{bmatrix} 1 \\ 1 \end{bmatrix}$ ,  $V = \frac{1}{\sqrt{2}} \begin{bmatrix} -1 \\ 1 \end{bmatrix}$

10.6.40 (p. 568)  $U \approx \begin{bmatrix} .5257 \\ .8507 \end{bmatrix}$ ,  $V \approx \begin{bmatrix} -.8507 \\ .5257 \end{bmatrix}$

Section 10.7 Answers, pp. 575–577

10.7.1 (p. 575)  $\begin{bmatrix} 5e^{4t} + e^{-3t}(2+8t) \\ -e^{4t} - e^{-3t}(1-4t) \end{bmatrix}$  10.7.2 (p. 575)  $\begin{bmatrix} 13e^{3t} + 3e^{-3t} \\ -e^{3t} - 11e^{-3t} \end{bmatrix}$  10.7.3 (p. 575)  $\frac{1}{9} \begin{bmatrix} 7-6t \\ -11+3t \end{bmatrix}$

10.7.4 (p. 575)  $\begin{bmatrix} 5-3e^t \\ -6+5e^t \end{bmatrix}$

10.7.5 (p. 575)  $\begin{bmatrix} e^{-5t}(3+6t) + e^{-3t}(3-2t) \\ -e^{-5t}(3+2t) - e^{-3t}(1-2t) \end{bmatrix}$  10.7.6 (p. 575)  $\begin{bmatrix} t \\ 0 \end{bmatrix}$  10.7.7 (p. 575)  $-\frac{1}{6} \begin{bmatrix} 2-6t \\ 7+6t \\ 1-12t \end{bmatrix}$

10.7.8 (p. 575)  $-\frac{1}{6} \begin{bmatrix} 3e^t + 4 \\ 6e^t - 4 \\ 10 \end{bmatrix}$

10.7.9 (p. 575)  $\frac{1}{18} \begin{bmatrix} e^t(1+12t) - e^{-5t}(1+6t) \\ -2e^t(1-6t) - e^{-5t}(1-12t) \\ e^t(1+12t) - e^{-5t}(1+6t) \end{bmatrix}$  10.7.10 (p. 575)  $\frac{1}{3} \begin{bmatrix} 2e^t \\ e^t \\ 2e^t \end{bmatrix}$  10.7.11 (p. 575)  $\begin{bmatrix} t \sin t \\ 0 \end{bmatrix}$

10.7.12 (p. 575)  $-\begin{bmatrix} t^2 \\ 2t \end{bmatrix}$

10.7.13 (p. 575)  $(t-1)(\ln|t-1|+t) \begin{bmatrix} 1 \\ -1 \end{bmatrix}$  10.7.14 (p. 575)  $\frac{1}{9} \begin{bmatrix} 5e^{2t} - e^{-3t} \\ e^{3t} - 5e^{-2t} \end{bmatrix}$  10.7.15 (p. 576)  $\frac{1}{4t} \begin{bmatrix} 2t^3 \ln|t| + t^3(t+2) \\ 2 \ln|t| + 3t - 2 \end{bmatrix}$

10.7.16 (p. 576)  $\frac{1}{2} \begin{bmatrix} te^{-t}(t+2) + (t^3-2) \\ te^t(t-2) + (t^3+2) \end{bmatrix}$  10.7.17 (p. 576)  $-\begin{bmatrix} t \\ t \\ t \end{bmatrix}$  10.7.18 (p. 576)  $\frac{1}{4} \begin{bmatrix} -3e^t \\ 1 \\ e^{-t} \end{bmatrix}$

10.7.19 (p. 576)  $\begin{bmatrix} 2t^2+t \\ t \\ -t \end{bmatrix}$  10.7.20 (p. 576)  $\frac{e^t}{4t} \begin{bmatrix} 2t+1 \\ 2t-1 \\ 2t+1 \end{bmatrix}$

10.7.22 (p. 576) (a)  $y' = \begin{bmatrix} 0 & 1 & \cdots & 0 \\ 0 & 0 & \cdots & 0 \\ \vdots & \vdots & \ddots & \vdots \\ 0 & 0 & \cdots & 1 \\ -P_n(t)/P_0(t) & -P_{n-1}(t)/P_0(t) & \cdots & -P_1(t)/P_0(t) \end{bmatrix} y + \begin{bmatrix} 0 \\ 0 \\ \vdots \\ F(t)/P_0(t) \end{bmatrix}$ .

$$(b) \begin{bmatrix} y_1 & y_2 & \cdots & y_n \\ y'_1 & y'_2 & \cdots & y'_n \\ \vdots & \vdots & \ddots & \vdots \\ y_1^{(n-1)} & y_2^{(n-1)} & \cdots & y_n^{(n-1)} \end{bmatrix}$$

**Section 11.1 Answers, pp. 585–586**

$$11.1.2 \text{ (p. 585)} \quad \lambda_n = n^2, y_n = \sin nx, n = 1, 2, 3, \dots$$

$$11.1.3 \text{ (p. 585)} \quad \lambda_0 = 0, y_0 = 1; \lambda_n = n^2, y_n = \cos nx, n = 1, 2, 3, \dots$$

$$11.1.4 \text{ (p. 585)} \quad \lambda_n = \frac{(2n-1)^2}{4}, y_n = \sin \frac{(2n-1)x}{2}, n = 1, 2, 3, \dots,$$

$$11.1.5 \text{ (p. 585)} \quad \lambda_n = \frac{(2n-1)^2}{4}, y_n = \cos \frac{(2n-1)x}{2}, n = 1, 2, 3, \dots$$

$$11.1.6 \text{ (p. 585)} \quad \lambda_0 = 0, y_0 = 1, \lambda_n = n^2, y_{1n} = \cos nx, y_{2n} = \sin nx, n = 1, 2, 3, \dots$$

$$11.1.7 \text{ (p. 585)} \quad \lambda_n = n^2\pi^2, y_n = \cos n\pi x, n = 1, 2, 3, \dots$$

$$11.1.8 \text{ (p. 585)} \quad \lambda_n = \frac{(2n-1)^2\pi^2}{4}, y_n = \cos \frac{(2n-1)\pi x}{2}, n = 1, 2, 3, \dots$$

$$11.1.9 \text{ (p. 585)} \quad \lambda_n = n^2\pi^2, y_n = \sin n\pi x, n = 1, 2, 3, \dots$$

$$11.1.10 \text{ (p. 585)} \quad \lambda_0 = 0, y_0 = 1, \lambda_n = n^2\pi^2, y_{1n} = \cos n\pi x, y_{2n} = \sin n\pi x, n = 1, 2, 3, \dots$$

$$11.1.11 \text{ (p. 585)} \quad \lambda_n = \frac{(2n-1)^2\pi^2}{4}, y_n = \sin \frac{(2n-1)\pi x}{2}, n = 1, 2, 3, \dots$$

$$11.1.12 \text{ (p. 585)} \quad \lambda_0 = 0, y_0 = 1, \lambda_n = \frac{n^2\pi^2}{4}, y_{1n} = \cos \frac{n\pi x}{2}, y_{2n} = \sin \frac{n\pi x}{2}, n = 1, 2, 3, \dots$$

$$11.1.13 \text{ (p. 585)} \quad \lambda_n = \frac{n^2\pi^2}{4}, y_n = \sin \frac{n\pi x}{2}, n = 1, 2, 3, \dots$$

$$11.1.14 \text{ (p. 585)} \quad \lambda_n = \frac{(2n-1)^2\pi^2}{36}, y_n = \cos \frac{(2n-1)\pi x}{6}, n = 1, 2, 3, \dots$$

$$11.1.15 \text{ (p. 585)} \quad \lambda_n = (2n-1)^2\pi^2, y_n = \sin(2n-1)\pi x, n = 1, 2, 3, \dots$$

$$11.1.16 \text{ (p. 585)} \quad \lambda_n = \frac{n^2\pi^2}{25}, y_n = \cos \frac{n\pi x}{5}, n = 1, 2, 3, \dots$$

$$11.1.23 \text{ (p. 586)} \quad \lambda_n = 4n^2\pi^2/L^2, y_n = \sin \frac{2n\pi x}{L}, n = 1, 2, 3, \dots$$

$$11.1.24 \text{ (p. 586)} \quad \lambda_n = n^2\pi^2/L^2, y_n = \cos \frac{n\pi x}{L}, n = 1, 2, 3, \dots$$

$$11.1.25 \text{ (p. 586)} \quad \lambda_n = 4n^2\pi^2/L^2, y_n = \sin \frac{2n\pi x}{L}, n = 1, 2, 3, \dots$$

$$11.1.26 \text{ (p. 586)} \quad \lambda_n = n^2\pi^2/L^2, y_n = \cos \frac{n\pi x}{L}, n = 1, 2, 3, \dots$$

**Section 11.2 Answers, pp. 598–602**

$$11.2.2 \text{ (p. 598)} \quad F(x) = 2 + \frac{2}{\pi} \sum_{n=1}^{\infty} \frac{(-1)^n}{n} \sin n\pi x; \quad F(x) = \begin{cases} 2, & x = -1, \\ 2-x, & -1 < x < 1, \\ 2, & x = 1 \end{cases}$$

$$11.2.3 \text{ (p. 598)} \quad F(x) = -\pi^2 - 12 \sum_{n=1}^{\infty} \frac{(-1)^n}{n^2} \cos nx - 4 \sum_{n=1}^{\infty} \frac{(-1)^n}{n} \sin nx;$$

$$F(x) = \begin{cases} -3\pi^2, & x = -\pi, \\ 2x - 3x^2, & -\pi < x < \pi, \\ -3\pi^2, & x = \pi \end{cases}$$

$$11.2.4 \text{ (p. 598)} \quad F(x) = -\frac{12}{\pi^2} \sum_{n=1}^{\infty} (-1)^n \frac{\cos n\pi x}{n^2}; \quad F(x) = 1 - 3x^2 \quad -1 \leq x \leq 1$$

$$11.2.5 \text{ (p. 598)} \quad F(x) = \frac{2}{\pi} - \frac{4}{\pi} \sum_{n=1}^{\infty} \frac{1}{4n^2 - 1} \cos 2nx; \quad F(x) = |\sin x|, \quad -\pi \leq x \leq \pi$$

$$11.2.6 \text{ (p. 599)} \quad F(x) = -\frac{1}{2} \sin x + 2 \sum_{n=2}^{\infty} (-1)^n \frac{n}{n^2 - 1} \sin nx; \quad F(x) = x \cos x, \quad -\pi \leq x \leq \pi$$

$$11.2.7 \text{ (p. 599)} \quad F(x) = -\frac{2}{\pi} + \frac{\pi}{2} \cos x - \frac{4}{\pi} \sum_{n=1}^{\infty} \frac{4n^2 + 1}{(4n^2 - 1)^2} \cos 2nx;$$

$$F(x) = |x| \cos x, \quad -\pi \leq x \leq \pi$$

$$11.2.8 \text{ (p. 599)} \quad F(x) = 1 - \frac{1}{2} \cos x - 2 \sum_{n=2}^{\infty} \frac{(-1)^n}{n^2 - 1} \cos nx; \quad F(x) = x \sin x, \quad -\pi \leq x \leq \pi$$

$$11.2.9 \text{ (p. 599)} \quad F(x) = \frac{\pi}{2} \sin x - \frac{16}{\pi} \sum_{n=1}^{\infty} \frac{n}{(4n^2 - 1)^2} \sin 2nx; \quad F(x) = |x| \sin x, \quad -\pi \leq x \leq \pi$$

$$11.2.10 \text{ (p. 599)} \quad F(x) = \frac{1}{\pi} + \frac{1}{2} \cos \pi x - \frac{2}{\pi} \sum_{n=1}^{\infty} \frac{(-1)^n}{4n^2 - 1} \cos 2n\pi x; \quad F(x) = f(x), \quad -1 \leq x \leq 1$$

$$11.2.11 \text{ (p. 599)} \quad F(x) = \frac{1}{4\pi} \sin \pi x - \frac{8}{\pi^2} \sum_{n=1}^{\infty} (-1)^n \frac{n}{(4n^2 - 1)^2} \sin 2n\pi x;$$

$$-\frac{1}{4\pi} \sum_{n=1}^{\infty} \frac{(-1)^n}{n(n+1)} \sin(2n+1)\pi x \quad F(x) = f(x), \quad -1 \leq x \leq 1$$

$$11.2.12 \text{ (p. 599)} \quad F(x) = \frac{1}{2} \sin \pi x - \frac{4}{\pi} \sum_{n=1}^{\infty} (-1)^n \frac{n}{4n^2 - 1} \sin 2n\pi x; \quad F(x) = \begin{cases} 0, & -1 \leq x < \frac{1}{2}, \\ -\frac{1}{2}, & x = -\frac{1}{2}, \\ \sin \pi x, & -\frac{1}{2} < x < \frac{1}{2}, \\ \frac{1}{2}, & x = \frac{1}{2}, \\ 0, & \frac{1}{2} < x \leq 1 \end{cases}$$

$$11.2.13 \text{ (p. 599)} \quad F(x) = \frac{1}{\pi} + \frac{1}{\pi} \cos \pi x - \frac{2}{\pi} \sum_{n=2}^{\infty} \frac{1}{n^2 - 1} \left(1 - n \sin \frac{n\pi}{2}\right) \cos n\pi x;$$

$$F(x) = \begin{cases} 0, & -1 \leq x < \frac{1}{2}, \\ \frac{1}{2}, & x = -1, \\ |\sin \pi x|, & -\frac{1}{2} < x < \frac{1}{2}, \\ \frac{1}{2}, & x = 1, \\ 0, & \frac{1}{2} < x \leq 1 \end{cases}$$

$$11.2.14 \text{ (p. 599)} \quad F(x) = \frac{1}{\pi^2} + \frac{1}{4\pi} \cos \pi x + \frac{2}{\pi^2} \sum_{n=1}^{\infty} (-1)^n \frac{4n^2 + 1}{(4n^2 - 1)^2} \cos 2n\pi x$$

$$+ \frac{1}{4\pi} \sum_{n=1}^{\infty} (-1)^n \frac{2n+1}{n(n+1)} \cos(2n+1)\pi x;$$

$$F(x) = \begin{cases} 0, & -1 \leq x < \frac{1}{2}, \\ \frac{1}{4}, & x = -\frac{1}{2}, \\ x \sin \pi x, & -\frac{1}{2} < x < \frac{1}{2}, \\ \frac{1}{4}, & x = \frac{1}{2}, \\ 0, & \frac{1}{2} < x \leq 1, \end{cases}$$

$$11.2.15 \text{ (p. 599)} \quad F(x) = 1 - \frac{8}{\pi^2} \sum_{n=0}^{\infty} \frac{1}{(2n+1)^2} \cos \frac{(2n+1)\pi x}{4} - \frac{4}{\pi} \sum_{n=1}^{\infty} \frac{(-1)^n}{n} \sin \frac{n\pi x}{4};$$

$$F(x) = \begin{cases} 2, & x = -4, \\ 0, & -4 < x < 0, \\ x, & 0 \leq x < 4, \\ 2, & x = 4 \end{cases}$$

$$11.2.16 \text{ (p. 599)} \quad F(x) = \frac{1}{2} + \frac{1}{\pi} \sum_{n=1}^{\infty} \frac{1}{n} \sin 2n\pi x + \frac{8}{\pi^3} \sum_{n=0}^{\infty} \frac{1}{(2n+1)^3} \sin(2n+1)\pi x;$$

$$F(x) = \begin{cases} \frac{1}{2}, & x = -1, \\ x^2, & -1 < x < 0, \\ \frac{1}{2}, & x = 0, \\ 1 - x^2, & 0 < x < 1, \\ \frac{1}{2}, & x = 1 \end{cases}$$

$$11.2.17 \text{ (p. 599)} \quad F(x) = \frac{3}{4} + \frac{1}{\pi} \sum_{n=1}^{\infty} \frac{1}{n} \sin \frac{n\pi x}{2} \cos \frac{n\pi x}{2} + \frac{3}{\pi} \sum_{n=1}^{\infty} \frac{1}{n} \left( \cos n\pi - \cos \frac{n\pi}{2} \right) \sin \frac{n\pi x}{2}$$

$$11.2.18 \text{ (p. 599)} \quad F(x) = \frac{5}{2} + \frac{3}{\pi} \sum_{n=1}^{\infty} \frac{1}{n} \sin \frac{2n\pi x}{3} \cos \frac{n\pi x}{3} + \frac{1}{\pi} \sum_{n=1}^{\infty} \frac{1}{n} \left( \cos n\pi - \cos \frac{2n\pi}{3} \right) \sin \frac{n\pi x}{3}$$

$$11.2.20 \text{ (p. 599)} \quad F(x) = \frac{\sinh \pi}{\pi} \left( 1 + 2 \sum_{n=1}^{\infty} \frac{(-1)^n}{n^2 + 1} \cos nx - 2 \sum_{n=1}^{\infty} \frac{(-1)^n n}{n^2 + 1} \sin nx \right)$$

$$11.2.21 \text{ (p. 599)} \quad F(x) = -\pi \cos x - \frac{1}{2} \sin x + 2 \sum_{n=2}^{\infty} (-1)^n \frac{n}{n^2 - 1} \sin nx$$

$$11.2.22 \text{ (p. 600)} \quad F(x) = 1 - \frac{1}{2} \cos x - \pi \sin x - 2 \sum_{n=2}^{\infty} \frac{(-1)^n}{n^2 - 1} \cos nx$$

$$11.2.23 \text{ (p. 600)} \quad F(x) = -\frac{2 \sin k\pi}{\pi} \sum_{n=1}^{\infty} (-1)^n \frac{n}{n^2 - k^2} \sin nx$$

$$11.2.24 \text{ (p. 600)} \quad F(x) = \frac{\sin k\pi}{\pi} \left[ \frac{1}{k} - 2k \sum_{n=1}^{\infty} \frac{(-1)^n}{n^2 - k^2} \cos nx \right]$$

### Section 11.3 Answers, pp. 613–616

$$11.3.1 \text{ (p. 613)} \quad C(x) = \frac{L^2}{3} + \frac{4L^2}{\pi^2} \sum_{n=1}^{\infty} \frac{(-1)^n}{n^2} \cos \frac{n\pi x}{L}$$

$$11.3.2 \text{ (p. 613)} \quad C(x) = \frac{1}{2} + \frac{4}{\pi^2} \sum_{n=1}^{\infty} \frac{1}{(2n-1)^2} \cos(2n-1)\pi x$$

$$11.3.3 \text{ (p. 613)} \quad C(x) = -\frac{2L^2}{3} + \frac{4L^2}{\pi^2} \sum_{n=1}^{\infty} \frac{1}{n^2} \cos \frac{n\pi x}{L}$$

$$11.3.4 \text{ (p. 613)} \quad C(x) = \frac{1 - \cos k\pi}{k\pi} - \frac{2k}{\pi} \sum_{n=1}^{\infty} \frac{[1 - (-1)^n \cos k\pi]}{n^2 - k^2} \cos nx.$$

$$11.3.5 \text{ (p. 613)} \quad C(x) = \frac{1}{2} - \frac{2}{\pi} \sum_{n=1}^{\infty} \frac{(-1)^n}{2n-1} \cos \frac{(2n-1)\pi x}{L}$$

$$11.3.6 \text{ (p. 613)} \quad C(x) = -\frac{2L^2}{3} + \frac{4L^2}{\pi^2} \sum_{n=1}^{\infty} \frac{(-1)^n}{n^2} \cos \frac{n\pi x}{L}$$

$$11.3.7 \text{ (p. 613)} \quad C(x) = \frac{1}{3} + \frac{4}{\pi^2} \sum_{n=1}^{\infty} \frac{1}{n^2} \cos n\pi x$$

$$11.3.8 \text{ (p. 613)} \quad C(x) = \frac{e^\pi - 1}{\pi} + \frac{2}{\pi} \sum_{n=1}^{\infty} \frac{[(-1)^n e^\pi - 1]}{(n^2 + 1)} \cos nx$$

$$11.3.9 \text{ (p. 613)} \quad C(x) = \frac{L^2}{6} - \frac{L^2}{\pi^2} \sum_{n=1}^{\infty} \frac{1}{n^2} \cos \frac{2n\pi x}{L}$$

$$11.3.10 \text{ (p. 613)} \quad C(x) = -\frac{2L^2}{3} + \frac{4L^2}{\pi^2} \sum_{n=1}^{\infty} \frac{1}{n^2} \cos \frac{n\pi x}{L}$$

$$11.3.11 \text{ (p. 614)} \quad S(x) = \frac{4}{\pi} \sum_{n=1}^{\infty} \frac{1}{(2n-1)} \sin \frac{(2n-1)\pi x}{L}$$

$$11.3.12 \text{ (p. 614)} \quad S(x) = \frac{2}{\pi} \sum_{n=1}^{\infty} \frac{1}{n} \sin n\pi x$$

$$11.3.13 \text{ (p. 614)} \quad S(x) = \frac{2}{\pi} \sum_{n=1}^{\infty} [1 - (-1)^n \cos k\pi] \frac{n}{n^2 - k^2} \sin nx$$

$$11.3.14 \text{ (p. 614)} \quad S(x) = \frac{2}{\pi} \sum_{n=1}^{\infty} \frac{1}{n} \left[ 1 - \cos \frac{n\pi}{2} \right] \sin \frac{n\pi x}{L}$$

$$11.3.15 \text{ (p. 614)} \quad S(x) = \frac{4L}{\pi^2} \sum_{n=1}^{\infty} \frac{(-1)^{n+1}}{(2n-1)^2} \sin \frac{(2n-1)\pi x}{L}$$

$$11.3.16 \text{ (p. 614)} \quad S(x) = \frac{\pi}{2} \sin x - \frac{16}{\pi} \sum_{n=1}^{\infty} \frac{n}{(4n^2 - 1)^2} \sin 2nx$$

$$11.3.17 \text{ (p. 614)} \quad S(x) = -\frac{2}{\pi} \sum_{n=1}^{\infty} \frac{n[(-1)^n e^\pi - 1]}{(n^2 + 1)} \sin nx$$

$$11.3.18 \text{ (p. 614)} \quad C_M(x) = -\frac{4}{\pi} \sum_{n=1}^{\infty} \frac{(-1)^n}{2n-1} \cos \frac{(2n-1)\pi x}{2L}$$

$$11.3.19 \text{ (p. 614)} \quad C_M(x) = -\frac{4L^2}{\pi} \sum_{n=1}^{\infty} \frac{(-1)^n}{2n-1} \left[ 1 - \frac{8}{(2n-1)^2 \pi^2} \right] \cos \frac{(2n-1)\pi x}{2L}$$

$$11.3.20 \text{ (p. 614)} \quad C_M(x) = -\frac{4}{\pi} \sum_{n=1}^{\infty} \left[ (-1)^n + \frac{2}{(2n-1)\pi} \right] \cos \frac{(2n-1)\pi x}{2}$$

$$11.3.21 \text{ (p. 614)} \quad C_M(x) = -\frac{4}{\pi} \sum_{n=1}^{\infty} \frac{1}{2n-1} \cos \frac{(2n+1)\pi}{4} \cos \frac{(2n-1)\pi x}{2L}$$

$$11.3.22 \text{ (p. 614)} \quad C_M(x) = \frac{4}{\pi} \sum_{n=1}^{\infty} (-1)^n \frac{2n-1}{(2n-3)(2n+1)} \cos \frac{(2n-1)x}{2}$$

$$11.3.23 \text{ (p. 614)} \quad C_M(x) = -\frac{8}{\pi} \sum_{n=1}^{\infty} \frac{1}{(2n-3)(2n+1)} \cos \frac{(2n-1)x}{2}$$

$$11.3.24 \text{ (p. 614)} \quad C_M(x) = -\frac{8L^2}{\pi^2} \sum_{n=1}^{\infty} \frac{1}{(2n-1)^2} \left[ 1 + \frac{4(-1)^n}{(2n-1)\pi} \right] \cos \frac{(2n-1)\pi x}{2L}$$

- 11.3.25 (p. 614)  $S_M(x) = \frac{4}{\pi} \sum_{n=1}^{\infty} \frac{1}{(2n-1)} \sin \frac{(2n-1)\pi x}{2L}$
- 11.3.26 (p. 614)  $S_M(x) = -\frac{16L^2}{\pi^2} \sum_{n=1}^{\infty} \frac{1}{(2n-1)^2} \left[ (-1)^n + \frac{2}{(2n-1)\pi} \right] \sin \frac{(2n-1)\pi x}{2L}$
- 11.3.27 (p. 614)  $S_M(x) = \frac{4}{\pi} \sum_{n=1}^{\infty} \frac{1}{2n-1} \left[ 1 - \cos \frac{(2n-1)\pi}{4} \right] \sin \frac{(2n-1)\pi x}{2L}$
- 11.3.28 (p. 614)  $S_M(x) = \frac{4}{\pi} \sum_{n=1}^{\infty} \frac{2n-1}{(2n-3)(2n+1)} \sin \frac{(2n-1)x}{2}$
- 11.3.29 (p. 614)  $S_M(x) = \frac{8}{\pi} \sum_{n=1}^{\infty} \frac{(-1)^n}{(2n-3)(2n+1)} \sin \frac{(2n-1)x}{2}$
- 11.3.30 (p. 614)  $S_M(x) = \frac{8L^2}{\pi^2} \sum_{n=1}^{\infty} \frac{1}{(2n-1)^2} \left[ (-1)^n + \frac{4}{(2n-1)\pi} \right] \sin \frac{(2n-1)\pi x}{2L}$
- 11.3.31 (p. 614)  $C(x) = -\frac{7L^4}{5} - \frac{144L^4}{\pi^4} \sum_{n=1}^{\infty} \frac{(-1)^n}{n^4} \cos \frac{n\pi x}{L}$
- 11.3.32 (p. 614)  $C(x) = -\frac{2L^4}{5} - \frac{48L^4}{\pi^4} \sum_{n=1}^{\infty} \frac{1 + (-1)^n 2}{n^4} \cos \frac{n\pi x}{L}$
- 11.3.33 (p. 614)  $C(x) = \frac{3L^4}{5} - \frac{48L^4}{\pi^4} \sum_{n=1}^{\infty} \frac{2 + (-1)^n}{n^4} \cos \frac{n\pi x}{L}$
- 11.3.34 (p. 614)  $C(x) = \frac{L^4}{30} - \frac{3L^4}{\pi^4} \sum_{n=1}^{\infty} \frac{1}{n^4} \cos \frac{2n\pi x}{L}$
- 11.3.36 (p. 615)  $S(x) = \frac{8L^2}{\pi^3} \sum_{n=1}^{\infty} \frac{1}{(2n-1)^3} \sin \frac{(2n-1)\pi x}{L}$
- 11.3.37 (p. 615)  $S(x) = -\frac{4L^3}{\pi^3} \sum_{n=1}^{\infty} \frac{(1 + (-1)^n 2)}{n^3} \sin \frac{n\pi x}{L}$
- 11.3.38 (p. 615)  $S(x) = -\frac{12L^3}{\pi^3} \sum_{n=1}^{\infty} \frac{(-1)^n}{n^3} \sin \frac{n\pi x}{L}$
- 11.3.39 (p. 615)  $S(x) = \frac{96L^4}{\pi^5} \sum_{n=1}^{\infty} \frac{1}{(2n-1)^5} \sin \frac{(2n-1)\pi x}{L}$
- 11.3.40 (p. 615)  $S(x) = -\frac{720L^5}{\pi^5} \sum_{n=1}^{\infty} \frac{(-1)^n}{n^5} \sin \frac{n\pi x}{L}$
- 11.3.41 (p. 615)  $S(x) = -\frac{240L^5}{\pi^5} \sum_{n=1}^{\infty} \frac{1 + (-1)^n 2}{n^5} \sin \frac{n\pi x}{L}$
- 11.3.43 (p. 615)  $C_M(x) = -\frac{64L^3}{\pi^3} \sum_{n=1}^{\infty} \frac{1}{(2n-1)^3} \left[ (-1)^n + \frac{3}{(2n-1)\pi} \right] \cos \frac{(2n-1)\pi x}{2L}$
- 11.3.44 (p. 615)  $C_M(x) = -\frac{32L^2}{\pi^3} \sum_{n=1}^{\infty} \frac{(-1)^n}{(2n-1)^3} \cos \frac{(2n-1)\pi x}{2L}$



$$11.3.45 \text{ (p. 615)} \quad C_M(x) = -\frac{96L^3}{\pi^3} \sum_{n=1}^{\infty} \frac{1}{(2n-1)^3} \left[ (-1)^n + \frac{2}{(2n-1)\pi} \right] \cos \frac{(2n-1)\pi x}{2L}$$

$$11.3.46 \text{ (p. 615)} \quad C_M(x) = \frac{96L^3}{\pi^3} \sum_{n=1}^{\infty} \frac{1}{(2n-1)^3} \left[ (-1)^n 3 + \frac{4}{(2n-1)\pi} \right] \cos \frac{(2n-1)\pi x}{2L}$$

$$11.3.47 \text{ (p. 615)} \quad C_M(x) = \frac{96L^3}{\pi^3} \sum_{n=1}^{\infty} \frac{1}{(2n-1)^3} \left[ (-1)^n 5 + \frac{8}{(2n-1)\pi} \right] \cos \frac{(2n-1)\pi x}{2L}$$

$$11.3.48 \text{ (p. 615)} \quad C_M(x) = -\frac{384L^4}{\pi^4} \sum_{n=1}^{\infty} \frac{1}{(2n-1)^4} \left[ 1 + \frac{(-1)^n 4}{(2n-1)\pi} \right] \cos \frac{(2n-1)\pi x}{2L}$$

$$11.3.49 \text{ (p. 615)} \quad C_M(x) = -\frac{768L^4}{\pi^4} \sum_{n=1}^{\infty} \frac{1}{(2n-1)^4} \left[ 1 + \frac{(-1)^n 2}{(2n-1)\pi} \right] \cos \frac{(2n-1)\pi x}{2L}$$

$$11.3.51 \text{ (p. 615)} \quad S_M(x) = \frac{32L^2}{\pi^3} \sum_{n=1}^{\infty} \frac{1}{(2n-1)^3} \sin \frac{(2n-1)\pi x}{2L}$$

$$11.3.52 \text{ (p. 615)} \quad S_M(x) = -\frac{96L^3}{\pi^3} \sum_{n=1}^{\infty} \frac{1}{(2n-1)^3} \left[ 1 + (-1)^n \frac{4}{(2n-1)\pi} \right] \sin \frac{(2n-1)\pi x}{2L}$$

$$11.3.53 \text{ (p. 616)} \quad S_M(x) = \frac{96L^3}{\pi^3} \sum_{n=1}^{\infty} \frac{1}{(2n-1)^3} \left[ 1 + (-1)^n \frac{2}{(2n-1)\pi} \right] \sin \frac{(2n-1)\pi x}{2L}$$

$$11.3.54 \text{ (p. 616)} \quad S_M(x) = \frac{192L^3}{\pi^4} \sum_{n=1}^{\infty} \frac{(-1)^n}{(2n-1)^4} \sin \frac{(2n-1)\pi x}{2L}$$

$$11.3.55 \text{ (p. 616)} \quad S_M(x) = \frac{1536L^4}{\pi^4} \sum_{n=1}^{\infty} \frac{1}{(2n-1)^4} \left[ (-1)^n + \frac{3}{(2n-1)\pi} \right] \sin \frac{(2n-1)\pi x}{2L}$$

$$11.3.56 \text{ (p. 616)} \quad S_M(x) = \frac{384L^4}{\pi^4} \sum_{n=1}^{\infty} \frac{1}{(2n-1)^4} \left[ (-1)^n + \frac{4}{(2n-1)\pi} \right] \sin \frac{(2n-1)\pi x}{2L}$$

**Section 12.1 Answers, pp. 626–629**

$$12.1.8 \text{ (p. 626)} \quad u(x, t) = \frac{8}{\pi^3} \sum_{n=1}^{\infty} \frac{1}{(2n-1)^3} e^{-(2n-1)^2 \pi^2 t} \sin(2n-1)\pi x$$

$$12.1.9 \text{ (p. 626)} \quad u(x, t) = \frac{4}{\pi} \sum_{n=1}^{\infty} \frac{1}{(2n-1)} e^{-9(2n-1)^2 \pi^2 t/16} \sin \frac{(2n-1)\pi x}{4}$$

$$12.1.10 \text{ (p. 626)} \quad u(x, t) = \frac{\pi}{2} e^{-3t} \sin x - \frac{16}{\pi} \sum_{n=1}^{\infty} \frac{n}{(4n^2-1)^2} e^{-12n^2 t} \sin 2nx$$

$$12.1.11 \text{ (p. 626)} \quad u(x, t) = -\frac{32}{\pi^3} \sum_{n=1}^{\infty} \frac{(1+(-1)^n 2)}{n^3} e^{-9n^2 \pi^2 t/4} \sin \frac{n\pi x}{2}$$

$$12.1.12 \text{ (p. 626)} \quad u(x, t) = -\frac{324}{\pi^3} \sum_{n=1}^{\infty} \frac{(-1)^n}{n^3} e^{-4n^2 \pi^2 t/9} \sin \frac{n\pi x}{3}$$

$$12.1.13 \text{ (p. 626)} \quad u(x, t) = \frac{8}{\pi^2} \sum_{n=1}^{\infty} \frac{(-1)^{n+1}}{(2n-1)^2} e^{-(2n-1)^2 \pi^2 t} \sin \frac{(2n-1)\pi x}{2}$$

$$12.1.14 \text{ (p. 626)} \quad u(x, t) = -\frac{720}{\pi^5} \sum_{n=1}^{\infty} \frac{(-1)^n}{n^5} e^{-7n^2 \pi^2 t} \sin n\pi x$$

$$12.1.15 \text{ (p. 626)} \quad u(x, t) = \frac{96}{\pi^5} \sum_{n=1}^{\infty} \frac{1}{(2n-1)^5} e^{-5(2n-1)^2 \pi^2 t} \sin(2n-1)\pi x$$

$$12.1.16 \text{ (p. 626)} \quad u(x, t) = -\frac{240}{\pi^5} \sum_{n=1}^{\infty} \frac{1+(-1)^n 2}{n^5} e^{-2n^2 \pi^2 t} \sin n\pi x.$$

$$12.1.17 \text{ (p. 627)} \quad u(x, t) = \frac{16}{3} + \frac{64}{\pi^2} \sum_{n=1}^{\infty} \frac{(-1)^n}{n^2} e^{-9\pi^2 n^2 t/16} \cos \frac{n\pi x}{4}$$

$$12.1.18 \text{ (p. 627)} \quad u(x, t) = -\frac{8}{3} + \frac{16}{\pi^2} \sum_{n=1}^{\infty} \frac{1}{n^2} e^{-n^2 \pi^2 t} \cos \frac{n\pi x}{2}$$

$$12.1.19 \text{ (p. 627)} \quad u(x, t) = \frac{1}{6} - \frac{1}{\pi^2} \sum_{n=1}^{\infty} \frac{1}{n^2} e^{-36n^2 \pi^2 t} \cos 2n\pi x$$

$$12.1.20 \text{ (p. 627)} \quad u(x, t) = 4 - \frac{384}{\pi^4} \sum_{n=1}^{\infty} \frac{1}{(2n-1)^4} e^{-3(2n-1)^2 \pi^2 t/4} \cos \frac{(2n-1)\pi x}{2}$$

$$12.1.21 \text{ (p. 627)} \quad u(x, y) = -\frac{28}{5} - \frac{576}{\pi^4} \sum_{n=1}^{\infty} \frac{(-1)^n}{n^4} e^{-5n^2 \pi^2 t/2} \cos \frac{n\pi x}{\sqrt{2}}$$

$$12.1.22 \text{ (p. 627)} \quad u(x, t) = -\frac{2}{5} - \frac{48}{\pi^4} \sum_{n=1}^{\infty} \frac{1+(-1)^n 2}{n^4} e^{-3n^2 \pi^2 t} \cos n\pi x$$

$$12.1.23 \text{ (p. 627)} \quad u(x, t) = \frac{3}{5} - \frac{48}{\pi^4} \sum_{n=1}^{\infty} \frac{2+(-1)^n}{n^4} e^{-n^2 \pi^2 t} \cos n\pi x$$

$$12.1.24 \text{ (p. 627)} \quad u(x, t) = \frac{\pi^4}{30} - 3 \sum_{n=1}^{\infty} \frac{1}{n^4} e^{-4n^2 t} \cos 2nx$$

$$12.1.25 \text{ (p. 627)} \quad u(x, t) = \frac{8}{\pi} \sum_{n=1}^{\infty} \frac{(-1)^n}{(2n+1)(2n-3)} e^{-(2n-1)^2 \pi^2 t/4} \sin \frac{(2n-1)\pi x}{2}$$

$$12.1.26 \text{ (p. 627)} \quad u(x, t) = 8 \sum_{n=1}^{\infty} \frac{1}{(2n-1)^2} \left[ (-1)^n + \frac{4}{(2n-1)\pi} \right] e^{-3(2n-1)^2 t/4} \sin \frac{(2n-1)x}{2}$$

$$12.1.27 \text{ (p. 627)} \quad u(x, t) = \frac{128}{\pi^3} \sum_{n=1}^{\infty} \frac{1}{(2n-1)^3} e^{-5(2n-1)^2 t/16} \sin \frac{(2n-1)\pi x}{4}$$

$$12.1.28 \text{ (p. 627)} \quad u(x, t) = -\frac{96}{\pi^3} \sum_{n=1}^{\infty} \frac{1}{(2n-1)^3} \left[ 1 + (-1)^n \frac{4}{(2n-1)\pi} \right] e^{-(2n-1)^2 \pi^2 t/4} \sin \frac{(2n-1)\pi x}{2}$$

$$12.1.29 \text{ (p. 627)} \quad u(x, t) = \frac{96}{\pi^3} \sum_{n=1}^{\infty} \frac{1}{(2n-1)^3} \left[ 1 + (-1)^n \frac{2}{(2n-1)\pi} \right] e^{-(2n-1)^2 \pi^2 t/4} \sin \frac{(2n-1)\pi x}{2}$$

$$12.1.30 \text{ (p. 627)} \quad u(x, t) = \frac{192}{\pi^4} \sum_{n=1}^{\infty} \frac{(-1)^n}{(2n-1)^4} e^{-(2n-1)^2 \pi^2 t/4} \sin \frac{(2n-1)\pi x}{2}$$

$$12.1.31 \text{ (p. 627)} \quad u(x, t) = \frac{1536}{\pi^4} \sum_{n=1}^{\infty} \frac{1}{(2n-1)^4} \left[ (-1)^n + \frac{3}{(2n-1)\pi} \right] e^{-(2n-1)^2 \pi^2 t/4} \sin \frac{(2n-1)\pi x}{2}$$

$$12.1.32 \text{ (p. 628)} \quad u(x, t) = \frac{384}{\pi^4} \sum_{n=1}^{\infty} \frac{1}{(2n-1)^4} \left[ (-1)^n + \frac{4}{(2n-1)\pi} \right] e^{-(2n-1)^2 \pi^2 t/4} \sin \frac{(2n-1)\pi x}{2}$$

- 12.1.33 (p. 628)  $u(x, t) = -64 \sum_{n=1}^{\infty} \frac{e^{-3(2n-1)^2 t/4}}{(2n-1)^3} \left[ (-1)^n + \frac{3}{(2n-1)\pi} \right] \cos \frac{(2n-1)x}{2}$
- 12.1.34 (p. 628)  $u(x, t) = -\frac{16}{\pi} \sum_{n=1}^{\infty} \frac{(-1)^n}{2n-1} e^{-(2n-1)^2 t} \cos \frac{(2n-1)x}{4}$
- 12.1.35 (p. 628)  $u(x, t) = -\frac{64}{\pi} \sum_{n=1}^{\infty} \frac{(-1)^n}{2n-1} \left[ 1 - \frac{8}{(2n-1)^2 \pi^2} \right] e^{-9(2n-1)^2 \pi^2 t/64} \cos \frac{(2n-1)\pi x}{8}$
- 12.1.36 (p. 628)  $u(x, t) = \frac{8}{\pi^2} \sum_{n=1}^{\infty} \frac{1}{(2n-1)^2} e^{-3(2n-1)^2 \pi^2 t/4} \cos \frac{(2n-1)\pi x}{2}$
- 12.1.37 (p. 628)  $u(x, t) = -\frac{96}{\pi^3} \sum_{n=1}^{\infty} \frac{1}{(2n-1)^3} \left[ (-1)^n + \frac{2}{(2n-1)\pi} \right] e^{-(2n-1)^2 \pi^2 t/4} \cos \frac{(2n-1)\pi x}{2}$
- 12.1.38 (p. 628)  $u(x, t) = -\frac{32}{\pi} \sum_{n=1}^{\infty} \frac{(-1)^n}{(2n-1)^3} e^{-7(2n-1)^2 t/4} \cos \frac{(2n-1)x}{2}$
- 12.1.39 (p. 628)  $u(x, t) = \frac{96}{\pi^3} \sum_{n=1}^{\infty} \frac{1}{(2n-1)^3} \left[ (-1)^n 5 + \frac{8}{(2n-1)\pi} \right] e^{-(2n-1)^2 \pi^2 t/4} \cos \frac{(2n-1)\pi x}{2}$
- 12.1.40 (p. 628)  $u(x, t) = \frac{96}{\pi^3} \sum_{n=1}^{\infty} \frac{1}{(2n-1)^3} \left[ (-1)^n 3 + \frac{4}{(2n-1)\pi} \right] e^{-(2n-1)^2 \pi^2 t/4} \cos \frac{(2n-1)\pi x}{2}$
- 12.1.41 (p. 628)  $u(x, t) = -\frac{768}{\pi^4} \sum_{n=1}^{\infty} \frac{1}{(2n-1)^4} \left[ 1 + \frac{(-1)^n 2}{(2n-1)\pi} \right] e^{-(2n-1)^2 \pi^2 t/4} \cos \frac{(2n-1)\pi x}{2}$
- 12.1.42 (p. 628)  $u(x, t) = -\frac{384}{\pi^4} \sum_{n=1}^{\infty} \frac{1}{(2n-1)^4} \left[ 1 + \frac{(-1)^n 4}{(2n-1)\pi} \right] e^{-(2n-1)^2 \pi^2 t/4} \cos \frac{(2n-1)\pi x}{2}$
- 12.1.43 (p. 628)  $u(x, t) = \frac{1}{2} - \frac{2}{\pi} \sum_{n=1}^{\infty} \frac{(-1)^n}{2n-1} e^{-(2n-1)^2 \pi^2 a^2 t/L^2} \cos \frac{(2n-1)\pi x}{L}$
- 12.1.44 (p. 628)  $u(x, t) = \frac{2}{\pi} \sum_{n=1}^{\infty} \frac{1}{n} \left[ 1 - \cos \frac{n\pi}{2} \right] e^{-n^2 \pi^2 a^2 t/L^2} \sin \frac{n\pi x}{L}$
- 12.1.45 (p. 629)  $u(x, t) = \frac{4}{\pi} \sum_{n=1}^{\infty} \frac{1}{2n-1} \sin \frac{(2n-1)\pi}{4} e^{-(2n-1)^2 \pi^2 a^2 t/4L^2} \cos \frac{(2n-1)\pi x}{2L}$
- 12.1.46 (p. 629)  $u(x, t) = \frac{4}{\pi} \sum_{n=1}^{\infty} \frac{1}{2n-1} \left[ 1 - \cos \frac{(2n-1)\pi}{4} \right] e^{-(2n-1)^2 \pi^2 a^2 t/4L^2} \sin \frac{(2n-1)\pi x}{2L}$
- 12.1.48 (p. 629)  $u(x, t) = 1 - x + x^3 + \frac{4}{\pi} \sum_{n=1}^{\infty} \frac{e^{-9\pi^2(2n-1)^2 t/16}}{(2n-1)} \sin \frac{(2n-1)\pi x}{4}$
- 12.1.49 (p. 629)  $u(x, t) = 1 + x + x^2 - \frac{8}{\pi^3} \sum_{n=1}^{\infty} \frac{e^{-(2n-1)^2 \pi^2 t}}{(2n-1)^3} \sin(2n-1)\pi x$
- 12.1.50 (p. 629)  $u(x, t) = -1 - x + x^3 + \frac{8}{\pi^2} \sum_{n=1}^{\infty} \frac{1}{(2n-1)^2} e^{-3(2n-1)^2 \pi^2 t/4} \cos \frac{(2n-1)\pi x}{2}$
- 12.1.51 (p. 629)  $u(x, t) = x^2 - x - 2 - \frac{64}{\pi} \sum_{n=1}^{\infty} \frac{(-1)^n}{2n-1} \left[ 1 - \frac{8}{(2n-1)^2 \pi^2} \right] e^{-9(2n-1)^2 \pi^2 t/64} \cos \frac{(2n-1)\pi x}{8}$

$$12.1.52 \text{ (p. 629)} \quad u(x, t) = \sin \pi x + \frac{8}{\pi} \sum_{n=1}^{\infty} \frac{(-1)^n}{(2n+1)(2n-3)} e^{-(2n-1)^2 \pi^2 t/4} \sin \frac{(2n-1)\pi x}{2}$$

$$12.1.53 \text{ (p. 629)} \quad u(x, t) = x^3 - x + 3 + \frac{32}{\pi^3} \sum_{n=1}^{\infty} \frac{e^{-(2n-1)^2 \pi^2 t/4}}{(2n-1)^3} \sin \frac{(2n-1)\pi x}{2}$$

**Section 12.2 Answers, pp. 642–649**

$$12.2.1 \text{ (p. 642)} \quad u(x, t) = \frac{4}{3\pi^3} \sum_{n=1}^{\infty} \frac{(-1)^{n+1}}{(2n-1)^3} \sin 3(2n-1)\pi t \sin(2n-1)\pi x$$

$$12.2.2 \text{ (p. 642)} \quad u(x, t) = \frac{8}{\pi^3} \sum_{n=1}^{\infty} \frac{1}{(2n-1)^3} \cos 3(2n-1)\pi t \sin(2n-1)\pi x$$

$$12.2.3 \text{ (p. 642)} \quad u(x, t) = -\frac{4}{\pi^3} \sum_{n=1}^{\infty} \frac{(1+(-1)^n 2)}{n^3} \cos n\sqrt{7}\pi t \sin n\pi x$$

$$12.2.4 \text{ (p. 642)} \quad u(x, t) = \frac{8}{3\pi^4} \sum_{n=1}^{\infty} \frac{1}{(2n-1)^4} \sin 3(2n-1)\pi t \sin(2n-1)\pi x$$

$$12.2.5 \text{ (p. 642)} \quad u(x, t) = -\frac{4}{\sqrt{7}\pi^4} \sum_{n=1}^{\infty} \frac{(1+(-1)^n 2)}{n^4} \sin n\sqrt{7}\pi t \sin n\pi x$$

$$12.2.6 \text{ (p. 642)} \quad u(x, t) = \frac{324}{\pi^3} \sum_{n=1}^{\infty} \frac{(-1)^n}{n^3} \cos \frac{8n\pi t}{3} \sin \frac{n\pi x}{3}$$

$$12.2.7 \text{ (p. 642)} \quad u(x, t) = \frac{96}{\pi^5} \sum_{n=1}^{\infty} \frac{1}{(2n-1)^5} \cos 2(2n-1)\pi t \sin(2n-1)\pi x$$

$$12.2.8 \text{ (p. 642)} \quad u(x, t) = \frac{243}{2\pi^4} \sum_{n=1}^{\infty} \frac{(-1)^n}{n^4} \sin \frac{8n\pi t}{3} \sin \frac{n\pi x}{3}$$

$$12.2.9 \text{ (p. 642)} \quad u(x, t) = \frac{48}{\pi^6} \sum_{n=1}^{\infty} \frac{1}{(2n-1)^6} \sin 2(2n-1)\pi t \sin(2n-1)\pi x.$$

$$12.2.10 \text{ (p. 642)} \quad u(x, t) = \frac{\pi}{2} \cos \sqrt{5} t \sin x - \frac{16}{\pi} \sum_{n=1}^{\infty} \frac{n}{(4n^2-1)^2} \cos 2n\sqrt{5} t \sin 2nx$$

$$12.2.11 \text{ (p. 642)} \quad u(x, t) = -\frac{240}{\pi^5} \sum_{n=1}^{\infty} \frac{1+(-1)^n 2}{n^5} \cos n\pi t \sin n\pi x$$

$$12.2.12 \text{ (p. 642)} \quad u(x, t) = \frac{\pi}{2\sqrt{5}} \sin \sqrt{5} t \sin x - \frac{8}{\pi\sqrt{5}} \sum_{n=1}^{\infty} \frac{1}{(4n^2-1)^2} \sin 2n\sqrt{5} t \sin 2nx$$

$$12.2.13 \text{ (p. 642)} \quad u(x, t) = -\frac{240}{\pi^6} \sum_{n=1}^{\infty} \frac{1+(-1)^n 2}{n^6} \sin n\pi t \sin n\pi x$$

$$12.2.14 \text{ (p. 643)} \quad u(x, t) = -\frac{720}{\pi^5} \sum_{n=1}^{\infty} \frac{(-1)^n}{n^5} \cos 3n\pi t \sin n\pi x$$

$$12.2.15 \text{ (p. 643)} \quad u(x, t) = -\frac{240}{\pi^6} \sum_{n=1}^{\infty} \frac{(-1)^n}{n^6} \sin 3n\pi t \sin n\pi x$$

$$12.2.18 \text{ (p. 644)} \quad u(x, t) = -\frac{128}{\pi^3} \sum_{n=1}^{\infty} \frac{(-1)^n}{(2n-1)^3} \cos \frac{3(2n-1)\pi t}{4} \cos \frac{(2n-1)\pi x}{4}$$

- 12.2.19 (p. 644)**  $u(x, t) = -\frac{64}{\pi^3} \sum_{n=1}^{\infty} \frac{1}{(2n-1)^3} \left[ (-1)^n + \frac{3}{(2n-1)\pi} \right] \cos(2n-1)\pi t \cos \frac{(2n-1)\pi x}{2}$
- 12.2.20 (p. 644)**  $u(x, t) = -\frac{512}{3\pi^4} \sum_{n=1}^{\infty} \frac{(-1)^n}{(2n-1)^4} \sin \frac{3(2n-1)\pi t}{4} \cos \frac{(2n-1)\pi x}{4}$
- 12.2.21 (p. 644)**  $u(x, t) = -\frac{64}{\pi^4} \sum_{n=1}^{\infty} \frac{1}{(2n-1)^4} \left[ (-1)^n + \frac{3}{(2n-1)\pi} \right] \sin(2n-1)\pi t \cos \frac{(2n-1)\pi x}{2}$
- 12.2.22 (p. 644)**  $u(x, t) = \frac{96}{\pi^3} \sum_{n=1}^{\infty} \frac{1}{(2n-1)^3} \left[ (-1)^{n3} + \frac{4}{(2n-1)\pi} \right] \cos \frac{(2n-1)\sqrt{5}\pi t}{2} \cos \frac{(2n-1)\pi x}{2}$
- 12.2.23 (p. 644)**  $u(x, t) = -96 \sum_{n=1}^{\infty} \frac{1}{(2n-1)^3} \left[ (-1)^n + \frac{2}{(2n-1)\pi} \right] \cos \frac{(2n-1)\sqrt{3}t}{2} \cos \frac{(2n-1)x}{2}$
- 12.2.24 (p. 644)**  $u(x, t) = \frac{192}{\pi^4\sqrt{5}} \sum_{n=1}^{\infty} \frac{1}{(2n-1)^4} \left[ (-1)^{n3} + \frac{4}{(2n-1)\pi} \right] \sin \frac{(2n-1)\sqrt{5}\pi t}{2} \cos \frac{(2n-1)\pi x}{2}$
- 12.2.25 (p. 644)**  $u(x, t) = -\frac{192}{\sqrt{3}} \sum_{n=1}^{\infty} \frac{1}{(2n-1)^4} \left[ (-1)^n + \frac{2}{(2n-1)\pi} \right] \sin \frac{(2n-1)\sqrt{3}t}{2} \sin \frac{(2n-1)x}{2}$
- 12.2.26 (p. 644)**  $u(x, t) = -\frac{384}{\pi^4} \sum_{n=1}^{\infty} \frac{1}{(2n-1)^4} \left[ 1 + \frac{(-1)^{n4}}{(2n-1)\pi} \right] \cos \frac{3(2n-1)\pi t}{2} \cos \frac{(2n-1)\pi x}{2}$
- 12.2.27 (p. 644)**  $u(x, t) = \frac{96}{\pi^3} \sum_{n=1}^{\infty} \frac{1}{(2n-1)^3} \left[ (-1)^{n5} + \frac{8}{(2n-1)\pi} \right] \cos \frac{(2n-1)\sqrt{7}\pi t}{2} \cos \frac{(2n-1)\pi x}{2}$
- 12.2.28 (p. 644)**  $u(x, t) = -\frac{768}{3\pi^5} \sum_{n=1}^{\infty} \frac{1}{(2n-1)^5} \left[ 1 + \frac{(-1)^{n4}}{(2n-1)\pi} \right] \sin \frac{3(2n-1)\pi t}{2} \cos \frac{(2n-1)\pi x}{2}$
- 12.2.29 (p. 644)**  $u(x, t) = \frac{192}{\pi^4\sqrt{7}} \sum_{n=1}^{\infty} \frac{1}{(2n-1)^4} \left[ (-1)^{n5} + \frac{8}{(2n-1)\pi} \right] \sin \frac{(2n-1)\sqrt{7}\pi t}{2} \cos \frac{(2n-1)\pi x}{2}$
- 12.2.30 (p. 645)**  $u(x, t) = -\frac{768}{\pi^4} \sum_{n=1}^{\infty} \frac{1}{(2n-1)^4} \left[ 1 + \frac{(-1)^{n2}}{(2n-1)\pi} \right] \cos \frac{(2n-1)\pi t}{2} \cos \frac{(2n-1)\pi x}{2}$
- 12.2.31 (p. 645)**  $u(x, t) = -\frac{1536}{\pi^5} \sum_{n=1}^{\infty} \frac{1}{(2n-1)^5} \left[ 1 + \frac{(-1)^{n2}}{(2n-1)\pi} \right] \sin \frac{(2n-1)\pi t}{2} \cos \frac{(2n-1)\pi x}{2}$
- 12.2.32 (p. 645)**  $u(x, t) = \frac{1}{2} [C_{Mf}(x+at) + C_{Mf}(x-at)] + \frac{1}{2a} \int_{x-at}^{x+at} C_{Mg}(\tau) d\tau$
- 12.2.35 (p. 645)**  $u(x, t) = \frac{32}{\pi} \sum_{n=1}^{\infty} \frac{1}{(2n-1)^3} \cos 4(2n-1)t \sin \frac{(2n-1)x}{2}$
- 12.2.36 (p. 645)**  $u(x, t) = -\frac{96}{\pi^3} \sum_{n=1}^{\infty} \frac{1}{(2n-1)^3} \left[ 1 + (-1)^n \frac{4}{(2n-1)\pi} \right] \cos \frac{3(2n-1)\pi t}{2} \sin \frac{(2n-1)\pi x}{2}$
- 12.2.37 (p. 645)**  $u(x, t) = \frac{8}{\pi} \sum_{n=1}^{\infty} \frac{1}{(2n-1)^4} \sin 4(2n-1)t \sin \frac{(2n-1)x}{2}$
- 12.2.38 (p. 646)**  $u(x, t) = -\frac{64}{\pi^4} \sum_{n=1}^{\infty} \frac{1}{(2n-1)^4} \left[ 1 + (-1)^n \frac{4}{(2n-1)\pi} \right] \sin \frac{3(2n-1)\pi t}{2} \sin \frac{(2n-1)\pi x}{2}$

$$12.2.39 \text{ (p. 646)} \quad u(x, t) = \frac{96}{\pi^3} \sum_{n=1}^{\infty} \frac{1}{(2n-1)^3} \left[ 1 + (-1)^n \frac{2}{(2n-1)\pi} \right] \cos \frac{3(2n-1)\pi t}{2} \sin \frac{(2n-1)\pi x}{2}$$

$$12.2.40 \text{ (p. 646)} \quad u(x, t) = \frac{192}{\pi} \sum_{n=1}^{\infty} \frac{(-1)^n}{(2n-1)^4} \cos \frac{(2n-1)\sqrt{3}t}{2} \sin \frac{(2n-1)x}{2}$$

$$12.2.41 \text{ (p. 646)} \quad u(x, t) = \frac{64}{\pi^4} \sum_{n=1}^{\infty} \frac{1}{(2n-1)^4} \left[ 1 + (-1)^n \frac{2}{(2n-1)\pi} \right] \sin \frac{3(2n-1)\pi t}{2} \sin \frac{(2n-1)\pi x}{2}$$

$$12.2.42 \text{ (p. 646)} \quad u(x, t) = \frac{384}{\sqrt{3}\pi} \sum_{n=1}^{\infty} \frac{(-1)^n}{(2n-1)^5} \sin \frac{(2n-1)\sqrt{3}t}{2} \sin \frac{(2n-1)x}{2}$$

$$12.2.43 \text{ (p. 646)} \quad u(x, t) = \frac{1536}{\pi^4} \sum_{n=1}^{\infty} \frac{1}{(2n-1)^4} \left[ (-1)^n + \frac{3}{(2n-1)\pi} \right] \cos \frac{(2n-1)\sqrt{5}\pi t}{2} \sin \frac{(2n-1)\pi x}{2}$$

$$12.2.44 \text{ (p. 646)} \quad u(x, t) = \frac{384}{\pi^4} \sum_{n=1}^{\infty} \frac{1}{(2n-1)^4} \left[ (-1)^n + \frac{4}{(2n-1)\pi} \right] \cos(2n-1)\pi t \sin \frac{(2n-1)\pi x}{2}$$

$$12.2.45 \text{ (p. 646)} \quad u(x, t) = \frac{3072}{\sqrt{5}\pi^5} \sum_{n=1}^{\infty} \frac{1}{(2n-1)^5} \left[ (-1)^n + \frac{3}{(2n-1)\pi} \right] \sin \frac{(2n-1)\sqrt{5}\pi t}{2} \sin \frac{(2n-1)\pi x}{2}$$

$$12.2.46 \text{ (p. 646)} \quad u(x, t) = \frac{384}{\pi^5} \sum_{n=1}^{\infty} \frac{1}{(2n-1)^5} \left[ (-1)^n + \frac{4}{(2n-1)\pi} \right] \sin(2n-1)\pi t \sin \frac{(2n-1)\pi x}{2}$$

$$12.2.47 \text{ (p. 646)} \quad u(x, t) = \frac{1}{2} [S_{Mf}(x+at) + S_{Mf}(x-at)] + \frac{1}{2a} \int_{x-at}^{x+at} S_{Mg}(\tau) d\tau$$

$$12.2.50 \text{ (p. 647)} \quad u(x, t) = 4 - \frac{768}{\pi^4} \sum_{n=1}^{\infty} \frac{1}{(2n-1)^4} \cos \frac{\sqrt{5}(2n-1)\pi t}{2} \cos \frac{(2n-1)\pi x}{2}$$

$$12.2.51 \text{ (p. 647)} \quad u(x, t) = 4t - \frac{1536}{\sqrt{5}\pi^5} \sum_{n=1}^{\infty} \frac{1}{(2n-1)^5} \sin \frac{\sqrt{5}(2n-1)\pi t}{2} \cos \frac{(2n-1)\pi x}{2}$$

$$12.2.52 \text{ (p. 647)} \quad u(x, t) = -\frac{2\pi^4}{5} - 48 \sum_{n=1}^{\infty} \frac{1 + (-1)^{n2}}{n^4} \cos 2nt \cos nx$$

$$12.2.53 \text{ (p. 647)} \quad u(x, t) = -\frac{7}{5} - \frac{144}{\pi^4} \sum_{n=1}^{\infty} \frac{(-1)^n}{n^4} \cos n\sqrt{7}\pi t \cos n\pi x$$

$$12.2.54 \text{ (p. 647)} \quad u(x, t) = -\frac{2\pi^4 t}{5} - 24 \sum_{n=1}^{\infty} \frac{1 + (-1)^{n2}}{n^5} \sin 2nt \cos nx$$

$$12.2.55 \text{ (p. 647)} \quad u(x, t) = -\frac{7t}{5} - \frac{144}{\pi^5 \sqrt{7}} \sum_{n=1}^{\infty} \frac{(-1)^n}{n^5} \sin n\sqrt{7}\pi t \cos n\pi x$$

$$12.2.56 \text{ (p. 647)} \quad u(x, t) = \frac{\pi^4}{30} - 3 \sum_{n=1}^{\infty} \frac{1}{n^4} \cos 8nt \cos 2nx$$

$$12.2.57 \text{ (p. 647)} \quad u(x, t) = \frac{3}{5} - \frac{48}{\pi^4} \sum_{n=1}^{\infty} \frac{2 + (-1)^n}{n^4} \cos n\pi t \cos n\pi x$$

$$12.2.58 \text{ (p. 647)} \quad u(x, t) = \frac{\pi^4 t}{30} - \frac{3}{8} \sum_{n=1}^{\infty} \frac{1}{n^5} \sin 8nt \cos 2nx$$

$$12.2.59 \text{ (p. 647)} \quad u(x, t) = \frac{3t}{5} - \frac{48}{\pi^5} \sum_{n=1}^{\infty} \frac{2 + (-1)^n}{n^5} \sin n\pi t \cos n\pi x$$

$$12.2.60 \text{ (p. 647)} \quad u(x, t) = \frac{1}{2}[C_f(x + at) + C_f(x - at)] + \frac{1}{2a} \int_{x-at}^{x+at} C_g(\tau) d\tau$$

$$12.2.63 \text{ (p. 648) (c)} \quad u(x, t) = \frac{f(x + at) + f(x - at)}{2} + \frac{1}{2a} \int_{x-at}^{x+at} g(u) du$$

$$12.2.64 \text{ (p. 649)} \quad u(x, t) = x(1 + 4at) \quad 12.2.65 \text{ (p. 649)} \quad u(x, t) = x^2 + a^2 t^2 + t$$

$$12.2.66 \text{ (p. 649)} \quad u(x, t) = \sin(x + at) \quad 12.2.67 \text{ (p. 649)} \quad u(x, t) = x^3 + 6tx^2 + 3a^2 t^2 x + 2a^2 t^3$$

$$12.2.68 \text{ (p. 649)} \quad u(x, t) = x \sin x \cos at + at \cos x \sin at + \frac{\sin x \sin at}{a}$$

**Section 12.3 Answers, pp. 662–665**

$$12.3.1 \text{ (p. 662)} \quad u(x, y) = \frac{8}{\pi^3} \sum_{n=1}^{\infty} \frac{\sinh(2n-1)\pi(1-y)}{(2n-1)^3 \sinh(2n-1)\pi} \sin(2n-1)\pi x$$

$$12.3.2 \text{ (p. 662)} \quad u(x, y) = -\frac{32}{\pi^3} \sum_{n=1}^{\infty} \frac{(1 + (-1)^n 2) \sinh n\pi(3-y)/2}{n^3 \sinh 3n\pi/2} \sin \frac{n\pi x}{2}$$

$$12.3.3 \text{ (p. 662)} \quad u(x, y) = \frac{8}{\pi^2} \sum_{n=1}^{\infty} (-1)^{n+1} \frac{\sinh(2n-1)\pi(1-y/2)}{(2n-1)^2 \sinh(2n-1)\pi} \sin \frac{(2n-1)\pi x}{2}$$

$$12.3.4 \text{ (p. 662)} \quad u(x, y) = \frac{\pi \sinh(1-y)}{2 \sinh 1} \sin x - \frac{16}{\pi} \sum_{n=1}^{\infty} \frac{n \sinh 2n(1-y)}{(4n^2-1)^2 \sinh 2n} \sin 2nx$$

$$12.3.5 \text{ (p. 662)} \quad u(x, y) = 3y + \frac{108}{\pi^3} \sum_{n=1}^{\infty} (-1)^n \frac{\sinh n\pi y/3}{n^3 \cosh 2n\pi/3} \cos \frac{n\pi x}{3}$$

$$12.3.6 \text{ (p. 662)} \quad u(x, y) = \frac{y}{2} + \frac{4}{\pi^3} \sum_{n=1}^{\infty} \frac{\sinh(2n-1)\pi y}{(2n-1)^3 \cosh 2(2n-1)\pi} \cos(2n-1)\pi x$$

$$12.3.7 \text{ (p. 662)} \quad u(x, y) = -\frac{8y}{3} + \frac{32}{\pi^3} \sum_{n=1}^{\infty} (-1)^n \frac{\sinh n\pi y/2}{n^3 \cosh n\pi} \cos \frac{n\pi x}{2}$$

$$12.3.8 \text{ (p. 662)} \quad u(x, y) = \frac{y}{3} + \frac{4}{\pi^3} \sum_{n=1}^{\infty} \frac{\sinh n\pi y}{n^3 \cosh n\pi} \cos n\pi x$$

$$12.3.9 \text{ (p. 662)} \quad u(x, y) = \frac{128}{\pi^3} \sum_{n=1}^{\infty} \frac{\cosh(2n-1)\pi(x-3)/4}{(2n-1)^3 \cosh 3(2n-1)\pi/4} \sin \frac{(2n-1)\pi y}{4}$$

$$12.3.10 \text{ (p. 662)} \quad u(x, y) = -\frac{96}{\pi^3} \sum_{n=1}^{\infty} \left[ 1 + (-1)^n \frac{4}{(2n-1)\pi} \right] \frac{\cosh(2n-1)\pi(x-2)/2}{(2n-1)^3 \cosh(2n-1)\pi} \sin \frac{(2n-1)\pi y}{2}$$

$$12.3.11 \text{ (p. 662)} \quad u(x, y) = \frac{768}{\pi^3} \sum_{n=1}^{\infty} \left[ 1 + (-1)^n \frac{2}{(2n-1)\pi} \right] \frac{\cosh(2n-1)\pi(x-2)/4}{(2n-1)^3 \cosh(2n-1)\pi/2} \sin \frac{(2n-1)\pi y}{4}$$

$$12.3.12 \text{ (p. 662)} \quad u(x, y) = \frac{96}{\pi^3} \sum_{n=1}^{\infty} \left[ 3 + (-1)^n \frac{4}{(2n-1)\pi} \right] \frac{\cosh(2n-1)\pi(x-3)/2}{(2n-1)^3 \cosh 3(2n-1)\pi/2} \sin \frac{(2n-1)\pi y}{2}$$

$$12.3.13 \text{ (p. 663)} \quad u(x, y) = -\frac{16}{\pi} \sum_{n=1}^{\infty} \frac{\cosh(2n-1)x/2}{(2n-3)(2n+1)(2n-1) \sinh(2n-1)/2} \cos \frac{(2n-1)y}{2}$$

$$12.3.14 \text{ (p. 663)} \quad u(x, y) = -\frac{432}{\pi^3} \sum_{n=1}^{\infty} \left[ 1 + \frac{4(-1)^n}{(2n-1)\pi} \right] \frac{\cosh(2n-1)\pi x/6}{(2n-1)^3 \sinh(2n-1)\pi/3} \cos \frac{(2n-1)\pi y}{6}$$

$$12.3.15 \text{ (p. 663)} \quad u(x, y) = -\frac{64}{\pi} \sum_{n=1}^{\infty} (-1)^n \frac{\cosh(2n-1)x/2}{(2n-1)^4 \sinh(2n-1)/2} \cos \frac{(2n-1)y}{2}.$$

$$12.3.16 \text{ (p. 663)} \quad u(x, y) = -\frac{192}{\pi^4} \sum_{n=1}^{\infty} \frac{\cosh(2n-1)\pi x/2}{(2n-1)^4 \sinh(2n-1)\pi/2} \left[ (-1)^n + \frac{2}{(2n-1)\pi} \right] \cos \frac{(2n-1)\pi y}{2}$$

$$12.3.17 \text{ (p. 663)} \quad u(x, y) = \sum_{n=1}^{\infty} \alpha_n \frac{\sinh n\pi y/a}{\sinh n\pi b/a} \sin \frac{n\pi x}{a}, \quad \alpha_n = \frac{2}{a} \int_0^a f(x) \sin \frac{n\pi x}{a} dx$$

$$u(x, y) = \frac{72}{\pi^3} \sum_{n=1}^{\infty} \frac{\sinh(2n-1)\pi y/3}{(2n-1)^3 \sinh 2(2n-1)\pi/3} \sin \frac{(2n-1)\pi x}{3}$$

$$12.3.18 \text{ (p. 663)} \quad u(x, y) = \alpha_0(1-y/b) + \sum_{n=1}^{\infty} \alpha_n \frac{\sinh n\pi(b-y)/a}{\sinh n\pi b/a} \cos \frac{n\pi x}{a}, \quad \alpha_0 = \frac{1}{a} \int_0^a f(x) dx,$$

$$\alpha_n = \frac{2}{a} \int_0^a f(x) \cos \frac{n\pi x}{a} dx, \quad n \geq 1$$

$$u(x, y) = \frac{8(1-y)}{15} - \frac{48}{\pi^4} \sum_{n=1}^{\infty} \frac{1}{n^4} \frac{\sinh n\pi(1-y)}{\sinh n\pi} \cos n\pi x$$

$$12.3.19 \text{ (p. 663)} \quad u(x, y) = \sum_{n=1}^{\infty} \alpha_n \frac{\sinh(2n-1)\pi(b-y)/2a}{\sinh(2n-1)\pi b/2a} \cos \frac{(2n-1)\pi x}{2a},$$

$$\alpha_n = \frac{2}{a} \int_0^a f(x) \cos \frac{(2n-1)\pi x}{2a} dx$$

$$u(x, y) = \frac{288}{\pi^3} \sum_{n=1}^{\infty} \frac{\sinh(2n-1)\pi(2-y)/6}{(2n-1)^3 \sinh(2n-1)\pi/3} \sin \frac{(2n-1)\pi x}{6}$$

$$12.3.20 \text{ (p. 663)} \quad u(x, y) = \sum_{n=1}^{\infty} \alpha_n \frac{\sinh(2n-1)\pi(b-y)/2a}{\sinh(2n-1)\pi b/2a} \sin \frac{(2n-1)\pi x}{2a},$$

$$\alpha_n = \frac{2}{a} \int_0^a f(x) \sin \frac{(2n-1)\pi x}{2a} dx$$

$$u(x, y) = \frac{32}{\pi^3} \sum_{n=1}^{\infty} \left[ (-1)^n 5 + \frac{18}{(2n-1)\pi} \right] \frac{\sinh(2n-1)\pi(2-y)/2}{(2n-1)^3 \sinh(2n-1)\pi} \cos \frac{(2n-1)\pi x}{2}.$$

$$12.3.21 \text{ (p. 663)} \quad u(x, y) = \sum_{n=1}^{\infty} \alpha_n \frac{\cosh n\pi(y-b)/a}{\cosh n\pi b/a} \sin \frac{n\pi x}{a}, \quad \alpha_n = \frac{2}{a} \int_0^a f(x) \sin \frac{n\pi x}{a} dx$$

$$u(x, y) = -12 \sum_{n=1}^{\infty} (-1)^n \frac{\cosh n(y-2)}{n^3 \cosh 2n} \sin nx$$

$$12.3.22 \text{ (p. 663)} \quad u(x, y) = \alpha_0 + \sum_{n=1}^{\infty} \alpha_n \frac{\cosh n\pi y/a}{\cosh n\pi b/a} \cos \frac{n\pi x}{a}, \quad \alpha_0 = \frac{1}{a} \int_0^a f(x) dx,$$

$$\alpha_n = \frac{2}{a} \int_0^a f(x) \cos \frac{n\pi x}{a} dx, \quad n \geq 1$$

$$u(x, y) = \frac{\pi^4}{30} - 3 \sum_{n=1}^{\infty} \frac{1}{n^4} \frac{\cosh 2ny}{\cosh 2n} \cos 2nx$$

$$12.3.23 \text{ (p. 663)} \quad u(x, y) = \frac{a}{\pi} \sum_{n=1}^{\infty} \alpha_n \frac{\sinh n\pi(y-b)/a}{n \cosh n\pi b/a} \sin \frac{n\pi x}{a}, \quad \alpha_n = \frac{2}{a} \int_0^a f(x) \sin \frac{n\pi x}{a} dx$$

$$u(x, y) = \frac{4}{\pi} \sum_{n=1}^{\infty} (-1)^{n+1} \frac{\sinh(2n-1)(y-1)}{(2n-1)^3 \cosh(2n-1)} \sin(2n-1)x$$



$$12.3.24 \text{ (p. 663)} \quad u(x, y) = \sum_{n=1}^{\infty} \alpha_n \frac{\cosh n\pi x/b}{\cosh n\pi a/b} \sin \frac{n\pi y}{b}, \quad \alpha_n = \frac{2}{b} \int_0^b g(y) \sin \frac{n\pi y}{b} dy$$

$$u(x, y) = \frac{96}{\pi^5} \sum_{n=1}^{\infty} \frac{\cosh(2n-1)\pi x}{(2n-1)^5 \cosh(2n-1)\pi} \sin(2n-1)\pi y.$$

$$12.3.25 \text{ (p. 664)} \quad u(x, y) = \sum_{n=1}^{\infty} \alpha_n \frac{\cosh(2n-1)\pi x/2b}{\cosh(2n-1)\pi a/2b} \cos \frac{(2n-1)\pi y}{2b},$$

$$\alpha_n = \frac{2}{b} \int_0^b g(y) \cos \frac{(2n-1)\pi y}{2b} dy$$

$$u(x, y) = -\frac{128}{\pi^3} \sum_{n=1}^{\infty} (-1)^n \frac{\cosh(2n-1)\pi x/4}{(2n-1)^3 \cosh(2n-1)\pi/2} \cos \frac{(2n-1)\pi y}{4}.$$

$$12.3.26 \text{ (p. 664)} \quad u(x, y) = \frac{b}{\pi} \sum_{n=1}^{\infty} \alpha_n \frac{\cosh n\pi x/b}{n \sinh n\pi a/b} \sin \frac{n\pi y}{b}, \quad \alpha_n = \frac{2}{b} \int_0^b g(y) \sin \frac{n\pi y}{b} dy$$

$$u(x, y) = \frac{64}{\pi^3} \sum_{n=1}^{\infty} (-1)^{n+1} \frac{\cosh(2n-1)\pi x/4}{(2n-1)^3 \sinh(2n-1)\pi/4} \sin \frac{(2n-1)\pi y}{4}$$

$$12.3.27 \text{ (p. 664)} \quad u(x, y) = -\frac{2b}{\pi} \sum_{n=1}^{\infty} \alpha_n \frac{\cosh(2n-1)\pi(x-a)/2b}{(2n-1) \sinh(2n-1)\pi a/2b} \sin \frac{(2n-1)y}{2b},$$

$$\alpha_n = \frac{2}{b} \int_0^b g(y) \sin \frac{(2n-1)\pi y}{2b} dy$$

$$u(x, y) = 192 \sum_{n=1}^{\infty} \left[ 1 + (-1)^n \frac{4}{(2n-1)\pi} \right] \frac{\cosh(2n-1)(x-1)/2}{(2n-1)^4 \sinh(2n-1)/2} \sin \frac{(2n-1)y}{2}.$$

$$12.3.28 \text{ (p. 664)} \quad u(x, y) = \alpha_0(x-a) + \frac{b}{\pi} \sum_{n=1}^{\infty} \alpha_n \frac{\sinh n\pi(x-a)/b}{n \cosh n\pi a/b} \cos \frac{n\pi y}{b}, \quad \alpha_0 = \frac{1}{b} \int_0^b g(y) \cos \frac{n\pi y}{b} dy,$$

$$\alpha_n = \frac{2}{b} \int_0^b g(y) \cos \frac{n\pi y}{b} dy$$

$$u(x, y) = \frac{\pi(x-2)}{2} - \frac{4}{\pi} \sum_{n=1}^{\infty} \frac{\sinh(2n-1)(x-2)}{(2n-1)^3 \cosh 2(2n-1)} \cos(2n-1)y.$$

$$12.3.29 \text{ (p. 664)} \quad u(x, y) = \alpha_0 + \sum_{n=1}^{\infty} \alpha_n e^{-n\pi y/a} \cos \frac{n\pi x}{a}, \quad \alpha_0 = \frac{1}{a} \int_0^a f(x) dx,$$

$$\alpha_n = \frac{2}{a} \int_0^a f(x) \cos \frac{n\pi x}{a} dx, \quad n \geq 1$$

$$u(x, y) = \frac{\pi^3}{2} - \frac{48}{\pi} \sum_{n=1}^{\infty} \frac{1}{(2n-1)^4} e^{-(2n-1)y} \cos(2n-1)x$$

$$12.3.30 \text{ (p. 664)} \quad u(x, y) = \sum_{n=1}^{\infty} \alpha_n e^{-(2n-1)\pi y/2a} \cos \frac{(2n-1)\pi x}{2a}, \quad \alpha_n = \frac{2}{a} \int_0^a f(x) \cos \frac{(2n-1)\pi x}{2a} dx$$

$$u(x, y) = -\frac{288}{\pi^3} \sum_{n=1}^{\infty} \frac{(-1)^n}{(2n-1)^3} e^{-(2n-1)\pi y/6} \cos \frac{(2n-1)\pi x}{6}$$

$$12.3.31 \text{ (p. 664)} \quad u(x, y) = \sum_{n=1}^{\infty} \alpha_n e^{-(2n-1)\pi y/2a} \sin \frac{(2n-1)\pi x}{2a}, \quad \alpha_n = \frac{2}{a} \int_0^a f(x) \sin \frac{(2n-1)\pi x}{2a} dx$$

$$u(x, y) = \frac{32}{\pi} \sum_{n=1}^{\infty} \frac{1}{(2n-1)^3} e^{-(2n-1)y/2} \sin \frac{(2n-1)x}{2}.$$

$$12.3.32 \text{ (p. 664)} \quad u(x, y) = -\frac{a}{\pi} \sum_{n=1}^{\infty} \frac{\alpha_n}{n} e^{-n\pi y/a} \sin \frac{n\pi x}{a}, \quad \alpha_n = \frac{2}{a} \int_0^a f(x) \sin \frac{n\pi x}{a} dx$$

$$u(x, y) = 4 \sum_{n=1}^{\infty} \frac{(1 + (-1)^n 2)}{n^4} e^{-ny} \sin nx$$

$$12.3.33 \text{ (p. 664)} \quad u(x, y) = -\frac{2a}{\pi} \sum_{n=1}^{\infty} \frac{\alpha_n}{2n-1} e^{-(2n-1)\pi y/2a} \cos \frac{(2n-1)\pi x}{2a}, \quad \alpha_n = \frac{2}{a} \int_0^a f(x) \cos \frac{(2n-1)\pi x}{2a} dx$$

$$u(x, y) = \frac{5488}{\pi^3} \sum_{n=1}^{\infty} \frac{1}{(2n-1)^3} \left[ 1 + \frac{4(-1)^n}{(2n-1)\pi} \right] e^{-(2n-1)\pi y/14} \cos \frac{(2n-1)\pi x}{14}$$

$$12.3.34 \text{ (p. 664)} \quad u(x, y) = -\frac{2a}{\pi} \sum_{n=1}^{\infty} \frac{\alpha_n}{2n-1} e^{-(2n-1)\pi y/2a} \sin \frac{(2n-1)\pi x}{2a}, \quad \alpha_n = \frac{2}{a} \int_0^a f(x) \sin \frac{(2n-1)\pi x}{2a} dx$$

$$u(x, y) = -\frac{2000}{\pi^3} \sum_{n=1}^{\infty} \frac{1}{(2n-1)^3} \left[ (-1)^n + \frac{4}{(2n-1)\pi} \right] e^{-(2n-1)\pi y/10} \sin \frac{(2n-1)\pi x}{10}$$

$$12.3.35 \text{ (p. 664)} \quad u(x, y) = \sum_{n=1}^{\infty} \frac{A_n \sinh n\pi(b-y)/a + B_n \sinh n\pi y/a}{\sinh n\pi b/a} \sin \frac{n\pi x}{a} \\ + \sum_{n=1}^{\infty} \frac{C_n \sinh n\pi(a-x)/b + D_n \sinh n\pi x/b}{\sinh n\pi a/b} \sin \frac{n\pi y}{b}$$

$$12.3.36 \text{ (p. 664)} \quad u(x, y) = C + \frac{a}{\pi} \sum_{n=1}^{\infty} \frac{B_n \cosh n\pi y/a - A_n \cosh n\pi(y-b)/a}{n \sinh n\pi b/a} \cos \frac{n\pi x}{a} \\ + \frac{b}{\pi} \sum_{n=1}^{\infty} \frac{D_n \cosh n\pi x/b - C_n \cosh n\pi(x-a)/b}{n \sinh n\pi a/b} \cos \frac{n\pi y}{b}$$

## Section 12.4 Answers, pp. 672–673

$$12.4.1 \text{ (p. 672)} \quad u(r, \theta) = \alpha_0 \frac{\ln r/\rho}{\ln \rho_0/\rho} + \sum_{n=1}^{\infty} \frac{r^n \rho^{-n} - \rho^n r^{-n}}{\rho_0^n \rho^{-n} - \rho^n \rho_0^{-n}} (\alpha_n \cos n\theta + \beta_n \sin n\theta) \quad \alpha_0 = \frac{1}{2\pi} \int_{-\pi}^{\pi} f(\theta) d\theta,$$

$$\text{and } \alpha_n = \frac{1}{\pi} \int_{-\pi}^{\pi} f(\theta) \cos n\theta d\theta, \quad \beta_n = \frac{1}{\pi} \int_{-\pi}^{\pi} f(\theta) \sin n\theta d\theta, \quad n = 1, 2, 3, \dots$$

$$12.4.2 \text{ (p. 672)} \quad u(r, \theta) = \sum_{n=1}^{\infty} \alpha_n \frac{\rho_0^{-n\pi/\gamma} r^{n\pi/\gamma} - \rho_0^{n\pi/\gamma} r^{-n\pi/\gamma}}{\rho_0^{-n\pi/\gamma} \rho^{n\pi/\gamma} - \rho_0^{n\pi/\gamma} \rho^{-n\pi/\gamma}} \sin \frac{n\pi\theta}{\gamma}$$

$$\alpha_n = \frac{1}{\gamma} \int_0^{\gamma} f(\theta) \sin \frac{n\pi\theta}{\gamma} d\theta, \quad n = 1, 2, 3, \dots$$

$$12.4.3 \text{ (p. 672)} \quad u(r, \theta) = \rho\alpha_0 \ln \frac{r}{\rho_0} + \frac{\rho\gamma}{\pi} \sum_{n=1}^{\infty} \frac{\alpha_n \rho_0^{-n\pi/\gamma} r^{n\pi/\gamma} - \rho_0^{n\pi/\gamma} r^{-n\pi/\gamma}}{n \rho_0^{-n\pi/\gamma} \rho^{n\pi/\gamma} + \rho_0^{n\pi/\gamma} \rho^{-n\pi/\gamma}} \cos \frac{n\pi\theta}{\gamma}$$

$$\alpha_0 = \frac{1}{\gamma} \int_0^{\gamma} f(\theta) d\theta, \quad \alpha_n = \frac{2}{\gamma} \int_0^{\gamma} f(\theta) \cos \frac{n\pi\theta}{\gamma} d\theta, \quad n = 1, 2, 3, \dots$$

$$12.4.4 \text{ (p. 672)} \quad u(r, \theta) = \sum_{n=1}^{\infty} \alpha_n \frac{r^{(2n-1)\pi/2\gamma}}{\rho^{(2n-1)\pi/2\gamma}} \cos \frac{(2n-1)\pi\theta}{2\gamma}$$

$$\alpha_n = \frac{2}{\gamma} \int_0^{\gamma} f(\theta) \cos \frac{(2n-1)\pi\theta}{2\gamma} d\theta, \quad n = 1, 2, 3, \dots$$

$$12.4.5 \text{ (p. 673)} \quad u(r, \theta) = \frac{2\gamma\rho_0}{\pi} \sum_{n=1}^{\infty} \frac{\alpha_n \rho^{-(2n-1)\pi/2\gamma} r^{(2n-1)\pi/2\gamma} + \rho^{(2n-1)\pi/2\gamma} r^{-(2n-1)\pi/2\gamma}}{2n-1 \rho^{-(2n-1)\pi/2\gamma} \rho_0^{(2n-1)\pi/2\gamma} - \rho^{(2n-1)\pi/2\gamma} \rho_0^{-(2n-1)\pi/2\gamma}} \sin \frac{(2n-1)\pi\theta}{2\gamma},$$

$$\alpha_n = \frac{2}{\gamma} \int_0^\gamma g(\theta) \sin \frac{(2n-1)\pi\theta}{2\gamma} d\theta, \quad n = 1, 2, 3, \dots$$

$$12.4.6 \text{ (p. 673)} \quad u(r, \theta) = \alpha_0 + \sum_{n=1}^{\infty} \alpha_n \frac{r^{n\pi/\gamma}}{\rho^{n\pi/\gamma}} \cos \frac{n\pi\theta}{\gamma} \quad \alpha_0 = \frac{1}{\gamma} \int_0^\gamma f(\theta) d\theta,$$

$$\alpha_n = \frac{2}{\gamma} \int_0^\gamma f(\theta) \cos \frac{n\pi\theta}{\gamma} d\theta, \quad n = 1, 2, 3, \dots$$

$$12.4.7 \text{ (p. 673)} \quad v_n(r, \theta) = \frac{r^n}{n\rho^{n-1}} (\alpha_n \cos n\theta + \sin n\theta)$$

$$u(r, \theta) = c + \sum_{n=1}^{\infty} \frac{r^n}{n\rho^{n-1}} (\alpha_n \cos n\theta + \beta_n \sin n\theta) \quad \alpha_n = \frac{1}{\pi} \int_{-\pi}^{\pi} f(\theta) \cos n\theta d\theta,$$

$$\beta_n = \frac{1}{\pi} \int_{-\pi}^{\pi} f(\theta) \sin n\theta d\theta, \quad n = 1, 2, 3, \dots$$

**Section 13.1 Answers, pp. 684–686**

$$13.1.2 \text{ (p. 684)} \quad y = -x + \frac{2}{e-1} (e^x - e^{(x-1)}) \quad 13.1.3 \text{ (p. 684)} \quad y = x^2 - \frac{x^3}{3} + cx \text{ with } c \text{ arbitrary}$$

$$13.1.4 \text{ (p. 684)} \quad y = -x + 2e^x + e^{-(x-1)} \quad 13.1.5 \text{ (p. 684)} \quad y = \frac{1}{4} + \frac{11}{4} \cos 2x + \frac{9}{4} \sin 2x$$

$$13.1.6 \text{ (p. 684)} \quad y = (x^2 + 13 - 8x)e^x \quad 13.1.7 \text{ (p. 684)} \quad y = 2e^{2x} + \frac{3(5e^{3x} - 4e^{4x})}{e(15 - 16e)} + \frac{2e^4(4e^{3(x-1)} - 3e^{4(x-1)})}{16e - 15}$$

$$13.1.8 \text{ (p. 684)} \quad \int_a^b tF(t) dt = 0 \quad y = -x \int_x^1 F(t) dt - \int_0^x tF(t) dt + c_1 x \text{ with } c_1 \text{ arbitrary}$$

$$13.1.9 \text{ (p. 685)} \quad \text{(a)} \quad b - a \neq k\pi \quad (k = \text{integer})$$

$$y = \frac{\sin(x-a)}{\sin(b-a)} \int_x^b F(t) \sin(t-b) dt + \frac{\sin(x-b)}{\sin(b-a)} \int_a^x F(t) \sin(t-a) dt$$

$$\text{(b)} \quad \int_a^b F(t) \sin(t-a) dt = 0$$

$$y = -\sin(x-a) \int_x^b F(t) \cos(t-a) dt - \cos(x-a) \int_a^x F(t) \sin(t-a) dt + c_1 \sin(x-a) \text{ with } c_1 \text{ arbitrary}$$

$$13.1.10 \text{ (p. 685)} \quad \text{(a)} \quad b - a \neq (k + 1/2)\pi \quad (k = \text{integer})$$

$$y = -\frac{\sin(x-a)}{\cos(b-a)} \int_x^b F(t) \cos(t-b) dt - \frac{\cos(x-b)}{\cos(b-a)} \int_a^x F(t) \sin(t-a) dt$$

$$\text{(b)} \quad \int_a^b F(t) \sin(t-a) dt = 0$$

$$y = -\sin(x-a) \int_x^b F(t) \cos(t-a) dt - \cos(x-a) \int_a^x F(t) \sin(t-a) dt + c_1 \sin(x-a) \text{ with } c_1 \text{ arbitrary}$$

$$13.1.11 \text{ (p. 685)} \quad \text{(a)} \quad b - a \neq k\pi \quad (k = \text{integer})$$

$$y = \frac{\cos(x-a)}{\sin(b-a)} \int_x^b F(t) \cos(t-b) dt + \frac{\cos(x-b)}{\sin(b-a)} \int_a^x F(t) \cos(t-a) dt$$

$$\text{(b)} \quad \int_a^b F(t) \cos(t-a) dt = 0$$

$$y = \cos(x-a) \int_x^b F(t) \sin(t-a) dt + \sin(x-a) \int_a^x F(t) \cos(t-a) dt + c_1 \cos(x-a) \text{ with } c_1 \text{ arbitrary}$$

$$13.1.12 \text{ (p. 685)} \quad y = \frac{\sinh(x-a)}{\sinh(b-a)} \int_x^b F(t) \sinh(t-b) dt + \frac{\sinh(x-b)}{\sinh(b-a)} \int_a^x F(t) \sinh(t-a) dt$$

$$13.1.13 \text{ (p. 685)} \quad y = -\frac{\sinh(x-a)}{\cosh(b-a)} \int_x^b F(t) \cosh(t-b) dt - \frac{\cosh(x-b)}{\cosh(b-a)} \int_a^x F(t) \sinh(t-a) dt$$

$$13.1.14 \text{ (p. 685)} \quad y = -\frac{\cosh(x-a)}{\sinh(b-a)} \int_x^b F(t) \cosh(t-b) dt - \frac{\cosh(x-b)}{\sinh(b-a)} \int_a^x F(t) \cosh(t-a) dt$$

$$13.1.15 \text{ (p. 685)} \quad y = -\frac{1}{2} \left( e^x \int_x^b e^{-t} F(t) dt + e^{-x} \int_a^x e^t F(t) dt \right)$$

13.1.16 (p. 685) If  $\omega$  isn't a positive integer, then

$$y = \frac{1}{\omega \sin \omega \pi} \left( \sin \omega x \int_x^\pi F(t) \sin \omega(t-\pi) dt + \sin \omega(x-\pi) \int_0^x F(t) \sin \omega t dt \right).$$

If  $\omega = n$  (positive integer), then  $\int_0^\pi F(t) \sin nt dt = 0$  is necessary for existence of a solution. In this case,

$$y = -\frac{1}{n} \left( \sin nx \int_x^\pi F(t) \cos nt dt + \cos nx \int_0^x F(t) \sin nt dt \right) + c_1 \sin nx$$

with  $c_1$  arbitrary.

13.1.17 (p. 685) If  $\omega \neq n + 1/2$  ( $n = \text{integer}$ ), then

$$y = -\frac{\sin \omega x}{\omega \cos \omega \pi} \int_x^\pi F(t) \cos \omega(t-\pi) dt - \frac{\cos \omega(x-\pi)}{\omega \cos \omega \pi} \int_0^x F(t) \sin \omega t dt.$$

If  $\omega = n + 1/2$  ( $n = \text{integer}$ ), then  $\int_0^\pi F(t) \sin(n+1/2)t dt = 0$  is necessary for existence of a solution. In this case,

$$y = -\frac{\sin(n+1/2)x}{n+1/2} \int_x^\pi F(t) \cos(n+1/2)t dt - \frac{\cos(n+1/2)x}{n+1/2} \int_0^x F(t) \sin(n+1/2)t dt + c_1 \sin(n+1/2)x$$

with  $c_1$  arbitrary,

13.1.18 (p. 685) If  $\omega \neq n + 1/2$  ( $n = \text{integer}$ ), then

$$y = \frac{\cos \omega x}{\omega \cos \omega \pi} \int_x^\pi F(t) \sin \omega(t-\pi) dt + \frac{\sin \omega(x-\pi)}{\omega \cos \omega \pi} \int_0^x F(t) \cos \omega t dt.$$

If  $\omega = n + 1/2$  ( $n = \text{integer}$ ), then  $\int_0^\pi F(t) \cos(n+1/2)t dt = 0$  is necessary for existence of a solution. In this case,

$$y = \frac{\cos(n+1/2)x}{n+1/2} \int_x^\pi F(t) \sin(n+1/2)t dt + \frac{\sin(n+1/2)x}{n+1/2} \int_0^x F(t) \cos(n+1/2)t dt + c_1 \cos(n+1/2)x$$

with  $c_1$  arbitrary.

13.1.19 (p. 685) If  $\omega$  isn't a positive integer, then

$$y = \frac{1}{\omega \sin \omega \pi} \left( \cos \omega x \int_x^\pi F(t) \cos \omega(t-\pi) dt + \cos \omega(x-\pi) \int_0^x F(t) \cos \omega t dt \right).$$

If  $\omega = n$  (positive integer), then  $\int_0^\pi F(t) \cos nt \, dt = 0$  is necessary for existence of a solution. In this case,

$$y = -\frac{1}{n} \left( \cos nx \int_x^\pi F(t) \sin nt \, dt + \sin nx \int_0^x F(t) \cos nt \, dt \right) + c_1 \cos nx$$

with  $c_1$  arbitrary.

**13.1.20 (p. 685)**  $y_1 = B_1(z_2)z_1 - B_1(z_1)z_2$

**13.1.21 (p. 685) (a)**  $G(x, t) = \begin{cases} \frac{(t-a)(x-b)}{b-a} & a \leq t \leq x, \\ \frac{(x-a)(t-b)}{b-a} & x \leq t \leq b \end{cases}$

$$y = \frac{1}{b-a} \left( (x-a) \int_x^b (t-b)F(t) \, dt + (x-b) \int_a^x (t-a)F(t) \, dt \right)$$

(b)  $G(x, t) = \begin{cases} a-t & a \leq t \leq x \\ a-x & x \leq t \leq b \end{cases} \quad y = (a-x) \int_x^b F(t) \, dt + \int_a^x (a-t)F(t) \, dt$

(c)  $G(x, t) = \begin{cases} x-b & a \leq t \leq x \\ t-b & x \leq t \leq b \end{cases} \quad y = \int_x^b (t-b)F(t) \, dt + (x-b) \int_a^x F(t) \, dt$

(d)  $\int_a^b F(t) \, dt = 0$  is a necessary condition for existence of a solution. Then

$$y = \int_x^b tF(t) \, dt + x \int_a^x F(t) \, dt + c_1 \text{ with } c_1 \text{ arbitrary.}$$

**13.1.22 (p. 686)**  $G(x, t) = \begin{cases} -\frac{(2+t)(3-x)}{5}, & 0 \leq t \leq x, \\ -\frac{(2+x)(3-t)}{5}, & x \leq t \leq 1 \end{cases} \quad \text{(a) } y = \frac{x^2 - x - 2}{2} \quad \text{(b) } y = \frac{5x^2 - 7x - 14}{30}$

(c)  $y = \frac{5x^4 - 9x - 18}{60}$

**13.1.23 (p. 686)**  $G(x, t) = \begin{cases} \frac{\cos t \sin x}{t^{3/2} \sqrt{x}}, & \frac{\pi}{2} \leq t \leq x, \\ \frac{\cos x \sin t}{t^{3/2} \sqrt{x}}, & x \leq t \leq \pi \end{cases}$

(a)  $y = \frac{1 + \cos x - \sin x}{\sqrt{x}} \quad \text{(b) } y = \frac{x + \pi \cos x - \pi/2 \sin x}{\sqrt{x}}$

**13.1.24 (p. 686)**  $G(x, t) = \begin{cases} \frac{(t-1)x(x-2)}{t^3}, & 1 \leq t \leq x, \\ \frac{x(x-1)(t-2)}{t^3}, & x \leq t \leq 2 \end{cases}$

(a)  $y = x(x-1)(x-2) \quad \text{(b) } y = x(x-1)(x-2)(x+3)$

**13.1.25 (p. 686)**  $G(x, t) = \begin{cases} -\frac{1}{22} \left( 3 + \frac{1}{t^2} \right) \left( x + \frac{4}{x} \right), & 1 \leq x \leq t, \\ -\frac{1}{22} \left( 3x + \frac{1}{x} \right) \left( 1 + \frac{4}{t^2} \right), & x \leq t \leq 2 \end{cases}$

(a)  $y = \frac{x^2 - 11x + 4}{11x} \quad \text{(b) } y = \frac{11x^3 - 45x^2 - 4}{33x} \quad \text{(c) } y = \frac{11x^4 - 139x^2 - 28}{88x}$

$$13.1.26 \text{ (p. 686)} \quad \alpha(\rho + \delta) - \beta\rho \neq 0 \quad G(x, t) = \begin{cases} \frac{(\beta - \alpha t)(\rho + \delta - \rho x)}{\alpha(\rho + \delta) - \beta\rho}, & 0 \leq t \leq x, \\ \frac{(\beta - \alpha x)(\rho + \delta - \rho t)}{\alpha(\rho + \delta) - \beta\rho}, & x \leq t \leq 1 \end{cases}$$

$$13.1.27 \text{ (p. 686)} \quad \alpha\delta - \beta\rho \neq 0 \quad G(x, t) = \begin{cases} \frac{(\beta \cos t - \alpha \sin t)(\delta \cos x - \rho \sin x)}{\alpha\delta - \beta\rho}, & 0 \leq t \leq x, \\ \frac{(\beta \cos x - \alpha \sin x)(\delta \cos t - \rho \sin t)}{\alpha\delta - \beta\rho}, & x \leq t \leq \pi \end{cases}$$

$$13.1.28 \text{ (p. 686)} \quad \alpha\rho + \beta\delta \neq 0 \quad G(x, t) = \begin{cases} \frac{(\beta \cos t - \alpha \sin t)(\rho \cos x + \delta \sin x)}{\alpha\rho + \beta\delta} & x \leq t \leq \pi \\ \frac{(\beta \cos x - \alpha \sin x)(\rho \cos t + \delta \sin t)}{\alpha\rho + \beta\delta} & 0 \leq t \leq x \end{cases}$$

$$13.1.29 \text{ (p. 686)} \quad \alpha\delta - \beta\rho \neq 0 \quad G(x, t) = \begin{cases} \frac{e^{x-t}(\beta \cos t - (\alpha + \beta) \sin t)(\delta \cos x - (\rho + \delta) \sin x)}{\alpha\delta - \beta\rho} & 0 \leq t \leq x, \\ \frac{e^{x-t}(\beta \cos x - (\alpha + \beta) \sin x)(\delta \cos t - (\rho + \delta) \sin t)}{\alpha\delta - \beta\rho}, & x \leq t \leq \pi \end{cases}$$

$$13.1.30 \text{ (p. 686)} \quad \beta\delta + (\alpha + \beta)(\rho + \delta) \neq 0 \quad G(x, t) = \begin{cases} \frac{e^{x-t}(\beta \cos t - (\alpha + \beta) \sin t)((\rho + \delta) \cos x + \delta \sin x)}{\beta\delta + (\alpha + \beta)(\rho + \delta)}, & 0 \leq t \leq x, \\ \frac{e^{x-t}(\beta \cos x - (\alpha + \beta) \sin x)((\rho + \delta) \cos t + \delta \sin t)}{\beta\delta + (\alpha + \beta)(\rho + \delta)}, & x \leq t \leq \pi/2 \end{cases}$$

$$13.1.31 \text{ (p. 686)} \quad (\rho + \delta)(\alpha - \beta)e^{(b-a)} - (\rho - \delta)(\alpha + \beta)e^{(a-b)} \neq 0$$

$$G(x, t) = \begin{cases} \frac{((\alpha - \beta)e^{(t-a)} - (\alpha + \beta)e^{-(t-a)})(\rho - \delta)e^{(x-b)} - (\rho + \delta)e^{-(x-b)}}{2[(\rho + \delta)(\alpha - \beta)e^{(b-a)} - (\rho - \delta)(\alpha + \beta)e^{(a-b)}]}, & 0 \leq t \leq x, \\ \frac{((\alpha - \beta)e^{(x-a)} - (\alpha + \beta)e^{-(x-a)})(\rho - \delta)e^{(t-b)} - (\rho + \delta)e^{-(t-b)}}{2[(\rho + \delta)(\alpha - \beta)e^{(b-a)} - (\rho - \delta)(\alpha + \beta)e^{(a-b)}]} & x \leq t \leq \pi \end{cases}$$

## Section 13.2 Answers, pp. 696–700

$$13.2.1 \text{ (p. 696)} \quad (e^{bx}y')' + ce^{bx}y = 0 \quad 13.2.2 \text{ (p. 696)} \quad (xy')' + \left(x - \frac{\nu^2}{x}\right)y = 0 \quad 13.2.3 \text{ (p. 696)} \quad (\sqrt{1-x^2}y')' + \frac{\alpha^2}{\sqrt{1-x^2}}y = 0$$

$$13.2.4 \text{ (p. 696)} \quad (x^b y')' + cx^{b-2}y = 0 \quad 13.2.5 \text{ (p. 696)} \quad (e^{-x^2}y')' + 2\alpha e^{-x^2}y = 0 \quad 13.2.6 \text{ (p. 696)} \quad (xe^{-x}y')' + \alpha e^{-x}y = 0$$

$$13.2.7 \text{ (p. 696)} \quad ((1-x^2)y')' + \alpha(\alpha+1)y = 0$$

$$13.2.9 \text{ (p. 696)} \quad \lambda_n = n^2\pi^2, \quad y_n = e^{-x} \sin n\pi x \quad (n = \text{positive integer})$$

$$13.2.10 \text{ (p. 697)} \quad \lambda_0 = -1, y_0 = 1 \quad \lambda_n = n^2\pi^2, y_n = e^{-x}(n\pi \cos n\pi x + \sin n\pi x) \quad (n = \text{positive integer})$$

$$13.2.11 \text{ (p. 697)} \quad \text{(a)} \lambda = 0 \text{ is an eigenvalue } y_0 = 2 - x \quad \text{(b)} \text{ none} \quad \text{(c)} 5.0476821, 14.9198790, 29.7249673, 49.4644528 \quad y = 2\sqrt{\lambda} \cos \sqrt{\lambda}x - \sin \sqrt{\lambda}x$$

$$13.2.12 \text{ (p. 697)} \quad \text{(a)} \lambda = 0 \text{ isn't an eigenvalue} \quad \text{(b)} -0.5955245 \quad y = \cosh \sqrt{-\lambda}x \quad \text{(c)} 8.8511386, 38.4741053, 87.8245457, 156.9126094 \quad y = \cos \sqrt{\lambda}x$$

$$13.2.13 \text{ (p. 697)} \quad \text{(a)} \lambda = 0 \text{ isn't an eigenvalue} \quad \text{(b)} \text{ none} \quad \text{(c)} 0.1470328, 1.4852833, 4.5761411, 9.6059439 \quad y = \sqrt{\lambda} \cos \sqrt{\lambda}x + \sin \sqrt{\lambda}x$$

$$13.2.14 \text{ (p. 697)} \quad \text{(a)} \lambda = 0 \text{ isn't an eigenvalue} \quad \text{(b)} -0.1945921 \quad y = 2\sqrt{-\lambda} \cosh \sqrt{-\lambda}x - \sinh \sqrt{-\lambda}x \quad \text{(c)} 1.9323619, 5.9318981, 11.9317920, 19.9317507 \quad y = 2\sqrt{\lambda} \cos \sqrt{\lambda}x - \sin \sqrt{\lambda}x$$

- 13.2.15 (p. 697)** (a)  $\lambda = 0$  isn't an eigenvalue (b)  $-1.0664054$   $y = \cosh \sqrt{-\lambda} x$  (c) 1.5113188, 8.8785880, 21.2104662, 38.4805610  $y = \cos \sqrt{\lambda} x$
- 13.2.16 (p. 697)** (a)  $\lambda = 0$  isn't an eigenvalue (b)  $-1.0239346$   
 $y = \sqrt{-\lambda} \cosh \sqrt{-\lambda} x - \sinh \sqrt{-\lambda} x$  (c) 2.0565705, 9.3927144, 21.7169130, 38.9842177  $y = \sqrt{\lambda} \cos \sqrt{\lambda} x - \sin \sqrt{\lambda} x$
- 13.2.17 (p. 697)** (a)  $\lambda = 0$  isn't an eigenvalue (b)  $-0.4357577$ ,  
 $y = 2\sqrt{-\lambda} \cosh \sqrt{-\lambda} x - \sinh \sqrt{-\lambda} x$  (c) 0.3171423, 3.7055350, 9.1970150, 16.8760401  $y = 2\sqrt{\lambda} \cos \sqrt{\lambda} x - \sin \sqrt{\lambda} x$
- 13.2.18 (p. 697)** (a)  $\lambda = 0$  isn't an eigenvalue (b)  $-2.1790546$ ,  $-9.0006633$   
 $y = \sqrt{-\lambda} \cosh \sqrt{-\lambda} x - 3 \sinh \sqrt{-\lambda} x$   
 (c) 5.8453181, 17.9260967, 35.1038567, 57.2659330  $y = \sqrt{\lambda} \cos \sqrt{\lambda} x - 3 \sin \sqrt{\lambda} x$
- 13.2.19 (p. 697)** (a)  $\lambda = 0$  is an eigenvalue  $y_0 = 2 - x$  (b)  $-1.0273046$   
 $y = 2\sqrt{-\lambda} \cosh \sqrt{-\lambda} x - \sinh \sqrt{-\lambda} x$  (c) 8.8694608, 16.5459202, 26.4155505, 38.4784094  $y = 2\sqrt{\lambda} \cos \sqrt{\lambda} x - \sin \sqrt{\lambda} x$
- 13.2.20 (p. 697)** (a)  $\lambda = 0$  isn't an eigenvalue (b)  $-7.9394171$ ,  $-3.1542806$   
 $y = 2\sqrt{-\lambda} \cosh \sqrt{-\lambda} x - 5 \sinh \sqrt{-\lambda} x$  (c) 29.3617465, 78.777456, 147.8866417, 236.7229622  $y = 2\sqrt{\lambda} \cos \sqrt{\lambda} x - 5 \sin \sqrt{\lambda} x$
- 13.2.21 (p. 697)**  $\lambda = 0$ ,  $y = xe^{-x}$  20.1907286, 118.8998692, 296.5544121, 553.1646458  
 $y = e^{-x} \sin \sqrt{\lambda} x$
- 13.2.22 (p. 697)**  $\lambda_n = n^2 \pi^2$ ,  $y_n = x \sin n\pi(x - 2)$  ( $n =$  positive integer)
- 13.2.23 (p. 697)**  $\lambda = 0$ ,  $y = x(2 - x)$  20.1907286, 118.8998692, 296.5544121  
 553.1646458,  $y = x \sin \sqrt{\lambda}(x - 2)$
- 13.2.24 (p. 698)** 3.3730893, 23.1923372, 62.6797232, 121.8999231, 200.8578309  
 $y = x \sin \sqrt{\lambda}(x - 1)$
- 13.2.25 (p. 698)** (a)  $-L < \delta < 0$  (b)  $\delta = -L$
- 13.2.26 (p. 698)**  $\lambda_0 = -1/\alpha^2$   $y_0 = e^{-x/\alpha}$   $\lambda_n = n^2$ ,  $y_n = n\alpha \cos nx - \sin nx$ ,  $n = 1, 2, \dots$
- 13.2.27 (p. 698)** (a)  $y = x - \alpha$  (b)  $y = \alpha k \cosh kx - \sin kx$  (c)  $y = \alpha k \cos kx - \sin kx$
- 13.2.29 (p. 698)** (b)  $\lambda = -\alpha^2/\beta^2$   $y = e^{-\alpha x/\beta}$





# Index

## A

- Abel's formula, 199–202, 468
- Accelerated payment, 139
- Acceleration due to gravity, 151
- Airy's equation, 319
- Amplitude,
  - of oscillation, 271
  - time-varying, 279
- Amplitude–phase form, 272
- Aphelion distance, 300
- Apogee, 300
- Applications,
  - of first order equations, 130–192
    - autonomous second order equations, 162–179
    - cooling problems, 140–141
    - curves, 179–192
    - elementary mechanics, 151–177
    - growth and decay, 130–140
    - mixing problems, 143–150
  - of linear second order equations, 268–302
    - motion under a central force, 295–302
    - motion under inverse square law force, 299–301
    - RLC* circuit, 289–295
    - spring–mass systems, 268–289
- Autonomous second order equations, 162–183
  - conversion to first order equations, 162
  - damped 173–178
    - pendulum 174
    - spring–mass system, 173
  - Newton's second law of motion and, 163
  - undamped 164–172
    - pendulum 173–169
    - spring–mass system, 164–173
  - stability and instability conditions for, 170–178

## B

- Beat, 275
- Bernoulli's equation, 63–64

- Bessel functions of order  $\nu$ , 360
- Bessel's equation, 205 287, 348
  - of order  $\nu$ , 360
  - of order zero, 377
  - ordinary point of, 319
  - singular point of, 319, 342
- Bifurcation value, 54, 176
- Birth rate, 2
- Boundary conditions, 580
  - in heat equation, 618
  - Laplace equation, 649–651
  - periodic, 580
  - separated, 676
  - for two-point boundary value problems, 676
- Boundary points, 676
- Boundary value problems, 618
  - initial-, 618
  - mixed, 649
  - two-point, 676–686
    - assumptions, 676
    - boundary conditions for, 676
    - defined, 676
    - Green's functions for, 681
    - homogeneous and nonhomogeneous, 676
    - orthogonality and, 583
- Capacitance, 290
- Capacitor, 290
- Carbon dating, 136
- Central force,
  - motion under a, 295–302
  - in terms of polar coordinates,
- Characteristic equation, 210
  - with complex conjugate roots, 214–217
  - with distinct real roots, 211–217
  - with repeated real root, 212, 217
- Characteristic polynomial, 210, 340, 475
- Charge, 290
  - steady state, 293
- Chebyshev polynomials, 322
- Chebyshev's equation, 322

- Circuit, *RLC*. *See RLC* circuit
- Closed Circuit, 289
- Coefficient(s) *See also* Constant coefficient equations  
 computing recursively, 322  
 Fourier, 587  
 in Frobenius solutions, 352–358  
 undetermined, method of, 229–248, 475–496  
 principle of superposition and, 235
- Coefficient matrix, 516, 516
- Competition, species, 6, 541
- Complementary equation, 35, 469
- Complementary system, 568
- Compound interest, continuous, 131, 134
- Constant,  
 damping, 173  
 decay, 130  
 separation, 619  
 spring, 268  
 temperature decay, 140
- Constant coefficient equations, 210, 475  
 homogeneous, 210–221  
 with complex conjugate roots, 214–217  
 with distinct real roots, 211, 217  
 higher order. *See* Higher order constant coefficient homogeneous equations  
 with repeated real roots, 212, 217  
 with impulses, 452–460  
 nonhomogeneous, 229–248  
 with piecewise continuous forcing functions, 430–439
- Constant coefficient homogeneous linear systems of differential equations, 529–568  
 geometric properties of solutions,  
 when  $n = 2$ , 536–539, 551–554, 562–565  
 with complex eigenvalue of constant matrix, 556–565  
 with defective constant matrix, 558–556  
 with linearly independent eigenvectors, 529–541
- Constant solutions of separable first order equations, 48–53
- Converge absolutely, 307
- Convergence,  
 of improper integral, 393  
 open interval of, 306  
 radius of, 306
- Convergent infinite series, 620
- Convergent power series, 306
- Convolution, 440–452  
 convolution integral, 445–450  
 defined, 441  
 theorem, 441  
 transfer functions, 446–448  
 Volterra integral equation, 445
- Cooling, Newton's law of, 3, 140
- Cooling problems, 140–141, 148–148
- Cosine series, Fourier, 603–604  
 mixed, 606–608
- Critically damped motion, 280–281  
 oscillation, 291–294
- Critical point, 163
- Current, 289  
 steady state, 293  
 transient, 293
- Curves, 179–192  
 equipotential, 185  
 geometric problems, 183  
 isothermal, 185  
 one-parameter families of, 179–183 subsubitem  
 defined, 179  
 differential equation for, 180  
 orthogonal trajectories, 190–190, 192  
 finding, 186–190
- D**
- D'Alembert's solution, 637
- Damped autonomous second order equations, 172–179  
 for pendulum, 174  
 for spring-mass system, 173
- Damped motion, 268
- Damping,  
*RLC* circuit in forced oscillation with, 293  
 spring-mass systems with, 173, 268, 279–288  
 critically damped motion, 280–283  
 forced vibrations, 283–287  
 free vibrations, 279–283  
 overdamped motion, 279  
 underdamped motion, 279  
 spring-mass systems without, 269–277  
 forced oscillation, 273–277
- Damping constant, 173
- Damping forces, 163, 268
- Dashpot, 268
- Dating, carbon, 135–136
- Death rate 3
- Decay, *See* Exponential growth and decay,
- Decay constant, 130
- Derivatives, Laplace transform of, 413–415
- Differential equations,  
 defined, 8  
 order of, 8  
 ordinary, 8  
 partial, 8  
 solutions of, 9–11
- Differentiation of power series, 308
- Dirac, Paul A. M., 452

- Dirac delta function, 452
- Direction fields for first order equations, 16–27
- Dirichlet, Peter G. L., 662
- Dirichlet condition, 662
- Dirichlet problem, 662
- Discontinuity,
  - jump, 398
  - removable, 408
- Distributions, theory of, 453
- Divergence of improper integral, 393
- Divergent power series, 306
- E**
- Eccentricity of orbit, 300
- Eigenfunction associated with  $\lambda$ , 580, 689
- Eigenvalue, 580, 689
- Eigenvalue problems, *See also* Boundary value problems
  - Sturm-Liouville problems, 686–700
    - defined, 689
    - orthogonality in, 695
    - solving, 688
- Elliptic orbit, 300
- Epidemics 5–53
- Equidimensional equation, 486
- Equilibrium, 163
  - spring-mass system, 268
- Equilibrium position, 268
- Equipotentials, 185
- Error(s),
  - in applying numerical methods, 96
  - in Euler's method, 97–102
  - at the  $i$ -th step, 96
  - truncation, 96
    - global, 102, 111, 119
    - local, 100
    - local, numerical methods with  $O(h^3)$ , 114–116
- Escape velocity, 159
- Euler's equation, 343–346, 229
- Euler's identity, 96–108
- Euler's method, 96–108
  - error in, 97–100
    - truncation, 100–102
  - improved, 109–114
  - semilinear, 102–106
  - step size and accuracy of, 97
- Even functions, 592
- Exact first order equations, 73–82
  - implicit solutions of, 73–74
  - procedures for solving, 76
- Exactness condition, 75
- Existence of solutions of nonlinear first order equations, 56–62
- Existence theorem, 40, 56
- Exponential growth and decay, 130–140
  - carbon dating, 136
  - interest compounded continuously, 134
  - mixed growth and decay, 134
  - radioactive decay, 130
  - savings program, 136
- Exponential order, function of, 400
- F**
- First order equations, 31–93
  - applications of *See under* Applications.
  - autonomous second order equation converted to, 162
  - direction fields for, 16–20
  - exact, 73–82
    - implicit solution of, 73
    - procedures for solving, 76
  - linear, 31–44
    - homogeneous, 106–35
    - nonhomogeneous, 35–41
    - solutions of, 30
  - nonlinear, 41, 52, 56–72
    - existence and uniqueness of solutions of, 56–62
    - transformation into separables, 62–72
  - numerical methods for solving. *See* Numerical method
  - separable, 45–55, 68–72
    - constant solutions of, 48–50
    - implicit solutions of, 47–48
- First order systems of equations,
  - higher order systems written as, 511
  - scalar differential equations written as, 512
- First shifting theorem, 397
- Force(s)
  - damping, 163, 268
  - gravitational, 151, 158
  - impulsive, 453
  - lines of, 185
  - motion under central, 296–302
  - motion under inverse square law, 299–302
- Forced motion, 268
  - oscillation
    - damped, 293–294
    - undamped, 273–277
  - vibrations, 283–287
- Forcing function, 194
  - without exponential factors, 516, 516 487–494
  - with exponential factors, 244–244

- piecewise continuous constant equations with, 430–439
  - Fourier coefficients, 587
  - Fourier series, 586–616
    - convergence of, 589
    - cosine series, 603–604
      - convergence of, 607
      - mixed, 606
    - defined 588
    - even and odd functions, 592–589
    - sine series, 605
      - convergence of, 605
      - mixed, 609
  - Fourier solutions of partial differential equations, 618–673
    - heat equation, 618–629
      - boundary conditions in, 618
      - defined, 618
      - formal and actual solutions of, 620
      - initial-boundary value problem, 618–625
      - initial condition, 618
      - nonhomogeneous problems, 623–625
      - separation of variables to solve, 618–620
  - Laplace’s equation, 649–673
    - boundary conditions, 649–662
    - defined, 649
    - formal solutions of, 651–662
    - in polar coordinates, 666–673
    - for semiinfinite strip, 660
  - Free fall under constant gravity, 13
  - Free motion, 268
    - oscillation, *RLC* circuit in, 291–292
    - vibrations, 279–283
  - Frequency, 279
    - of simple harmonic motion, 292
  - Frobenius solutions, 347–390
    - indicial equation with distinct real roots differing by an integer, 378–390
    - indicial equation with distinct real roots not differing by an integer, 351–364
    - indicial equation with repeated root, 364–378
    - power series in, 348
    - recurrence relationship in, 350
      - two term, 353–355
    - verifying, 357
  - Function(s)
    - even and odd, 592
    - piecewise smooth, 588
  - Fundamental matrix, 524
  - Fundamental set of solutions, of higher order constant coefficient homogeneous equations, 480–482
    - of homogeneous linear second order equations, 198, 202
    - of homogeneous linear systems of differential equations, 522, 524
    - of linear higher order equations, 466
- G**
- Gamma function, 403
  - Generalized Riccati equation, 72, 255
  - General solution
    - of higher order constant coefficient homogeneous equations, 475–480
    - of homogeneous linear second order equations, 198
    - of homogeneous linear systems of differential equations, 521, 524
    - of linear higher order equations, 465, 469
    - of nonhomogeneous linear first order equations, 30, 40
    - of nonhomogeneous linear second order equations, 221, 248–255
  - Geometric problems, 235–184
  - Gibbs phenomenon, 589, 597
  - Global truncation error in Euler’s method, 102
  - Glucose absorption by the body, 5
  - Gravitation, Newton’s law of, 151, 176, 295, 510, 515
  - Gravity, acceleration due to, 151
  - Green’s function, 504, 681, 682, 685–686
  - Grid, rectangular, 17
  - Growth and decay,
    - carbon dating, 136
    - exponential, 130–140
    - interest compounded continuously, 133–134
    - mixed growth and decay, 134
    - radioactive decay, 130
    - savings program, 136
- H**
- Half-life, 130
  - Half-line, 536
  - Half-plane, 552
  - Harmonic conjugate function, 82
  - Harmonic function, 82
  - Harmonic motion, simple, 166, 271 292, 292
    - amplitude of oscillation, 272
    - natural frequency of, 272
    - phase angle of, 272
  - Heat equation, 618–629
    - boundary conditions in, 618
    - defined, 618
    - formal and actual solutions of, 620
    - initial-boundary value problems, 618, 625
    - initial condition, 618
    - nonhomogeneous problems, 623–625

- separation of variables to solve, 618
  - Heat flow lines, 185
  - Heaviside's method, 407, 412
  - Hermite's equation, 322
  - Heun's method, 116
  - Higher order constant coefficient homogeneous equations, 475–487
    - characteristic polynomial of, 482–478
    - fundamental sets of solutions of, 480
    - general solution of, 476–482
  - Homogeneous linear first order equations, 30–34
    - general solutions of, 33
    - separation of variables in, 35
  - Homogeneous linear higher order equations, 465
  - Homogeneous linear second order equations, 194–221
    - constant coefficient, 210–221
      - with complex conjugate roots, 214–217
      - with distinct real roots, 210–217
      - with repeated real roots, 210–214, 217
    - solutions of, 194, 198
    - the Wronskian and Abel's formula, 199–202
  - Homogeneous linear systems of differential equations, 516
    - basic theory of, 521–528
    - constant coefficient, 529–568
      - with complex eigenvalues of coefficient matrix, 556–568
      - with defective coefficient matrix, 542–551
      - geometric properties of solutions when  $n = 2$ , 529–539, 551–554, 562–565
      - with linearly independent eigenvectors, 529–539
        - subitem fundamental set of solutions of, 521, 524
      - general solution of, 521, 524
      - trivial and nontrivial solution of, 521
      - Wronskian of solution set of, 523
  - Homogeneous nonlinear equations
    - defined, 65
    - transformation into separable equations, 65–68
  - Hooke's law, 268–269
- I**
- Imaginary part, 215
  - Implicit function theorem, 47
  - Implicit solution(s) 73–74
    - of exact first order equations, 73–74
    - of initial value problems, 47
    - of separable first order equations, 47–49
  - Impressed voltage, 53
  - Improper integral, 393
  - Improved Euler method, 108–112 120–122
    - semilinear, 112–114
  - Impulse function, 452
  - Impulse response, 448, 455
  - Impulses, constant coefficient equations with, 452–461
  - Independence, linear
    - of  $n$  function, 466
    - of two functions, 198
    - of vector functions, 525
  - Indicial equation, 343, 351
    - with distinct real roots differing by an integer, 378–390
    - with distinct real roots not differing by an integer, 351–364
    - with repeated root, 364–378
  - Indicial polynomial, 343, 351
  - Inductance, 290
  - Infinite series, convergent, 620
  - Initial-boundary value problem, 618
    - heat equation, 618–625
    - wave equation, 630–649
  - Initial conditions, 11
  - Initial value problems, 11–14
    - implicit solution of, 47
    - Laplace transforms to solve, 413–419
      - formula for, 443–444
      - second order equations, 415–419
  - Integral curves, 9–9, 413–27,
  - Integrals,
    - convolution, 445–445
    - improper, 393
  - Integrating factors, 82–93
    - finding, 83–93
  - Interest compounded continuously, 131–134
  - Interval of validity, 12
  - Inverse Laplace transforms, 404–413
    - defined, 404
    - linearity property of, 405
    - of rational functions, 406–413
  - Inverse square law force, motion under, 299–301
  - Irregular singular point, 342
  - Isothermal curves, 185
- J**
- Jump discontinuity, 398
- K**
- Kepler's second law, 296
  - Kepler's third law, 301
  - Kirchoff's Law, 290
- L**
- Laguerre's equation, 348
  - Lambda-eigenfunctions, 580, 687
  - Laplace's equation, 649–673

- boundary conditions, 649–651
    - defined, 649
    - formal solutions of, 651–662
    - in polar coordinates, 666–673
    - for semi-infinite strip, 660
  - Laplace transforms, 393–461
    - computation of simple, 393–396
    - of constant coefficient equations
      - with impulses 452–461
      - with piecewise continuous forcing functions, 430–439
    - convolution, 440–452
      - convolution integral, 445
      - defined, 441
      - theorem, 441
      - transfer functions, 446–448
    - definition of, 393
    - existence of, 398
    - First shifting theorem, 397
    - inverse, 404
      - defined, 403
      - linearity property of, 405
      - of rational functions, 406–411
    - linearity of, 396
    - of piecewise continuous functions, 421–430
      - unit step function and, 419–430
    - Second shifting theorem, 425
    - to solve initial value problems, 413–419
      - derivatives, 413–415
      - formula for, 443–444
      - second order equations, 415
    - tables of, 396
  - Legendre's equation, 204, 319
    - ordinary points of, 319
    - singular points of, 319, 347
  - Limit, 398
  - Limit cycle, 176
  - Linear combination(s), 198, 465, 521
    - of power series, 313–316
  - Linear difference equations, second order homogeneous, 340
  - Linear first order equations, 30–44
    - homogeneous, 30–35
      - general solution of, 33
      - separation of variables, 35
    - nonhomogeneous, 30, 35–41
      - general solution of, 35–41
      - solutions in integral form, 38–39
      - variation of parameters to solve, 35, 38
    - solutions of, 30–31
  - Linear higher order equations, 465–505
    - fundamental set of solutions of, 465, 466
    - general solution of, 465, 469
  - higher order constant coefficient homogeneous equations, 475–487
    - characteristic polynomial of 475–480
    - fundamental sets of solutions of, 479–482
    - general solution of, 476–478
  - homogeneous, 465
  - nonhomogeneous, 465, 469
  - trivial and nontrivial solutions of, 465
  - undetermined coefficients for, 487–496
  - variation of parameters for, 497–505
    - derivation of method, 497–499
    - fourth order equations, 501–497
    - third order equations, 499
  - Wronskian of solutions of 467–469
- Linear independence 198
  - of  $n$  functions, 466
  - of two functions, 198
  - of vector functions, 521–523
- Linearity,
  - of inverse Laplace transform, 405
  - of Laplace transform, 396
- Linear second order equations, 194–264
  - applications of. *See under* Applications
  - defined, 194
  - homogeneous, 194–221
    - constant coefficient, 210–201
    - solutions of, 194–198
    - the Wronskian and Abel's formula, 199–202
  - nonhomogeneous, 194, 221–264, 465, 469
    - comparison of methods for solving, 203
    - complementary equation for, 221
    - constant coefficient, 229–248
    - general solution of, 221–225
    - particular solution of, 221, 225–227
    - reduction of order to find general solution of, 248–255
    - superposition principle and, 225–227
    - undetermined coefficients method for, 229–248
    - variation of parameters to find particular solution of, 255–264
  - series solutions of, 306–390
    - Euler's equation, 343–347
    - Frobenius solutions, 347–390
    - near an ordinary point, 319–339
    - with regular singular points, 342–347
- Linear systems of differential equations, 515–577
  - defined, 515
  - homogeneous, 515
    - basic theory of, 521–529
    - constant coefficient, 529–568
    - fundamental set of solutions of, 521–524
    - general solution of, 521, 524

- linear independence of, 521, 524
- trivial and nontrivial solution of, 521
- Wronskian of solution set of, 523
- nonhomogeneous, 516
  - variation of parameters for, 568–576
- solutions to initial value problem, 515–517
- Lines of force, 185
- Liouville, Joseph, 689
- local truncation error, 100–102
  - numerical methods with  $O(h^3)$ , 114–116
- Logistic equation 3
- M**
- Maclaurin series, 308
- Magnitude of acceleration due to gravity at Earth's surface, 151
- Malthusian model, 2
- Mathematical models, 2
  - validity of, 137, 140, 149
- Matrix/matrices, 516–518
  - coefficient,
    - complex eigenvalue of, 557–568
    - defective, 542
    - fundamental, 524
- Mechanics, elementary, 151–178
  - escape velocity, 158–159 162, 162
  - motion through resisting medium under constant gravitational force, 151–157
  - Newton's second law of motion, 151–151
  - pendulum motion
    - damped, 174–176
    - undamped, 173–169
  - spring-mass system
    - damped, 173–174, 269, 279–289
    - undamped, 164–173, 268
  - units used in, 151
- Midpoint method, 109
- Mixed boundary value problems, 649
- Mixed Fourier cosine series, 606–608
- Mixed Fourier sine series, 609
- Mixed growth and decay, 134
- Mixing problems, 143–148
- Models, mathematical, 2–3
  - validity of, 137, 140, 149
- Motion,
  - damped, 268
    - critically, 280
    - overdamped, 279–280
    - underdamped, 279
  - elementary, *See* Mechanics, elementary
  - equation of, 269
  - forced, 270
  - free, 270
- Newton's second law of, 6, 151–151, 163, 165, 173, 173–174, 268, 296, 510
  - autonomous second order equations and, 163
- simple harmonic, 166, 269–273
  - amplitude of oscillation, 271
  - frequency of, 272
  - phase angle of, 271
- through resisting medium under constant gravitational force, 152–157
- under a central force, 295–302
- under inverse square law force, 299–301
- undamped, 268
- Multiplicity, 479
- N**
- Natural frequency, 272
- Natural length of spring, 268
- Negative half plane, 552
- Neumann condition, 649
- Neumann problem, 649
- Newton's law of cooling, 3, 140–141, 148–150
- Newton's law of gravitation, 151, 176, 295, 510, 519
- Newton's second law of motion, 151–151, 163, 166, 173, 176, 268, 296, 509, 510
  - autonomous second order equations and, 163
- Nonhomogeneous linear second order equations, 30, 35, 41
  - general solution of, 35–38 40–41
  - solutions in integral form, 38
  - variation of parameters to solve, 35, 38
- Nonhomogeneous linear second order equations, 194, 221–264
  - comparison of methods for solving, 262
  - complementary equation for, 221, 221
  - constant coefficient, 229–255
  - general solution of, 221–225
  - particular solution of, 221, 221–226, 229–235, 255–262
  - reduction of order to find general solution of, 248–255
  - superposition principle and, 225–223
  - undetermined coefficients method for, 229–255
    - forcing functions with exponential factors, 242–244
    - forcing functions without exponential factors, 238–241
    - superposition principle and, 235
    - variation of parameters to find particular solution of, 255–264
- Nonhomogeneous linear systems of differential equations, 515
  - variation of parameters for, 568–577
- Nonlinear first order equations, 52 56–72

- existence and uniqueness of solutions of, 56–72
- transformation into separable equations, 62–72
- Nonoscillatory solution, 358
- Nontrivial solutions
  - of homogeneous linear first order equations, 30
  - of homogeneous linear higher order equations, 465
  - of homogeneous linear second order equations, 194
  - of homogeneous linear systems of differential equations, 521
- Numerical methods, 96–127, 514
  - with  $O(h^3)$  local truncation, 114–116
  - error in, 96
  - Euler’s method, 96–108
    - error in, 97–102
    - semilinear, 102–106
    - step size and accuracy of, 97
    - truncation error in, 99–102
  - Heun’s method, 115
    - semilinear, 106
  - improved Euler method, 106, 109–112
    - semilinear, 112
  - midpoint, 116
  - Runge-Kutta method, 98, 106, 119–127, 513–514
    - for cases where  $x_0$  isn’t the left endpoint, 122–124
    - semilinear, 106, 122
  - for systems of differential equations, 514
- Numerical quadrature, 119, 127
- O**
- Odd functions, 592
- One-parameter families of curves, 179–183
  - defined, 179
  - differential equation for, 180
- One-parameter families of functions, 30
- Open interval of convergence, 306
- Open rectangle, 56
- Orbit, 301
  - eccentricity of, 300
  - elliptic, 300
  - period of, 301
- Order of differential equation, 8
- Ordinary differential equation,
  - defined, 8
- Ordinary point, series solutions of linear second order equations near, 319–341
- Orthogonality, 583–581
  - in Sturm-Liouville problems, 695
- Orthogonal trajectories, 186–190,
  - finding, 186
- Orthogonal with respect to a weighting function, 331, 331
- Oscillation
  - amplitude of, 271
  - critically damped, 292
  - overdamped, 292
  - RLC* circuit in forced, with damping, 293–293
  - RLC* circuit in free, 291–293
  - undamped forced, 273–277
  - underdamped, 291
- Oscillatory solutions, 232–176, 347
- Overdamped motion, 279–279
- P**
- Partial differential equations
  - defined, 8
  - Fourier solutions of, 618–673
    - heat equation, 618–630
    - Laplace’s equation, 649–673
    - wave equation 630–649
- Partial fraction expansions, software packages to find, 411
- Particular solutions of nonhomogeneous higher equations, 469, 487–505
- Particular solutions of nonhomogeneous linear second order equations, 221, 225–226, 229–235, 255–261
- Particular solutions of nonhomogeneous linear systems equations, 568–577
- Pendulum
  - damped, 174–176
  - undamped, 173–169
- Perigee, 300
- Perihelion distance, 300
- Periodic functions, 404
- Period of orbit, 296
- Phase angle of simple harmonic motion, 271–272
- Phase plane equivalent, 162
- Piecewise continuous functions, 399
  - forcing, constant coefficient equations with, 430–439
- Piecewise smooth function, 588
  - Laplace transforms of 398–401, 421–430
  - unit step functions and, 419–430
- Plucked string, wave equation applied to, 638–642
- Poincaré, Henri, 162
- Polar coordinates
  - central force in terms of, 296–298
  - in amplitude-phase form, 271
  - Laplace’s equation in, 666–673
- Polynomial(s)
  - characteristic, 210, 340, 482



- of higher order constant coefficient homogeneous equations, 475–478
  - Chebyshev, 322
  - indicial, 343, 351
  - Taylor, 309
  - trigonometric, 602
- Polynomial operator, 475
- Population growth and decay, 2
- Positive half-plane, 552
- Potential equation, 649
- Power series, 306–319
  - convergent, 306–307
  - defined, 306
  - differentiation of, 308–309
  - divergent, 306
  - linear combinations of, 313–316
  - radius of convergence of, 306, 307
  - shifting summation index in, 310–312
  - solutions of linear second order equations, represented by, 319–341
  - Taylor polynomials, 309
  - Taylor series, 308
  - uniqueness of, 309–309
- Q**
- Quasi-period, 279
- R**
- Radioactive decay, 130–131
- Radius of convergence of power series, 306, 307
- Rational functions, inverse Laplace transforms of, 406–413
- Rayleigh, Lord, 171
- Rayleigh's equation, 177
- Real part, 215
- Rectangle, open, 56
- Rectangular grid, 17
- Recurrence relations, 322
  - in Frobenius solutions, 351
  - two term, 353–355
- Reduction of order, 213, 248–255
- Regular singular points, 342–347
  - at  $x_0 = 0$ , 347–364
- Removable discontinuity, 398
- Resistance, 290
- Resistor, 290
- Resonance, 277
- Ricatti, Jacopo Francesco, 72
- Ricatti equation, 72
- RLC circuit, 289–294
  - closed, 289
  - in forced oscillation with damping, 293
  - in free oscillation, 291–293
- Roundoff errors, 96
- Runge-Kutta method, 98, 119–127, 514
  - for cases where  $x_0$  isn't the left endpoint, 122
  - for linear systems of differential equations, 514
  - semilinear, 106, 122
- S**
- Savings program, growth of, 136
- Scalar differential equations, 512
- Second order differential equation, 6
  - autonomous, 162–178
    - conversion to first order equation, 162
    - damped, 173–178
    - Newton's second law of motion and, 163
    - undamped, 164–169
  - Laplace transform to solve, 415–418
  - linear, *See* linear second equations
  - two-point boundary value problems for, 676–686
    - assumptions, 676
    - boundary conditions for, 676
    - defined, 676
    - Green's function for, 682
    - homogeneous and nonhomogeneous, 676
    - procedure for solving, 677
- Second order homogeneous linear difference equation, 340
- Second shifting Theorem, 425–427
- Semilinear Euler method, 102
- Semilinear improved Euler method, 106, 112
- Semilinear Runge-Kutta method, 108, 124
- Separable first order equations, 45–55
  - constant solutions of, 48–50
  - implicit solutions, 47
  - transformations of nonlinear equations to, 62–63
    - Bernoulli's equation, 62–68
    - homogeneous nonlinear equations, 65–68
    - other equations, 64
- Separated boundary conditions, 676
- Separation constant, 619
- Separation of variables, 35, 45
  - to solve heat equation, 618
  - to solve Laplace's equation, 651–662, 667–673
  - to solve wave equation, 632
- Separatrix, 171, 170
- Series, power. *See* Power series
- Series solution of linear second order equations, 306–390
  - Frobenius solutions, 347–390
  - near an ordinary point, 319
- Shadow trajectory, 564–565
- Shifting theorem
  - first, 397

- second, 425–427
  - Simple harmonic motion, 269–273
    - amplitude of oscillation, 271
    - natural frequency of, 272
    - phase angle of, 272
  - Simpson's rule, 127
  - Singular point, 319
    - irregular, 342
    - regular, 342–347
  - Solution(s), 9–10 *See also* Frobenius solutions Non-trivial solutions Series solutions of linear second order equations Trivial solution
    - nonoscillatory, 358
    - oscillatory, 358
  - Solution curve, 9–9
  - Species, interacting, 6, 540
  - Spring, natural length of, 268, 269
  - Spring constant, 268
  - Spring-mass systems, 268–289
    - damped, 172, 269, 287–289
      - critically damped motion, 287–283
      - forced vibrations, 283–287
      - free vibrations, 283–285
      - overdamped motion, 279
      - underdamped motion, 279
    - in equilibrium, 268
    - simple harmonic motion, 269–273
      - amplitude of oscillation, 272
      - natural frequency of, 272
      - phase angle of, 272
    - undamped, 164–166, 269–277
      - forced oscillation, 273–287
  - Stability of equilibrium and critical point, 163–164
  - Steady state, 135
  - Steady state charge, 293
  - Steady state component, 285, 447
  - Steady state current, 293
  - String motion, wave equation applied to, 630–638
    - plucked, 638–642
    - vibrating, 630–638
  - Sturm-Liouville equation, 689
  - Sturm-Liouville expansion, 696
  - Sturm-Liouville problems, 687–700
    - defined, 687
    - orthogonality in, 695
    - solving, 687
  - Summation index in power series, 310–312
  - Superposition, principle of, 44, 225, 235, 470
    - method of undetermined coefficients and, 235
  - Systems of differential equations, 507–518 *See also*
    - Linear systems of differential equations
      - first order
        - higher order systems rewritten as, 322–512
        - scalar differential equations rewritten as, 512
        - numerical solutions of, 514
        - two first order equations in two unknowns, 507–510
- ## T
- Tangent lines, 181
  - Taylor polynomials, 309
  - Taylor Series, 308
  - Temperature, Newton's law of cooling, 3 140–141, 148–149
  - Temperature decay constant of the medium, 140
  - Terminal velocity, 152
  - Time-varying amplitude, 279
  - Total impulse, 452
  - Trajectory(ies),
    - of autonomous second order equations, 162
    - orthogonal, 186–190
      - finding, 186–244
    - shadow, 564
  - of  $2 \times 2$  systems, 536–539, 551–554, 562–565
  - Transfer functions, 446
  - Transformation of nonlinear equations to separable
    - first order, equations, 62–81
      - Bernoulli's equation, 63
      - homogeneous nonlinear equations, 65–68
      - other equations, 64
  - Transform pair, 393
  - Transient current, 293
  - Transient components, 285, 447
  - Transient solutions, 292
  - Trapezoid rule, 119
  - Trivial solution,
    - of homogeneous linear first order equations, 30
    - of homogeneous linear second order equations, 194
    - of homogeneous linear systems of differential equations, 521
    - of linear higher order differential equations, 465
  - Truncation error(s), 96
    - in Euler's method, 100
    - global, 102, 109
    - local, 100
      - numerical methods with  $O(h^3)$ , 114–116
  - Two-point boundary value problems, 676–686
    - assumptions, 676
    - boundary conditions for, 676
    - defined, 676
    - Green's function for, 681
    - homogeneous and nonhomogeneous, 677
- ## U

Undamped autonomous second order equations, 164–171  
 pendulum, 173–169  
 spring-mass system, 164–166  
 stability and instability conditions for, 170–171  
 Undamped motion, 268  
 Underdamped motion, 279  
 Underdamped oscillation, 291  
 Undetermined coefficients  
 for linear higher order equations, 487–496  
 forcing functions, 487–494  
 for linear second order equations, 229–248  
 principle of superposition, 235  
 Uniqueness of solutions of nonlinear first equations, 56–62  
 Uniqueness theorem, 40, 56, 194, 465, 516  
 Unit step function, 422–430

## V

Validity, interval of, 12  
 Vandermonde, 484  
 Vandermonde determinant, 484  
 van der Pol's equation, 176  
 Variables, separation of, 35, 45  
 Variation of parameters  
 for linear first order equations, 35  
 for linear higher order equations, 497–505  
 derivation of method, 497–498  
 fourth order equations, 501–502  
 third order equations, 499  
 for linear higher second order equations, 255  
 for nonhomogeneous linear systems of differential equations, 568–577  
 Velocity  
 escape, 158–151  
 terminal, 152–156  
 Verhulst, Pierre, 3  
 Verhulst model, 3, 27, 69  
 Vibrating strings, wave equation applied to, 630  
 Vibrations  
 forced, 283–287  
 free, 279–283  
 Voltage, impressed, 289  
 Voltage drop, 290  
 Volterra, Vito 445  
 Volterra integral equation, 445

## W

Wave equation, 630–649  
 defined, 630  
 plucked string, 637–642  
 vibrating string, 630–637  
 assumptions, 630

formal solution, 632–637  
 Wave, traveling, 639  
 orthogonal with respect to, 587 331  
 Wronskian  
 of solutions of homogeneous linear systems of differential equations, 523  
 of solutions of homogeneous second differential equations, 199–201  
 of solutions of homogeneous linear higher order differential equations, 467–469